

NOTES:

- 1) ALL DIMENSIONS SHOWN ARE IN INCHES (CENTIMETERS).
- 2) RELIEF VALVE, TRIDICATOR & CONDENSATE TRAP ARE INCLUDED SEPARATELY IN SHIPMENT.
- 3) AERCO RESERVES THE RIGHT TO MODIFY BOILER DIMENSIONS WITHOUT PRIOR NOTICE
- 4) FOR 12" EXHAUST VENTING, CONSULT YOUR PREFERRED VENTING MANUFACTURER FOR VENTING ADAPTER.

MATERIALS OF CONSTRUCTION				
PRESSURE VESSEL	SHELL OUTER-1/4" C.S. SA-516 GR.70 OR SA-53 GR.B SHELL INNER-1/4" STAINLESS STEEL, SA-240, 439SS HEAD-1" C.S. SA-516 GR.70 OR SA-53 GR.B EXPANSION JOINT-1/4" STAINLESS STEEL, SA-240, 439SS			
HEAT EXCHANGER	UPPER TUBESHEET- 1/4" STAINLESS STEEL, SA-240, 439SS LOWER TUBESHEET- 1/4" STAINLESS STEEL, SA-240, 439SS TUBES- STAINLESS STEEL, 5/8" O.D. X .049 WALL SA-249, 439SS SHELL- 1/4" C.S. SA-53 GRA OR B OR SA-516 GR.70			
INLET MANIFOLD	PIPE- 1/4" ST. STL. ASTM A312, 304SS ELBOW- 1/4" ST. STL. ASTM A403, 304SS MANIFOLD- 1/4" C.S. SA-53 GRA OR B OR SA-516 GR.70			
HEAT EXCHANGERS & COMBUSTION CHAMBER DESIGN STANDARDS				
MAX. WORKING PRESS. (PSIG)	MAXIMUM TEMP. (°F)	TEST PRESS. (PSIG)	HT'G SURFACE SQ. FT.	MIN. RELIEF VA. CAPACITY MBH
80	210	120	334	5000
150	210	225	334	
80	210	120	334	6000
150	210	225	334	
ASME B & PV CODE: SECTION IV STAMP H				

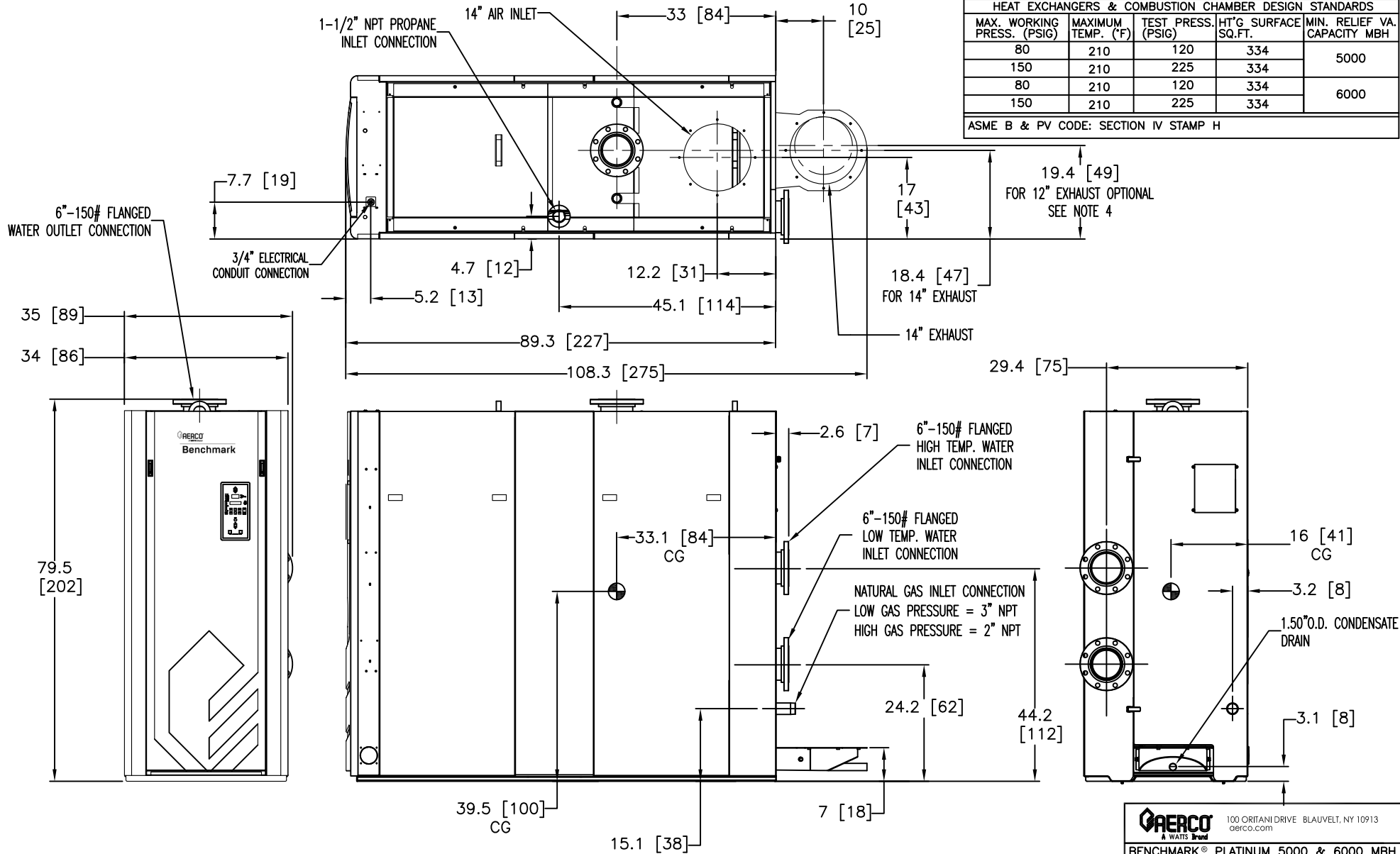

AERCO
A WATTS Brand

100 ORITANI DRIVE BLAUVELT, NY 10913
aerco.com

BENCHMARK® PLATINUM 5000 & 6000 MBH
NATURAL GAS, PROPANE, DUAL FUEL &
V.P.S. BOILER DUAL INLET
DIMENSIONAL DRAWING

DWN. BY	K.S.	DATE	022718	AP-A-1047	REV. C
SCALE		SIZE	A		
CHKD.		APPD.			
REV. DATE	K.S.		121520		