

FAQ

Stratified and Accumulator Storage

Proper piping of storage tanks is essential to maintain system temperatures. Frequently, improper plumbing can lead to cold slugs being delivered to fixtures and increase the opportunity for a storage tank to become a comfortable habitat for bacterial growth. Correct installation, operation and regular maintenance will mitigate that risk. The majority of today's systems will use either the Stratified or Accumulator storage method.

Stratified Storage Operation

Principal

Energy is stored in a stratified storage tank on a constant temperature-variable volume (of hot water) basis, i.e., the system depends on an absolute minimum of mixing of cold water and hot water in the tank. The discharge to the system is taken from the top of the tank and/or the heater. The supply of hot water in the upper portion of the tank is replenished at a constant rate by the heater operating at its maximum capacity. Tank storage must be large enough to accommodate the cumulative surge flows that occur in the maximum usage period.

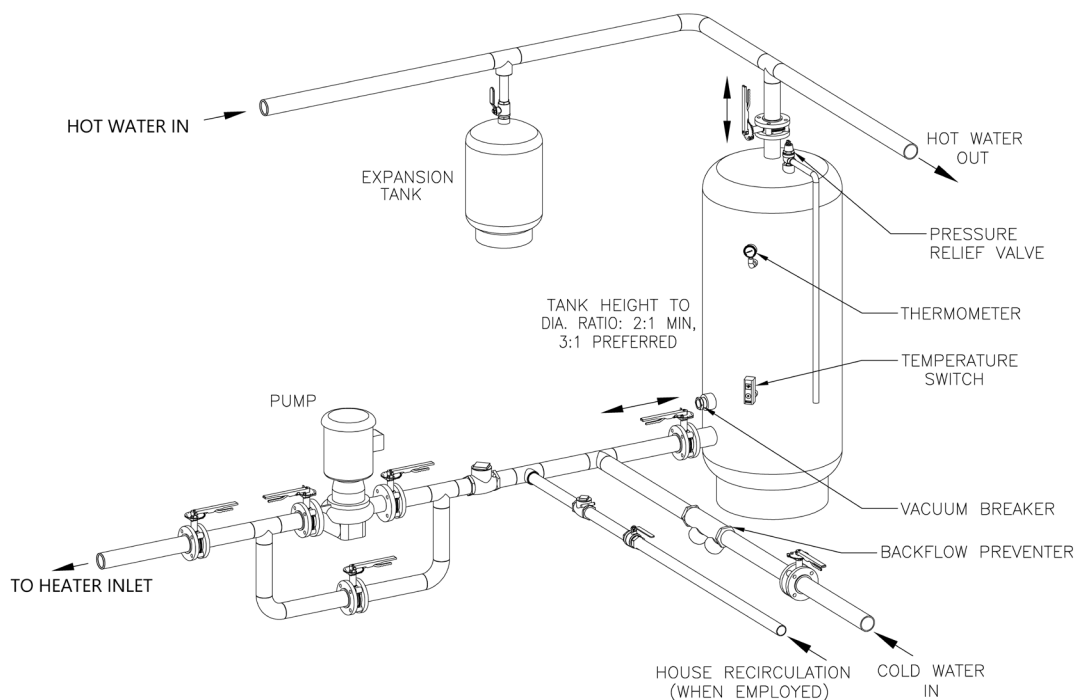

Figure 1: Stratified Storage Tank Piping Diagram

Sequence

Cold water enters the piping manifold at the side of the bottom inlet of the storage tank and hot water is drawn from the top of the tank. Both tank connections must be sized for maximum instantaneous demand calculated for the system demand. A dispersion tube may be included to create a boundary layer separating the cooler water at the lower section of the tank. Water is drawn by the system circulator from the bottom of the tank at

a constant rate equal to the maximum instantaneous capacity of the heater. The circulator is chosen with an adequate total discharge head (usually about 20 ft) to overcome piping and heater resistance. The balancing valve is set to maintain the desired flow rate. The water entering the heater is the coldest water in the system. It is heated in a single pass to the set point operating temperature and returned to the top inlet of the storage tank.

When the system recirculation is provided, it enters the bottom of the heater and passes through it to the top of the storage tank. Maximum stratification between hot and cold water is maintained in the storage tank by a vertical design with a side inlet cold water connection. When there is no demand on the system, cold water from the bottom is continuously heated and pumped to the top of the tank, and the boundary layer between hot and cold water falls. When the demand of the system exceeds the circulation rate, the hot water is drawn from the top of the tank, cold water enters the bottom, and the boundary in the storage tank rises.

The expansion tank in the system is required when insufficient expansion capacity is provided elsewhere. The total expansion capacity required is equal to the expansion of the water in the storage tank when it is heated through the full design temperature rise of the heater. If the local codes permit elimination of the check valve in the cold water supply, it is recommended, but not required.

Accumulator Storage Operation

Principal

Energy stored in the accumulator on a constant volume variable temperature basis, i.e., the system depends on the mixing of cold and hot water in the accumulator. The discharge from the system is taken from the outlet of the heater and not from the accumulator. With this arrangement, the heater acts as a pre-heater during periods of no or low demand and a booster heater during periods of high demand. The tank serves as a battery, storing energy to meet the next surge flow demand, while the recirculating pump acts as a governor for the heat input rate.

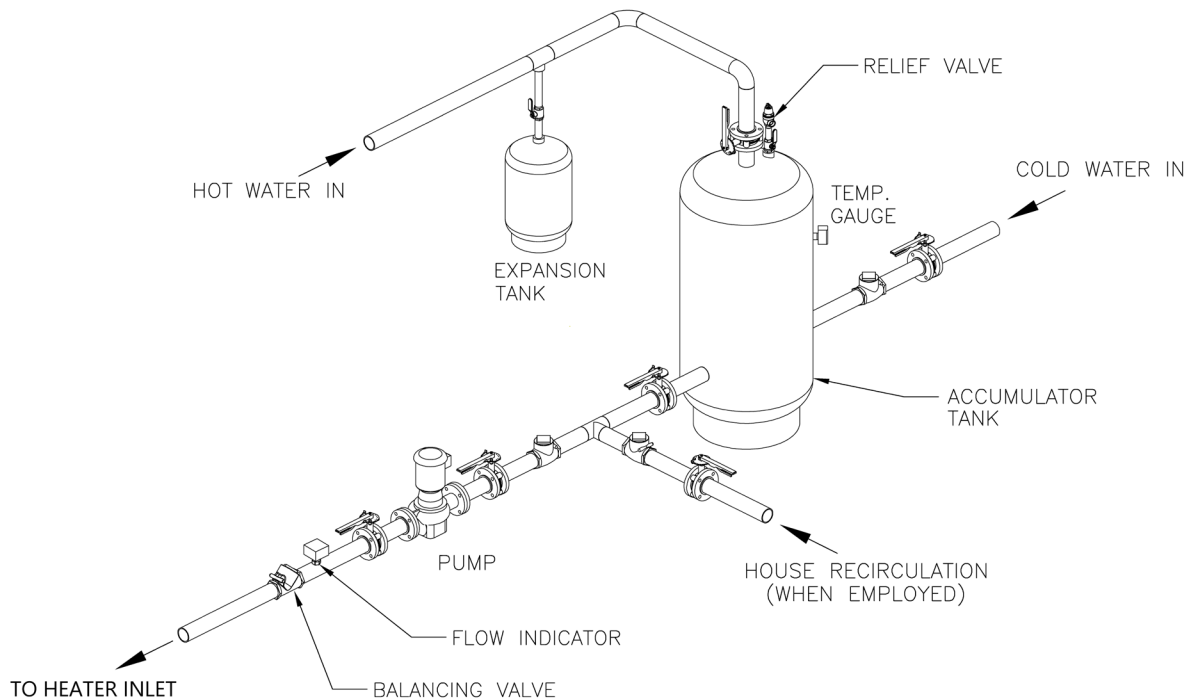

Figure 2: Accumulator Storage Tank Piping Diagram

Sequence

Cold water enters the lower inlet of the accumulator. Preheated water is drawn from the accumulator and through the AERCO heater where it is heated to the set temperature, before delivery to end uses.

When there is no demand, water from the top of the accumulator is passes through the heater and back to the bottom of the accumulator at a high flow rate. The circulator is selected to turn over the accumulator in approximately three minutes and with sufficient total discharge head (usually about 20 ft) to overcome the resistance of the piping and heater. The circulator flow rate is set by adjusting the balancing valve until the desired rate is being maintained and the pump is operating at the correct point on its curve.

If there is cold water in the bottom of the accumulator, the heater water mixes with the cold water to produce a relatively uniform temperature throughout. When a demand is placed on the system, the water from the top of the accumulator passes through the heater, bringing its temperature to the set point before flowing to the point of use. The increased total flow causes an increase in the pressure drop across the balancing valve and heater, causing a reduced recirculation rate and allowing more heat to be transferred to the water to the machines.

System recirculation, when provided, is fed to the discharge of the system circulator and into the accumulator.

An expansion tank in the system is required when insufficient expansion capacity is provided elsewhere and recommended regardless. The total expansion capacity required is equal to the expansion of the water in the accumulator when heated through the full design temperature rise of the heater. If the local codes permit elimination of the check valve in the cold water supply, it is recommended but not required.



Heating and Hot Water Solutions

AERCO International, Inc. • 100 Oritani Drive • Blauvelt, NY 10913
USA: T: (845) 580-8000 • Toll Free: (800) 526-0288 • AERCO.com

© 2020 AERCO