

Installation, Operation & Maintenance Manual

SmartPlate Domestic Hot Water Heaters

Single Wall Heater Models:

SP23, SP33, SP45, SP69, SP150

Double Wall Heater Models:

SPDW23, SPDW32, SPDW42, SPDW61,
SPDW113

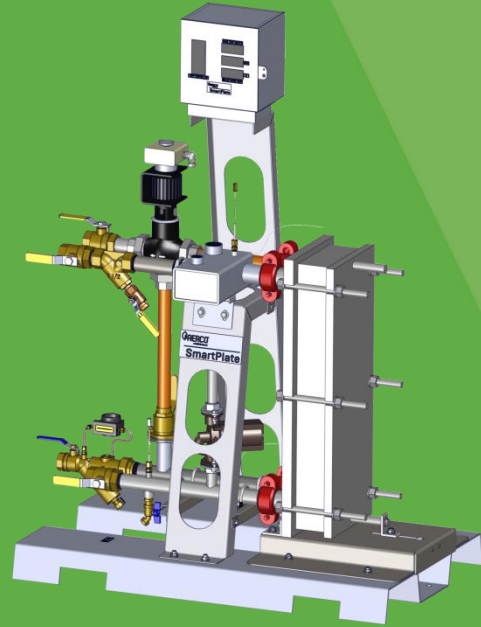
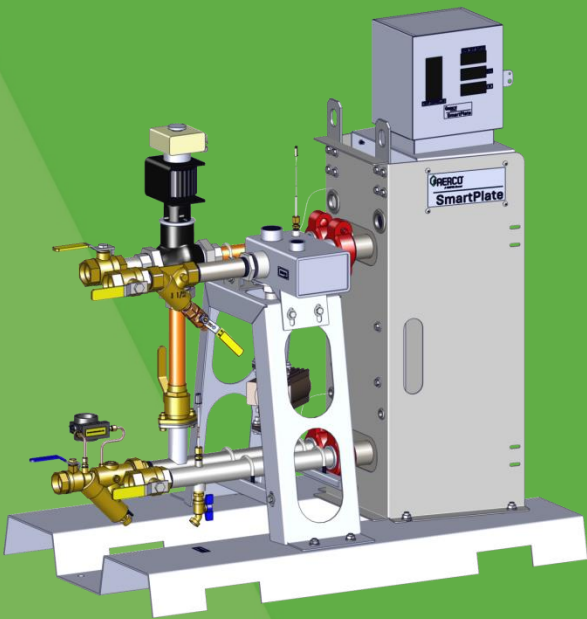

Disclaimer

The information contained in this document is subject to change without notice from AERCO International, Inc. AERCO makes no warranty of any kind with respect to this material, including, but not limited to, implied warranties of merchantability and fitness for a particular application. Some states do not allow the exclusion or limitation of incidental or consequential damages, so the above limitation may not apply. AERCO International is not liable for errors appearing in this document, not for incidental or consequential damages occurring in connection with the furnishing, performance, or use of these materials.

Heating and Hot Water Solutions

AERCO International, Inc. • 100 Oritani Drive • Blauvelt, NY 10913
USA: T: (845) 580-8000 • Toll Free: (800) 526-0288 • AERCO.com
Technical Support • (800) 526-0288 • Mon-Fri, 8 am - 5 pm EST
© 2024 AERCO

Table Of Contents

CHAPTER 1. GENERAL INFORMATION	5
1.1 Introduction	5
1.2 Electronic Control System/Smartplate (Ecs/Sp)	6
1.2.1 Control Box Assembly	7
1.2.2 Feed-Forward Temperature Sensors	8
1.2.3 Outlet Temperature Sensors	8
1.2.4 Boiler Water Inlet/Outlet Temperature Sensors	8
1.3 Smartplate Piping Assemblies	9
1.4 Electronic Control Valve, Mxg-461	9
CHAPTER 2. INSTALLATION	11
2.1 Introduction	11
2.2 Receiving And Unpacking Smartplate	11
2.3 Site Selection And Preparation.....	12
2.3.1 Installation Clearances	12
2.3.2 Setting The Unit	13
2.3.3 Repositioning Ecs/Sp Control Box.....	14
2.4 Heating Fluid and Domestic Hot Water (DHW) Piping	15
2.5 Smartplate Electrical Wiring Connections.....	16
2.6 Additional Component Installation.....	21
CHAPTER 3. FUNCTIONAL DESCRIPTION	23
3.1 Introduction	23
3.2 Mechanical Overview	23
3.3 Electronic Control Overview	23
3.4 Over-Temperature Control and Safety Features.....	24
CHAPTER 4. ADJUSTMENT	27
4.1 Introduction	27
4.2 Smartplate 3-Way Control Valve, Mxg-461 Adjustment	27
4.2.1 Control Valve Calibration And Status Indications	27
4.2.2 Manual Control Of 3-Way Valve – Removable Handwheel To Hamper Tampering.....	30
4.2.3 Setpoint Temperature Adjustment.....	31
4.2.4 Over-Temperature Alarm Limit Adjustment	34
CHAPTER 5. OPERATION	37
5.1 Introduction	37
5.2 Pre-Operational Checks & Procedures	37
5.3 Initial Start-Up	38
5.4 Checking Mixed Inlet Temperature	39
5.5 Shutting Down the System.....	39
CHAPTER 6. SCHEDULED MAINTENANCE	41
6.1 Introduction	41
6.2 Boiler Water Differential Pressure Gauge Check.....	42
6.3 Plate Pack Leakage Checks (Double-Wall Models Only)	43
6.4 Over-Temp Switch Check	43
6.5 Strainer Inspection And Cleaning	44
6.6 Control Valve Operational Check	44

CONTENTS

6.7 Temperature Sensor Checks	44
6.8 Recirculation Pump Check.....	45
6.9 Periodic Cleaning of Heat Exchanger	46
CHAPTER 7. TROUBLESHOOTING	47
7.1 Introduction	47
7.2 Troubleshooting Procedures.....	47
CHAPTER 8. CORRECTIVE MAINTENANCE.....	57
8.1 Smartplate Single-Wall Heat Exchanger Models.....	57
8.1.1 Single Wall Heat Exchanger Maintenance.....	57
8.1.2 Heat Exchanger Cleaning & De-Scaling	57
8.1.3 Single-Wall Heat Exchanger Replacement	60
8.2 Smartplate Double-Wall Heat Exchanger Maintenance	63
8.2.1 Double-Wall Heat Exchanger Cleaning.....	63
8.2.1.1 Heat Exchanger Cleaning and De-Scaling (In-Place Method).....	64
8.2.1.2 Heat Exchanger Cleaning By Disassembly.....	64
8.2.2 Double-Wall Heat Exchanger Opening And Closing.....	66
8.2.2.1 Opening Heat Exchanger	66
8.2.2.2 REMOVAL AND INSERTION OF PLATES.....	69
8.2.3 Closing Heat Exchanger	70
8.2.4 Double-Wall Heat Exchanger Gasket Replacement.....	73
8.2.4.1 Replacing Gaskets on Channel Plates.....	73
8.2.4.2 Replacing Gaskets on End Plate (First Plate Against Frame Plate).....	74
8.2.5 Double-Wall Heat Exchanger Replacement.....	75
8.3 Smartplate Wetted Components - All Models	79
8.3.1 Control Valve Electronic Module Replacement And Valve Removal	79
8.3.1.1 Electronics Module Replacement	79
8.3.1.2 Control Valve Replacement	80
8.3.2 Recirculation Pump Replacement.....	82
8.3.3 Strainers	84
8.4 Smartplate Electronic Control System (Ecs/Sp).....	86
8.4.1 Ecs/Sp Control Box Assembly And Components.....	86
8.4.2 Control Box Assembly Replacement	86
8.4.3 Temperature Controller Replacement.....	87
8.4.4 Over-Temperature Switch And Temperature Indicators	87
8.4.5 24 Vac Step-Down Transformer Replacement	89
APPENDIX A – Eurotherm 3508 Controller Operation.....	95
APPENDIX B - Modbus Control and Communication	101
APPENDIX C – ECS/SP WIRING DIAGRAM & TERMINAL BLOCK CONNECTIONS	111
APPENDIX D – SMART PLATE PIPING DRAWINGS	113
APPENDIX E – DIMENSIONAL DRAWINGS	125
APPENDIX F – PART LISTS.....	127
APPENDIX G – RECOMMENDED SPARE PARTS	137

CHAPTER 1. GENERAL INFORMATION

1.1 Introduction

This manual provides detailed coverage for the AERCO SmartPlate line of Water-to-Water Heaters. Each SmartPlate Water Heater model is equipped with AERCO’s Electronic Control System (ECS), specifically designed for SmartPlate (ECS/SP), and an Electronic Control Valve, MXG-461. This Control System and Valve combination is used with all SmartPlate models and sizes.

The following SmartPlate Single-Wall and Double-Wall Heat Exchanger Water Heater models are available:

Type	SmartPlate Models	Pressure Options *	Power Options**
Single Wall	SP23, SP33 SP45, SP69, SP150	150 PSI	120V 60 Hz 220V 50 Hz 220V 60 Hz
		200 PSI	
Double Wall	SPDW23, SPDW32, SPDW42, SPDW61, SPDW113	150 PSI	
		200 PSI	

* Appropriate add-on kits differentiate overall product for given DHW side operating pressure.

** Internal power wiring and recirculation pump differentiates the power option.

Figure 1-1 shows a typical SmartPlate Water Heater with a single-wall heat exchanger. Piping assembly components are similar for double-wall models. The remaining sections in this chapter provide descriptions of the units, assemblies and sub-assemblies included with the SmartPlate models.

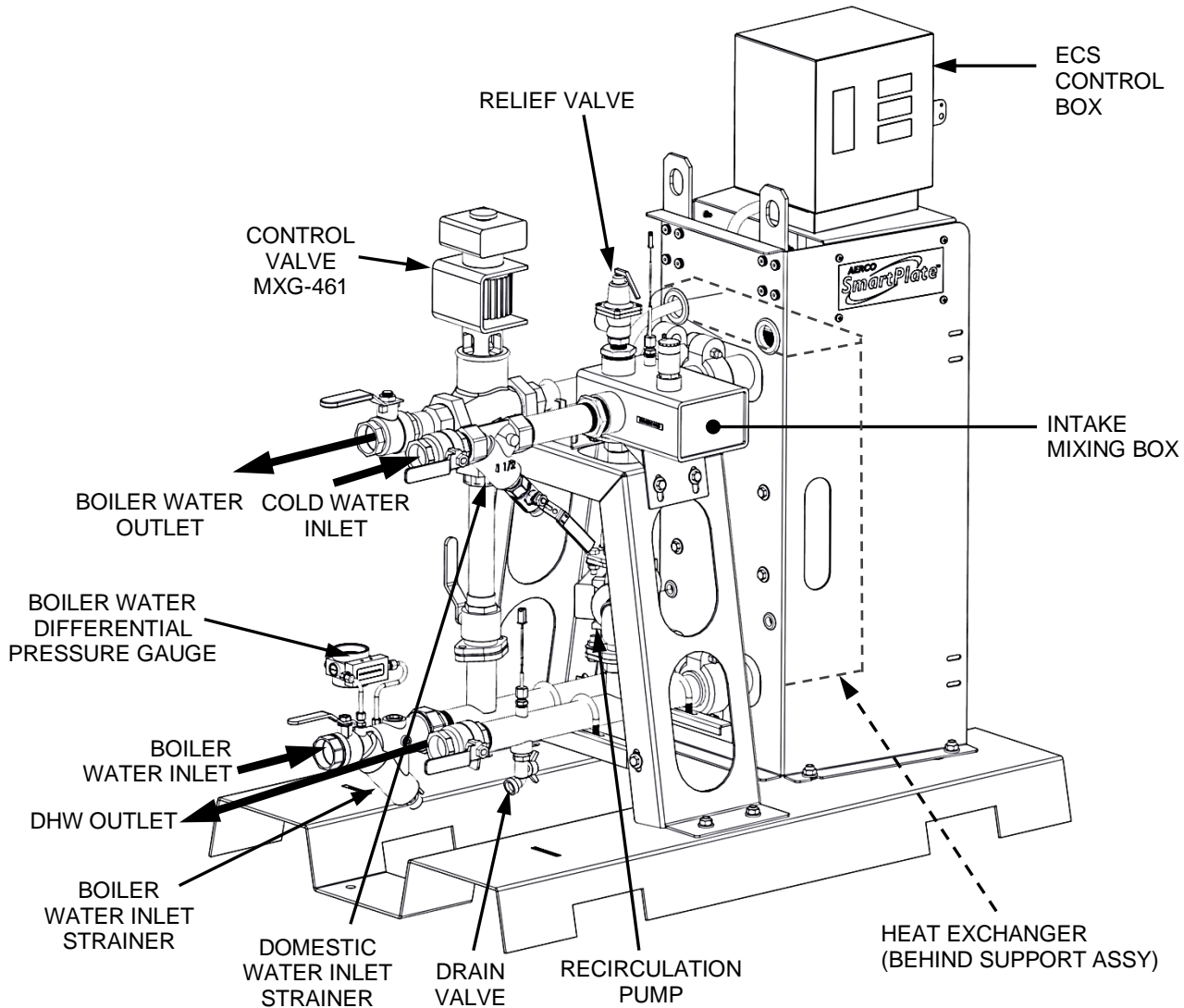

Figure 1-1. Typical SmartPlate Packaged Water Heater – Single Wall Shown

1.2 Electronic Control System/Smartplate (Ecs/Sp)

Identical Electronic Control Systems are used on all SmartPlate models. This system, commonly referred to as the ECS/SP, contains a Control Box Assembly which includes all of the electronic circuitry for the ECS/SP. In addition, the ECS/SP includes several sensors and safety devices which provide temperature and flow control information to the Control Box circuitry. The Control Box and the additional devices included in the ECS are shown in Figure 1-2. The additional devices included in the ECS/SP include:

- Feed-Forward (Mixed Water) Temperature Sensor (Type J Thermocouple)
- DHW Outlet Dual Temperature Sensors (Type J Thermocouples)
- Boiler Water Inlet/Outlet Temperature Sensors (Type J Thermocouples)
- Over-Temperature Alarm (With Safety Shutdown)

If desired, the ECS/SP can be ordered with a Modbus communication option. This option permits the ECS/SP to be externally controlled by an Energy Management System (EMS), Building Automation System (BAS), or a computer supplied by other manufacturers.

The ECS/SP assemblies and components are described in the following subordinate sections.

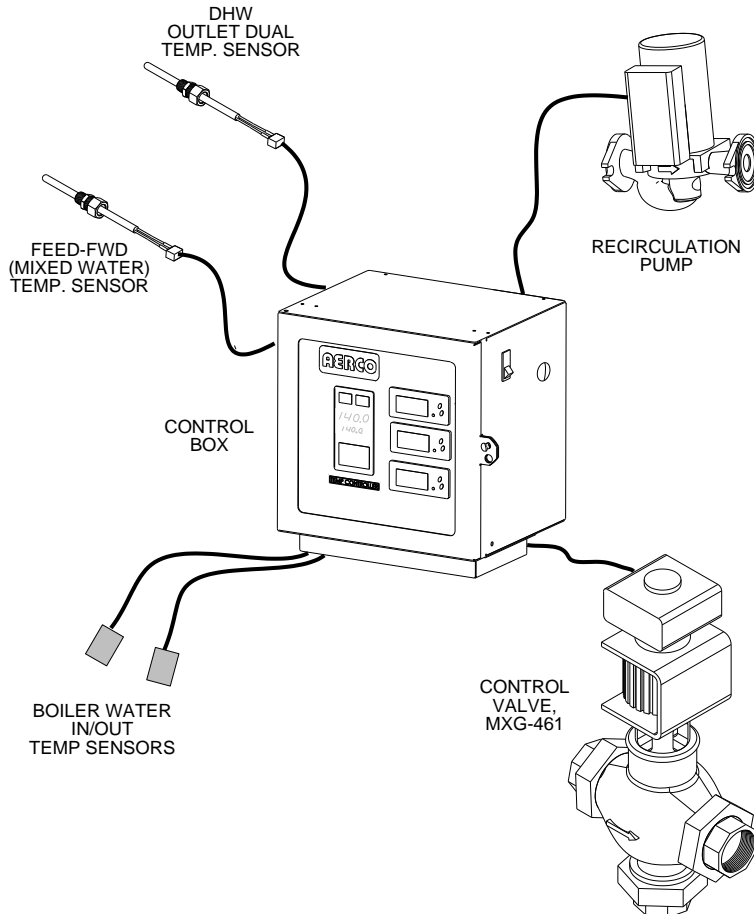

Figure 1-2. Electronic Control System/SmartPlate (ECS/SP)

1.2.1 Control Box Assembly

The front panel on the Control Box assembly contains all of the display devices for the ECS/SP. These include the Temperature Controller, an Over-Temperature Indicator/Switch and Boiler Water In/Out Temperature Indicators.

The Temperature Controller is the “brain” of the ECS/SP, which processes data received from the temperature sensors. Using feed forward and PID (Proportional Integral Derivative) algorithms, the Temperature Controller provides a 0 to 10 VDC control signal to the Control Valve Actuator, which precisely modulates the Control Valve for optimum DHW outlet temperature control. The upper display on the front panel of the Temperature Controller displays the current DHW outlet temperature. The lower display continuously displays the DHW setpoint temperature currently stored in the Temperature Controller.

The Over-Temperature indicator/switch included in the Control Box constantly monitors and displays the unit's outlet temperature to ensure it does not exceed the preset high temperature limit. The over-temperature limit is factory-set 20°F above the unit's setpoint temperature specified on the sales order. If an over-temperature condition occurs, this device sounds an audible alarm and cuts off power to the Control Valve Actuator thereby closing the Control Valve and shutting off the boiler water flow to the unit.

The Boiler Water inlet and outlet temperatures are sensed on the surface of the inlet/outlet pipes and are provided for informational and troubleshooting purposes only. They are not used for temperature control but they do have alarm limits available for customer settings, if desired.

The Control Box components are housed in a steel enclosure with a hinged front door. This door contains a clear polycarbonate window which permits maintenance personnel to view the controls and displays of the Temperature Controller, and other display devices mounted on a recessed panel behind the door. All sensor and control signal connections are made via cable connections at the bottom of the Control Box. External AC power (120 VAC, 60 Hz, 220 VAC 50 Hz or 220V, 60 Hz) is supplied via the cutout on the bottom of the Control Box. If desired, the Control Box can be easily repositioned in 90° increments from its default position shown in Figure 1-1. Refer to Chapter 2, section 2.3.3 for details.

1.2.2 Feed-Forward Temperature Sensors

The Feed-Forward Temperature Sensor (Type J thermocouple) is installed in the cold water inlet mixing box on the unit. The Temperature Sensor monitors a portion of the inlet flow to the unit and provides a feed-forward signal to the Temperature Controller which is proportional to the change in flow through the unit.

1.2.3 Outlet Temperature Sensors

The Control System includes a Dual Temperature Sensor which is installed in the hot water outlet of the unit. This sensor contains two identical Type J thermocouples. The first thermocouple connects directly to the Temperature Controller to provide feedback PID control for the outlet water temperature. The second thermocouple connects to the Over-Temperature Indicator/Switch in the Control Box.

1.2.4 Boiler Water Inlet/Outlet Temperature Sensors

Two additional Temperature Sensors (Type J thermocouples) are provided with the Control System. One Temperature Sensor is attached to the boiler water inlet and the other is attached to the boiler water outlet of the unit. These two Sensors are connected to two identical Temperature Display Indicators in the Control Box to provide real-time indications of the inlet and outlet boiler water temperatures. These Temperature Indicators are physically identical to the Over-Temperature Indicator/Switch, but are used as "Indicator-Only" devices and do not provide any switching functions. However, the Boiler Water Inlet Indicator will signal an alarm condition if the boiler water temperature exceeds 250°F.

1.3 Smartplate Piping Assemblies

The diameter of the piping assemblies furnished with the water heater will depend on the size of the heat exchanger installed in the SmartPlate model ordered. Smaller sized models utilize 1.5” piping assemblies, while the larger sizes utilize 2” piping assemblies. Refer to Table 1-1 below for the size of the piping assemblies used in each Single-Wall and Double-Wall SmartPlate model.

TABLE 1-1. SmartPlate Model Piping Assemblies		
Type	SmartPlate Model	Piping Assembly Diameter
Single-Wall	SP23, SP33	1.5”
	SP45, SP69, SP150	2”
Double-Wall	SPDW23, SPDW32	1.5”
	SPDW42, SPDW61, SPDW113	2”

In addition to the heat exchanger and piping components, each SmartPlate Piping Assembly contains a number of other important components and assemblies. The items include:

- Mixing box
- Recirculation Pump, (Continuously ON)
- Isolation & Drain Valves
- Strainers (Boiler Water & DHW Sides)
- Blow-down Valves
- Relief Valve
- Air Vent Valve

Figure 1-3 illustrates the locations of the above-mentioned items for a single-wall heat exchanger. Piping components are similar for double-wall models.

1.4 Electronic Control Valve, Mxg-461

The 3-Way Electronic Control Valve (Siemens MXG-461) is powered by 24 VAC which is received from the ECS/SP Control Box. The Temperature Controller in the Control Box supplies a 0 – 10 VDC control signal to precisely modulate the 3-Way Valve to accurately control the temperature of the DHW output to the desired setpoint. The Control Valve is shown in Figure 1-4. The connection unions have flat face gaskets that provide the fluid seal.

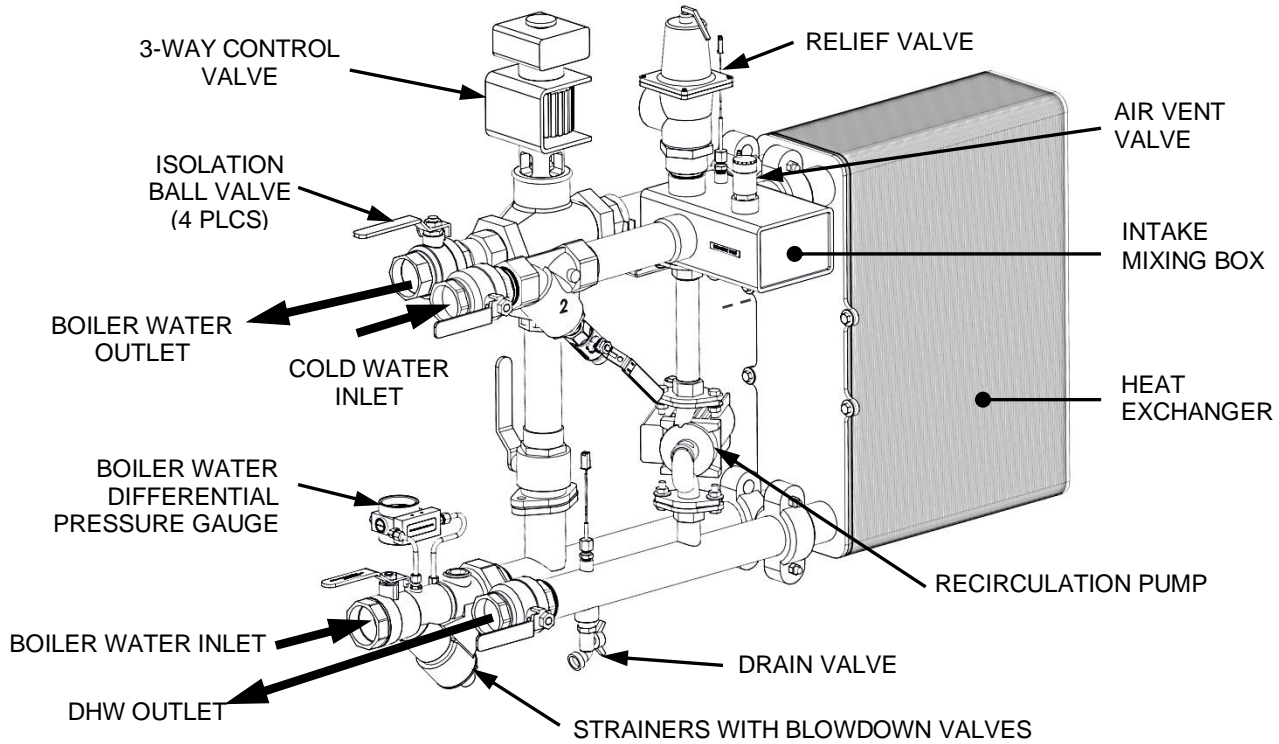

Figure 1-3. Typical SmartPlate Piping Assembly – 2” Piping Shown

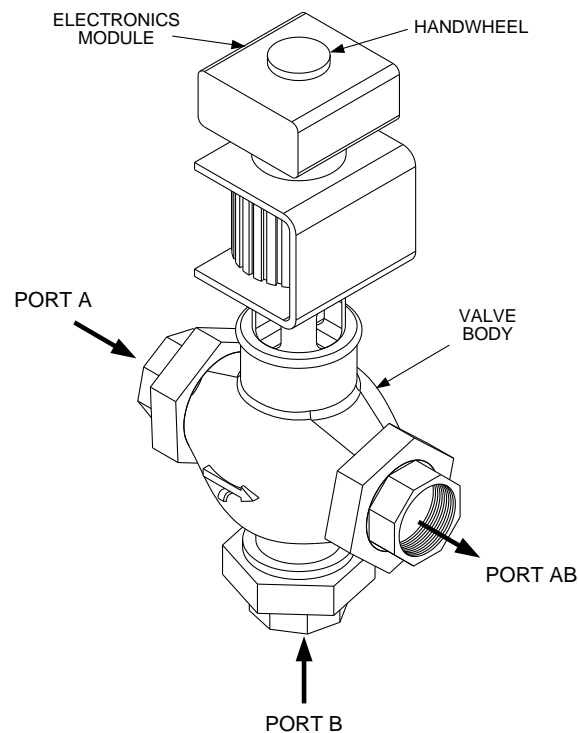

Figure 1-4. Electronic Control Valve

CHAPTER 2. INSTALLATION

2.1 Introduction

All SmartPlate Water Heaters are shipped fully assembled and ready for installation. Therefore, installation will consist of the following tasks:

- Unpack the SmartPlate Water Heater from its shipping container.
- Position and secure the unit at the site.
- Install the Relief Valve and Air Vent Valve on the mixing box.
- On units installed in New York City, install a second Relief Valve on the boiler water intake piping.
- Connect the hot boiler water piping to the unit.
- Connect the domestic hot water (DHW) piping to the unit.
- Connect external AC power to the ECS/SP Control Box.
- If required, connect Modbus control wiring to the Temperature Controller in the ECS/SP Control Box.

2.2 Receiving And Unpacking Smartplate

Each SmartPlate Water Heater is shipped as a single crated unit. The packaged shipping weight will vary from 380 to approximately 1100 pounds depending on the model ordered. The unit must be moved with the proper equipment (forklift, pallet jack, etc.) to avoid possible injury to personnel or damage to the shipping container or unit. The shipping carton should be inspected for damage incurred during transit prior to signing the bill of lading.

NOTE: AERCO is not responsible for lost or damaged freight. The freight carrier must be notified immediately of any damage detected.

Unpack the SmartPlate Water Heater from its shipping container taking care not to damage the unit when cutting away the packaging material.

Remove the package containing the Relief Valve and Air Vent Valves. This package may also contain an additional Relief Valve. See section 2.6 for a complete list of parts and installation instructions.

Remove the bolts securing the unit to its shipping skid. Perform a complete visual inspection of the unit to ensure there is no evidence of damage.

2.3 Site Selection And Preparation

Ensure that the site selected for installation of the SmartPlate Water Heater includes the following:

- Access to AC input power at **120 VAC/60 Hz, 220 VAC/50 Hz** or **220 VAC 60 Hz**, single phase.
- Close proximity to the boiler to be used as the heating fluid (hot water) source
- If applicable; access to Modbus Network wiring within the prescribed wire lengths (see section 2.5).

2.3.1 Installation Clearances

The heater must be installed with the prescribed clearances for service as shown in Figure 2-1. The minimum clearance dimensions recommended by AERCO are listed below. However, if local building codes require additional clearances, these codes shall supersede AERCO’s recommendations.

- Sides: 24 in. (61 cm)
- Front: 24 in. (61 cm)
- Rear: 24 in. (61 cm)
- Top: 12 in. (30.5 cm)

All water piping and electrical conduit must be arranged so that it does not interfere with the removal of any Water Heater assemblies/parts or inhibit service or maintenance of the unit.

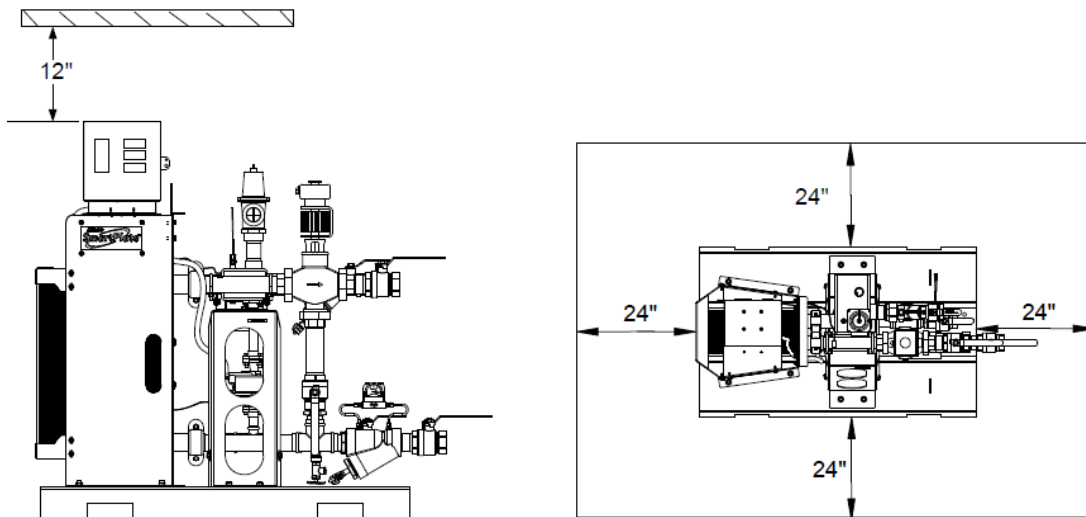

Figure 2-1. SmartPlate Water Heater Clearances

CAUTION!

While packaged in the shipping container, the heater must be move using a forklift or pallet jack. After unpacking, the heater should be lifted and moved using the lifting tabs (single-wall model), or frame cutouts (double-wall model) provided on the heater. Alternately, a forklift or pallet jack may be used to move the unit by inserting the tines through the cutouts in the heater base (Figure 2-1). Refer to the information in the following section.

2.3.2 Setting The Unit

SmartPlate Single-Wall models contain two lifting tabs at the top of the frame assembly (Figure 2-2 a). Use these tabs to lift and move the unit. Double-Wall models contain two round cutouts on the frame plate and two on the pressure plate of the heat exchanger (Figure 2-2 b). To lift and move the unit, use these cutouts, or wrap the lifting strap around the threaded bolts protruding from the heat exchanger (Figure 2-2 b).

In multiple unit installations, it is important to plan the position of each unit in advance. Sufficient space for piping connections and future service/maintenance requirements must also be taken into consideration. All piping must include ample provisions for expansion.

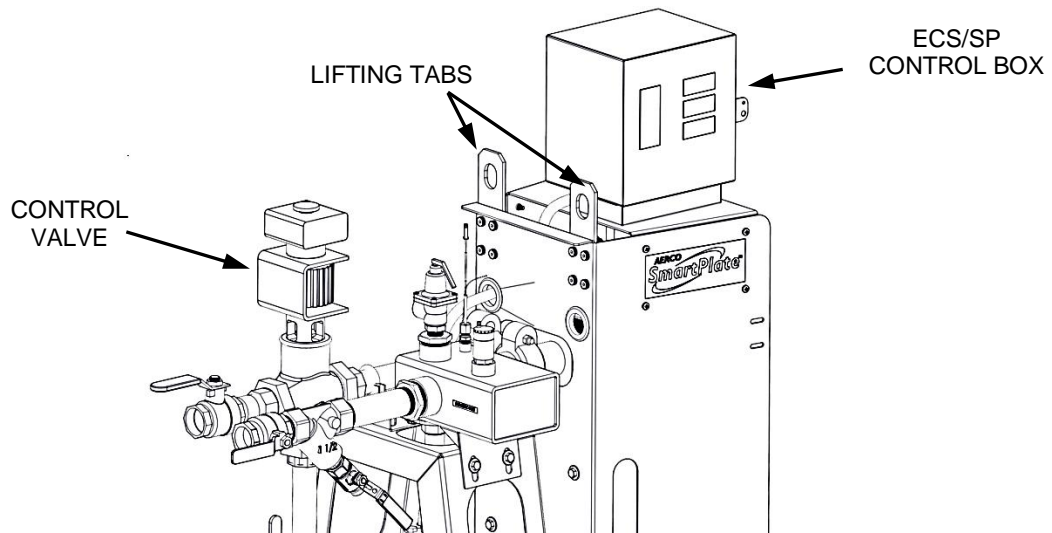

Figure 2-2 a. SmartPlate Lifting Provisions – Single-Wall Models

CAUTION!

For Single-Wall models, DO NOT attempt to reposition the ECS/SP Control Box with the panel displays facing the unit's Piping Assembly, as the location of the lifting tabs will prevent the Control Box door from opening fully (Figure 2-2 a).

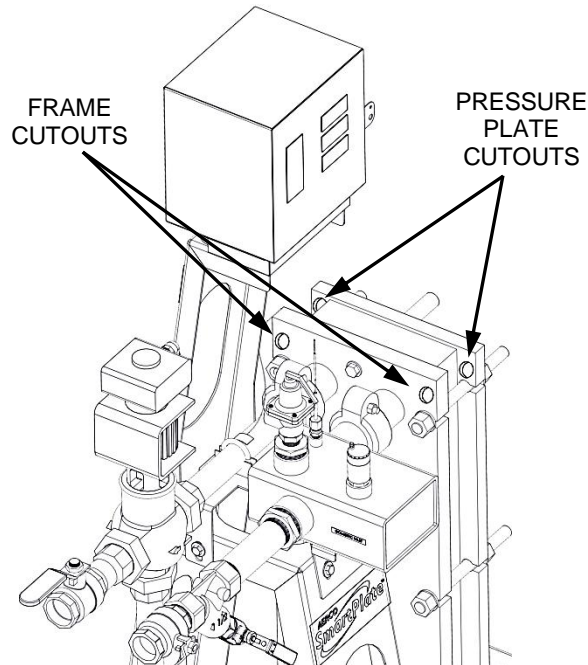

Figure 2-2 b. SmartPlate Lifting Provisions – Double-Wall Models

2.3.3 Repositioning Ecs/Sp Control Box

If required, the front panel displays of the ECS/SP Control Box can be repositioned from the default left-side of the unit (Figure 2-2) to either the right side or rear of the unit to optimize viewing of the panel displays. Repositioning of the Control Box is accomplished as follows:

REPOSITIONING ECS/SP CONTROL BOX Instructions

1. Power the unit off.
2. Disconnect external cables at their respective connections (Molex).
3. From the rear of the unit (Figure 2-3, below), remove the four Phillips head screws securing the base of the Control Box to the unit's frame assembly.
4. Position the Control Box to the desired orientation to provide easy viewing of the control panel displays.
5. Ensure that all power and control wiring are of sufficient length to prevent undue stress on the wiring connections. Reposition wiring harnesses as necessary.
6. Replace the four Phillips head screws removed in step 1.
7. Apply power if previously connected.
8. This completes the repositioning of the ECS/SP Control Box.

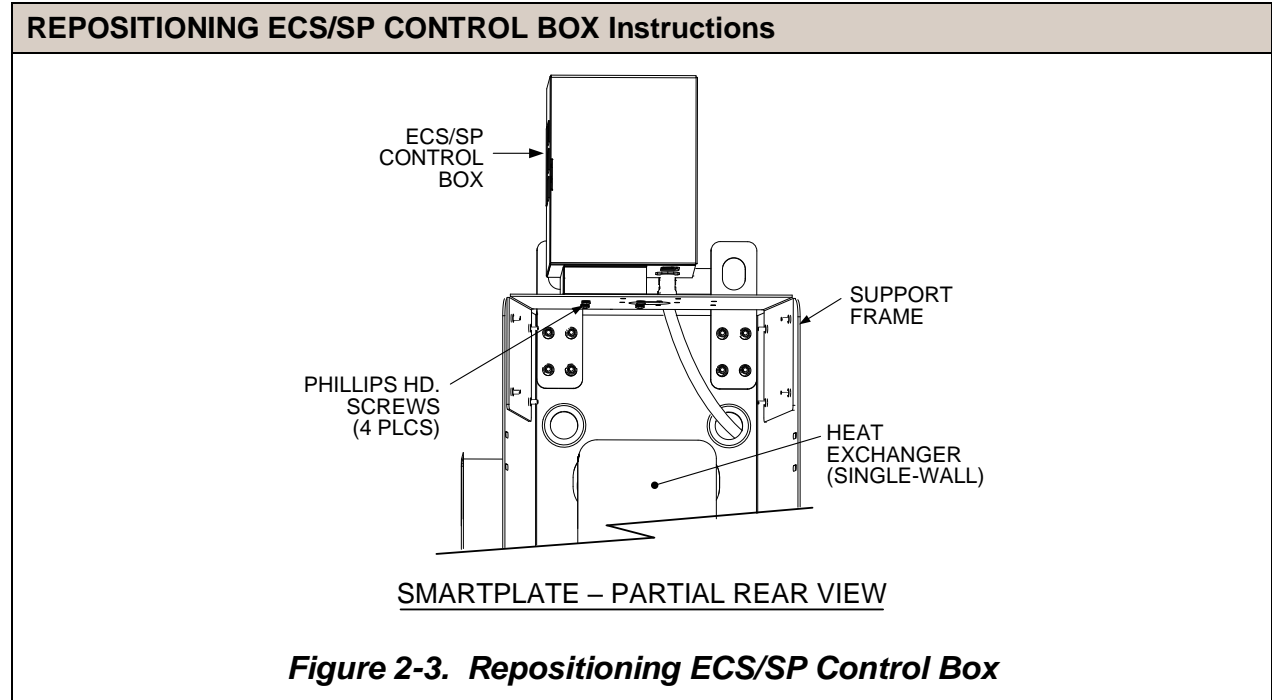

2.4 Heating Fluid and Domestic Hot Water (DHW) Piping

The diameter of the heating fluid (hot boiler water) and DHW piping will depend on the model number and size of the unit being installed. Refer to Table 2-1 for applicable piping sizes.

TABLE 2-1. Pipe Sizing Chart

Type	SmartPlate Water Heater Model	Pipe Diameter
Single-Wall	SP23, SP33	1.5 inches
	SP45, SP69, SP150	2.0 inches
Double-Wall	SPDW23, SPDW32	1.5 inches
	SPDW42, SPDW61, SPDW113	2.0 inches

CAUTION!

Two pipe wrenches MUST be used when installing boiler water and DHW piping unions to prevent pipe rotation and avoid leaks.

The locations and spacing for the heating fluid (hot boiler water) and DHW piping are provided in Dimensional Drawings AP-A-846 (Single-Wall) and AP-A-847 (Double-Wall), included in Appendix D of this document. In addition, sample piping diagrams are provided in Appendix C for single and multiple unit installations.

IMPORTANT!

When SmartPlate Water Heaters are shipped from the factory, all four isolation ball valves and the drain valve (Figure 1-3) are opened. Close all valves during installation. Do not open the valves until instructed to do so in Chapter 5 of this manual.

2.5 Smartplate Electrical Wiring Connections

The SmartPlate ECS/SP Control Box and all other ECS/SP components are installed on the unit prior to shipment from the factory. Therefore, electrical connections to the ECS/SP basically consist of connecting external AC power to the ECS/SP Control Box. The system can be powered by a single-phase AC voltage of 120 VAC, 60 Hz, 220 VAC, 50 Hz or 220 VAC 60 Hz. However, if the ECS/SP was ordered with the Modbus Communication option, several additional signal lead connections will need to be made inside the Control Box. These signal leads will permit the ECS/SP to be controlled by an external Energy Management System (EMS), Building Automation System (BAS), or Computer. Proceed as follows:

NOTE: Following installation, a lock (Not Supplied) can be installed on the front door of the Control Box, if desired, to prevent unauthorized access to ECS settings.

ELECTRICAL WIRING CONNECTIONS Instructions

1. Loosen the captive screw on the right-front portion of the Control Box (Figure 2-4) to open the hinged panel door.

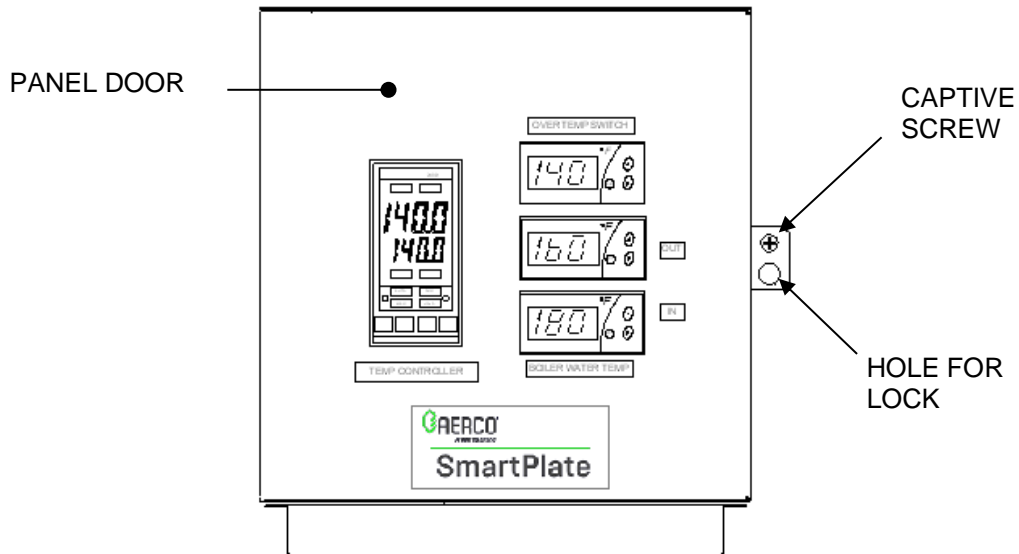

Figure 2-4. ECS/SP Control Box Front View

2. Open the door and loosen the captive screw at the top of the recessed panel (Figure 2-5).

ELECTRICAL WIRING CONNECTIONS Instructions

PANEL CAPTIVE SCREW

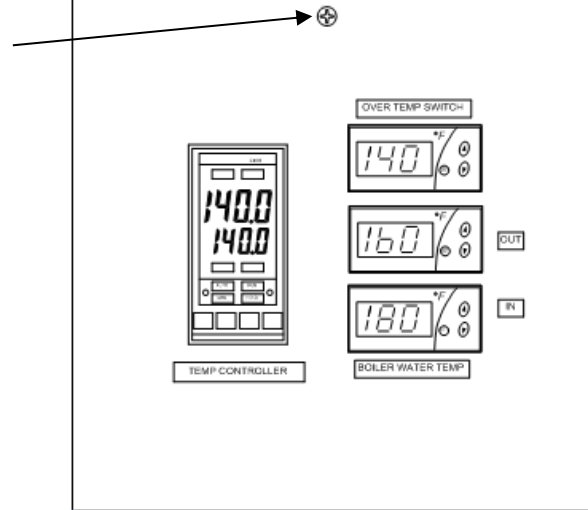
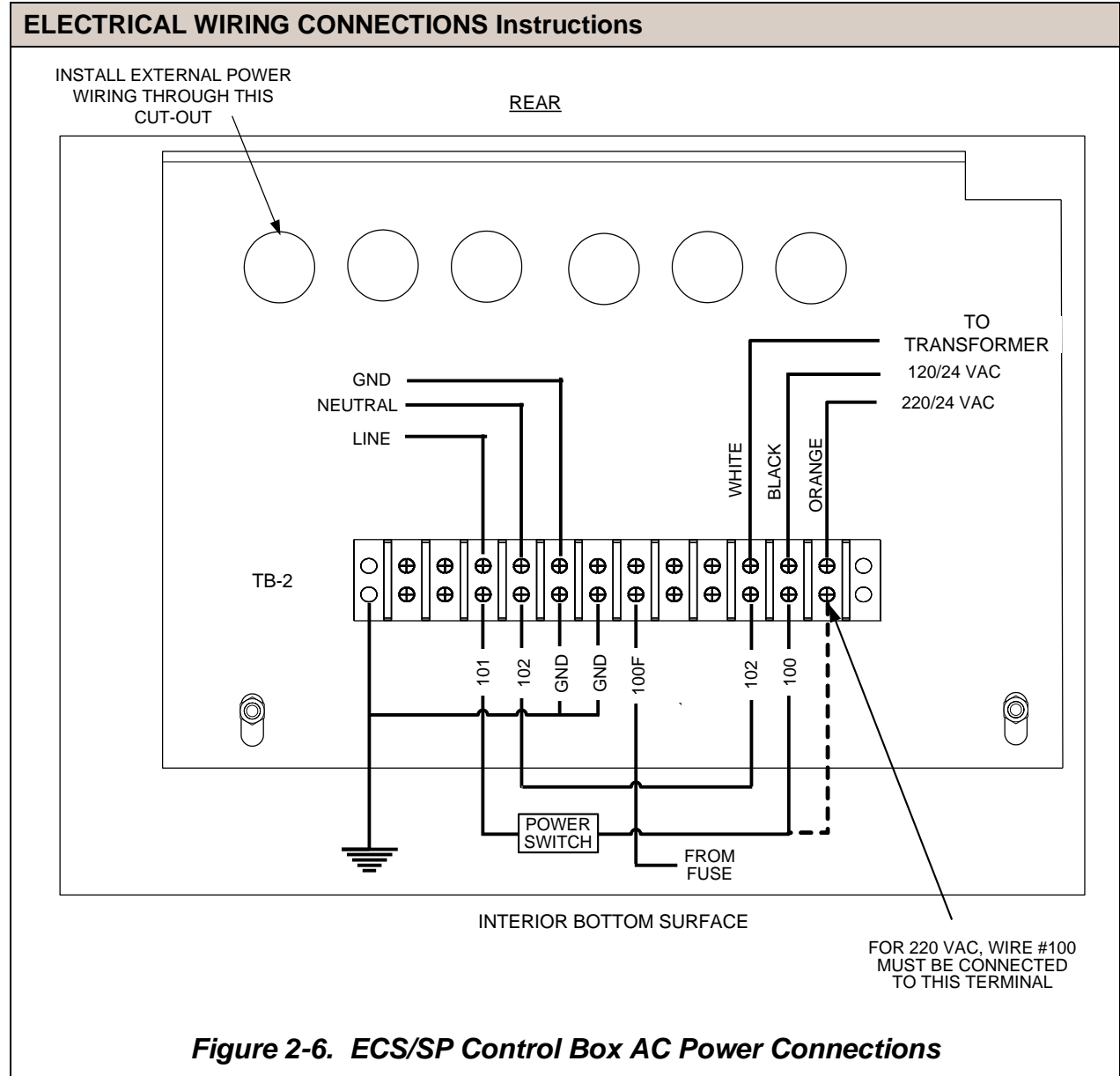

Figure 2-5. Recessed Panel Behind ECS/SP Control Box Door

- Swing down the recessed panel to access Terminal Block TB-2 on the bottom interior surface of the Control Box, shown in Figure 2-6.

NOTE: Use 14-18 AWG wire for AC power connections to SmartPlate ECS/SP Control Box.

- Feed the external 120/220 VAC power leads through the cutout labeled “POWER IN” on the bottom of the Control Box.
- Connect LINE, NEUTRAL and GROUND leads to the TB-2 terminals shown in Figure 2-6.
- Check the connection of wire #100 on the right side of TB-2 to ensure the power is routed to the proper connection for the 24 VAC transformer. If the incoming power is 120 VAC, wire #100 should be connected to the terminal with a black wire and the orange wire should have nothing connected to its terminal. Conversely, if the incoming power is 220 VAC, wire #100 should be connected to the terminal with the orange wire and the black wire left unconnected.



ELECTRICAL WIRING CONNECTIONS Instructions

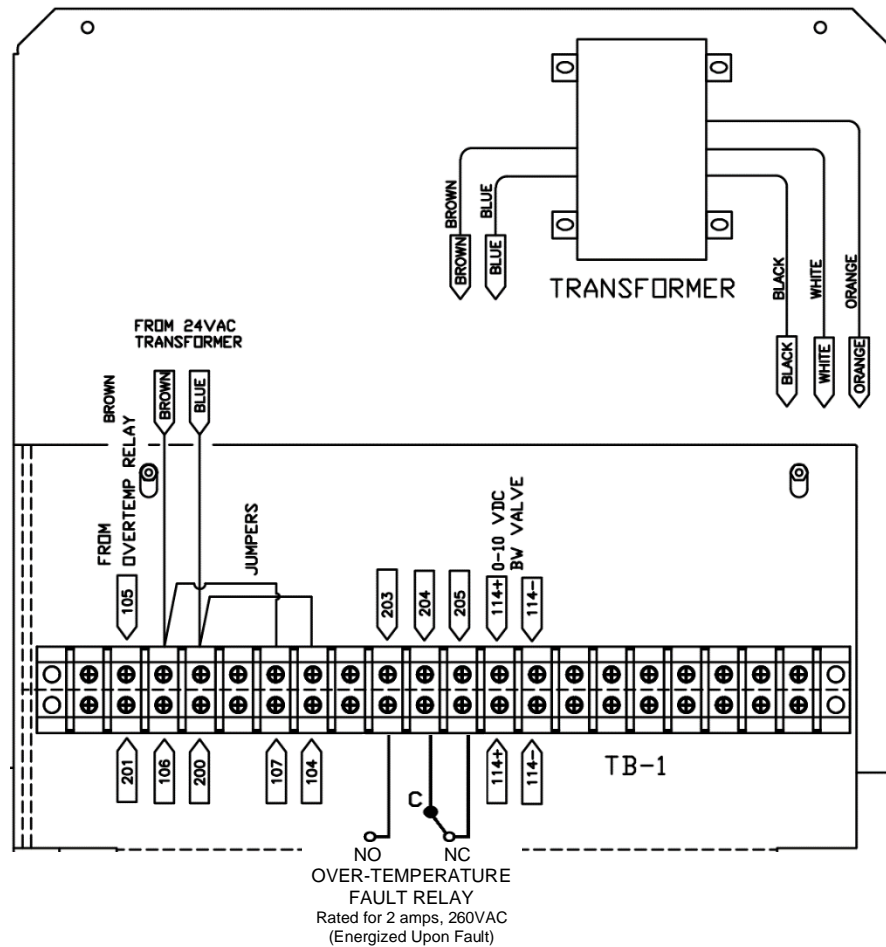

Figure 2-7: Remote Relay Option Kit (P/N 69018) Schematic

- If the ECS was ordered with the Modbus Communication Option, proceed to step 8. However, if this option is not included, no further steps are required. In that case, re-secure the hinged swing-down panel of the Control Box and close the front panel door.

NOTE: Step 8 applies ONLY to SmartPlate Control Systems that include a Temperature Controller (Eurotherm, model 2408) equipped with a Communications Board that allows connection to Modbus Networks. The required signal connections will depend on the ports available on the Energy Management System (EMS), Building Automation System (BAS), or Computer being used with the ECS/SP.

CAUTION!

DO NOT route Modbus communication wiring in the same conduit as power wiring. Attempting to do so may result in excessive noise on the signal lines. Also, ensure that the RS232 or RS485 signal cable connections do not exceed the following lengths:

- RS232 Cable: 50 feet maximum
- RS485 Cable: 4,000 feet maximum

ELECTRICAL WIRING CONNECTIONS Instructions

8. To permit Modbus control of the ECS/SP, refer to Table 2-2, below, and connect the appropriate wire leads to the Temperature Controller terminals listed. Refer to the Temperature Controller (Eurotherm 2408) pinouts shown in Figure 2-8 to locate the required terminals. Also, refer to Appendix A for instructions on how to change the Temperature Controller Modbus address and for a listing of active Modbus data addresses for the 2408 Controller. In addition, the Eurotherm documents referenced in this Appendix provide additional communication information related to Modbus.

NOTE: The complete wiring diagram for the SmartPlate Electronic Control System is provided in Appendix B of this Instruction Manual. In addition, the wiring connections for Control Box Terminal Blocks TB-1 and TB-2 are also provided for reference purposes.

NOTE: AERCO recommends that shielded, twisted-pair cable be used for communication wiring. Examples of suitable wiring are: Belden 9841, 8761, 3105A, or equivalent.

TABLE 2-2. Modbus Communication Signal Connections

2408 TEMP. CONTROLLER		COMPUTER CONTROL CABLE			
			RS232/9-PIN	RS232/25-PIN	RS485
SIGNAL NAME	PIN NO.	SIGNAL NAME	PIN NO.	PIN NO.	PIN NO.
GROUND	HD	GROUND	5	7	GROUND
RECEIVE	HE	TRANSMIT	3	2	A(-)
TRANSMIT	HF	RECEIVE	2	3	B(+)

2408 CONTROLLER

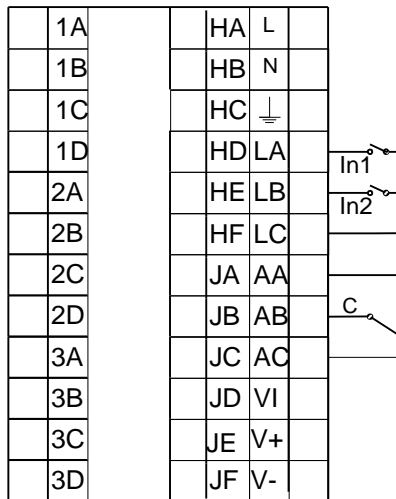

SEE TABLE 2-2 FOR COMM CONNECTIONS

Figure 2-8. Temperature Controller (Eurotherm 2408) Terminal Connection Diagram

2.6 Additional Component Installation

A number of SmartPlate Water Heater components are included in an installation kit. These parts must be installed after the unit is setup at the site.

There are six installation kits. The parts in each kit depend on the SmartPlate model, the pressure option, and whether it is being installed in New York City.

Kit #	Applies to SmartPlate Models	Pressure	NYC Option
58128-1	SP23, SP33, SP45, SP69, SP150 SPDW23, SPDW32, SPDW42, SPDW61, SPDW113	150 PSI	No
58128-2	SP23, SP33, SP45, SP69, SP150 SPDW23, SPDW32, SPDW42, SPDW61, SPDW113	200 PSI	
58128-3	SP23, SP33, SPDW23, SPDW32	150 PSI	Yes
58128-4	SP45, SP69, SP150, SPDW42, SPDW61, SPDW113		
58128-5	SP23, SP33, SPDW23, SPDW32	200 PSI	
58128-6	SP45, SP69, SP150, SPDW42, SPDW61, SPDW113		

The contents of the kits are shown below (see Appendix E for a full list and quantity per kit)

Part #	Description
92070	Air Vent Valve 1" 150 PSI
92130	Air Vent Valve ¾", 200 PSI
92065-1	Relief Valve, ¾M X ¾F, 150 PSI
92134-1	Relief Valve, 200 PSI
92111	Relief Valve
93521	Reducing Bushing, 1 ½" to ¾"
93505	Reducing Bushing 1" to ¾"
93451	Nipple, ¾", 2" Lg.

Complete the instructions below to install Relief Valve and Air Vent valves.

ADDITIONAL COMPONENT INSTALLATION Instructions

- If you have a 150 PSI unit, install the parts as shown in Figure 2-9.

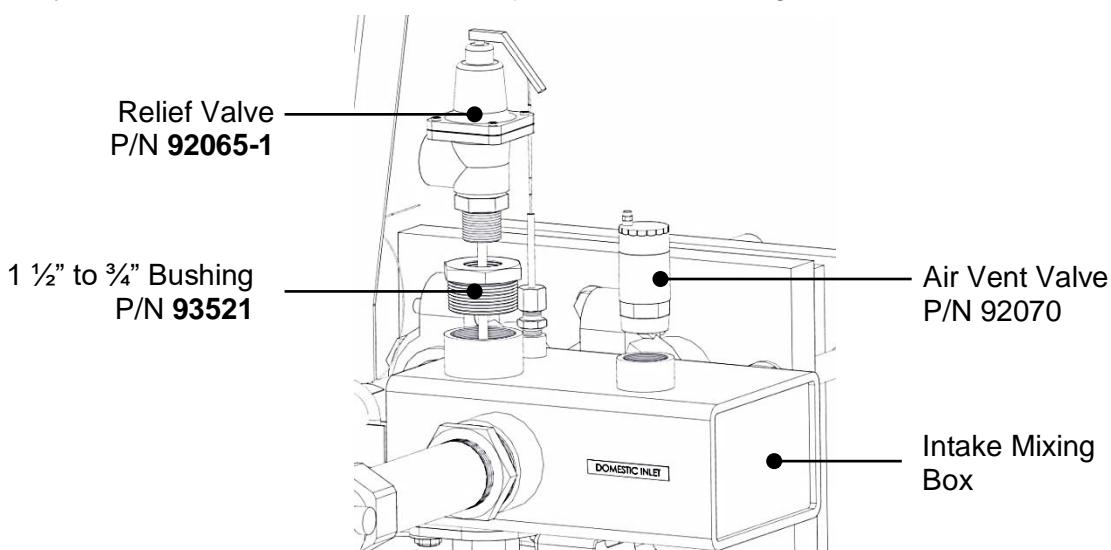

Figure 2-9. Relief Valve and Air Vent Valve Installation – 150 PSI – Exploded

ADDITIONAL COMPONENT INSTALLATION Instructions

2. If you have a 200 PSI unit, install the parts as shown in Figure 2-10.

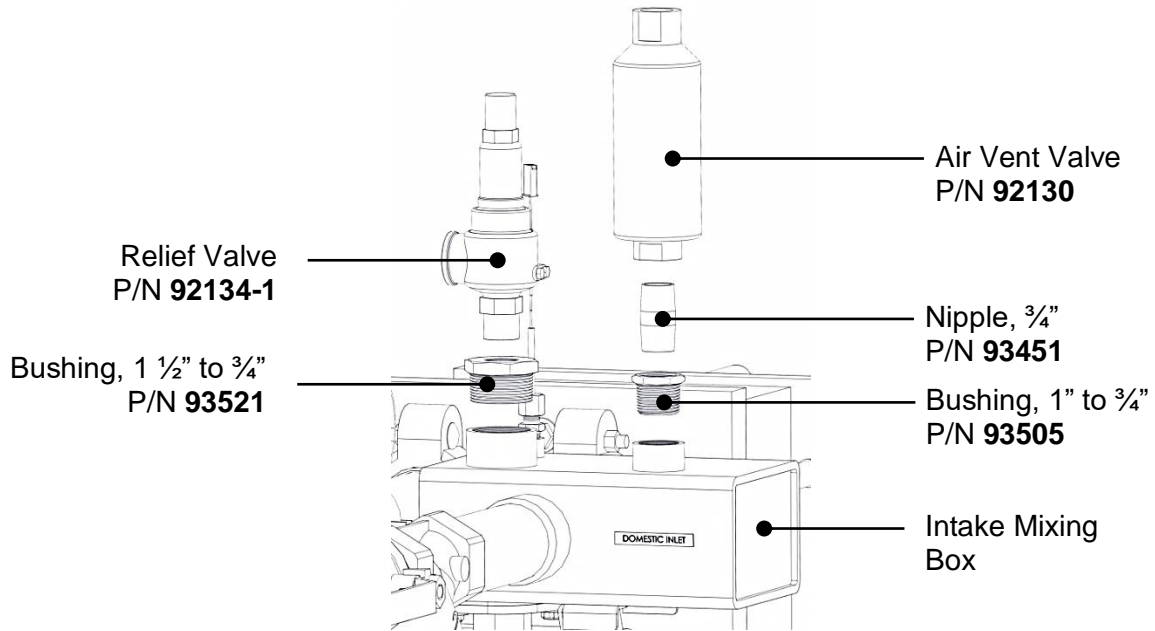

Figure 2-10. Relief Valve and Air Vent Valve Installation – 200 PSI – Exploded

3. If the unit is being installed in New York City only (kits **58128-3 – 58128-6**), in addition to the steps above you must install a second Relief Valve (P/N **92111**) in the Boiler Water Intake Ball Valve/Strain combo, as shown in Figure 2-11. If the unit has 2 inch piping (models SP-42, SP-61 or SP-113), you must include the 1" to 3/4" bushing (P/N **93505**). Units with 1 1/2" piping do not need this bushing.

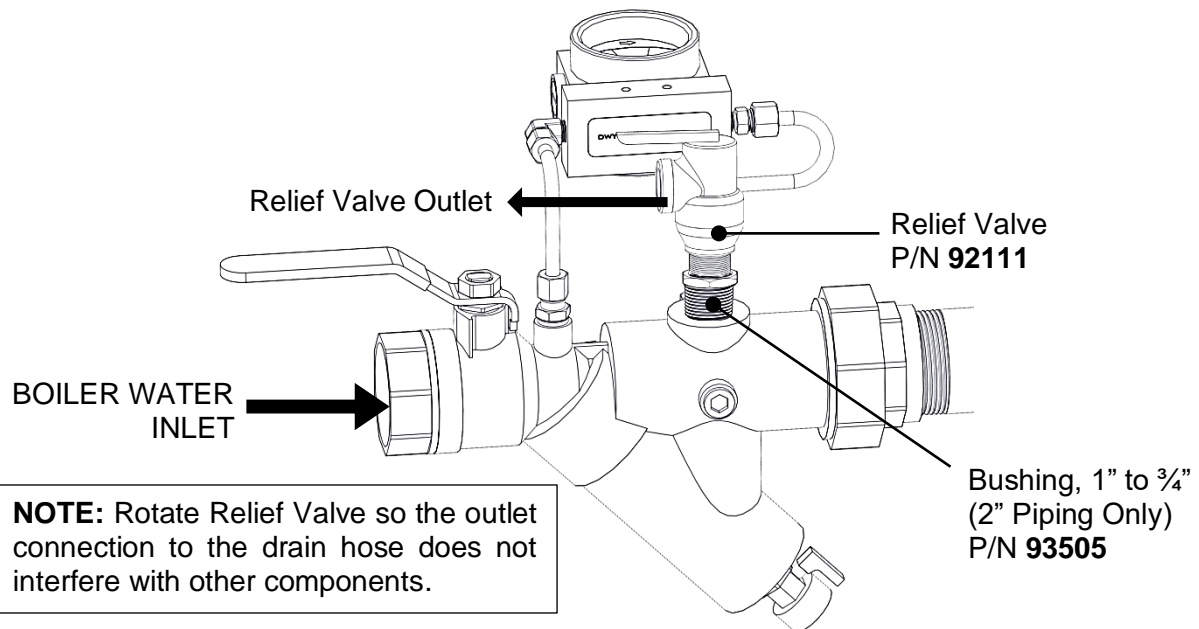

Figure 2-11. Relief Valve Installation – New York City Option

CHAPTER 3. FUNCTIONAL DESCRIPTION

3.1 Introduction

SmartPlate Water Heaters are equipped with a stainless steel plate heat exchanger, an ECS/SP Electronic Control System, and an MXG-461 Control Valve. This design results in a highly responsive system which provides virtually constant hot water flow at the selected setpoint temperature.

Accessories included with SmartPlate Water Heaters include:

- Boiler water and domestic water Y-strainers with blow-down valves
- Relief Valve
- Air Vent Valve
- Isolation valves and domestic water drain valve
- Boiler water differential pressure gauge
- Domestic water air vent
- Integral domestic water circulator pump

A simplified functional block diagram for the SmartPlate Water Heater is shown in Figure 3-1. The following sections provide a top-level functional overview of system operation.

3.2 Mechanical Overview

The cold water enters heat exchanger through the inlet connection, strainer, and mixing box. Cold water flows through the plate heat exchanger, where it is heated by hot boiler water, and then discharged through the Domestic Hot Water (DHW) outlet connection. A portion of hot water is pumped into the mixing box where it is mixed with the cold water entering the heater, thereby providing a load sensing feed forward function.

Boiler water supplied to the heat exchanger passes through the inlet connection and strainer. The boiler water heats the colder domestic water, and is then discharged through the boiler water outlet connection. The boiler water flow is controlled by the 3-way MXG-461 Control Valve which is located in the outlet path of the boiler water piping connection. If desired, the Control Valve configuration can be changed to a 2-Way Valve by closing the Ball Valve located between the boiler water inlet connection and port B of the Valve (see Figure 3-1). However if this 2-Way configuration is used, ensure that a by-pass line is installed in the boiler water piping (outside the unit) to avoid dead-heading the boiler water pump.

For SmartPlate models with Double-Wall heat exchangers, heat transfer plates are positioned together to form one assembly with an air space between them. This protects against leakage of boiler water into the domestic water. If one of the plates should develop a leak (boiler water or domestic water, whichever is leaking), the water will enter the air space and exit to the atmosphere. It will flow out through leak detection channels alerting an operator that a leak has occurred.

3.3 Electronic Control Overview

The primary control mechanism for the ECS/SP is an Electronic Process Controller which is installed in the Control Box. The Controller utilizes feed forward and PID (Proportional Integral

Derivative) algorithms to provide precise control of the unit's outlet temperature. Outlet temperature control is accomplished by modulating the open/closed position of the MXG-461 Control Valve Actuator.

The Controller continuously monitors the unit's outlet temperature via a thermocouple located in the outlet port. The Controller also receives a feed-forward signal from the temperature sensor mounted in the mixed water mixing box as shown in Figure 3-1. The mixed water sensor monitors flow changes through the unit and provides a feed-forward signal to the Controller proportional to the change in flow. The mixed water temperature provides an instantaneous feed-forward response for loads ranging from 0.5 GPM to the maximum Water Heater flow. The Water Heater uses a cartridge circulator to create reliable mixed flow conditions in the mixing box.

The Controller provides a 0-to-10 VDC output signal to the MXG-461 Control Valve Actuator. This 0 to 10 VDC signal proportionally modulates the Control Valve position from fully closed (0 VDC) to fully open (10 VDC). The control signal varies as necessary to maintain the setpoint temperature programmed into the Controller. Under normal conditions, the unit's outlet temperature is maintained within $\pm 4^{\circ}\text{F}$ of the desired setpoint based on a load change of 50% or less. Surface-mount sensors and digital displays are also provided in the ECS/SP Control System to monitor the supply and return water temperatures of the boiler water.

3.4 Over-Temperature Control and Safety Features

The Control Box contains an Over-Temperature Switch which continuously monitors and displays the unit's outlet water temperature from input received from the thermocouple installed in the hot water outlet port. Normally, the Over-Temperature Switch is set 20°F above the unit's setpoint temperature. If the programmed over-temperature limit is exceeded, the Over-Temperature Switch is activated. This in turn sounds an audible alarm, disconnects power from the Control Valve Actuator moving the Control Valve to the full-bypass position (B – AB). It should be noted that the Over-Temperature Switch has a slightly slower response to temperature changes than the Temperature Controller. Therefore, slightly different temperature readings may appear momentarily in their respective displays, particularly during system start-up.

The Control Valve Actuator also incorporates a "Fail-Safe" feature which automatically closes the valve if there is a loss of the 0 to 10 VDC control signal or loss of input power. The 24 VAC power supply transformer has an integral 3 amp circuit breaker to protect the Control Valve electronics.

CHAPTER 3 – FUNCTIONAL DESCRIPTION

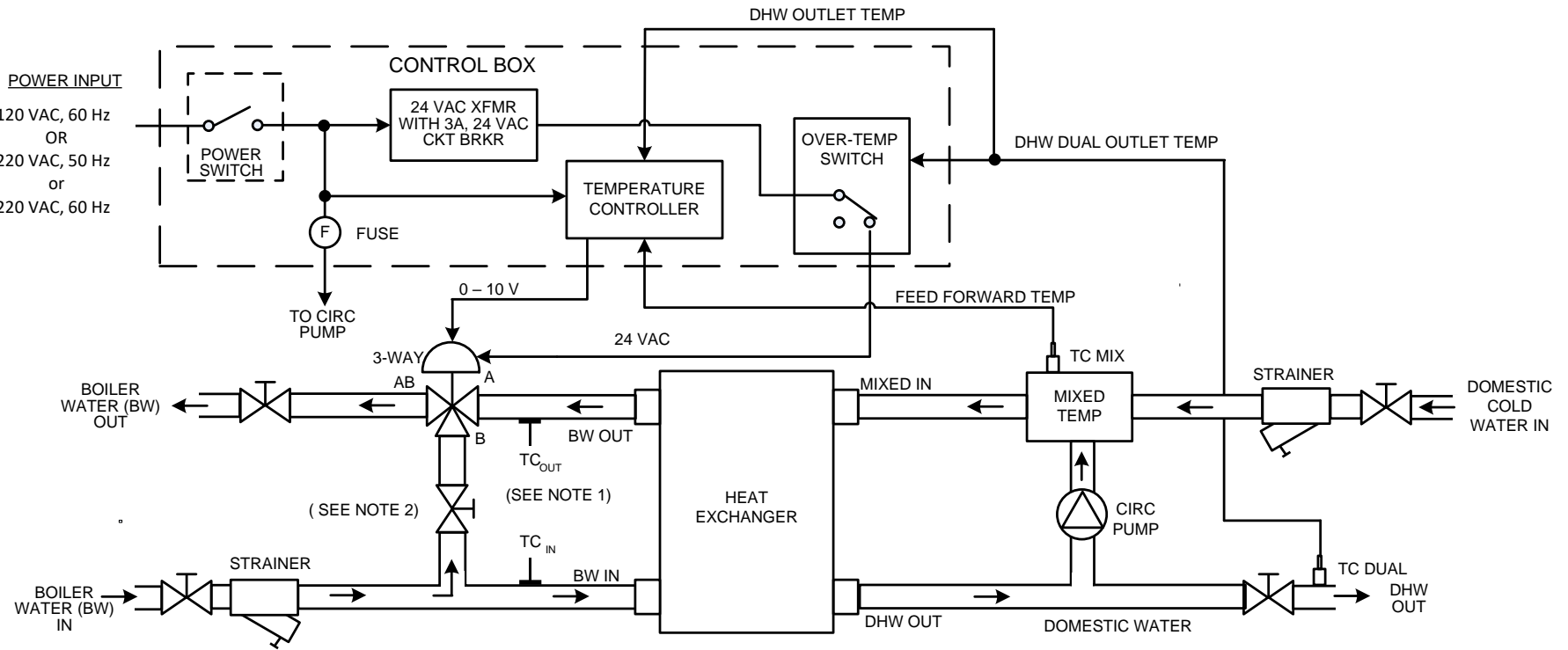

NOTES:

1. THE BW TC IN & BW TC OUT THERMOCOUPLES ARE CONNECTED TO DISPLAY DEVICES IN THE CONTROL BOX. THESE ARE "INDICATION ONLY" DISPLAYS WHICH MAY BE USER-CONFIGURED FOR ALARM SETTINGS.
2. THE BOILER WATER BYPASS LINE IS NORMALLY OPEN (3-WAY VALVE CONFIGURATION). FOR A 2-WAY CONFIGURATION, CLOSE THE VALVE ON THE BYPASS LINE. ENSURE THAT A BYPASS LINE IS INSTALLED EXTERNAL TO THE SMART PLATE.

Figure 3-1. SmartPlate Water Heater Functional Block Diagram

(This Page Is Intentionally Blank)

CHAPTER 4. ADJUSTMENT

4.1 Introduction

This chapter provides the adjustment procedures for the 3-Way Control Valve, MXG-461 and the SmartPlate Electronic Control System (ECS/SP).

Prior to shipment from AERCO, all MXG-461 Control Valve Actuators are adjusted (auto-stroked) to ensure that they properly position the Control Valve from the fully-open to the fully-closed positions. In addition, the ECS/SP is adjusted to the Setpoint Temperature specified on the Sales Order.

It is recommended that the following procedures be performed to the extent necessary prior to placing the SmartPlate Water Heater into operation. Also, the applicable procedures **MUST** be performed following replacement of the MXG-461 Control Valve or ECS/SP components to ensure that all parameters are properly set.

CAUTION!

As a precaution, ensure that all heating fluid hot boiler water shutoff valves are fully closed prior to performing any of the following adjustment procedures.

4.2 Smartplate 3-Way Control Valve, Mxg-461 Adjustment

The 3-Way Control Valves, (Siemens, MXG-461) used on all SmartPlate models are powered by 24 VAC. For SmartPlate Water Heater applications, each 3-Way Valve is controlled by a 0 to 10 VDC signal received from the Temperature Controller (Eurotherm 2408) contained in the ECS/SP. A 0 VDC signal places the Control Valve in the full bypass position from port B to port AB (valve shaft up). A 10 VDC signal places the Control Valve in the full flow position from port A to port AB (valve shaft down).

4.2.1 Control Valve Calibration And Status Indications

The control Valve Actuators are self-calibrating for all Valve sizes. Therefore, simply proceed as follows to automatically adjust the Valve Actuator:

CONTROL VALVE CALIBRATION Instructions

1. Refer to Figure 4-1 and loosen the two (2) captive screws securing the cover on the Electronics Module of the MXG-461 Control Valve.

CONTROL VALVE CALIBRATION Instructions

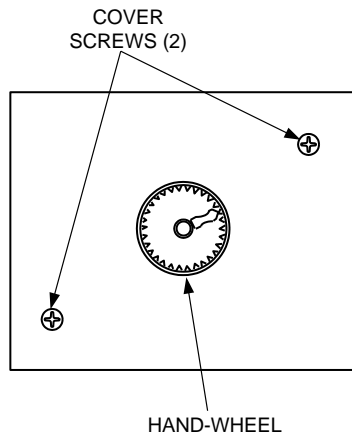

Figure 4-1. Control Valve Electronics Module – Top View

- Remove the Electronics Module cover from the Valve to access the internal components shown in Figure 4-2

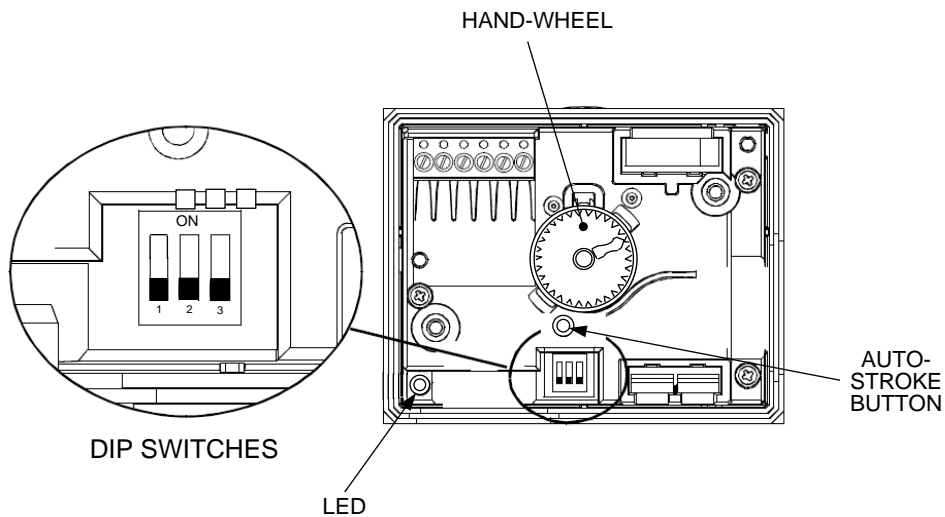

Figure 4-2. Control Valve with Electronics Module Cover Removed

NOTE: When external 120/240 VAC power is properly connected to the ECS/SP Control Box, 24 VAC power is supplied to the MXG-461 Control Valve when the Control Box POWER switch is set to the ON position. The POWER switch is located on the right side of the Control Box.

- Ensure that all three (3) DIP switches shown in Figure 4-2 are in the OFF (Down) position as shown.

CONTROL VALVE CALIBRATION Instructions

4. Set the ECS/SP Control Box POWER switch to the ON position to apply 24 VAC power to the Control Valve Actuator (pins 1 (G0) and 2 (G)). Ensure the Valve is in the AUTO position, the LED indicator will light green continuously indicating that Valve operation is normal (no faults).
5. Using a pin or paper clip, depress the auto-stroke button in the opening of the terminal housing (Figure 4-2). This will initiate calibration of the Control Valve.
6. During actuator calibration, the LED indicator (Figure 4-2) will flash green for approximately 10 seconds. The Control Valve will be briefly closed and fully opened.
7. Upon successful completion of the Valve calibration process, the LED indicator will stop flashing and remain ON continuously green.
8. The two-color (Red/Green) indicator is useful in determining the operating status of the Control Valve. Refer to Table 4-1 for descriptions of the possible LED status displays which may be encountered.

TABLE 4-1. Control Valve MXG-461 LED Status Indicators

LED Display	Status	Description
LED green	On continuously	Automatic Mode (normal, no faults)
	Flashing	- Mechanically set to MANUAL - Mechanically set to OFF - Currently in Auto-Calibrate Mode
LED red	On continuously	- General fault - General calibration fault - Microprocessor fault
	Flashing	- Faulty 24 VAC supply (Too low)
LED	Off	- No 24 VAC supply - Electronics Module fault

9. Turn off power to the Control Valve by setting the ECS/SP Control Box POWER switch to the OFF position.
10. Replace and secure the Electronics Module cover by tightening the two captive screws.

WARNING!

MANUAL CONTROL OPERATION OF THE 3-WAY VALVE DISABLES THE OVER-TEMPERATURE & POWER LOSS SAFETY SHUTDOWN FEATURES OF THE SYSTEM. MANUAL OPERATION IS ONLY USED FOR PROBLEM DIAGNOSIS.

4.2.2 Manual Control Of 3-Way Valve – Removable Handwheel To Hamper Tampering

If desired, the control path (A-to-AB) of the Control Valve, (Siemens, MXG-461) can be opened manually up to 95% of full-stroke. Refer to Figure 4-3 and proceed as follows:

MANUAL CONTROL OF 3-WAY VALVE Instructions

1. Remove the water heater from service prior to using the manual operating mode.
2. Press the handwheel inward and rotate it clockwise to the MANUAL position. This will disable the 0 to 10 VDC control signal from the ECS/SP Temperature Controller. The Valve can now be mechanically rotated. The temperature control system is now disabled. Be sure to return to the AUTO mode prior to returning the system to heating service use (see step 4).
3. To disable automatic control of the Valve, press the handwheel inward and rotate it counterclockwise to the OFF position. This will close the Valve.
4. To set the Valve for automatic (AUTO) operation, rotate the handwheel to the AUTO position. The handwheel will pop up when in the AUTO position, thereby allowing it to be controlled by the ECS/SP Temperature Controller.

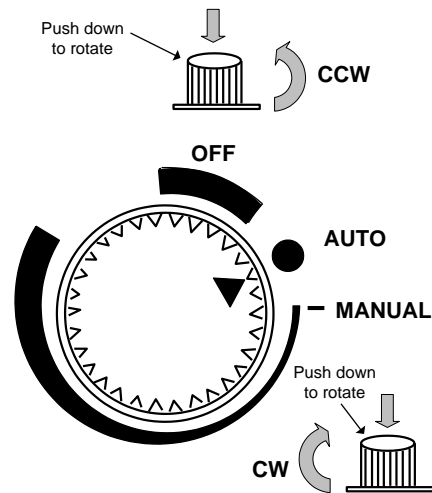

Figure 4-3. Control Valve Auto, Manual and Off Positions

The SmartPlate Electronic Control System (ECS/SP) is preset at the setpoint temperature specified on the Sales Order. The over-temperature alarm limit is normally set 20°F above the specified setpoint. If no setpoint or over-temperature alarm limit is specified, the ECS/SP will be set to the Factory Default values of 140°F (setpoint) and 160°F (over-temperature alarm limit). If changes are required, the setpoint and over-temperature alarm limits can be easily changed. This is accomplished using the controls provided on the Temperature Controller and the Over-Temperature Switch contained in the Control Box shown in Figure 4-4. These items can be viewed through the window on the front door of the Control Box. To access these controls and adjust the setpoint or over-temperature alarm limit, open the hinged Control Box door. Proceed as indicated in sections 4.2.3 or 4.2.4 to adjust the required parameters:

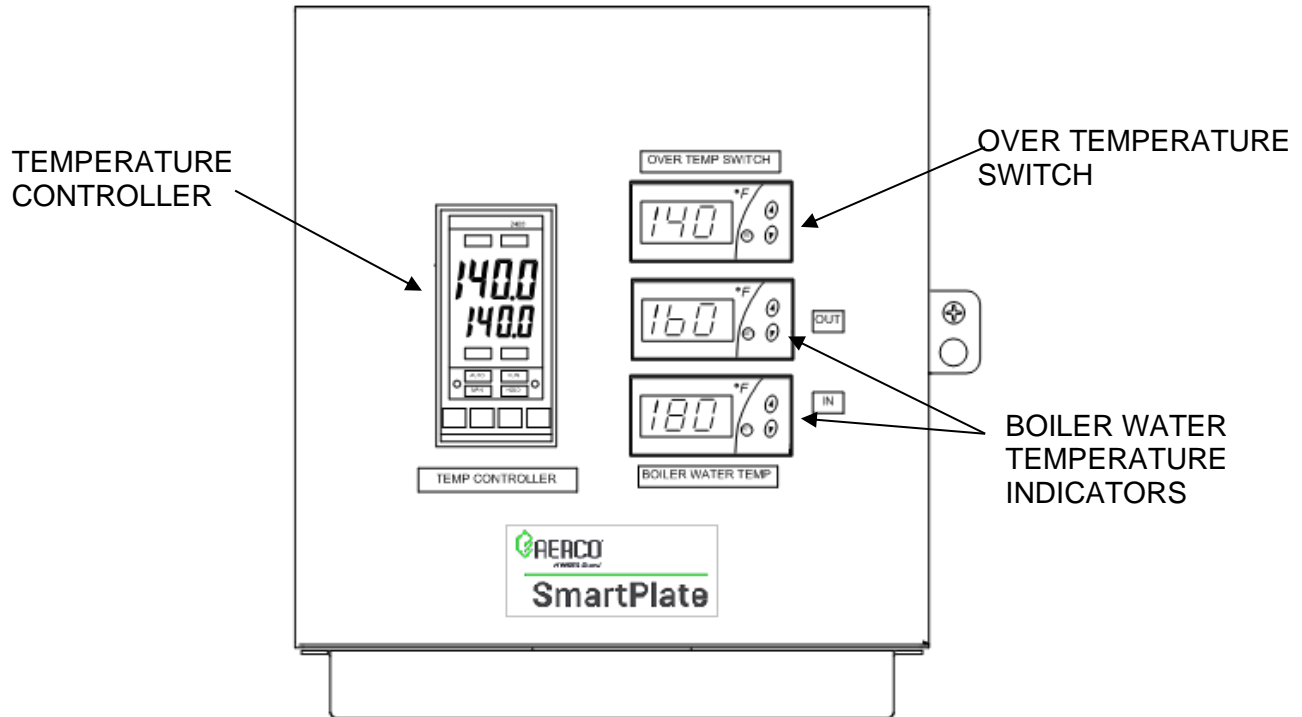

Figure 4-4. Control Box – Front View

NOTE: When the Power Switch on the Control Box is set to the ON position, it also energizes the internal 24 VAC Transformer in the Control Box. This in turn provides 24 VAC power to the Control Valve Actuator, provided that the water temperature at the heater outlet is below the high temperature limit setting.

4.2.3 Setpoint Temperature Adjustment

The setpoint temperature is adjusted using the controls and displays provided on the Temperature Controller (Eurotherm 2408). These controls and displays are illustrated and described in Figure 4-5 and Table 4-2. If necessary, setpoint temperature adjustment is accomplished as follows:

SETPOINT TEMPERATURE ADJUSTMENT Instructions

1. With the Control Box door open, set the ON/OFF POWER switch on the right side to the ON position. The Temperature Controller will initiate a self-test for approximately 3 seconds. Following the self-test, the top display will show the current outlet water temperature of the unit and the lower display will show the current setpoint temperature stored in memory (default = 140°F).
2. Ensure that the Temperature Controller is set to the AUTO (automatic) mode and the AUTO indicator is lit. If the MAN indicator is lit, press the AUTO/MAN button to toggle the mode setting. Indicator OP1 should also be lit.
3. If the lower display does not show the desired setpoint temperature, press the ▲ or ▼ arrow button to change the display to the desired value.

SETPOINT TEMPERATURE ADJUSTMENT Instructions

- Two seconds after the ▲ or ▼ arrow button is released, the display will blink to indicate that the Temperature Controller has accepted and stored the displayed value.

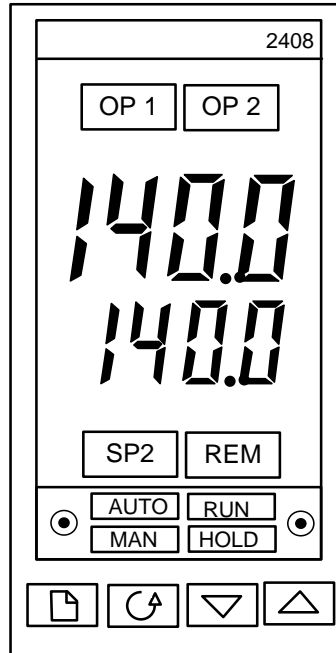

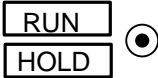





Figure 4-5. Temperature Controller

SETPOINT TEMPERATURE ADJUSTMENT Instructions		
TABLE 4-2. Temperature Controller Operating Controls, Indicators & Displays		
CONTROL or INDICATOR	MEANING	FUNCTION
OP1	Output 1 Indicator	OP1 lights when a 0 to 10 VDC signal is being supplied to the ECSSP Valve Actuator
OP2	Output 2 Indicator	Not used for the ECS/SP application
SP2	Setpoint 2 Indicator	Not used for the ECS/SP application
REM	Remote Setpoint Indicator	REM lights when the ECS/SP is set up to be controlled by a Remote (Modbus) signal. REM will also flash when Modbus communication is active.
	Auto/Manual Button and Indicators	When button is pressed, the Controller is toggled between the automatic (AUTO) and manual (MAN) modes. When first set to manual the valve will close and show zero percentage (0 %) on the display. <ul style="list-style-type: none"> AUTO lights when in the automatic mode. (Setpoint temperature setting appears in lower display) MAN lights when in the manual mode. (Valve percent open appears in lower display)
	Run/Hold Button and Indicators	Not used for ECS/SP application
(a) 	Page Button	Press Page button to select a new list of parameters
(b) 	Scroll Button	Press Scroll button to select a new parameter in a list
(c) 	Down Button	Press to decrease the value shown in the lower display
(d) 	Up Button	Press to increase the value shown in the lower display

4.2.4 Over-Temperature Alarm Limit Adjustment



The over-temperature alarm limit setting is adjusted using the controls and display on the Over-Temperature Switch. The alarm limit is normally set 20°F above the specified setpoint. The controls and display are illustrated and described in Figure 4-6 and Table 4-3. If necessary, over-temperature alarm limit adjustment is accomplished as follows:

REPOSITIONING ECS/SP CONTROL BOX Instructions

1. With the Control Box door open, set the ON/OFF POWER switch on the right side to the **ON** position.
2. Press the **SET** button on the Over-Temperature Switch. SP will appear in the display.
3. Press the **SET** button again. The current over-temperature limit value stored in memory will be displayed. (default = 20°F above setpoint specified on Sales Order, or 160°F if no setpoint is specified).
4. If the display does not show the desired over-temperature alarm setting, press the ▲ or ▼ arrow button to change the display to the desired temperature setting.
5. Once the desired over-temperature alarm setting is displayed, press the **SET** button to store the setting in memory.
6. To calibrate the offset (P1), press and hold the **SET** button for 8 seconds on the Over-Temperature Switch. Access code value 0 is shown in the display. The switch comes from the factory with the code set at 0. AERCO recommends that you do not change this code.
7. Press the **SET** button again to enter the code. The first parameter label (SP) will appear in the display.
8. Using the ▲ and ▼ arrow keys, select parameter P1.
9. Press **SET** to view the value stored in memory.
10. If the desired value is not displayed, modify the setting using the ▲ and ▼ arrow keys. The value can be changed from -10° to +10° offset. Press **SET** to enter the value and exit to the text parameter.
11. To exit the programming mode, press the **SET** and ▼ buttons simultaneously, or simply wait one minute and the display will automatically exit the programming mode.
12. Once the programming mode has been exited, the display will show the unit's current outlet water temperature.



Figure 4-6. Over-Temperature Switch

REPOSITIONING ECS/SP CONTROL BOX Instructions		
TABLE 4-3. Over-Temperature Switch Controls and Indicators		
CONTROL or INDICATOR	MEANING	FUNCTION
LED Display	TEMP status	Displays current water temperature or setpoint.
RST	RESET Button	Resets the unit after an alarm condition.
	UP Button	Increases the displayed temperature.
	DOWN Button	Decreases the displayed temperature.
SET	SET Button	Used to access and store parameters in the unit.

(This Page Is Intentionally Blank)

CHAPTER 5. OPERATION

5.1 Introduction

This chapter provides the pre-operational checks, initial start-up and operating procedures for SmartPlate Water Heaters.

WARNING!

FLUIDS MUST BE GRADUALLY INTRODUCED TO THE UNIT. FAILURE TO DO SO CAN CAUSE DAMAGE TO HEAT EXCHANGER PLATES. WHEN UNIT IS EMPTY OR COLD, DO NOT ADMIT HOT FLUID TO THE UNIT SUDDENLY. WHEN UNIT IS HOT, DO NOT SHOCK WITH COLD FLUID.

CAUTION!

Do NOT operate equipment exceeding design conditions as specified on the nameplate. SmartPlate Water Heaters must never be subjected to pressure greater than the maximum differential pressure specified on the nameplate. Sudden rises in pressure may cause leakage or damage to plates or gaskets of double-wall models and damage single-wall heat exchangers.

5.2 Pre-Operational Checks & Procedures

All SmartPlate Water Heater installation procedures in Chapter 2 must be fully completed prior to performing Pre-Operational checks. In addition, the following items should be checked:

PRE-OPERATIONAL CHECKS & PROCEDURES Instructions

1. Ensure that external single-phase AC power at 120 VAC/60 Hz or 240 VAC/50 Hz is properly connected to the ECS/SP Control Box.
2. Verify that the ECS/SP Temperature Controller setpoint and Over-Temperature Switch alarm limit have been properly set using the procedures in Chapter 4 - *Adjustment*.
3. Open the isolation valve in the unit' cold water inlet line (see Figure 1-1).
4. The air vent, located in the top of the mixing box, allows air to escape during the fill process (a hissing sound may be heard). If a hissing sound is not heard through the air vent, close the air vent cap and then open it 2 full turns counterclockwise. Do Not remove the air vent cap.
5. On 150 PSI units, when the hissing sound from the air vent stops, carefully open the Relief Valve to vent any remaining air, and then close the Relief Valve when the heater is full.

5.3 Initial Start-Up

In order to prevent a possible over-temperature condition during initial start-up, AERCO recommends that the following steps be performed in the order specified:



INITIAL START-UP Instructions

1. With the ECS/SP Control Box door open, set the POWER switch on the right side of the box to the ON position. This will power the complete ECS and MXG-461 Control Valve. When power is initially applied, the ECS/SP Temperature Controller automatically performs a self-test sequence for ~ 3 seconds. Proceed immediately to the next step.
2. The Temperature Controller will show the present water heater outlet temperature in the upper display and the setpoint temperature in the lower display.
3. Press the AUTO/MAN button on front panel of the Temperature Controller (Figure 4-5) and toggle to MAN (Manual) mode. The MAN indicator lights when Manual mode is selected.
4. When in the Manual mode, the upper display will continue to show the current outlet water temperature of the heater. The lower display will show the position of the MXG-461 Control Valve Actuator in %. When the Manual mode is initially selected, the lower display will show 0%, indicating that the Control Valve is fully closed.
5. Open the stop valve in the building recirculation system, if employed.
6. Open the isolation valve in the hot water outlet line. Connect a hose to the field-piped "Hose Connection" (see Piping Diagrams in Appendix C) or open several hot water fixtures in the building to ensure water flow through the heater.
7. Slowly open the isolation valves in the boiler water inlet and boiler water outlet connections of the heater.
8. Using the ▲ arrow button, set the MXG-461 Control Valve to the 10% position and monitor the outlet water temperature of the heater.
9. Next, continue to increase the valve "open" position in 5% increments until the water temperature starts to increase at a moderate rate.
10. When the outlet water temperature has increased to within 20°F of the desired setpoint, press the AUTO/MAN button and toggle the Temperature Controller to the AUTO mode. The AUTO indicator will light and the MAN indicator will go off. When in the AUTO mode the upper display will continue to show the outlet water temperature of the heater. The lower display will show the selected setpoint temperature.
11. When in the AUTO mode, the ECS will stabilize at the selected setpoint temperature (see Chapter 3). Once stabilized, the ECS/SP is set for unattended operation with no further operator intervention.
12. Check the boiler water differential pressure gauge (Figure 1-1) to ensure that the indicator dial is in the green area. If the dial moves to the red or yellow area, refer to Chapter 8 *Corrective Maintenance*.
13. Close the hose connection or hot water fixtures opened in step 6.
14. During start-up of Double-Wall models, there may be some evidence of leakage prior to the plates and gaskets reaching their working temperature. If leakage continues, check to ensure that dimension "A" in Figure 5-1 is correct within $\pm 1\%$ of the value shown on the channel plate assembly instructions. (Refer to Chapter 8, section 8.7.1 for details).

5.4 Checking Mixed Inlet Temperature

If desired, the water heater mixed inlet temperature can be monitored using the controls and displays on the Temperature Controller. This is accomplished as follows:

CHECKING MIXED INLET TEMPERATURE Instructions

1. Press the **Page** () button and select **iP**.
2. Next, press the **Scroll** () button and scroll to **Li.2**.
3. When **Li.2** is shown in the upper display, the lower display will show the water heater mixed inlet temperature. The temperature will be displayed for several seconds and then the Controller will revert to the default displays (outlet water temperature and setpoint).

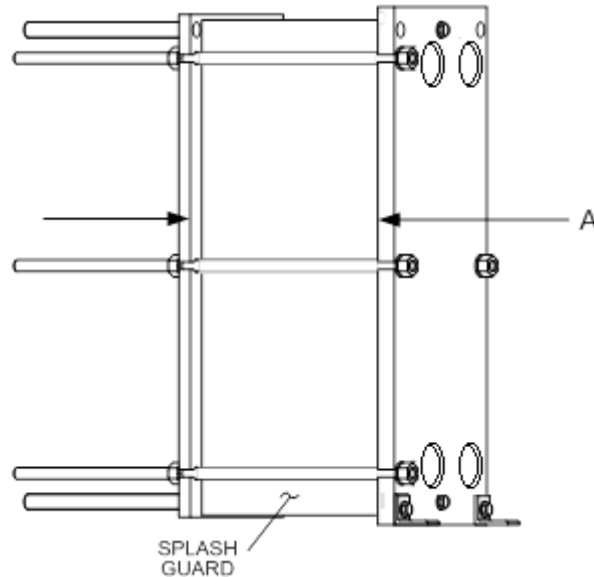

Figure 5-1. Double-Wall Heat Exchanger Only

5.5 Shutting Down the System

To shut down the Water Heater for a short period of time, simply turn OFF power and close the isolation valves as described in steps 1 and 2 below. However, if the unit will be shut down for an extended period of time, it will be necessary to drain the unit using the appropriate steps listed below for the type of heat exchanger used (single-wall or double-wall):

SHUTTING DOWN THE SYSTEM Instructions

1. Turn the POWER switch on the side of the ECS/SP Control Box to **OFF**.
2. Close all four of the Isolation Ball Valves (Figure 8-1).
3. Connect a drain hose to the Strainer on the Boiler Water side of the piping assembly (Figure 5-2). Open the valve on the Strainer and drain the boiler water from the unit. It will be necessary to loosen a Victaulic coupling by the heat exchanger to allow air into the pipe during draining.
4. Next, connect a hose to the Drain Valve on the DHW Side of the piping assembly. Open the Relief Valve to allow air into the pipe during draining.

SHUTTING DOWN THE SYSTEM Instructions

5. Open the Drain Valve to drain the domestic water from the unit.
6. After the boiler water and domestic water have been drained from the unit, close the Relief Valve opened in step 4 and tighten the Victaulic coupling loosened in step 3.

CAUTION!

Step 7 applies ONLY to SmartPlate Double-Wall models. Skip step for Single-Wall models.

7. For SmartPlate Double-Wall Water Heater models, it is also advisable to separate and clean the plates using the procedures in Chapter 8, section 8.6.2. Leave the double-wall heat exchanger in an un-tightened or slightly tightened condition. Cover the heat exchanger with dark plastic to protect it from welding light and dirt (rubber gaskets are sensitive to welding light). Do not store organic solvents or acids in the room. Avoid heat or ultraviolet light.

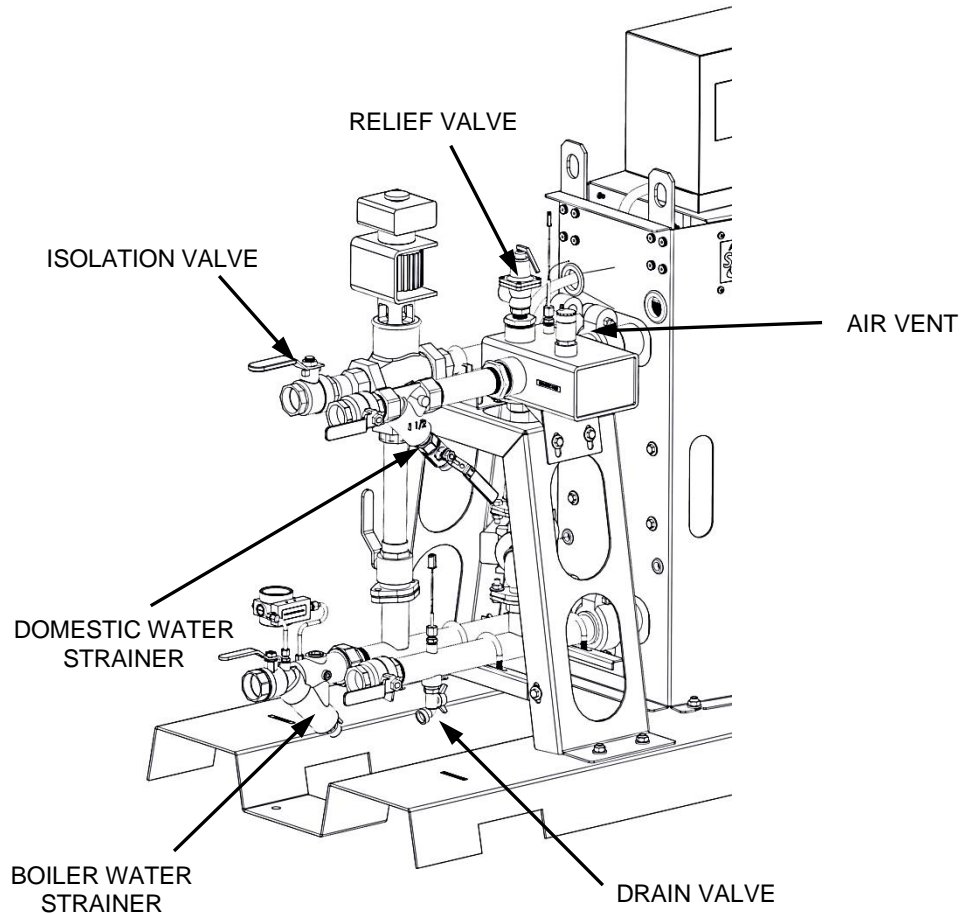

Figure 5-2. Typical SmartPlate Piping

8. To place the Water Heater back in service, fill the unit and perform the pre-operational checks and start-up procedures described in sections 5.2 and 5.3.

CHAPTER 6. SCHEDULED MAINTENANCE

6.1 Introduction

SmartPlate Water Heaters require regular routine maintenance to keep the unit operating at optimum efficiency. AERCO recommends that the tasks listed in Table 6-1 – Scheduled Maintenance Action, be performed at the periodic intervals specified. Table 6-1 consists of three columns arranged as follows:

- Interval Column. The Interval column contains alphabetical symbols which list all of the recommended scheduled maintenance tasks contained in this chapter. The following interval symbols shall be used in the order of increasing intervals: **W** (Weekly), **Q** (Quarterly), **S** (Semi-Annually), **A** (annually) and **P** (periodic).
- Maintenance Action Column. This column lists the required maintenance action which corresponds to the interval symbol in the previous column.
- Reference Column. This column lists the section number containing the required procedure.

TABLE 6-1. Scheduled Maintenance Actions		
Interval	Maintenance Task	Reference
W	Check Boiler Water Differential Pressure Gauge.	6.2
W	Double-Wall Only: Check plate packs for leakage	6.3
Q	Every 3 months, check the operation of the Over-Temp Switch in the ECS/SP Control Box	6.4
Q, S	After the first 3 months, check the operation of the Control Valve in the Boiler Water piping. Then, check operation every 6 months.	6.6
S	Every 6 months, check the Strainers on both the Boiler Water and Domestic Water Piping.	6.5
A	Once each year, check the Temperature Sensors	6.7
A	Once each year, check the operation of the Recirculation Pump	6.8
P	Periodic cleaning of the heat exchanger may be necessary, depending on conditions and settings.	6.9

6.2 Boiler Water Differential Pressure Gauge Check

Once a week check the Differential Pressure Gauge on the unit's Boiler Water Inlet as follows:

BOILER WATER DIFFERENTIAL PRESSURE GAUGE CHECK Instructions

1. Refer to Figure 6-1 and locate the Differential Pressure Gauge.
2. Check to ensure that the Gauge reading is in the Green area on the dial.
3. If the Gauge is reading in the Red area of the dial, attach a hose to the blow-down valve at the base of the Strainer. Cycle the blow-down valve open and closed 6 times.
4. If the Gauge still reads in the Red area on the dial, you may have too much boiler water flow through the unit, or the strainer may be clogged. If the strainer has just been cleaned, try reducing the flow rate. Refer to Chapter 8 – *Corrective Maintenance* to repair or replace the Differential Pressure Gauge.
5. If the Gauge reading is in the Green area for 3 consecutive weeks, this maintenance task can be performed monthly, instead of weekly.

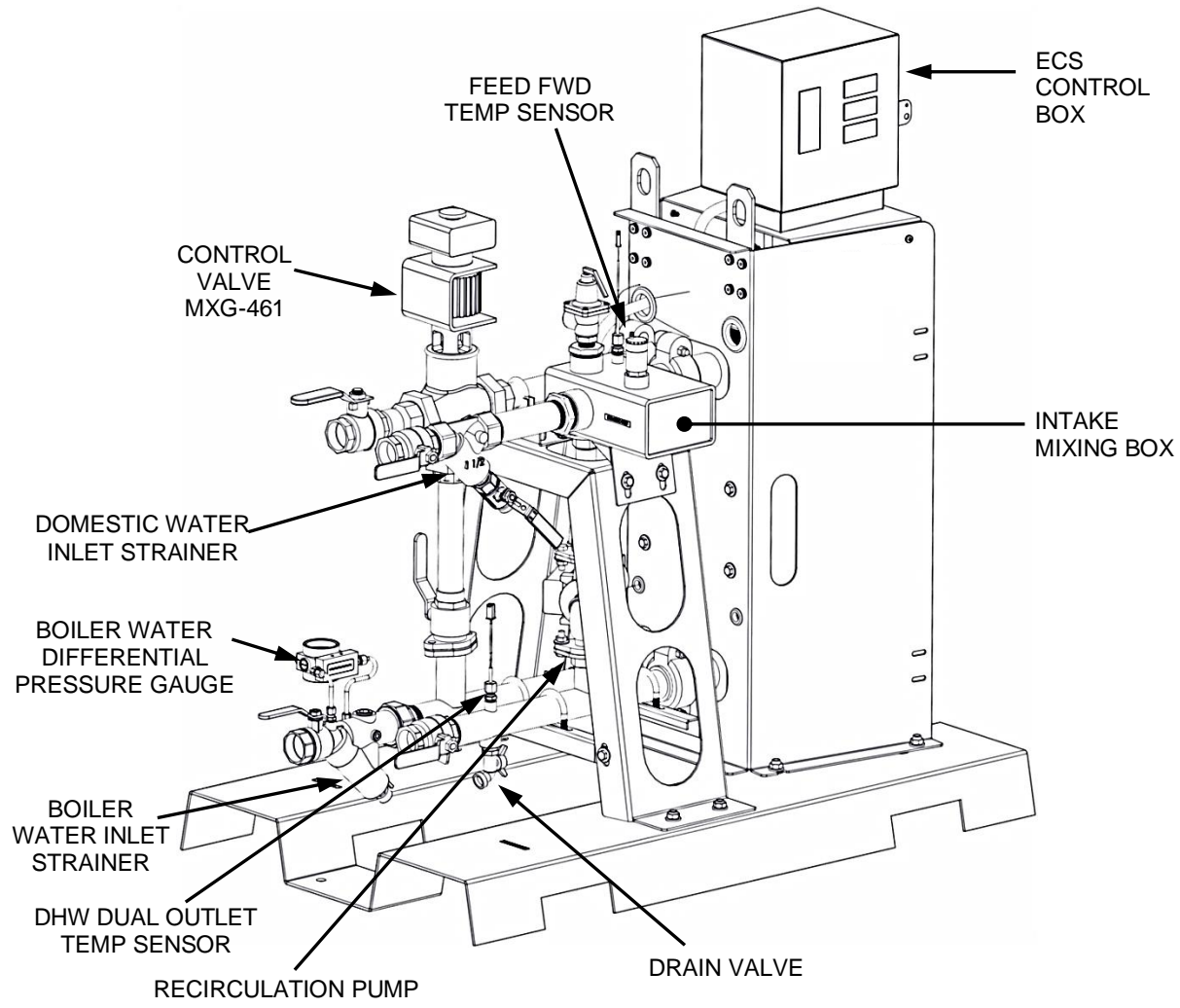

Figure 6-1. Location of Components for Scheduled Maintenance

6.3 Plate Pack Leakage Checks (Double-Wall Models Only)

For SmartPlate Double-Wall Water Heater models, check the Plate Pack for leaks as follows:

PLATE PACK LEAKAGE CHECKS Instructions

1. Remove the splash guard to access the Plate Pack (see Figure 5-1).
2. Check for leakage between the Plate Pack and Frame [see Figure 6-2 (A)].
 - a) If there is evidence of leakage, use a felt-tip marker to mark the area where the leakage appears to be coming from.
 - b) Refer to Chapter 8, sections 8.7 and 8.8 to correct the cause of the leakage.
3. Check for leakage between plates to the outside [see Figure 6-2 (B)]
 - a) If there is evidence of leakage, mark the area with a felt tip marker on the two plates next to the leakage.
 - b) Refer to Chapter 8, section 8.7 and 8.8 to correct the cause of the leakage.
4. If there is no evidence of leakage, replace the splash guard on the Plate Pack and return the unit to service use.

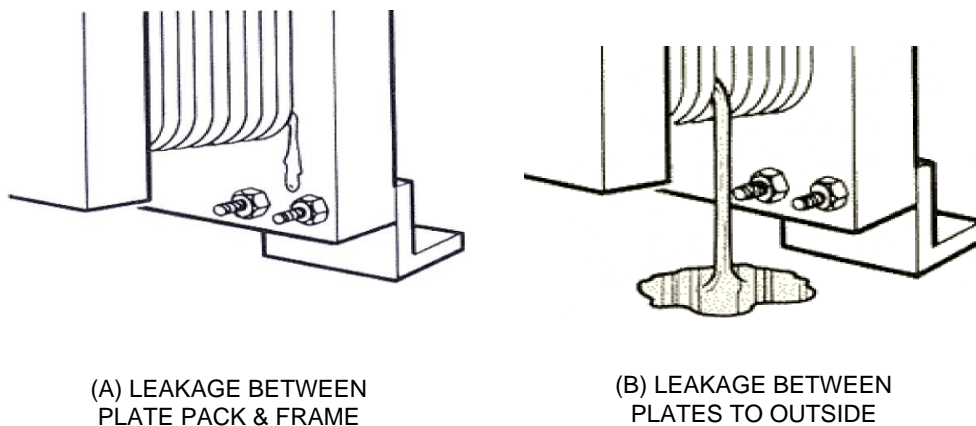

Figure 6-2. Double-Wall Heat Exchanger Leakage Checks - Splash Guard Removed

6.4 Over-Temp Switch Check

Every 3 months, check the Over-Temp Switch located in the ECS/SP Control Box as follows:

OVER-TEMP SWITCH CHECK Instructions

1. Refer to section 4.2.4 and lower the Over-Temp setting to approximately 5°F below the present setpoint temperature shown in the lower display of the Temperature Controller.
2. Verify that an Over-Temp Alarm is generated and the following events occur:
 - a) The Control Valve (Siemens MXG-461) closes.
 - b) The Over-Temp Switch generates an audible alarm.
3. Following successful completion of the Over-Temp alarm check, return the Over Temp Switch setting to its original setting (20°F above the unit's setpoint).

6.5 Strainer Inspection And Cleaning

Every 6 months, check and clean the Strainers in both the Boiler Water and Domestic Water piping of the unit. Perform the following steps for each Strainer:

STRAINER INSPECTION AND CLEANING Instructions

1. Attach a hose to the blow-down valve at the base of the Strainer. Cycle the blow-down valve open and closed 6 times.
2. If the Strainer cannot be cleared using the procedure described above, refer to Chapter 8 – *Corrective Maintenance*, section 8.12.

6.6 Control Valve Operational Check

Refer to Chapter 4, section 4.2 and recalibrate the Control Valve. Also, check the LED indicator to ensure the Valve is functioning correctly.

NOTE: To avoid repeated draining of the Water Heater, perform the annual scheduled maintenance checks specified in section 6.9 at the same time.

6.7 Temperature Sensor Checks

SmartPlate Water Heaters contain a Feed-Forward Temperature Sensor in the Mixing Box and a Dual Temperature Sensor in the DHW Outlet Port. Once each year, these Sensors should be checked to ensure there is no scale build-up.

TEMPERATURE SENSOR CHECKS Instructions

1. Turn the POWER switch on the side of the ECS/SP Control Box to **OFF** to disconnect AC power from the unit.
2. Close the Inlet and Outlet Isolation Valves on the Boiler Water and DHW lines of the unit.
3. Connect a hose to the Drain Valve and run it to a convenient floor drain. Open the Drain Valve near the DHW Outlet to drain the water from the pipes and heat exchanger.
4. Disconnect and remove the Single Feed-Forward Sensor from the Mixing Box and the Dual Outlet Temperature Sensor from the DHW Outlet Port (Figure 6-1).
5. Inspect the Sensors for evidence of scale build-up on the stainless-steel sleeve of the Sensors. If necessary, clean the Sensors using a wire brush.
6. In addition to the immersion Sensors mentioned above, check the attachment of the surface-mount Sensors on the Boiler Water Inlet and Outlet piping.

6.8 Recirculation Pump Check

The Recirc Pump is installed between the DHW inlet and outlet pipes beneath the Mixing Box.

WARNING!

PRIOR TO PERFORMING THE FOLLOWING STEPS, ENSURE THAT THE POWER SWITCH ON THE SIDE ECS/SP CONTROL BOX IS OFF AND THE HEATER HAS BEEN DRAINED AS SPECIFIED IN THE PREVIOUS SECTION.

PLATE PACK LEAKAGE CHECKS Instructions

1. Make sure that the POWER switch on the Control Box is OFF.
2. Ensure that the Drain Valve is open and the water has been drained from the unit.
3. Locate the Recirculation Pump and disconnect the flanges from the piping.
4. Carefully slide the Pump out and rotate to inspect. DO NOT pull on the electrical conduit when removing Pump.
5. If there is evidence of scale build-up, disconnect the conduit and electrical power connections from the Pump. Service or replace the Pump as necessary.
6. If there is no evidence of scale build-up on the Recirculation Pump, reinstall the Pump and reconnect the flanges.

6.9 Periodic Cleaning of Heat Exchanger

It may be necessary to de-scale the heat exchanger periodically, depending on water conditions and temperature settings. Section 8.2 describes the descaling process for the Water Heater’s heat exchanger.

The frequency of cleaning can be determined locally based on the performance of the heater and/or prior experience with similar equipment. Generally, the cleaning requirements will follow the trends shown in Table 6-2:

TABLE 6-2. Heat Exchanger Cleaning Guidelines				
Operating Conditions	Projected Cleaning Frequency			
	Rarely	Annually	Semi-Annually	Monthly
Boiler Water Inlet Temp	<150°F	~170°F	~200°F	~220°F
Domestic Water Setpoint	<130°F	140 - 160°F	160 - 180°F	
Calcium Hardness Level	<20 mg/L	20 - 40 mg/L	40 - 60 mg/L	>80 mg/L

If calcium hardness level, boiler water inlet temperature, and domestic water setpoint fall under different cleaning intervals in Table 6-2, the heat exchanger may be cleaned between those periods, starting with the most frequent interval. During the next few cleaning intervals observe how much scale is removed to determine if less frequent intervals can be followed.

Example:

BW inlet temperature = 180°F

Domestic water setpoint = 140°F

Calcium Hardness level = 40 mg/L

Heat exchanger Cleaning Frequency: Start out with semi-annually (every six months) schedule (180°F BW falls under semi-annually and the DHW setpoint and calcium hardness level fall under annually). Observe the next few cleanings on how much scale is removed to determine if an annual (yearly) cleaning frequency is more appropriate.

NOTE: Refer to section 8.2 and 8.5 for heat exchanger maintenance procedure.

CHAPTER 7. TROUBLESHOOTING

7.1 Introduction

The troubleshooting procedures provided in this chapter are intended to aid service and maintenance personnel in isolating the most probable cause of a fault in a packaged SmartPlate Water Heater. Prior to performing the troubleshooting steps and procedures in this chapter, perform the following preliminary checks:

TROUBLESHOOTING Instructions

1. Ensure that external AC power at 120 VAC or 220 VAC is being supplied to the SmartPlate ECS/SP Control Box.
2. Ensure all Electronic Control System (ECS/SP) electrical cable connections are secure.
3. Ensure that the Electronic Control Valve (MXG-461) is securely connected to the cable plug from the ECS/SP Control Box.
4. Check the fuse in the ECS/SP Control Box that supplies power the Recirculation Pump and Electronic Control Valve.
5. Ensure that both the upstream and downstream shut-off valves are fully open.
6. Check the circuit breaker on the 24 VAC Transformer inside the ECS/SP Control Box.

NOTE: In addition to the procedures in this chapter, check the troubleshooting sections of the Boiler Operation and Maintenance Manual used with the Water Heater and any other ancillary equipment manuals associated with the installation.

7.2 Troubleshooting Procedures

Troubleshooting procedures for SmartPlate Water Heaters are provided in Tables 7-1, 7-2 and 7-3. Table 7-1 provides troubleshooting procedures for the MXG-461 Control Valve and Piping Assembly components. Table 7-2 provides troubleshooting procedures for the ECS/SP Electronic Control System. Table 7-3 provides a troubleshooting guide to temperature control issues which may be encountered during Water Heater operation. Also, when troubleshooting ECS/SP faults related to the Temperature Controller (Eurotherm, model 2408), refer to Appendix A for additional information concerning process fault and diagnostic alarms.

1. Refer to the FAULT INDICATION column in the following tables and locate the fault that best describes the existing conditions.
2. Proceed to the PROBABLE CAUSE column and, if more than one item is listed, start with the first item shown for the fault condition.
3. Perform the corresponding checks and procedures listed in the CORRECTIVE ACTION column for the first PROBABLE CAUSE.
4. Continue checking each additional PROBABLE CAUSE for the existing fault until the fault has been corrected.
5. Refer to the applicable procedures in Chapter 8 – *Corrective Maintenance* if component removal and/or replacement is required.

TABLE 7-1. Troubleshooting – Control Valve MXG-461 and Piping Assembly			
No.	Fault Indication	Probable Cause	Corrective Action
T1	System not operating. Control Valve is closed and outlet water temp. is far below setpoint.	No power supplied to Control Valve Control signal not being supplied from Temp. Controller.	Remove Valve Electronics Module cover (Figure 4-1) and verify that 24 VAC power is present at pin 1 of terminal strip. Restore power if necessary. Proceed to Table 7-2 and check Over-Temp Switch and 24 VAC Transformer circuit breaker to ensure they have not tripped. Verify presence of a 0 to 10 VDC control signal at pin 5 of terminal strip. If control signal is not present, troubleshoot ECS/SP per Table 7-2.
T2	System over-heats by more than 10°F above the desired setpoint. Outlet temp is below Over-Temp limit setting	Control Valve is in the MANUAL mode. Control Valve not fully closed. Temp. Controller not set properly or defective. Control Valve not calibrated correctly Heat exchanger scaled on DHW side.	Ensure Control Valve is set to the AUTO mode. Check 0–10 VDC control signal to Actuator. If signal is greater than 0 VDC when heater outlet temp is 10°F (or more) above desired setpoint, proceed to next item in list. Refer to Chapter 4 and check current setting of Temp. Controller. Readjust if necessary. If adjustment does not clear fault, proceed to Table 7-2 and continue. Refer to Chapter 4, section 4.2 and auto-calibrate the valve by pressing the button (Figure 4-2). If Valve stem does not fully stroke up and down, contact AERCO for assistance. Clean and de-scale heat exchanger.

TABLE 7-1. Troubleshooting – Control Valve MXG-461 and Piping Assembly

No.	Fault Indication	Probable Cause	Corrective Action
T3	System outlet water temperature is below desired setpoint	<ol style="list-style-type: none"> 1. Boiler water inlet strainer is clogged 2. Boiler water temp is too low. 3. Boiler water flow rate too low. 4. Temp controller is not properly set. 5. Control Valve is not opening properly. 6. Heat exchanger is fouled on boiler water side. 7. Heat exchanger is scaled on boiler water side 8. Heat exchanger is too small for load. 	<ol style="list-style-type: none"> 1. Check the strainer differential pressure gauge. If gauge is in the “RED” area, blow down the strainer and re-check until gauge is in the “GREEN” area. 2. Check the Boiler Water IN temperature on the Control Box display indicator. Verify that the temperature is equal to the boiler water temperature to which the unit was sized. 3. Check system pump and measure flow rate to the Water Heater with an ultrasonic meter. 5. Refer to Chapter 4, section 4.2.3 and check the current setpoint temperature setting on the Temp Controller. If the setting is below the desired setpoint, readjust as necessary. 6. Remove Electronics module cover on Valve and view the Status LEDs. See Table 7-1A to check the Valve status. 7. Proceed as follows: <ol style="list-style-type: none"> a. Close isolation valves b. Clean strainers 8. Clean or de-scale heat exchanger. 9. Reduce load or resize heat exchanger.
T4	Wide variation in Water Heater outlet temperature during wide variations in flow	<ol style="list-style-type: none"> 1. ECS/SP mixed water temperature sensor is not functioning properly 2. DHW internal Recirculation Pump is not functioning properly 	<ol style="list-style-type: none"> 1. Refer to Table 7-2 and check the operation of the mixed water temperature sensor. 2. Proceed as follows: <ol style="list-style-type: none"> a. Check the fuse on the side of the ECS Control Box and replace if blown. b. Check input power to Recirculation Pump. c. Check the temperature of the copper tube above the Pump. It should be the same as the outlet DHW temperature. If cold, repair or replace pump as required.

TABLE 7-1. Troubleshooting – Control Valve MXG-461 and Piping Assembly			
No.	Fault Indication	Probable Cause	Corrective Action
T5	Rapid fluctuations in heater outlet temperature which <u>do</u> <u>not</u> follow load changes	1. Temp. Controller is not functioning properly.	1. Refer to Table 7-2 and troubleshoot the Temp. Controller.

TABLE 7-1A. Control Valve MXG-461 LED Status Indicators		
LED Display	Status	Description
LED green	On continuously	Automatic Mode (normal, no faults)
	Flashing	- Mechanically set to MANUAL - Mechanically set to OFF - Currently in Auto-Calibrate Mode
LED red	On continuously	- General fault - General calibration fault - Microprocessor fault
	Flashing	- Faulty 24 VAC supply (Too low)
LED	Off	- No 24 VAC supply - Electronics Module fault

TABLE 7-2. Troubleshooting – Electronic Control System (ECS/SP)			
No.	Fault Indication	Probable Cause	Corrective Action
T1	System not operating. All displays are blank.	<ol style="list-style-type: none"> External 120 VAC power disconnected. Defective fuse on side of Control Box. Defective ON/OFF switch on Control Box. 	<ol style="list-style-type: none"> Ensure external circuit breaker is ON. Check for 120 or 240 VAC power across TB-2 terminal leads 101 (Line) and 102 (Neutral). Check the fuse on the right side of the Control box. Replace if blown. Set ON/OFF POWER switch to the ON (Up) position and verify that the switch indicator lights. Also: <ol style="list-style-type: none"> Verify that 120 VAC is present across TB-2 terminal leads 101 (Line) and 102 (Neutral). If voltage not present, replace ON/OFF POWER switch.
T2	Temperature Controller is ON, but Temperature Indicators are blank	<ol style="list-style-type: none"> Circuit breaker tripped Defective 24 VAC transformer in Control Box 	<ol style="list-style-type: none"> Reset the circuit breaker on the 24 VAC step-down transformer. Check the 120 VAC or 240 VAC power on TB-2 (see Appendix B). Verify that 24 VAC is present across the Blue and Brown wires terminated on TB-1. If 24 VAC is not present, replace the 24 VAC transformer in the Control Box.
T3	Water Heater outlet temp. consistently above Setpoint by 10°F or more. However, temperature is below Over-Temp. limit setting.	<ol style="list-style-type: none"> Temp. Controller is not properly set. Faulty Temp. Sensor (thermocouple) is connected to Temp. Controller. 	<ol style="list-style-type: none"> Refer to Chapter 4 – <i>Adjustment</i> and check current setting of Temp. Controller. Readjust if necessary. Verify Outlet Temp Sensor is securely connected to cable plug. Replace the Dual Sensor if necessary
T4	Over-Temp Alarm occurs repeatedly. NOTE Audible alarms will be generated if Outlet Temp Sensor is open. Erroneous temperature readings will be displayed if Sensor is shorted.	<ol style="list-style-type: none"> Over-Temp Switch not properly set. Open or shorted Outlet Temp. Sensor (thermocouple) connected to Over-Temp. Switch. Over-Temp Switch is defective. 	<ol style="list-style-type: none"> Refer to Chapter 4 and check the current setting of the ECS Over-Temp. Switch. Readjust if necessary. Check thermocouple connections between Sensor connector plug and TB-1 terminal leads 111 (+) and 112 (-). If connections are secure, replace Dual Temp Sensor. Replace Over-Temp Switch.
T5	Boiler Water Inlet audible alarm activated	<ol style="list-style-type: none"> Boiler water temp. is greater than 250°F. Alarm setting is not correct. Indicator is defective. 	<ol style="list-style-type: none"> Correct the boiler water temperature supply to the Water Heater. Refer to section 4.2.4 to reset the alarm limit to 220°F Refer to Chapter 8, section 8.15 for replacement instructions.

TABLE 7-2. Troubleshooting – Electronic Control System (ECS/SP)			
No.	Fault Indication	Probable Cause	Corrective Action
T6	Over-Temp. Alarm condition cannot be cleared. Over-Temp Switch displays erroneous temperature readings	<ol style="list-style-type: none"> 1. Shorted Outlet Temp. Sensor. 2. Defective Over-Temp. Switch. 3. 3-Way Control Valve not closing fully during no-load conditions. 4. A “No-Flow” condition caused a gradual buildup of heat to the water in vessel. 5. Water Heater recirculation pump shut off or failed. 	<ol style="list-style-type: none"> 1. Replace Outlet Temp, Sensor. 2. Replace Over-Temp Switch. 3. Calibrate 3-Way Control Valve per section 4.2.1. 4. Open hot water valve at sink or tub outlet to see if fault clears. If there is no flow through heater, go to Probable Cause 5. 5. Check recirculation pump to ensure it is turned on and functioning properly. Also, check pump fuse on side of Control Box.
T7	Outlet water temp. far below Setpoint	<ol style="list-style-type: none"> 1. Incorrect Temp Controller setting 2. Defective Temp. Controller. 3. Heat exchanger fouled on Boiler Water side. 4. Defective Control Valve Actuator 5. Boiler water supply temp. is too low. 6. Boiler Failure 	<ol style="list-style-type: none"> 1. Refer to Chapter 4 and check the current setting of Over-Temp. Switch. Readjust if necessary. 2. Remove the cover from the Electronics Module of the Control Valve and verify that the Temp. Controller is generating a control signal greater than 0 VDC. If not replace Temp. Controller. 3. Clean Boiler Water Inlet Strainer. Clean heat exchanger. 4. Replace Valve Actuator (SEE TABLE 7.1) 5. Increase boiler water temperature. 6. Check operational status of Boiler.
T8	Wide fluctuations in outlet water temperature during large flow changes.	<ol style="list-style-type: none"> 1. Water Heater Recirculation Pump not operating. 2. Boiler water temperature drops below DHW setpoint during heavy demand, then recovers. 3. Boiler water temperature drops below DHW setpoint but does not recover until load is reduced. 4. Boiler water supply temperature is too high. 	<ol style="list-style-type: none"> 1. Check Control Box fuse and power to pump. 2. Install Boiler Water Buffer Tank to provide hot water reservoir for the Water Heater to draw from during large load swings. 3. The boiler water supply is under-sized. Add more boilers or reduce DHW usage. 4. Control Valve is not seating properly. See Chapter 4 and auto-stroke valve.

TABLE 7-2. Troubleshooting – Electronic Control System (ECS/SP)

No.	Fault Indication	Probable Cause	Corrective Action
T9	Temperature control not within specifications. Items T1 – T8 check out OK. Wide fluctuations in outlet water temperature under low flow conditions.	<ol style="list-style-type: none"> 1. Unexpected system dynamics. 2. Outlet Temp Sensor connected to Temp Controller gives inconsistent or intermittent readings. 3. Mixed Water Temp Sensor is open, shorted or gives inconsistent readings. 4. Recirculation Pump failure. 	<ol style="list-style-type: none"> 1. See Table 7-3 for Temperature Control Troubleshooting. 2. Replace Outlet Temp Dual Sensor at the Water Heater outlet port. 3. Replace Mixed Water Temp Sensor. 4. Replace Recirculation Pump
T10	Wide fluctuations in outlet water temperature under low flow conditions.	<ol style="list-style-type: none"> 1. Outlet Temp Sensor connected to Temp Controller gives inconsistent or intermittent readings. 2. Mixed Water Temp Sensor is open, shorted or gives inconsistent readings. 3. Recirculation Pump failure. 	<ol style="list-style-type: none"> 1. Replace Outlet Temp Dual Sensor at Water Heater outlet port. 2. Replace Mixed Water Temp Sensor. 3. Replace Recirculation Pump

NOTE: Refer to the Dynamic Temperature Control Settings specified in Table 7-3A when performing the Corrective Actions listed in Table 7-3 which follows. Adjustment of Pb, Pb2 and FFPb can be accomplished from the first menu level on the Eurotherm 2408 Controller. Refer to Chapter 4, section 4.2 for procedure.

TABLE 7-3. Troubleshooting Guide for Temperature Control Issues			
No.	Observation	Probable Cause	Corrective Action
T9-1	Too much valve oscillations or too wide outlet temperature oscillation at low flow	Low flow condition may be unsteady or at a critical value for the control system.	Increase the Proportional value (Pb and/or Pb2). Note: This may cause wider temperature deviation with change in domestic flow.
T9-2	Too wide a deviation in outlet temperature when domestic flow changes	Dynamic loop response time variation from the engineering development system. Many factors contribute to this type of dynamic system variation.	Decrease the Proportional value (Pb and/or Pb2) and/or decrease FeedForward (FFpb). Note 1: This may increase oscillations at low flow. Note 2: A change in FFpb will cause the valve to fully open initially and over temperature may occur. Be sure the domestic outlet is shut to prevent scalding.
T9-3	On decrease in flow, outlet temperature initially goes up but then under-shoots setpoint too much before coming to setpoint	Dynamic loop response time variation from the engineering development system. Many factors contribute to this type of dynamic system variation.	Increase Proportional (Pb or Pb2) first. If that has little or no effect then increase FeedForward (FFpb). Note: A change in FFpb will cause the valve to fully open initially and over temperature may occur. Be sure the domestic outlet is shut to prevent scalding.
T9-4	On increase in flow, outlet temperature initially goes down but then overshoots setpoint too much before coming to setpoint	Dynamic loop response time variation from the engineering development system. Many factors contribute to this type of dynamic system variation.	Increase Proportional (Pb or Pb2) first. If that has little or no effect then increase FeedForward (FFpb). Note: A change in FFpb will cause the valve to fully open initially and over temperature may occur. Be sure the domestic outlet is closed to prevent scalding.
T9-5	After a change in domestic flow, outlet temperature remains too far from setpoint for too long	Dynamic loop response time variation from the engineering development system. Many factors contribute to this type of dynamic system variation.	Decrease Proportional and/or decrease Integral (I1 and/or I2). Note: This may increase outlet temperature oscillations at lower flows.
T9-6	Over-temperature alarm or water temperature more than 10°F above the setpoint after a long period of non-usage.	Control valve not closing fully, allowing some hot boiler water to enter the heat exchanger without demand	Recalibrate the valve stroke using the auto-calibration method described in Chapter 4, section 4.2.1.

TABLE 7-3A. Dynamic Temperature Control Settings for SmartPlate Single- Water Heaters									
Unit Size (SP or SPDW)	Boiler Water Temp (Tbw)	Feed Forward Parameter (FFPb)	Proportional Band 1 (Pb)	*Integral 1 (I1)	* Derivative 1 (D1)	Proportional Band 2 (Pb2)	*Integral 2 (I2)	*Derivative 2 (D2)	*Gain Schedule Cutoff Temp (Gsch)
SP23 SPDW23	<=180 °F	-40	40	20	5	30	20	5	145
	<=200 °F	-40	50	20	5	40	20	5	145
	<=220 °F	-50	50	20	5	40	20	5	145
	<=250 °F	-50	60	20	5	50	20	5	145
SP33 SPDW32	<=180 °F	-50	50	20	5	40	20	5	145
	<=200 °F	-50	60	20	5	50	20	5	145
	<=220 °F	-60	60	20	5	50	20	5	145
	<=250 °F	-60	70	20	5	60	20	5	145
SP45 SPDW42	<=180 °F	-60	60	20	5	50	20	5	145
	<=200 °F	-60	70	20	5	60	20	5	145
	<=220 °F	-70	70	20	5	60	20	5	145
	<=250 °F	-70	80	20	5	70	20	5	145
SP69 SPDW61	<=180 °F	-80	60	20	5	55	20	5	145
	<=200 °F	-80	70	20	5	65	20	5	145
	<=220 °F	-95	70	20	5	65	20	5	145
	<=250 °F	-95	80	20	5	75	20	5	145
SP150 SPDW113	<=180 °F	-100	60	20	5	60	20	5	145
	<=200 °F	-100	70	20	5	70	20	5	145
	<=220 °F	-120	70	20	5	70	20	5	145
	<=250 °F	-120	80	20	5	80	20	5	145

(This Page Is Intentionally Blank)

CHAPTER 8. CORRECTIVE MAINTENANCE

This chapter provides the procedures to correct and repair faults detected during operation or isolated during troubleshooting of SmartPlate Water Heaters. The procedures in this chapter are divided into four sections as follows:

- Section 8.1 : Smartplate Single-Wall Heat Exchanger Models - Single-Wall heat exchangers do not include any serviceable assemblies and components. Therefore, the procedures in this section are limited to heat exchanger cleaning (de-scaling) removal and replacement.
- Section 8.1.2 – Double-Wall Heat Exchanger Corrective Maintenance. This section provides cleaning and corrective maintenance procedures for serviceable internal components of the double-wall heat exchanger.
- Section 8.1.3 – SmartPlate Wetted Components - All models. This section provides corrective maintenance for major assemblies and components which come in contact with boiler water or domestic hot water during Water Heater operation. These assemblies and components are used on all SmartPlate models (Single-Wall and Double-Wall).
- Section **Error! Reference source not found.**– SmartPlate Electronic Control System (ECS/SP). This section provides removal and replacement procedures for the internally mounted assemblies and components contained in the ECS/SP Control Box.

8.1 Smartplate Single-Wall Heat Exchanger Models

8.1.1 Single Wall Heat Exchanger Maintenance

Since the Single-Wall heat exchanger does not contain any serviceable items, the procedures in this section are limited to cleaning (de-scaling) and removal/replacement. These procedures are provided in sections 8.3 and 8.4 which follow.

8.1.2 Heat Exchanger Cleaning & De-Scaling

Heat exchanger cleaning and de-scaling is accomplished "in-place" using the procedure below.

NOTE: The "in-place" cleaning/de-scaling procedure described below can also be used for Double-Wall heat exchangers (Section II) if not clogged with hardened scale deposits.

HEAT EXCHANGER CLEANING Instructions

1. Set the POWER Switch on the ECS/SP Control Box to the **OFF** position to stop the Recirculation Pump.
2. Close all four Water Heater Isolation Ball Valves (Figure 8-1).
3. Connect a hose to the Drain Valve near the DHW Outlet.
4. Remove the 1" NPT Air Vent from the top of the Mixing Box.

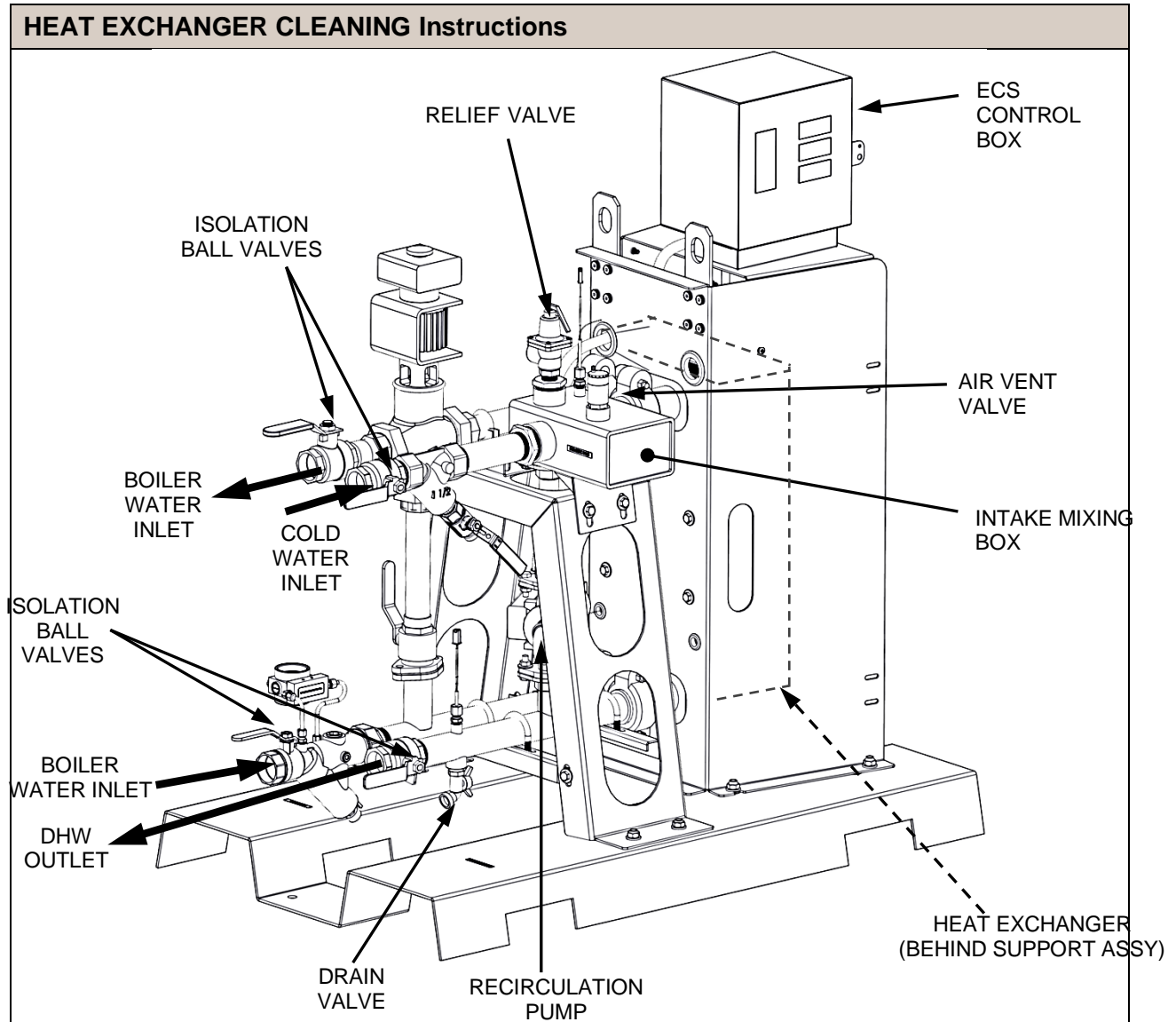

Figure 8-1. SmartPlate Isolation Valve Locations

5. Refer to Table 8-1 to determine the approximate amount of water to drain from the heat exchanger.

IMPORTANT!

The De-Scaling Solution used must be compatible with wetted materials of stainless steel, copper, brass and bronze. AERCO recommends creating a cleaning solution of Rydlyme Chemical Descaler (from Apex Engineering Products Corp.) and water. Contact Apex Engineering Products to obtain this product and instructions for its use.

HEAT EXCHANGER CLEANING Instructions		
TABLE 8-1. Cleaning Solution Required For Heat Exchanger De-Scaling		
SmartPlate Model	Heat Exchanger Volume (gallons)	Cleaning Solution Required (Gallons)
Single-Wall Heat Exchangers		
SP23	1.7	0.9
SP33	2.4	1.2
SP45	3.4	1.7
SP69	5.2	2.6
SP150	11.3	5.7
Double-Wall Heat Exchangers		
SPDW23	2.0	1.0
SPDW32	2.8	1.4
SPDW42	3.7	1.9
SPDW61	6.0	3.0
SPDW113	10.2	5.1

6. Drain at least half of the heat exchanger volume shown in the above Table for the SmartPlate model being de-scaled.
7. While making sure that the Drain Valve is tightly closed, pour the correct amount of cleaning solution into the Air Vent opening in the Mixing Box.
8. Add water as needed until the Mixing Box is full.
9. Replace the 1” NPT Air Vent.
10. Set the Control Box POWER Switch to the **ON** position and ensure that the Recirculation Pump is operating.
11. Allow the cleaning solution to circulate through the heat exchanger and piping for 1 to 3 hours, depending on amount of scale deposit. Since the amount of scaling will be hard to estimate, it should be based on the time in service and water hardness.
12. Upon completion of the previous step, turn the POWER Switch on the Control Box to **OFF** to stop the Recirculation Pump.
13. Remove the 1” NPT Air Vent and open the unit’s Drain Valve.
14. Flush with fresh water for at least 3 minutes.
15. Next, close the Drain Valve and fill with fresh water.
16. Apply new thermal sealant (Loctite 565 or equiv. NSF61 approved) to the threads of the 1” NPT Air Vent and install it in the Mixing Box.
17. Open the four Isolation Ball Valves on the unit.
18. Turn the Control Box POWER Switch to **ON** to restart the unit and place it back in service using the start-up instructions in Chapter 5.

8.1.3 Single-Wall Heat Exchanger Replacement

The heat exchanger used in each SmartPlate Single-Wall model is removed and replaced using the following basic procedure:

SINGLE-WALL HEAT EXCHANGER REPLACEMENT Instructions

1. Turn the POWER switch on the side of the ECS/SP Control Box to **OFF**.
2. Close all four of the Isolation Ball Valves (Figure 8-1).
3. Connect a hose to the Strainer on the Boiler Water side of the piping assembly (Figure 8-2). Open the valve on the Strainer and drain the boiler water from the unit. It will be necessary to loosen a Victaulic coupling by the heat exchanger to allow air into the pipe during draining.
4. Next, connect a hose to the Drain Valve on the DHW Side of the piping assembly and then open the Relief Valve to allow air into the pipe during draining.

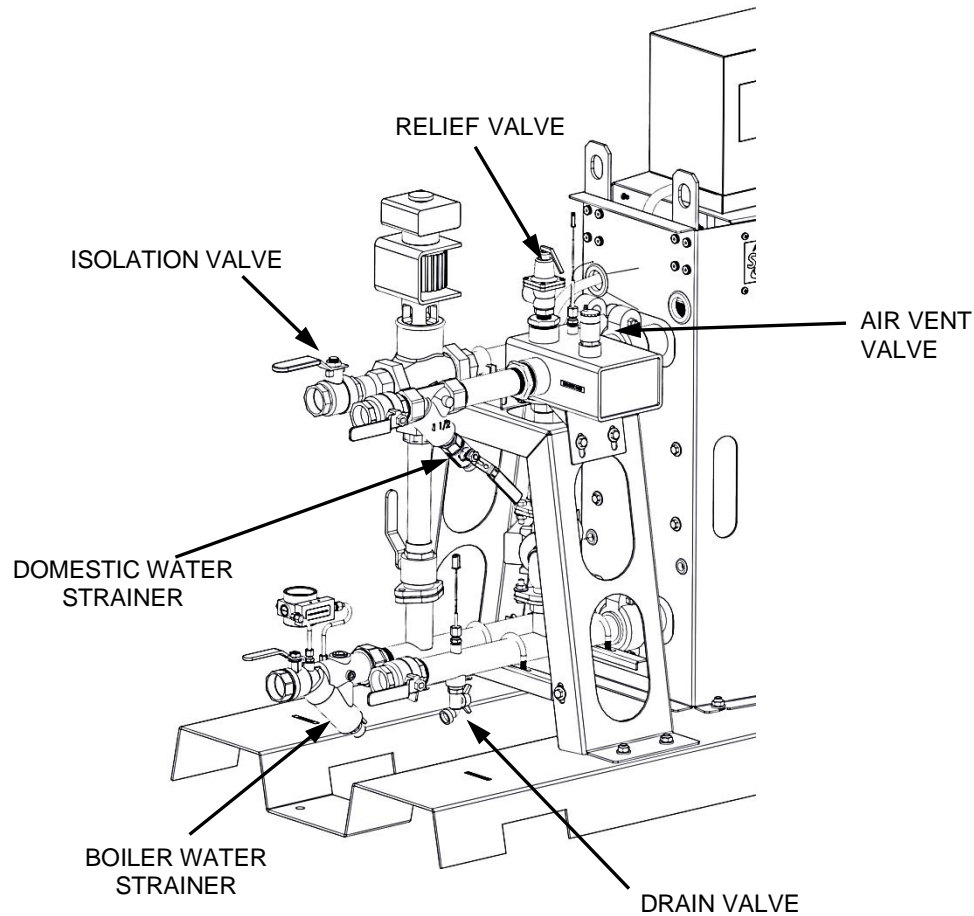

Figure 8-2. Draining the SmartPlate Water Heater

5. After the boiler water and domestic water have been drained from the unit, proceed to step 6 to remove the installed heat exchanger.
6. Close the Relief Valve opened in step 4.

SINGLE-WALL HEAT EXCHANGER REPLACEMENT Instructions

7. Using a ratchet wrench with an extension and a 3/4" deep socket, loosen, but do not remove, the four (4) Victaulic couplings (Figure 8-3). Two (2) couplings are located on the Domestic Water Side (Figure 8-3) and two (2) are located on the Boiler Water Side.
8. At the rear of the Water Heater, place a wooden block, or other suitable support, under the Brazed Plate heat exchanger to provide support while removing the mounting bolts in the following steps.
9. For SmartPlate model SP150, remove the two support brackets at the rear of the heat exchanger.
10. Use a ratchet with a 9/16" socket through the hand holes in the sides of the heat exchanger mounting bracket and a 9/16" wrench on the outside to remove the four (4) bolts, washers and nuts secure the heat exchanger to the Support Frame.

WARNING!

THE SINGLE-WALL HEAT EXCHANGER CAN WEIGH UP TO 300 POUNDS, DEPENDING ON THE SMARTPLATE MODEL. THEREFORE, USE EXTREME CARE WHEN REMOVING IT FROM THE MOUNTING BRACKET.

11. Carefully pull the heat exchanger away from the mounting bracket. It may be necessary to jiggle it to separate the grooved pipes from the Victaulic couplings.
12. To replace the heat exchanger with a new assembly, simply reverse the previous steps. Support the replacement heat exchanger and ensure it is properly aligned when installing the bolts squarely in the holes of the Support Frame. Tighten the bolts and all four Victaulic couplings.

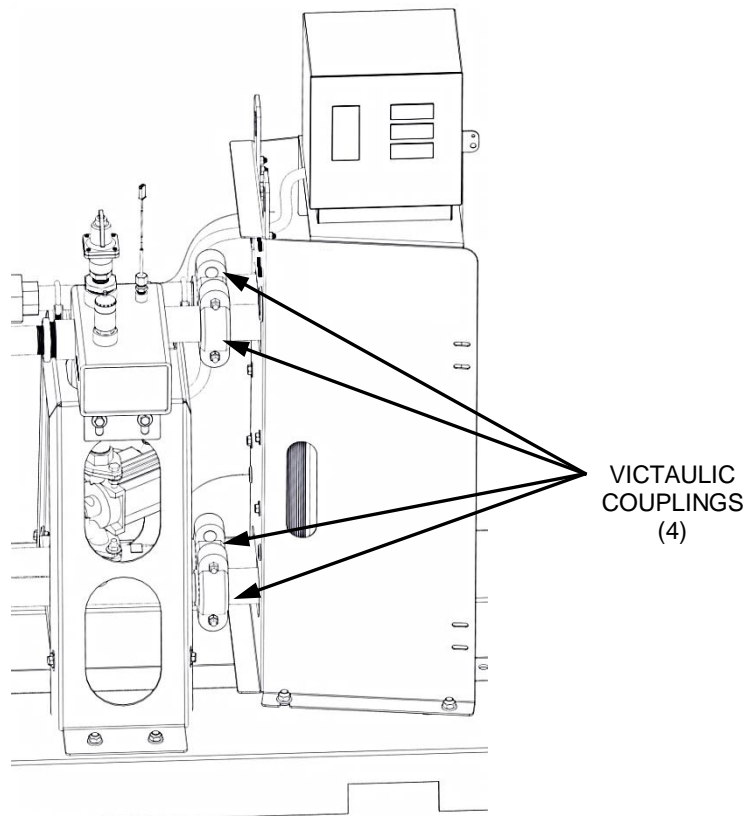
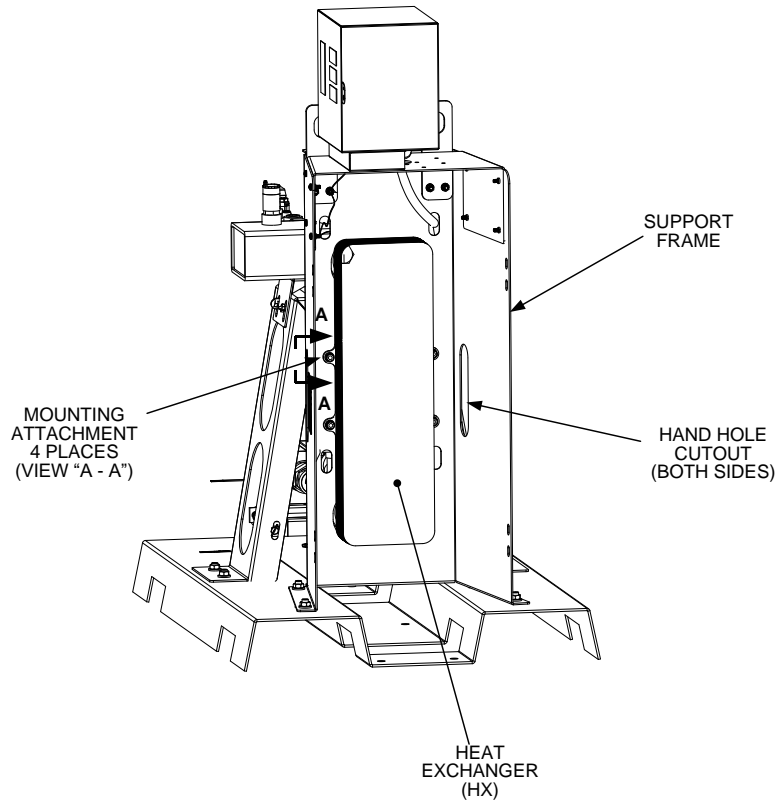
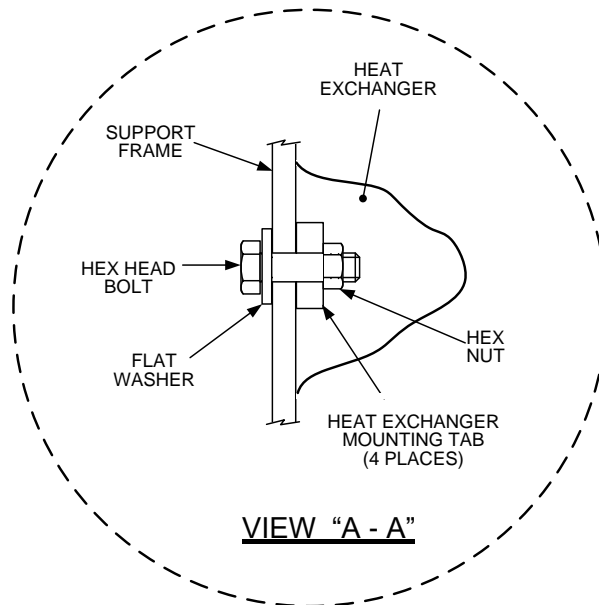

Figure 8-3. Domestic Water Side – Partial View

SINGLE-WALL HEAT EXCHANGER REPLACEMENT Instructions



REAR VIEW



VIEW "A - A"

Figure 8-4. Heat Exchanger Mounting Details

8.2 Smartplate Double-Wall Heat Exchanger Maintenance

The maintenance procedures for SmartPlate Double-Wall models (Figure 8-5) include procedures for:

- Cleaning (in-place or by disassembly)
- Opening/closing heat exchanger and removal/replacement of plate
- Replacement of gaskets
- Heat exchanger replacement

The procedures listed above are provided in sections 8.6 through 8.9.

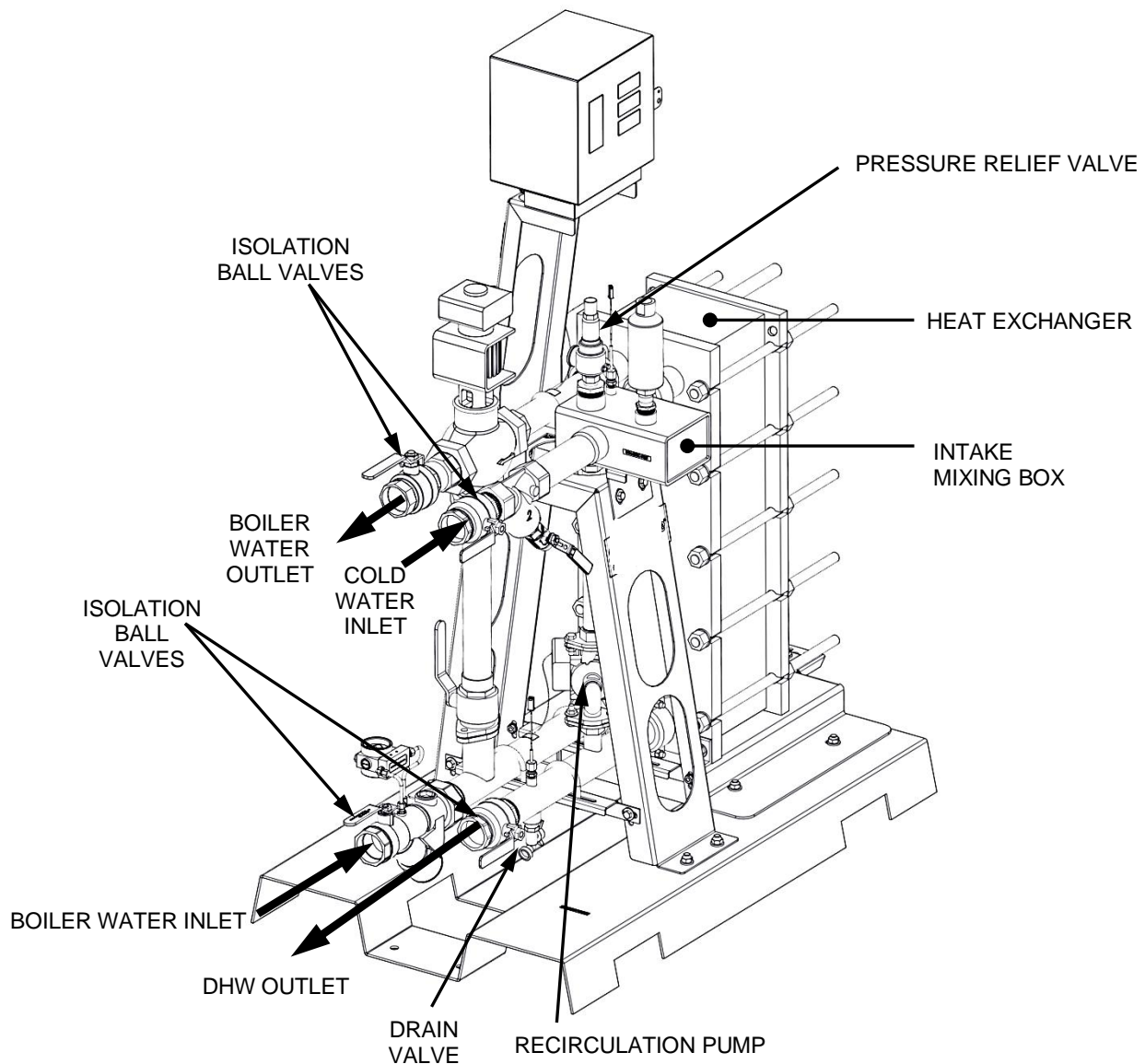

Figure 8-5. SmartPlate Double-Wall (Model SPDW61 Shown)

8.2.1 Double-Wall Heat Exchanger Cleaning

The Double-Wall heat exchanger can be cleaned in-place by circulating cleaning agents through the unit, or by disassembly.

8.2.1.1 Heat Exchanger Cleaning and De-Scaling (In-Place Method)

If the heat exchanger is not encrusted with hardened scale deposits, it can normally be cleaned by circulating cleaning solution such as Rydlyme Chemical Descaler (available from Apex Engineering Products Corp.) and clean water through the assembly. Perform the procedures specified in Section I, section 8.3 of this chapter.

8.2.1.2 Heat Exchanger Cleaning By Disassembly

If the heat exchanger is encrusted with hardened scale or sediment, the Water Heater will have to be drained and the Double-Wall heat exchanger opened as follows:

HEAT EXCHANGER CLEANING BY DISASSEMBLY Instructions

1. Set the POWER Switch on the ECS/SP Control Box to the OFF position to stop the Recirculation Pump.
2. Close all four Water Heater Isolation Ball Valves (see Figure 8-5, above).
3. Connect a hose to the Strainer on Boiler Water side of the piping assembly (Figure 8-6).

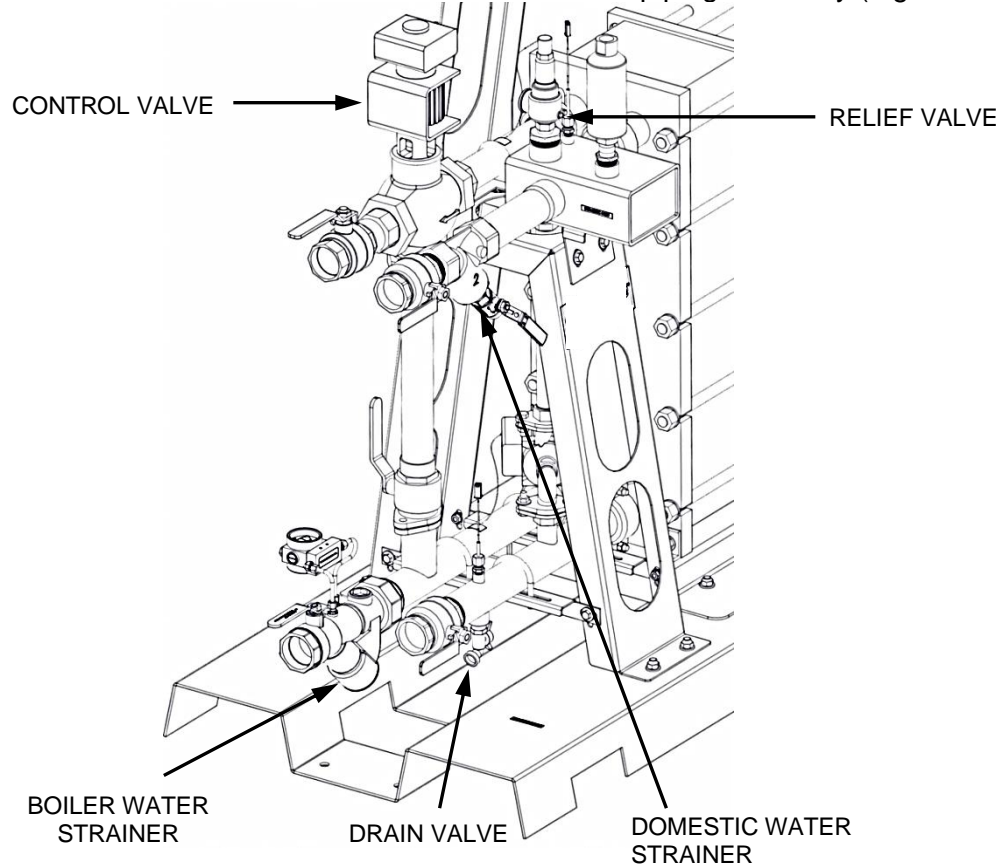

Figure 8-6. Draining the SmartPlate Double-Wall Water Heater

4. Open valve on the Strainer and drain the boiler water from the unit. It will be necessary to loosen a Victaulic coupling by the heat exchanger to allow air into the pipe during draining.
5. Next, connect a hose to the Drain Valve on the DHW Side of the piping assembly. Open the Relief Valve to allow air into the pipe during draining

HEAT EXCHANGER CLEANING BY DISASSEMBLY Instructions

6. Open the Drain Valve to drain the domestic water from the unit.
7. After the boiler water and domestic water have been drained from the unit, close the Relief Valve opened in step 5 and tighten the Victaulic coupling loosened in step 4.
8. To prevent possible damage, ensure that all of the following precautions are observed:
 - DO NOT use hydrochloric acid with stainless steel plates!
 - DO NOT use water of more than 300 ppm chlorine in cleaning solutions.
 - Make sure to protect all carrying bars and support columns against chemicals.
 - Do NOT use brushes with carbon steel bristles or steel wool. A fiber type brush is recommended. As a last resort, use a brush of similar material to the thermal plate. Be careful not to scratch the plates or damage gaskets if they are to be reused.
 - After brushing, rinse each plate with water.
 - For better sealing, wipe all gaskets dry.

CAUTION!

THE FOLLOWING SOLVENTS SHOULD NOT BE USED IN CONTACT WITH GASKETS:

- Ketones (e.g. Acetone, Methyletylketone, Methylisobutylketone)
- Esters (e.g. Ethyl acetate, Butyl acetate)
- Halogenated hydrocarbons (e.g. Chlorothene, Carbon Tetrachloride, Freons)
- Aromatics (e.g. Benzene, Toluene)

WARNING!

CARE MUST BE EXERCISED WHEN HANDLING CERTAIN FLUIDS. FOLLOW MANUFACTURER'S INSTRUCTIONS. USE EYE AND SKIN PROTECTION. WEAR A RESPIRATOR WHEN REQUIRED.

9. To open the Double-Wall heat exchanger and remove plates, refer to the procedures in sections 8.7.1 and 8.7.2.
10. Table 8-2 lists the recommended cleaning methods for the type of heat exchanger fouling encountered.

TABLE 8-2. Recommended Cleaning Procedures

TYPE OF FOULING	CAUSE	CLEANING METHOD	CHEMICAL CLEANING	NOTES
Incrustation Scaling (Lime Deposits)	Calcium Carbonate, Calcium Sulphate, Silicates	1. Soft brush & running water NOTE: Avoid Gasket Damage 2. High pressure hose. 3. Chemical cleaning	Nitric Acid Sulfamic Acid Citric Acid Phosphoric Acid Complex Agents (EDTA, NTA) Sodium Poly-phosphates	Maximum concentration: 4% Max. Temp: 140°F

HEAT EXCHANGER CLEANING BY DISASSEMBLY Instructions				
Sediment	Corrosion Products Metal Oxides Silt Alumina	<ol style="list-style-type: none"> Soft brush & running water NOTE: Avoid Gasket Damage High pressure hose. Chemical cleaning Addition of surfactants can improve cleaning effect 	Nitric Acid Sulfamic Acid Citric Acid Phosphoric Acid Complex Agents (EDTA, NTA) Sodium Poly-phosphates	Maximum concentration: 8% Max. Temp: 140°F
11. Upon completion of the cleaning process, reinstall all plates and gaskets and close the heat exchanger using the procedure in section 8.7.3.				

8.2.2 Double-Wall Heat Exchanger Opening And Closing

The following sections provide the instructions to open the Double-Wall heat exchanger, remove/replace channel plates and close the heat exchanger.

WARNING!
THE UNIT MUST BE SHUT DOWN AND DRAINED PRIOR TO PERFORMING THE PROCEDURES DESCRIBED IN SECTIONS 8.7.1 THROUGH 8.7.3 WHICH FOLLOW.

8.2.2.1 Opening Heat Exchanger

Perform the following steps to shut down, drain and open the Double-Wall Heat exchanger:

OPENING HEAT EXCHANGER Instructions
<ol style="list-style-type: none"> Ensure that the Water Heater has been shut down and drained using the procedures in section 8.6.1, steps 1 through 7. If the Heat exchanger is hot (over 100°F), allow it to cool sufficiently before proceeding. Remove the protective splash guard cover from the Double-Wall heat exchanger. Inspect sliding surfaces of the upper and lower support bars (Figure 8-7) and wipe clean.

OPENING HEAT EXCHANGER Instructions

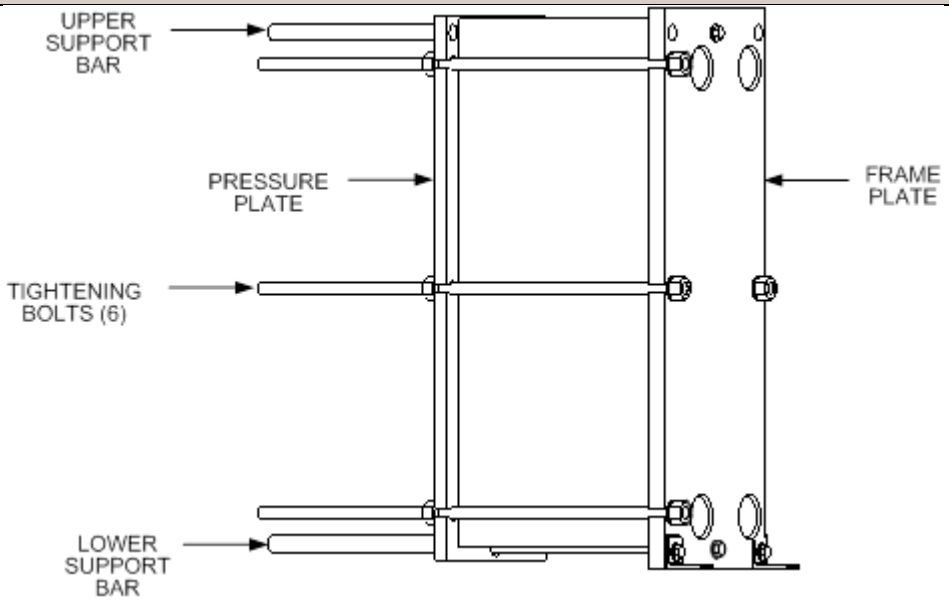

Figure 8-7. Double-Wall Heat Exchanger

5. Brush the threads of the tightening bolts clean using a steel wire brush.
6. Lubricate the threads of the tightening bolts with a thin layer of grease, such as molybdenum disulfide or equivalent.
7. Remove the protective splash guard to provide access to the plate pack assembly (see Figure 8-8, below).
8. Mark the plate pack assembly with a diagonal line as shown in Figure 8-8 or number the plates in sequence.

IMPORTANT!

Measurement of tightening dimensions is critical to reassembly. Carefully measure and record before loosening the tightening bolts.

9. Measure and record the lateral dimension "A" between the frame plate and pressure plate as shown in Figure 8-8.

OPENING HEAT EXCHANGER Instructions

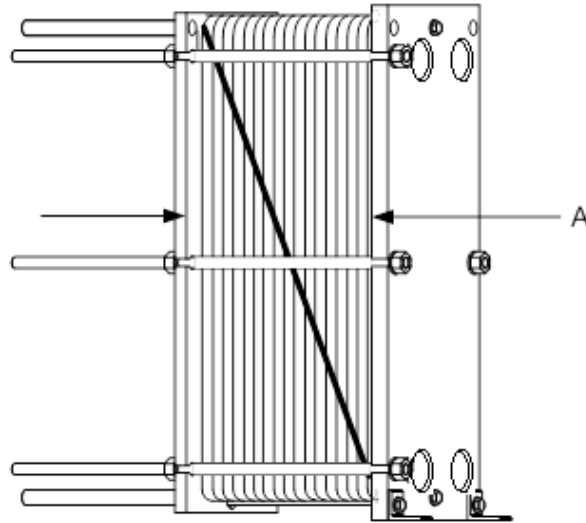

Figure 8-8. Measurement of Plate Pack Dimension "A" – Splash Guard Removed

10. If the unit is a model SPDW113, remove the U-bolt securing the heat exchanger support bar (see section 8.9 and Figure 8-18). If the unit is a model SPDW61, remove the U-bolt and "L" bracket at the rear of the heat exchanger mount to permit the pressure plate to be moved.
11. Opening of the heat exchanger is now possible by loosening diagonally-opposite pairs (Figure 8-9). Opening must be carried out evenly so that the pressure plate is not out-of-parallel with the frame plate by more than 3/8" (2 turns per bolt) in the horizontal plane and 1" in the vertical plane.

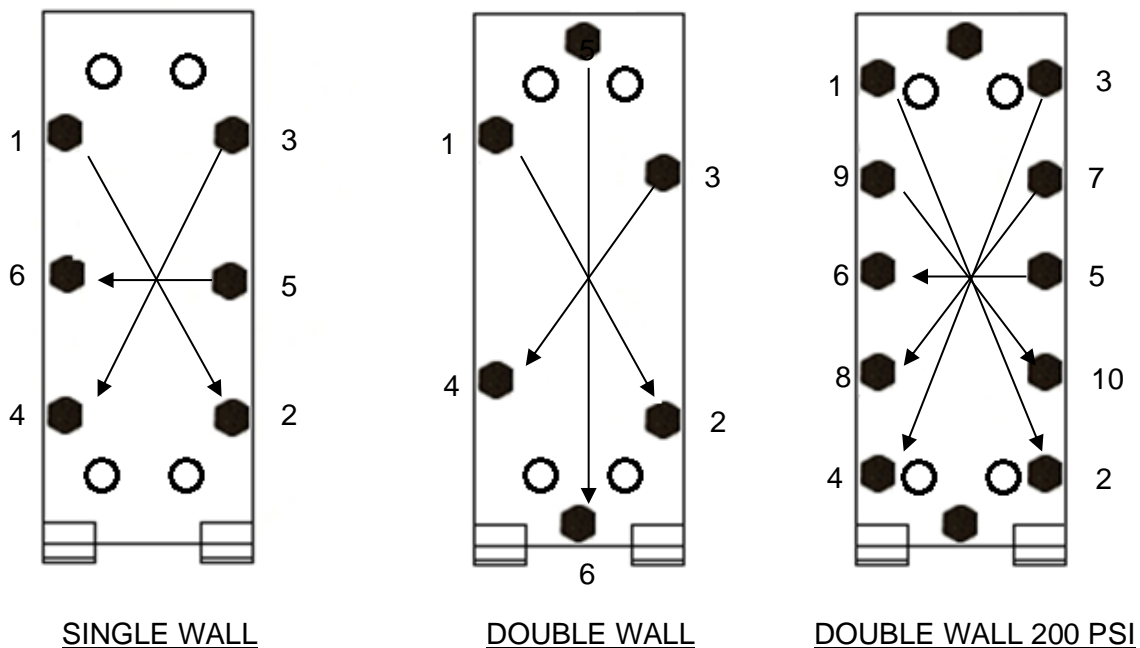

Figure 8-9. Required Bolt Loosening Pattern

OPENING HEAT EXCHANGER Instructions

12. With the tightening bolts removed, the pressure plate can be slid back (Figure 8-10) and channel heat transfer plates can also be slid back for inspection or cleaning.

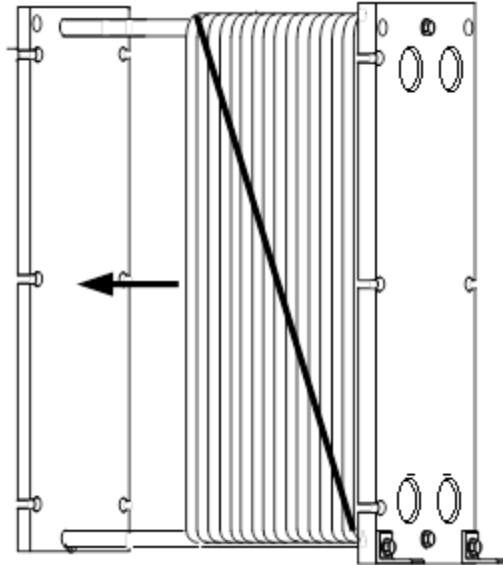

Figure 8-10. Heat Exchanger with Pressure Plate Slid Back

8.2.2.2 REMOVAL AND INSERTION OF PLATES

To remove and insert the channel (heat transfer plates), proceed as follows:

WARNING!

USE PROTECTIVE GLOVES TO AVOID HAND INJURIES WHEN HANDLING PLATES.

NOTE: If defective gaskets are detected during removal of plates, they must be replaced using the procedures in section 8.8.

REMOVAL AND INSERTION OF PLATES Instructions

1. Push the pressure plate back away from the plate pack.
2. When removing the plates, number or stack them in sequence.
3. Hang the plates with their backs towards the pressure plate (the side without gasket), unless otherwise specified.
4. Always consult the plate pack numbering or markings to insure the proper plate sequence.
5. Install plates one at a time and push them towards the frame plate (Figure 8-11).

REMOVAL AND INSERTION OF PLATES Instructions

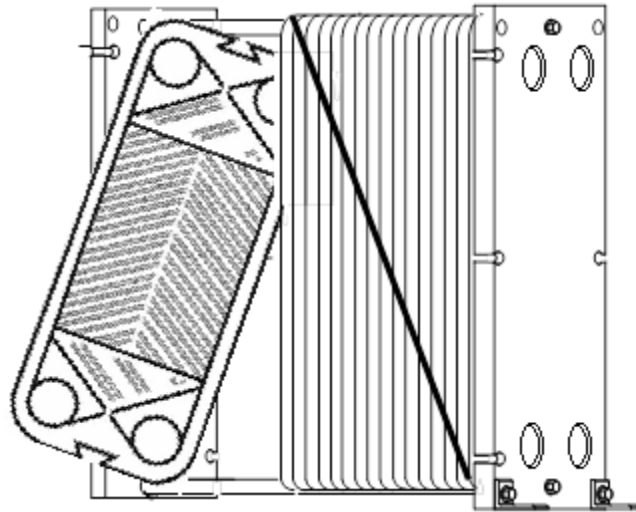

Figure 8-11. Insertion of Plates in Heat Exchanger

8.2.3 Closing Heat Exchanger

Closing the heat exchanger is accomplished as follows:

CLOSING HEAT EXCHANGER Instructions

1. Check that all sealing surfaces in contact with the heat transfer medium are clean.
2. Check that connection fittings are in position and are in good condition.
3. Clean and lubricate the sliding surfaces of the upper and lower support bars.
4. If plates are correctly assembled, the edges form a "honey comb" pattern as shown below.

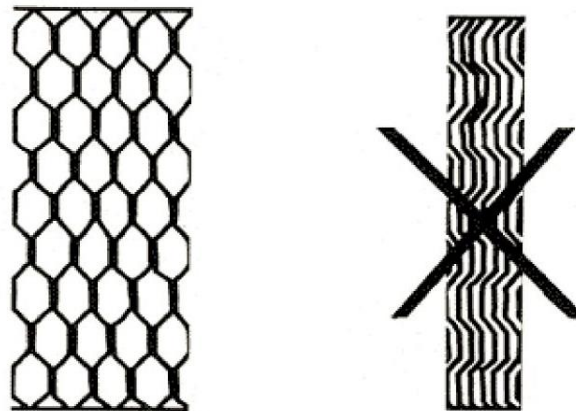

Figure 8-12. Heat Exchanger Plates

5. Slide the pressure plate forward and press the plates together (Figure 8-13). If the plate pack was previously marked on the outside (Figure 8-8), check to ensure that the plate arrangement agrees with the markings.

CLOSING HEAT EXCHANGER Instructions

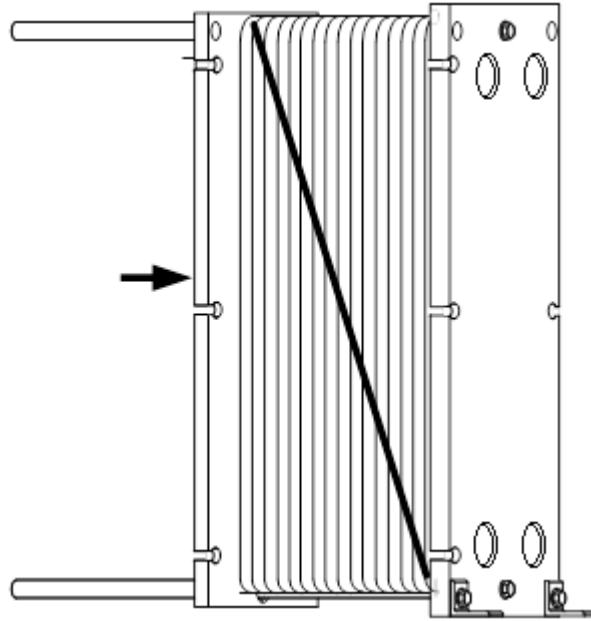

Figure 8-13. Closing the Heat Exchanger

6. Brush the threads of the bolts clean, using a steel wire brush.
7. Lubricate the threads with a thin layer of grease.
8. Place bolts in position and tighten the plate pack using diagonally opposite bolt pairs, (the opposite of the opening procedure in section 8.7.1, step 10) until the plate pack length is reduced to $\pm 1\%$ of dimension "A" in the channel plate assembly instructions supplied with unit. During tightening. The pressure plate must not be out-of-parallel to the frame plate by more than $3/8$ " in the horizontal plane and 1" in the vertical plane. See Figure 8-14.

CLOSING HEAT EXCHANGER Instructions

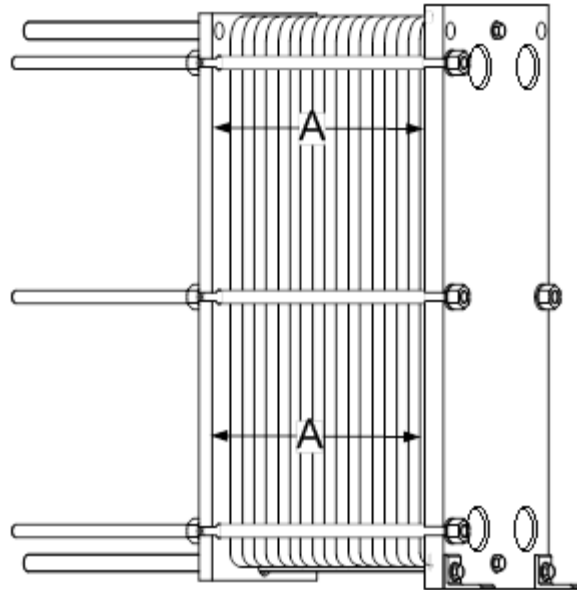

Figure 8-14. Tightening Plate Pack Bolts

9. Check the plate pack length ("A") during closing in at least four locations close to the bolts being used.
10. Place the remaining bolts in position and tighten them.
11. Next, insert the corner bolts and tighten, maintaining dimension "A" of drawing- To avoid damaging the channel plate corners, it is important that the corner bolts are not used for closing the heat exchanger.
12. The nominal plate pack length "A" can be exceeded in some cases. The tightening can be stopped at "A" + 2% and pressure tested.

NOTE: When a pneumatic tightening device is used, it should be set at the maximum tightening torque of 550 ft-lbs for DW for 3/4" bolts.

Dimension "A" must, however, must still be measured during tightening.

When the bolts are tightened by hand using a wrench, the tightening moment is estimated.

IF DIMENSION "A" IS NOT REACHED WITH APPLICATION OF MAXIMUM TIGHTENING TORQUE:

- Check the number of plates and dimension "A".
- Check that all nuts are running freely. If not, clean and lubricate or replace.
- Fit all bolts and tighten alternately.

13. Perform the following final checks:

- a) Inspect the washers.
- b) When fully tightened. The bolts should all be equally tensioned
- c) The difference between the plate pack lengths measured at adjacent bolts should not exceed: 0.079 inches.

CLOSING HEAT EXCHANGER Instructions

- d) The plate pack length at all bolts must not differ more than 1%.
 - e) If the unit does not seal fully, it can be tightened to give dimension "A" - 1%. However, the maximum tightening torque must not be exceeded.
14. Install the protective splash guard.

8.2.4 Double-Wall Heat Exchanger Gasket Replacement

All sizes of the Double-Wall heat exchanger utilize "Clip-Type" glueless gaskets. The following sections provide the instructions to replace gaskets on channel plates and on the end plate (first plate against frame plate)

Refer to the appropriate procedures in sections 8.7.1 and 8.7.2 to open the heat exchanger and remove the required plates. Following gasket replacement, close the heat exchanger using the procedures in section 8.7.3.

8.2.4.1 Replacing Gaskets on Channel Plates

Replacing Gaskets on Channel Plates Instructions

1. Peel old gasket off of plate making sure all parts of gasket are removed.
2. Wipe gasket groove clean making certain that no foreign material remains that would cause gasket to seat unevenly.
3. Clip-type glueless gaskets (Figure 8-15) are attached to the plate using the prongs which slip under the edge of the plate to hold the gasket securely in the gasket groove. The prongs are situated at regular intervals around the perimeter of the plate.

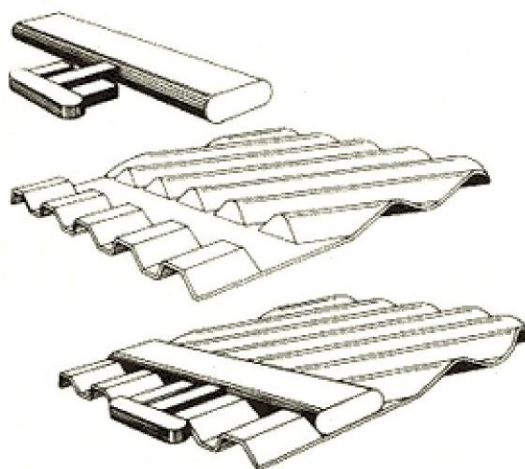

Figure 8-15. Clip-Type Glueless Gasket Installation

4. When the plates of the heat exchanger are assembled and tightened, the gasket provides a tight seal around the plate.
5. Before closing plate pack ensure gasket prongs are in correct position.

8.2.4.2 Replacing Gaskets on End Plate (First Plate Against Frame Plate)

Replacing Gaskets on End Plate Instructions

1. Obtain two standard plate gaskets (P/N **81128** for DW units).
2. Cut the gaskets as indicated in Figure 8-16, below.
3. Attach gasket to plate as indicated in Figure 8-17, below.

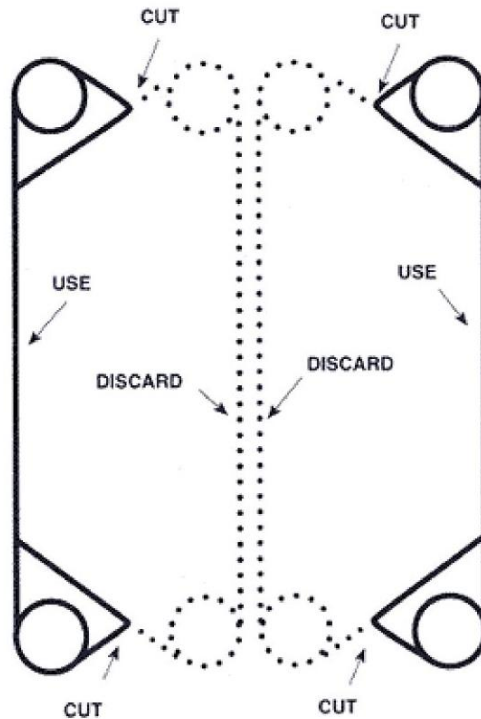

Figure 8-16. Cutting Gaskets For End Plate

Replacing Gaskets on End Plate Instructions

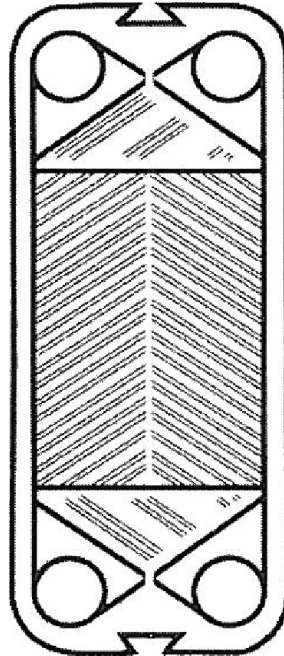

Figure 8-17. End Plate with Gasket Installed

8.2.5 Double-Wall Heat Exchanger Replacement

The heat exchanger used in each SmartPlate Double-Wall model is removed and replaced using the following basic procedure:

DOUBLE-WALL HEAT EXCHANGER REPLACEMENT Instructions

1. Turn OFF the POWER Switch on the side of the ECS/SP Control Box.
2. Slowly close all four of the Isolation Ball Valves (Figure 8-5).
3. Connect a hose to the Strainer on the Boiler Water side of the piping assembly (Figure 8-6). Open the valve on the Strainer and drain the boiler water from the unit. It will be necessary to loosen a Victaulic coupling by the heat exchanger to allow air into the pipe during draining.
4. Next, connect a hose the Drain Valve on the DHW Side of the piping assembly. Open the Relief Valve to allow air into the pipe during draining.
5. After the boiler water and domestic water have been drained from the unit, close the Relief Valve opened in step 4 and proceed to step 6 to remove the installed heat exchanger.
6. Using a ratchet wrench with an extension and a 3/4" deep socket, remove, the four (4) Victaulic couplings (Figure 8-19). Two (2) couplings are located on the Domestic Water Side and two (2) are located on the Boiler Water Side.
7. Next, remove the two (2) bolts securing the front "L" brackets on the heat exchanger to the heat exchanger mount (Figure 8-18).

DOUBLE-WALL HEAT EXCHANGER REPLACEMENT Instructions

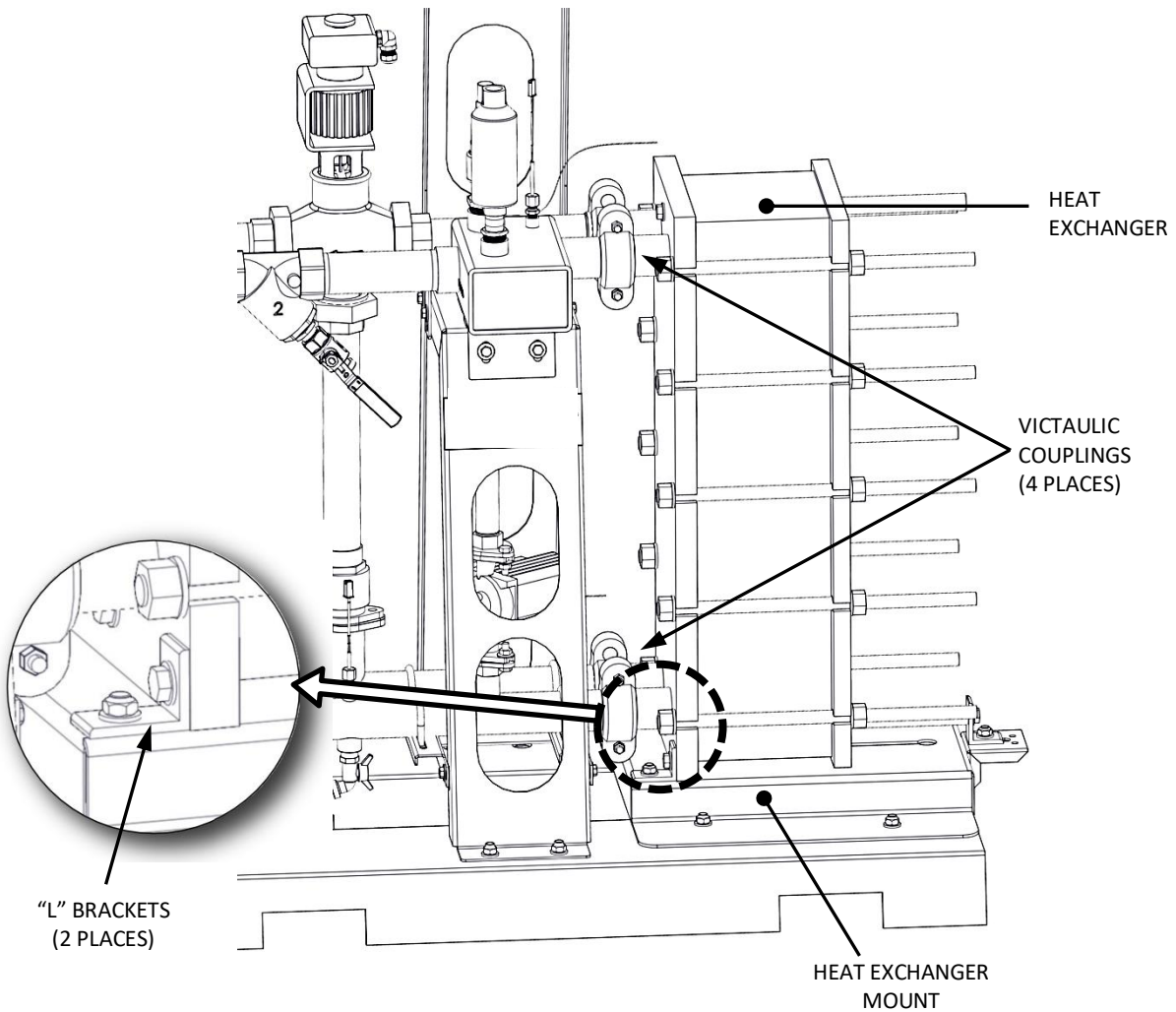

Figure 8-18. Domestic Water Side - Double-Wall Partial View

8. For larger SmartPlate units (models SPDW61, SPDW113) remove the U-bolt securing the heat exchanger support bar (not shown above) and, if there is an "L" bracket, remove it.
9. For smaller SmartPlate units (models SPDW23, SPDW32 SPDW42) use a 3/4" socket wrench to remove the horizontal hex head screw and washer shown in Figure 8-19. Also, remove the hex nut securing the "L" bracket to the heat exchanger mount.

DOUBLE-WALL HEAT EXCHANGER REPLACEMENT Instructions

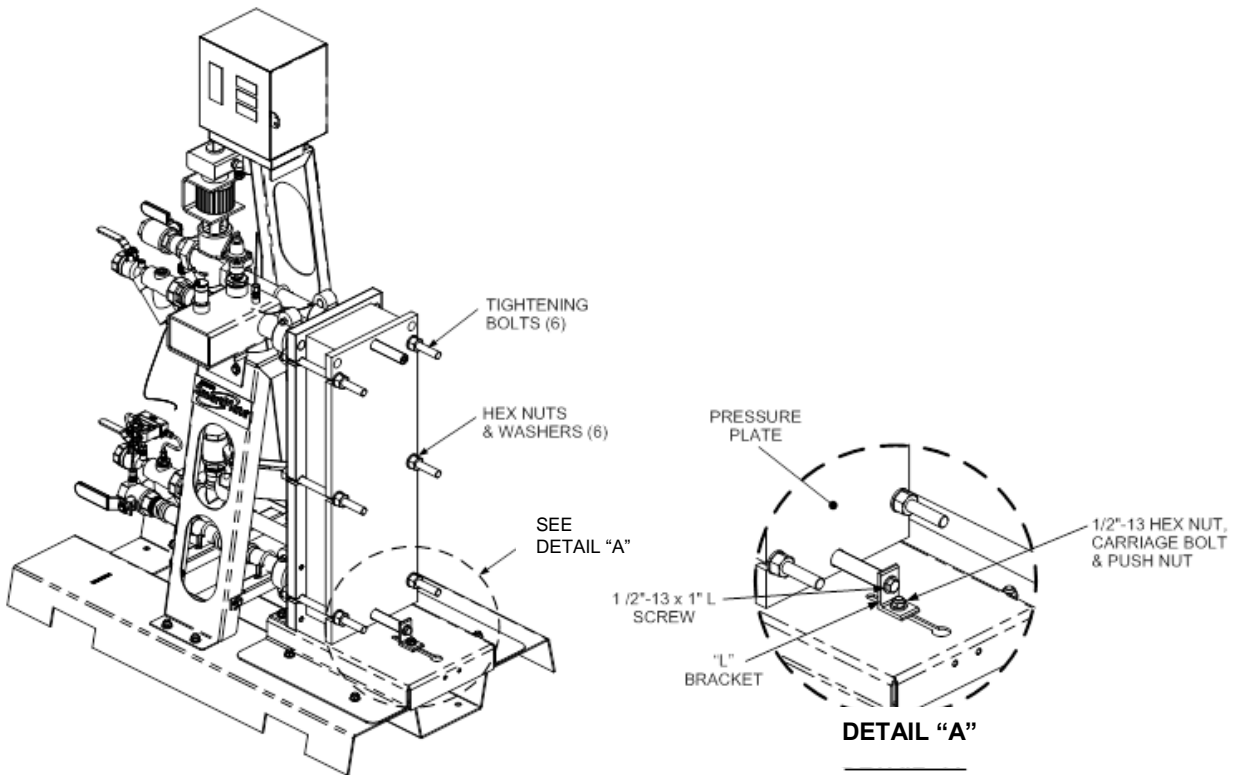

Figure 8-19. Double-Wall Heat Exchanger Mounting Details - Rear

WARNING!

DEPENDING ON THE SMARTPLATE MODEL, THE DOUBLE-WALL HEAT EXCHANGER WEIGHS **BETWEEN 350 AND 800 POUNDS**. YOU MUST THEREFORE USE EXTREME CARE WHEN REMOVING THE HEAT EXCHANGER FROM ITS MOUNT. USE A STRAP SUITABLE FOR SUCH WEIGHT TO LIFT AND REMOVE THE HEAT EXCHANGER FROM ITS MOUNT.

10. Insert a lifting strap through the four (4) holes in the frame plate and pressure plate, as shown in Figure 8-20, to safely lift the heat exchanger off its mount. You may also wrap the lifting strap around the threaded bolts instead of through the holes in the Pressure Plate.

DOUBLE-WALL HEAT EXCHANGER REPLACEMENT Instructions

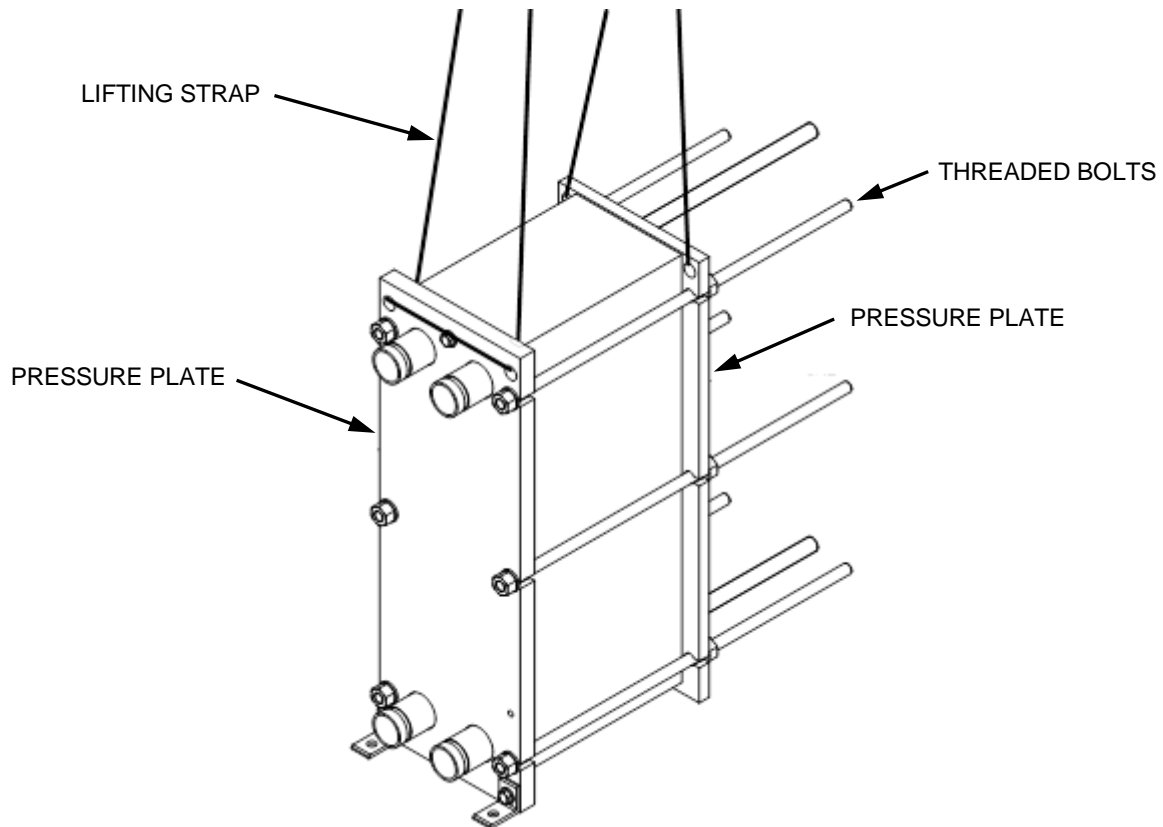

Figure 8-20. Heat Exchanger Lifting Strap

To replace the heat exchanger with a new assembly, simply reverse the previous steps. Support the replacement heat exchanger using a suitable lifting strap (shown in Figure 8-20, above) and lower into position on the heat exchanger mount. Ensure it is properly aligned with the Piping Assembly and heat exchanger mount. Ensure that the bolts on all four Victaulic couplings or flange connectors are securely tightened. For model SPDW61 or SPDW113, re-install the rear support bracket and verify that adjustable legs are properly positioned.

8.3 Smartplate Wetted Components - All Models

8.3.1 Control Valve Electronic Module Replacement And Valve Removal

The only replaceable item on the 3-Way Control Valve (Siemens MXG-461) is the Electronics Module located at the top of the Valve (Figure 8-21). The procedures for removing this Module or replacing the complete Control Valve are provided in sections 8.10.1 and 8.10.2, below.

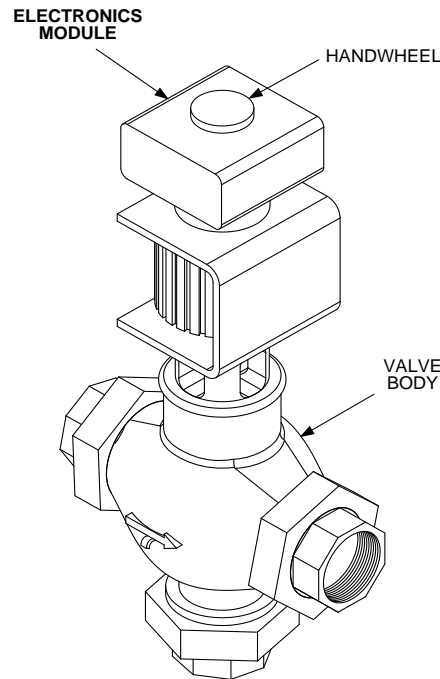

Figure 8-21. Control Valve (Siemens MXG-461)

8.3.1.1 Electronics Module Replacement

To remove and replace the Control Valve Electronics Module:

1. Turn OFF the POWER Switch on the side of the ECS/SP Control Box.
2. Loosen the two (2) captive screws securing the Electronics Module cover (Figure 8-22).
3. Remove the Module cover to access the wiring terminals (Figure 8-23). Disconnect and tag the power and control signal wire leads from the Module terminals.
4. Using a 3 mm Allen key, loosen the three (3) socket head screws securing the blue Electronics Module to the black Valve Head. These screws are recessed and the Allen key must be inserted into the holes shown in Figure 8-23 to engage the screw heads.
5. Pull straight up to unplug the Module from the Valve Head.
6. Install the replacement Electronics Module on the Valve Head and secure it with the three socket head screws removed in step 4.
7. Refer to Figure 8-23 and ensure that the three (3) DIP switches on the replacement Module are all in the OFF (down) position.
8. Reconnect the power and control signal wire leads to the Electronics Module.

To remove and replace the Control Valve Electronics Module:

9. Turn ON the POWER Switch on the side of the ECS/SP Control Box.
10. Recalibrate the Control Valve using the procedures in Chapter 4, section 4.2.1.
11. Replace the cover on the Electronics Module after the Valve has been successfully calibrated.
12. Return the unit to service.

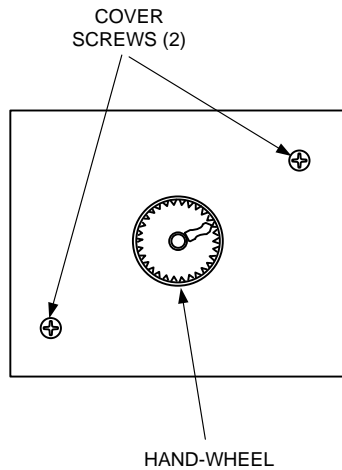

Figure 8-22. Control Valve Electronics Module Cover – Top View

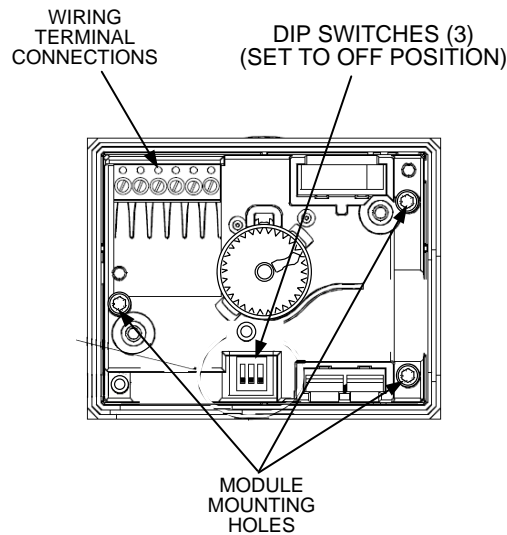

Figure 8-23. Electronics Module with Cover Removed

8.3.1.2 Control Valve Replacement

To remove the complete Control Valve Assembly from the SmartPlate Water Heater:

1. Turn the POWER Switch on the side of the ECS/SP Control Box to **OFF**.
2. Loosen the two (2) captive screws securing the Electronics Module cover (Figure 8-22).
3. Remove the Module cover to access the wiring terminals (Figure 8-23). Disconnect and tag the power and control signal wire leads from the Module terminals.
4. Connect a hose to the Blow-Down Valve/Drain on the lower pipe Strainer (Figure 8-24).
5. Close both Isolation Ball Valves on the Boiler Water pipe side of the unit.
6. Open the Blow-Down/Drain Valve on the Strainer.

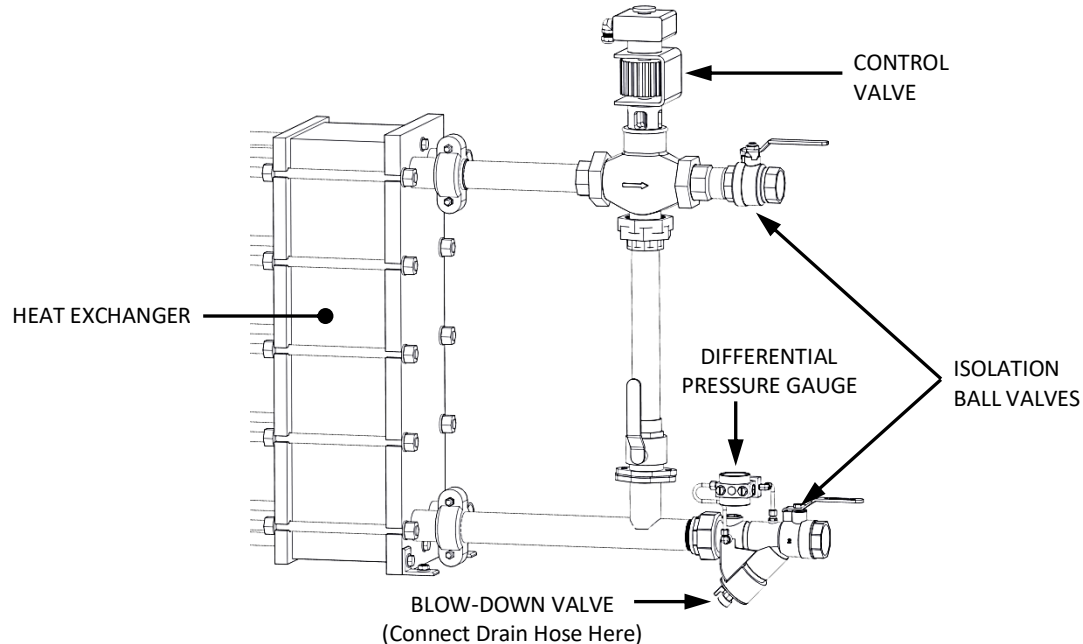

Figure 8-24. Boiler Water Piping Components

7. While supporting Control Valve from above, loosen all three (3) unions securing the Valve.
8. Inspect the union seals and seats.
9. Install the replacement Control Valve and ensure that the seals are not pinched. Hand-tighten the unions. **NOTE:** Two (2) pipe wrenches **MUST** be used when tightening the Valve unions to prevent pipe rotation and avoid leaks
10. Using two (2) pipe wrenches, secure the Control Valve unions to the Boiler Water piping.
11. Refer to Figure 8-23 and ensure that the three (3) DIP switches on the Electronics Module of the replacement Valve are all in the OFF (down) position.
12. Reconnect the power and control signal wire leads to the Electronics Module of the replacement Control Valve.
13. Turn **ON** the POWER Switch on the side of the ECS/SP Control Box.
14. Recalibrate the Control Valve using the procedures in Chapter 4, section 4.2.1.
15. Replace cover on the Electronics Module after the Valve is successfully calibrated.
16. Return the unit to service.

8.3.2 Recirculation Pump Replacement

The SmartPlate Recirculation Pump is a wet rotor, continuous-duty Pump which has an expected service life of 5 years. The Pump is located in the DHW side of the piping assembly (Figure 8-25) to continuously circulate domestic water through the unit, even when there is no DHW demand. If the Pump fails, it must be replaced to ensure proper Water Heater operation. Replacement is accomplished as follows:

RECIRCULATION PUMP REPLACEMENT Instructions

1. Turn **OFF** the external power circuit breaker to the Water Heater and also turn **OFF** the POWER Switch on the side of the ECS/SP Control Box.
2. Connect a hose to the DHW Drain Valve (Figure 8-25).
3. Close both Isolation Ball Valves on the DHW piping.
4. Open the DHW Drain Valve.
5. Open the Relief Valve to allow air to enter the piping while draining.
6. Disconnect the power leads from the Pump Head.
7. Remove the bolts on the Pump flanges and slide the Pump out from between the flanges.
8. When installing the replacement Recirculation Pump, ensure that the seals are in place and are not pinched.
9. Reinstall the flange bolts and reconnect the power leads to the Pump Head.
10. Close the Relief Valve opened in step 5.
11. Close the DHW Drain Valve that was opened in step 4.
12. Connect a hose to the Blow-Down Valve on the Inlet Strainer. Open this Blow-Down Valve on the Strainer to vent air during the filling process.
13. Open the lower Isolation Ball Valve (DHW Outlet).
14. Next, close the Blow-Down Valve on the Inlet Strainer and open the upper Isolation Ball Valve (DHW Inlet).
15. Reconnect the power leads to replacement Recirculation Pump Head.
16. Turn ON the external circuit breaker and set the POWER Switch on the side of the ECS/SP Control Box to the ON position to return the unit to service use.

RECIRCULATION PUMP REPLACEMENT Instructions

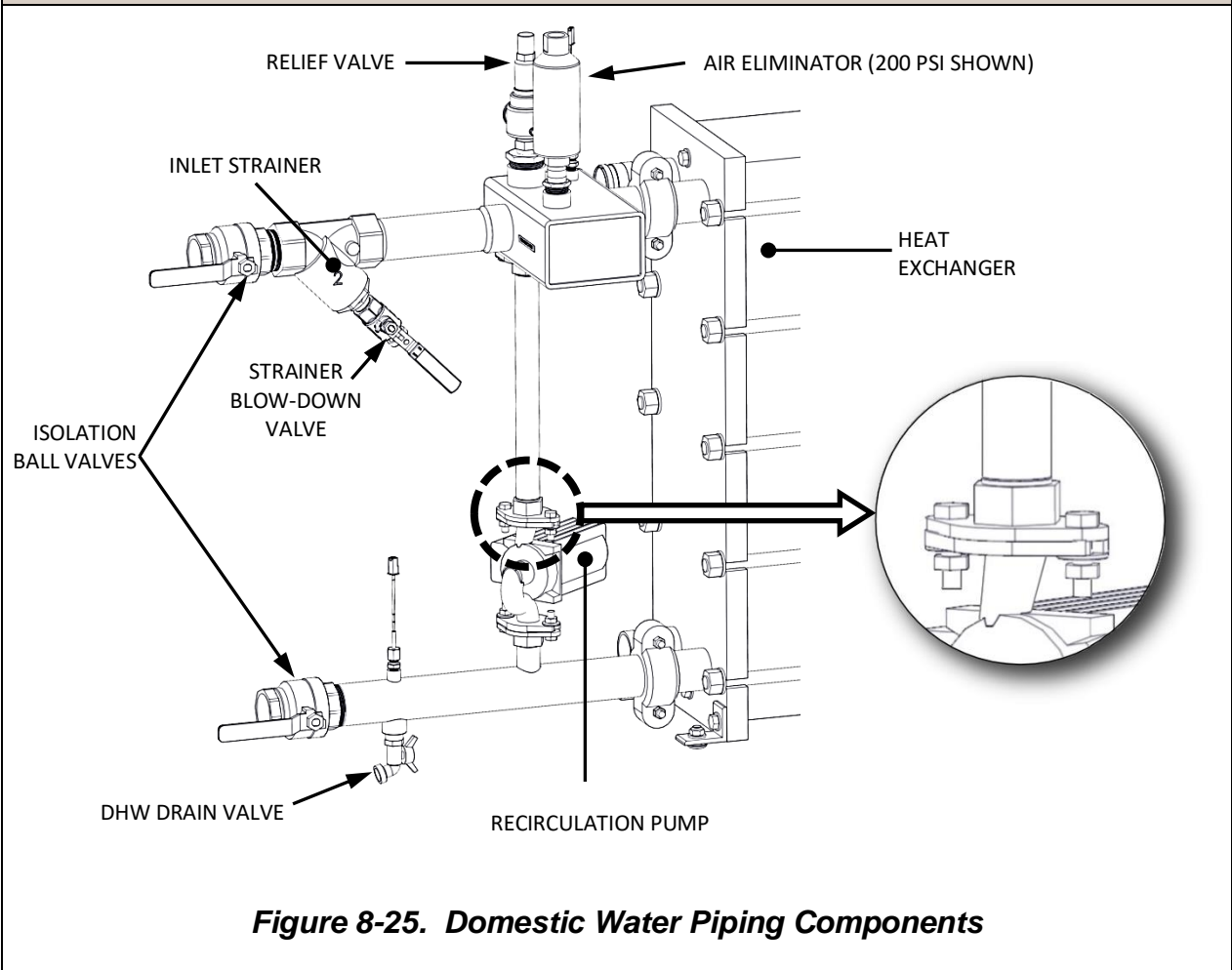

Figure 8-25. Domestic Water Piping Components

8.3.3 Strainers

All SmartPlate Water Heater models utilize Combination Strainers and Ball Valve on the boiler side, and a strainer on the DHW side to prevent fouling of the heat exchanger by trapping foreign material before it enters the unit. In addition, SmartPlate provides a Differential Pressure Gauge on the Boiler Water Inlet to aid in determining when to blow-down the Strainer. If this Gauge becomes inoperable, it should be replaced using the following procedure.

NOTE: If normal maintenance does not clear the Water Heater flow path, it will be necessary to remove and manually clean the screens in the Boiler Water and DHW piping as follows:

- a. Remove Strainer end cap and remove screen.
- b. Hose and wash off screen.
- c. Reinstall screen and replace Strainer end cap.

DIFFERENTIAL PRESSURE GAUGE REPLACEMENT Instructions

1. Close both Isolation Ball Valves in the Boiler Water piping (Figure 8-24).
2. Connect a hose to the Blow-Down/Drain Valve at the lower Strainer and open it to drain the piping. It may be necessary to temporarily loosen a union on the Control Valve to allow air into the piping.
3. Refer to Figure 8-26 and loosen the two compression fitting nuts on the Differential Pressure Gauge tubes which are inserted into the brass Strainer body.
4. Pull and wiggle the tubes and Gauge and lift the assembly straight upward to remove it from the Strainer.
5. Next, loosen the nuts on the Gauge body fittings and extract the tubes for use on the replacement Differential Pressure Gauge.

NOTE: The tube fittings are pass-thru type fittings that allow the tube to slide through the fitting without hitting a stop. Prior to installation, make sure that the replacement Gauge has the same type of fittings.

6. Install the tubes on the replacement Differential Pressure Gauge.
7. Insert the free ends of the tubes into the Strainer body and tighten the compression fittings. DO NOT over-tighten the compression fittings.
8. Tighten the Control Valve union that was loosened in step 2.
9. Close the Blow-Down Drain Valve and open both Isolation Ball Valves (Figure 8-24).
10. Place the unit back in service and check for leaks. If the Strainer is clean and the flow is within specification for the SmartPlate Water Heater model, the pointer on the Differential Pressure Gauge should be in the Green zone on the dial.

DIFFERENTIAL PRESSURE GAUGE REPLACEMENT Instructions

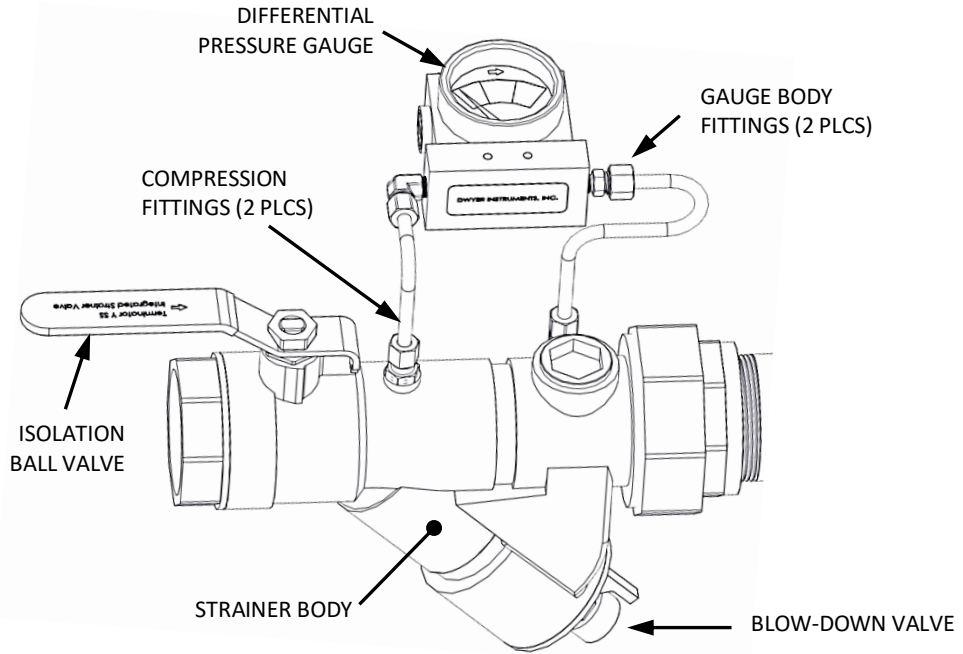

Figure 8-26. Differential Pressure Gauge/Strainer/Ball Valve Combo – Boiler Side

8.4 Smartplate Electronic Control System (Ecs/Sp)

WARNING!

TURN OFF THE CONTROL BOX POWER SWITCH AND DISCONNECT AC POWER PRIOR TO PERFORMING ANY CORRECTIVE MAINTENANCE PROCEDURES IN THE FOLLOWING SECTIONS. FAILURE TO OBSERVE THIS WARNING MAY RESULT IN SERIOUS PERSONAL INJURY.

8.4.1 Ecs/Sp Control Box Assembly And Components

Corrective maintenance for the Control Box and internally-mounted components consist of removing and replacing the following items:

- Control Box Assembly
- Temperature Controller
- Over-Temperature Switch
- Temperature Indicators
- 24 VAC Step-Down Transformer

The following sections reference figures in previous chapters as well as in this chapter. Refer to the applicable figures as necessary when performing the replacement procedures which follow.

8.4.2 Control Box Assembly Replacement

If necessary, the complete ECS/SP Control Box Assembly can be removed and replaced as follows:

CONTROL BOX ASSEMBLY REPLACEMENT Instructions

1. Loosen captive screws on the Control Box door and the recessed panel (Figures 2-3, 2-4).
2. Open the swing-down recessed panel. Locate and disconnect the Line, Neutral and Ground leads connected to Terminal Block TB-2 on the bottom interior surface of the Control Box chassis (Figure 2-5).
3. Refer to Figures 1-1 and 1-2 and disconnect the Control Box cables from the following devices:
 - a) Disconnect Control Valve (Siemens MXG-461) power and leads from strip TB-1.
 - b) Disconnect the external AC power leads from terminal strip TB-2.
 - c) Disconnect the Recirculation Pump power leads from terminal strip TB-2.
 - d) Disconnect the Mixed Inlet Temp cable from the Mixed Inlet Temp Sensor on the top of the unit's Mixing Box.
 - e) Disconnect the Hot Water Outlet Temp cable from the Dual Outlet Temp Sensor at the unit's DHW outlet.
 - f) Disconnect BOILER TC IN and TC OUT leads (2-pin Molex connectors) connected to the heating fluid (boiler water) inlet and outlet Temperature Sensors.
4. After all Control Box cables have been disconnected, remove the four mounting screws securing the bottom of the Control Box to the mounting bracket. Completely remove the Control Box from the unit.
5. Control Box replacement is accomplished by reversing the previous steps.

8.4.3 Temperature Controller Replacement

The Temperature Controller is located on the recessed panel behind the Control Box door as shown in Figure 4-4. Removal and replacement is accomplished as follows:

TEMPERATURE CONTROLLER REPLACEMENT Instructions

1. Switch power off and open the Control Box door to access the Temperature Controller.
2. The Temperature Controller is installed in a sleeve as shown in Figure 8-27. To unplug and remove the Controller from its sleeve, simply pry the latching ears outward and pull the Controller out of the panel.
3. To install a replacement Temperature Controller, simply slide it into the front panel sleeve until the latching ears click into place. Following replacement, switch power on adjust the setpoint temperature to the required value using the Adjustment procedures in Chapter 4.
4. Close and secure Control Box front door.

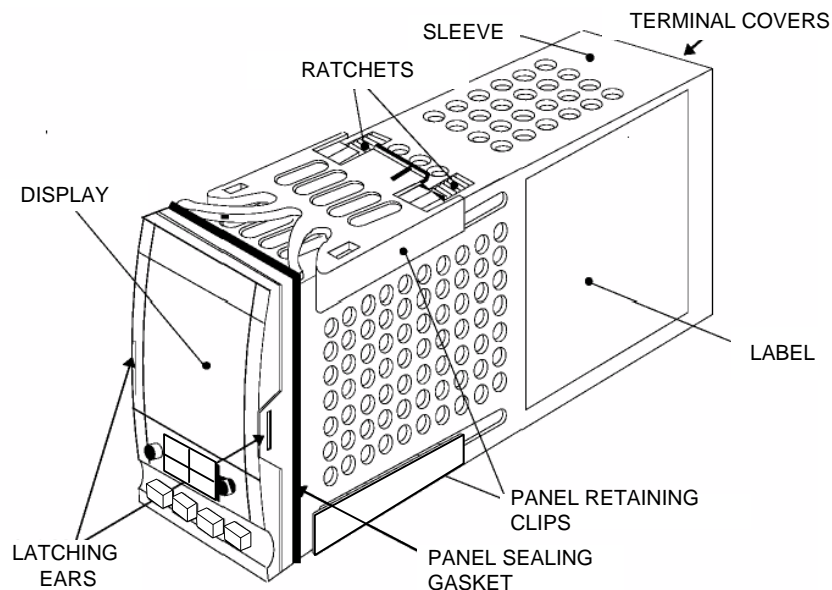

Figure 8-27. Temperature Controller Installation

8.4.4 Over-Temperature Switch And Temperature Indicators

The Over-Temperature Switch and Temperature Indicators are actually identical devices, however they perform different functions. As the name implies, the Over-Temperature Switch, performs a switching function and generates an alarm when the preset temperature limit is exceeded. However, the Temperature Indicators are Indicator-Only devices and are not factory wired to perform any switching functions. The locations of the Over-Temperature Switch and Temperature Indicator are shown in Figure 4-4. Removal and replacement for each device are performed using the following identical steps:



Figure 8-28. Over-Temperature Switch & Temperature Indicator

Over-Temperature Switch and Temperature Indicator Replacement Instructions

1. Open the Control Box door to locate the Switch or Indicator to be replaced.
2. Loosen the captive screw on the recessed panel behind the door. Open the swing-down panel to access the Switch/Indicator wiring connections and panel retaining clips.
3. Remove the Switch/Indicator rear cover and loosen the terminal wiring connection screws. Disconnect the wires.
4. To remove the Over-temperature Switch assembly, push in tab of each of two side retaining clips (Figure 8-29), slide toward rear and remove.
5. Insert the replacement Over-Temperature Switch or Temperature Indicator into the panel cutout.
6. Slide the removable retaining clip onto the replacement Switch/Indicator from the rear. Push the retaining clip forward until the Switch/Indicator is firmly secured in the panel cutout.
7. Reconnect the wiring to the rear of the unit and tighten the terminal screws. Replace the terminal cover.

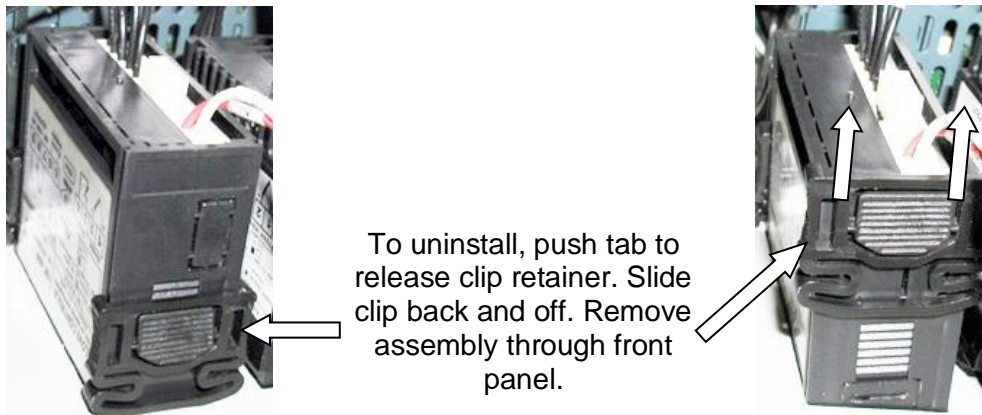

Figure 8-29. Removing Over-Temperature Switch Assembly

8. If the replaced unit is an Over-Temperature switch, set the desired over-temperature alarm limit using the adjustment procedures in Chapter 4, section 4.2.4.
9. Following adjustment (if necessary), raise and secure the swing-down panel. Close and secure the Control Box door.

8.4.5 24 Vac Step-Down Transformer Replacement

The 24 VAC Transformer is mounted on the back interior wall of the Control Box (Figure 8-30, View D-D). Replacement is accomplished as follows:

STEP-DOWN TRANSFORMER REPLACEMENT Instructions

1. Open Control Box door and loosen captive screw on recessed panel behind the door.
2. Open the swing-down panel and locate the 24 VAC Transformer on the back interior wall of the Control Box (Figure 8-30, sheet 2).
3. Disconnect the Transformer wire leads from terminal strips TB-1 and TB-2.
4. Remove the mounting hardware and 24 VAC Transformer from the Control Box.
5. Replacement is accomplished by reversing the previous steps.

STEP-DOWN TRANSFORMER REPLACEMENT Instructions

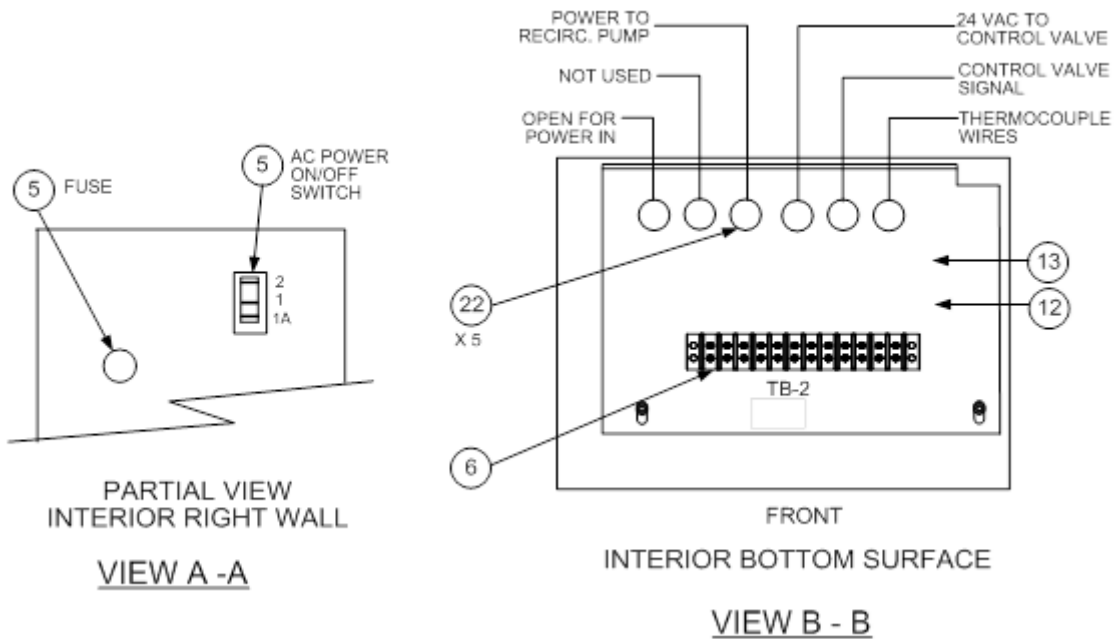
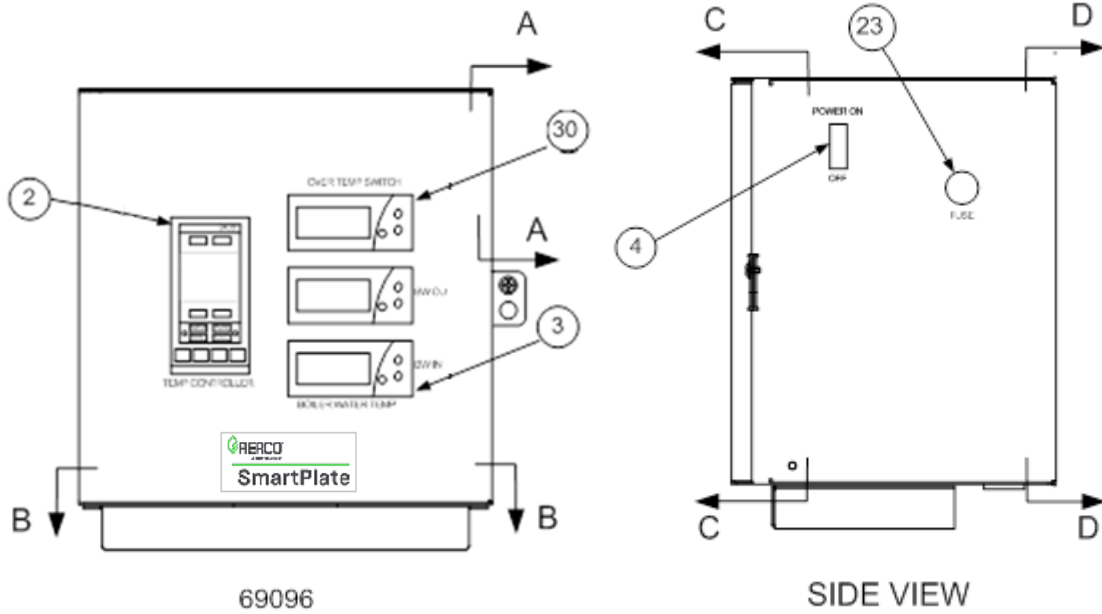

Figure 8-30. ECS/SP Control Box Assembly 69096 (Sheet 1 of 2)

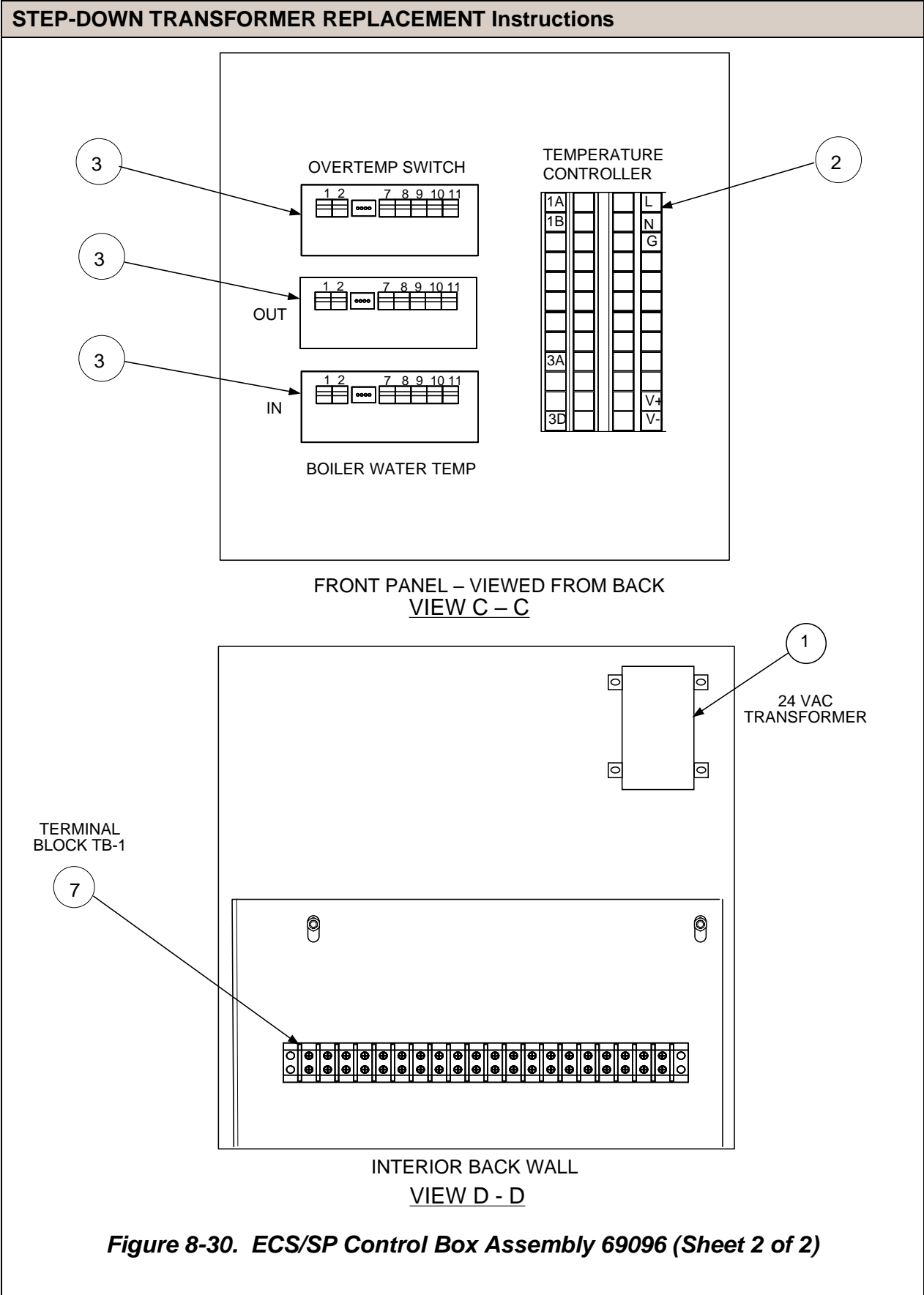

Figure 8-30. ECS/SP Control Box Assembly 69096 (Sheet 2 of 2)

STEP-DOWN TRANSFORMER REPLACEMENT Instructions

ECS/SP CONTROL BOX ASSEMBLY 69096 PARTS LIST





Item	Qty.	Part No.	Description
1	1	65082	TRANSFORMER, X075CBA, 120/240 TO 24 VAC
2	1	64008	TEMPERATURE INDICATOR CONTROLLER
3	2	64056	OVER-TEMP SWITCH/TEMP INDICATOR
4	3	60003	ON/OFF SWITCH
6	1	65087	TERMINAL BLOCK, 12-POSITION (TB-2)
7	1	65008	TERMINAL BLOCK, 20-POSITION (TB-1)
12	1	63047	AC WIRE HARNESS
13	1	63048	CONTROL WIRING HARNESS
15	1	63009-3	EXTERNAL HARNESS
22	5	62003	PLUG
23	1	65094-1	FUSE
30	1	60014	OVER-TEMPERATURE SWITCH

(This page left intentionally blank)

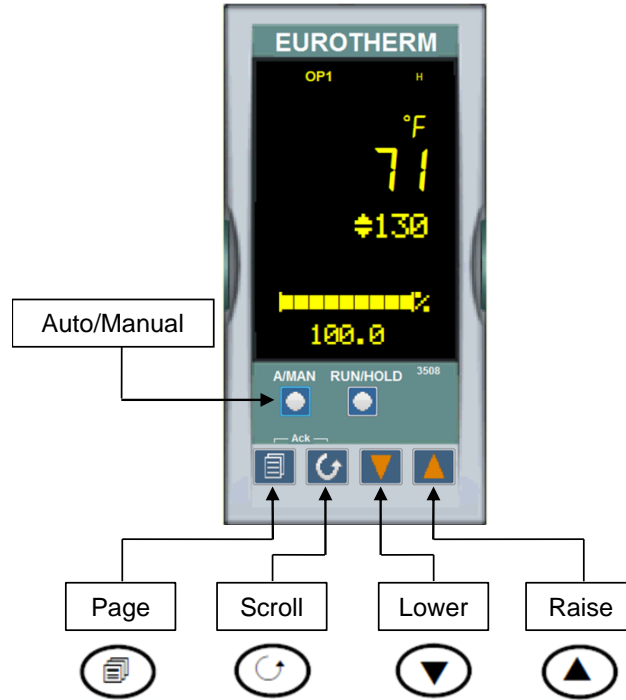
APPENDIX A – EUROTHERM 3508 CONTROLLER OPERATION

A.1 Operator Buttons



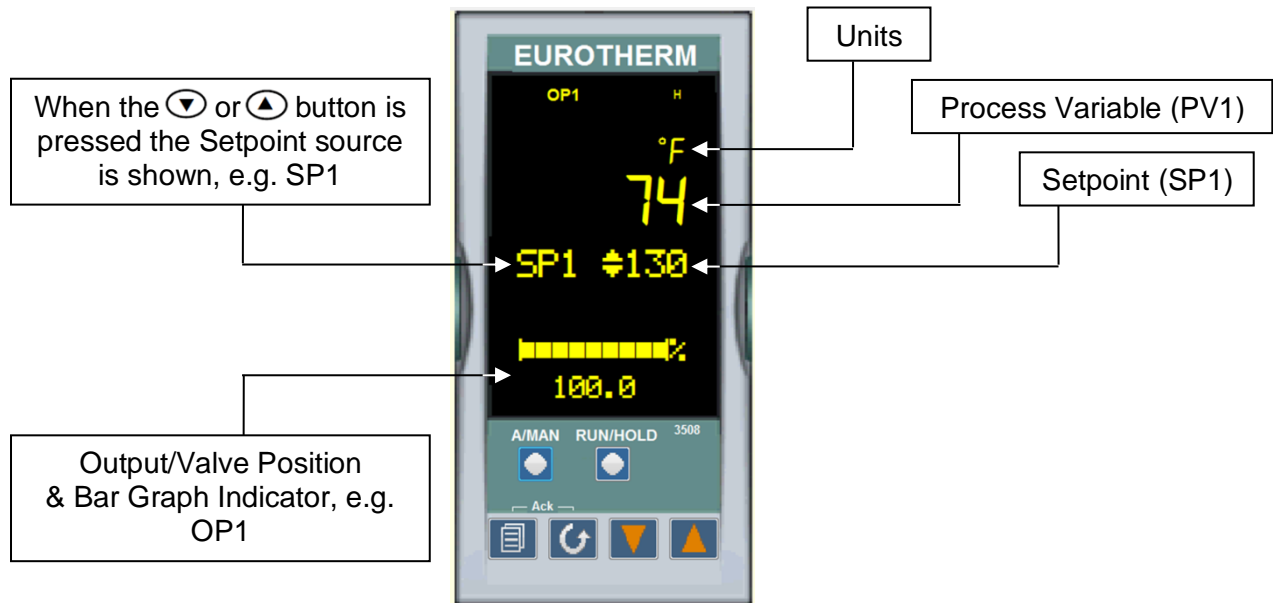

<p>A/MAN This button can be disabled</p>	<p>Toggles the selected loop between Auto and Manual operation. Manual operation means that the controller output power is adjusted by the user. The input sensor is still connected and reading the PV but the control loop is open. Auto means that the controller is automatically adjusting the output to maintain control, ie the loop is closed. If the controller is in manual mode, 'MAN' light will be indicated. If the controller is powered down in Manual operation it will resume this mode when it is powered up again.</p>
<p>PROG</p>	<p>To select the programmer summary page</p>
<p>RUN/HOLD This button can be disabled</p>	<p>Press once to start a program. 'RUN' will be indicated Press again to hold a program. 'HLD' will be indicated Press and hold for at least two seconds to reset a program. 'RUN' will flash at the end of a program 'HLD' will flash during holdback</p>
	<p>Press to select new PAGE headings</p>
	<p>Press to select a new parameter in the page</p>
	<p>Press to decrease an analogue value, or to change the state of a digital value</p>
	<p>Press to increase an analogue value, or to change the state of a digital value</p>

A.2 Normal Operation Home Display



A.3 Beacon Display and Description

OP1	In a single loop controller OP1 and OP2 operate channel 1 and 2 outputs respectively for the configured loop.
MAN	Illuminates when manual mode active. If the HOME display is showing the dual loop overview, MAN illuminates if Loop 1 is in manual. If the Loop 1 or Loop 2 overviews are being displayed MAN applies to the loop being displayed.
REM	Illuminates when remote setpoint active
ALM	If an alarm occurs the red alarm beacon flashes accompanied by message showing source of alarm. To acknowledge press  and  . The message disappears. If the alarm condition is still present the beacon lights continuously. When cleared it will extinguish.
H	Flashes when H Channel comms active

A.4 Selecting Auto/Manual Operation

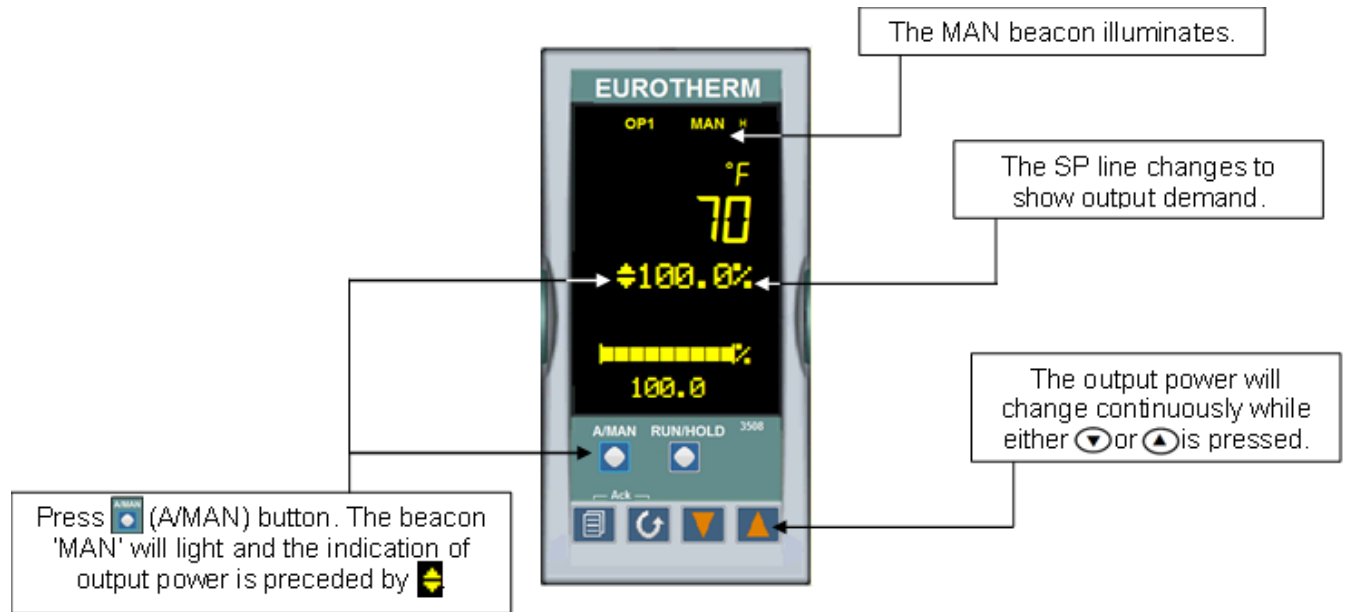

A.5 Eurotherm 3508 Access Levels

Level	Pass Code
Level 1	Default
Level 2	42
Level 3	106
Config	303

Level 1 has no security password since it contains a minimal set of parameters generally sufficient to run the process on a daily basis.

Level 2 allows parameters, such as those used in commissioning a controller, to be adjusted.

Level 3 makes all operating parameters available and alterable (if not read only). Examples are:

- Range limits
- setting alarm levels
- communications address.

The instrument will continue to control when in **Levels 1, 2 or 3**.

Configuration Level makes available all parameters so there is no need to switch between configuration and operation levels during commissioning. It is designed for those who may wish to change the fundamental characteristics of the instrument to match the process. Examples are **Input (thermocouple)** type, **Alarm** type and **Communications** type.

In **Configuration Level** the controller will not necessarily be controlling the process or providing alarm indication. Do not select configuration level on a live process.

A.6 Selecting Access Levels

1. From any display press and hold the PAGE (📄) button. After a few seconds the display will enter the **Access** List & show: Goto ⚡ **Level 1**.

NOTE: Press SCROLL (🔄) button to scroll through the list of Access parameters. If no button is pressed for about 2 minutes the display returns to the HOME display.

2. Press UP ▲ or DOWN ▼ button to select access level.
3. Use UP ▲ and DOWN ▼ buttons to scroll to passcode (1-999) .

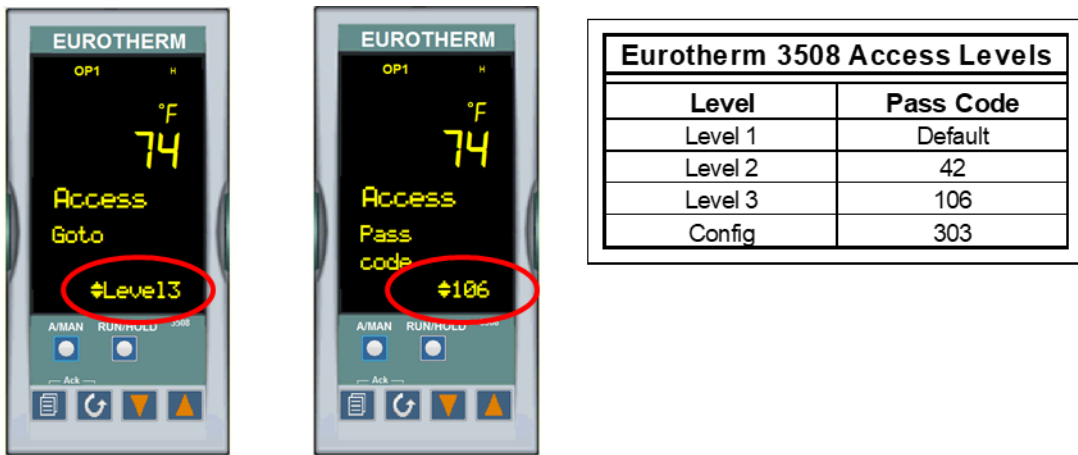





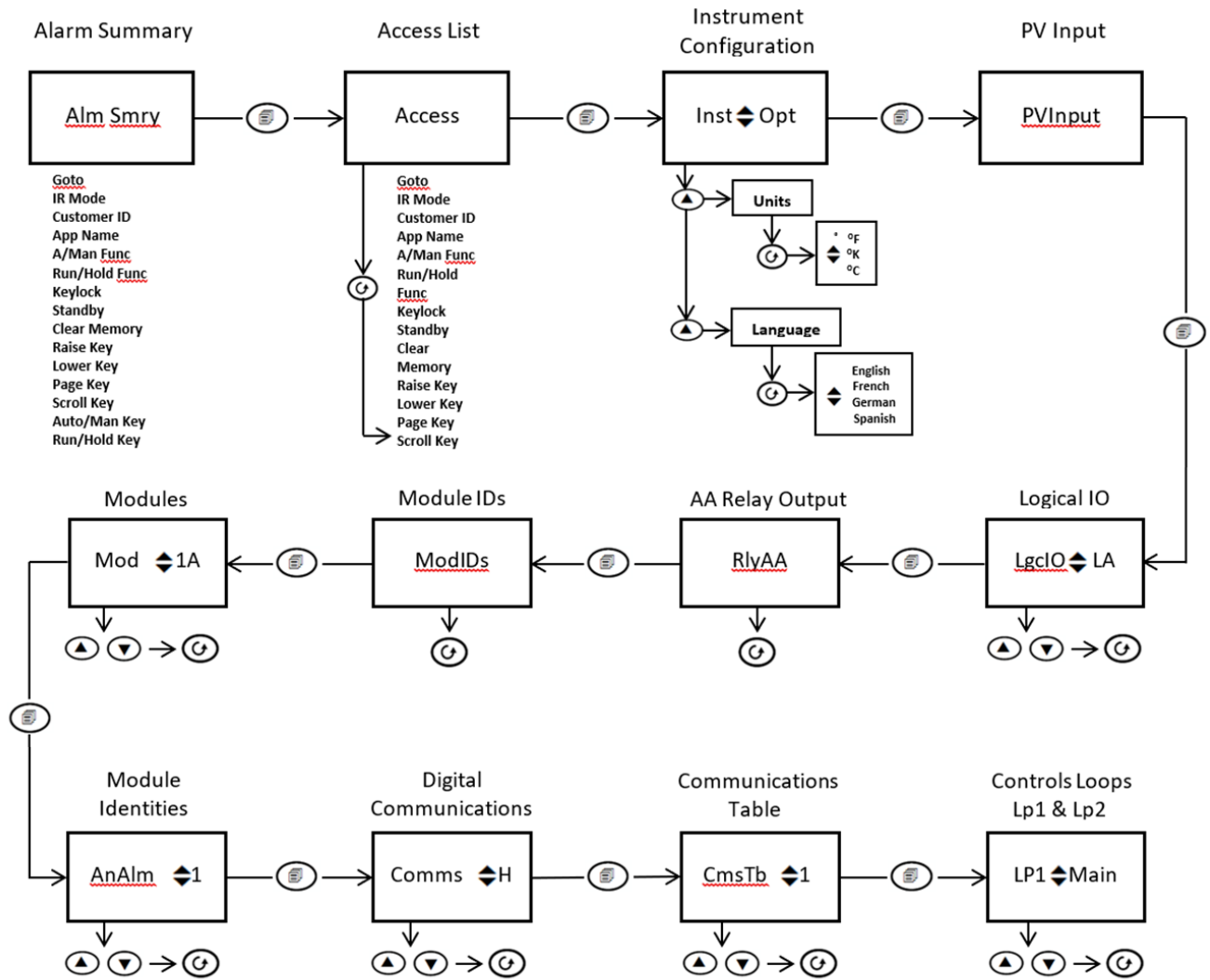

Note: It is not necessary to enter a code when changing to a lower level.

A.7 Function Block Navigation Diagram



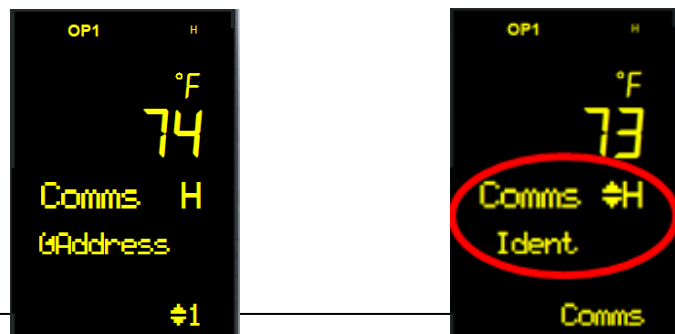

A.8 Changing Modbus Address

1. From Access Level 3 press  until the Digital Communications Function Block is displayed.
2. Press  or  until Comms Identity “H” is displayed.
3. Press  until the **Address** Parameter is displayed.
4. Press  or  until the desired Comm Address is displayed.



A.9 Transition From Local To Remote Setpoint Control

1. Press  until the **Control Loop 1 (Lp1)** Function Block is displayed.
2. Press  or  until **Setpoint (SP)** is displayed.

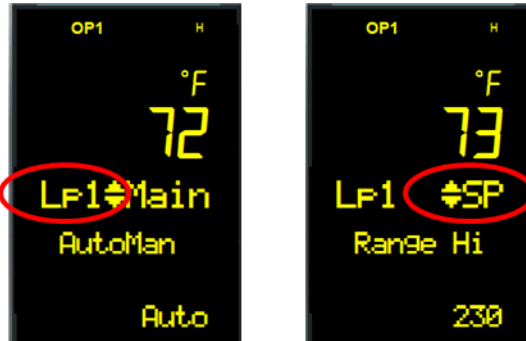

3. Press  until the **Alternate Setpoint Enable (Alt SP En)** is displayed.
4. Press  or  to select YES.

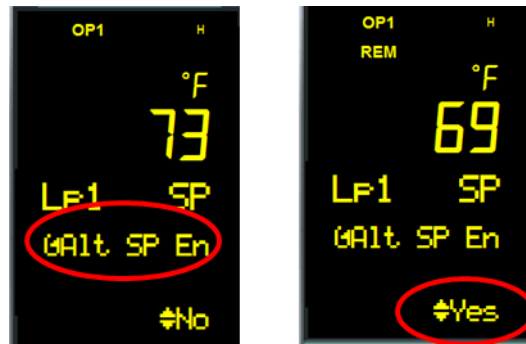

5. The **Remote Beacon** will appear on the Display.
6. Write the **Remote Setpoint to Modbus Holding Register 485 (AltSP)**.

APPENDIX B - MODBUS CONTROL AND COMMUNICATION

MODBUS CONTROL AND COMMUNICATION

**TEMPERATURE CONTROLLER
(Eurotherm 2408) PROCEDURES**

**MODBUS COMMUNICATION INFORMATION
&
PROCESS / DIAGNOSTIC ALARM MESSAGES**

B.1 TEMPERATURE CONTROLLER (EUROTHERM 2408) PROCEDURES

The following sections provide the procedures to add a Modbus Communication board to the Temperature Controller and change communication addresses.

B.1.1 Adding a Communication Board to the Temperature Controller

Parts Needed:

- a. ECS/SP Control Box Assembly, P/N: 69096-TAB]
- b. Temperature Indicating Controller, P/N: 64008
- c. Communications Board, P/N: 64009-TAB

ADDING A COMMUNICATION BOARD Instructions

1. Turn off power to ECS/SP Control Box Assembly
2. Slide out Temperature Indicating Controller (P/N: 64008) from Control Box Assembly by gently pushing the indicated latching ears to the side (See Figure A-1).



Figure A-1

3. Slide Communications Board (P/N 64009-TAB) into Temperature Indicating Controller slot (COMMS 1). See Figure 2. Make sure to push Communications Board all the way in to ensure it is firmly seated in its slot.

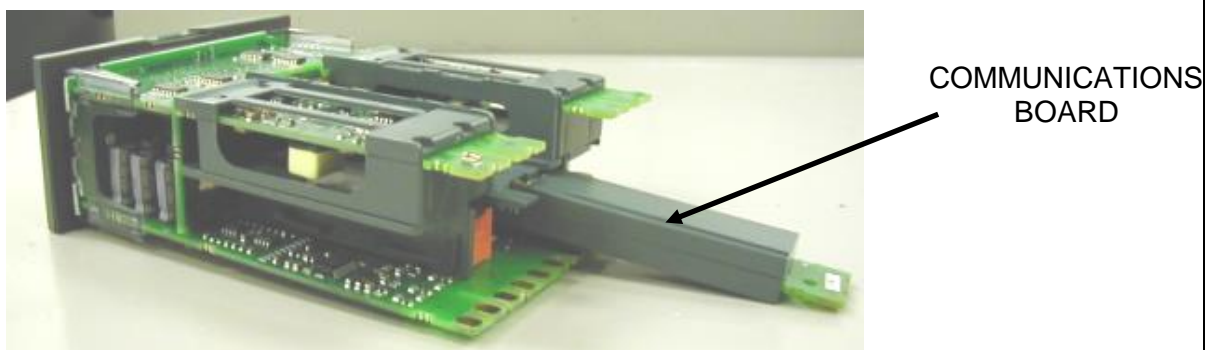

Figure A-2

ADDING A COMMUNICATION BOARD Instructions

- Place Temperature Indicating Controller back into Control Box Assembly and power up unit. The following screen will appear. (See Figure A-3)



- The Controller will report a hardware error as indicated in Figure A-3. Press the ▲ (up) arrow key located on the right side of the Temperature Controller until “8” appears on the lower half of the screen.
- Press the page button located on the left side of the Temperature Indicating Controller until “Exit” appears on the top half of the screen.
- Press the ▲ / ▼ (up/down) arrow key to choose “yes”.
- Wait a moment as the screen updates. The hardware error will no longer be displayed.
- This completes installation of the Communications Board.

B.1.2 Changing the Temperature Controller Communication Addresses

NOTE: Refer to the button map at the bottom of the display, Figure A-4, for all panel navigation instructions.

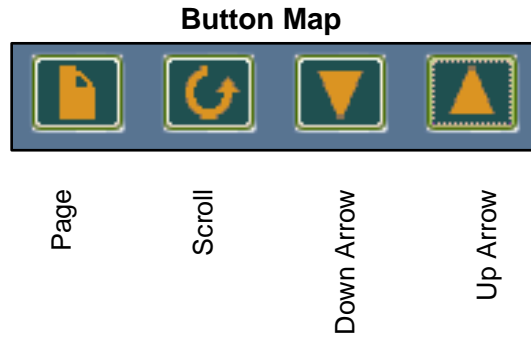

Figure A-4

The Temperature Controller address is defaulted to 1 from the factory. To change the MODBUS address, proceed as follows:

1. **Page** to the ACCS list and **Scroll** down to *codE*.



2. Enter 24 using the **Up Arrow**.
The number will flash and display PASS.
3. **Scroll** to Goto (current value is OPER) and use the **Down Arrow** to enter a value of Full. The entry confirms by flashing the lower display momentarily off and then on.



4. Go to the home screen by pressing the **Page** and **Scroll** buttons at the same time.



5. **Page** to the *cmS* list.
6. **Scroll** to the *Addr* screen.
7. Use the **Up Arrow** to select the desired address number.



8. Go to the home screen by pressing the **Page** and **Scroll** buttons at the same time.
9. **Page** to the ACCS list and change the code to anything other than 24. The *codE* number you enter will flash off and then on to 0 to confirm that access is now set to the OPEr level and it is safe to return to use.



10. Confirm that the *Addr* is set properly by pressing the **Page** button until the cmS list is displayed. **Scroll** to *Addr*. If the value is correct you are done; if not, repeat the steps in this procedure.



B.2 MODBUS COMMUNICATION INFORMATION

NOTE: The Eurotherm 2400 Controller supports MODBUS RTU transmission. The default settings are: 9600 Baud Rate, one start bit, eight data bits, one stop bit, & no parity bit.

EUROTHERM SERIES 2400 CONTROLLER MODBUS POINTS						
MODBUS Data Address	Menu Item	Menu Item Description	Units & Range	Default/Comments	Register Type	Ref. 1 Comm. Guide
5	w.SP	Setpoint	40-205°F	140°F, Address to read value	Read Only	5-4
24	SP 1	Setpoint	40-180°F	140°F, Address to change value	Write	5-11
1	Top Value	Outlet Temp	40-205°F	Same value as front display	Read Only	5-3
133	LoGH	Peak Temp	40-205°F	Resets on Power Loss	Read Only	5-15
135	LoGA	Average Temp	40-205°F	Resets on Power Loss	Read Only	5-15
134	LoGL	Low Temp	40-205°F	Resets on Power Loss	Read Only	5-15
13 (set) 74 (status, 0 = safe 1 = alarm)	AL 1	Over Temp Alarm	40-205°F	20°F above setpoint; Alarm Type 17: Deviation High	Read Only	5-7 5-20
14 (set) 74 (status, 0 = safe 1 = alarm)	AL 2 (FSH)	Full Scale High Alarm	205°F	205 ° F Alarm Type 2: Full Scale High	Read Only	5-7 5-20
258	Sbr	Feedback Sensor Break	Status: 0: Good 1: Failed	Denotes Feedback Sensor Failure/Open Circuit	Read Only	5-18
289	Li 1	Feedback Sensor Temp	40-180°F	Sensor input to controller, same as display temp.	Read Only	5-14
290	Li 2	Feed Forward Temperature	40-180°F	Sensor input to controller	Read Only	5-14
3	OP	Control Output Signal	%	Correlates to valve position	Read Only	5-4

REFERENCE DOCUMENTS:

1. Eurotherm 2000 Series Communications Handbook, # HA026230
2. Eurotherm 2404/2408 Control Setpoint Programmer Installation and Operation Handbook, # HA025132

B.3 PROCESS & DIAGNOSTIC ALARMS

The Process and Diagnostic Alarms that can appear in the Temperature Controller display are listed in the following Tables.







PROCESS ALARMS	
DISPLAY	MEANING
_FSL*	PV Full Scale Low Alarm.
_FSH*	PV Full Scale High Alarm.
_dEu*	PV Deviation Band Alarm
_dHi*	PV Deviation High Alarm
_dLo*	PV Deviation Low Alarm

DIAGNOSTIC ALARMS		
DISPLAY	MEANING	WHAT TO DO`
EE.Er	<i>Electrically Erasable Memory Error</i> : The value of an operator, or configuration, parameter has been corrupted.	This fault will automatically take you into Configuration level. Check all of the configuration parameters before returning to Operator level. Once in Operator level, check all of the operator parameters before resuming normal operation. If the fault persists, or occurs frequently, contact your supplier
S.br	Sensor Break: Input sensor is unreliable or the input signal is out of range.	Check that the sensor is correctly connected
Hw.Er	Hardware Error Indication that a module is of the wrong type, missing, or faulty.	Check to ensure that the correct items are installed. See page A-4 for procedure to clear the Hardware Error.
no.io	No I/O None of the expected I/O items are installed	This error message normally occurs when pre-configuring a controller without installing any of the required I/O modules.
rmt.F	Remote input failure. The remote DC input is open or shorted	Check for open or short circuit wiring on the remote DC input.
LLLL	Out of range low reading	Check the value of the input
HHHH	Out of range high reading	Check the value of the input
Err1	Error 1: ROM self-test fail	Return Controller for repair

DIAGNOSTIC ALARMS		
DISPLAY	MEANING	WHAT TO DO`
Err2	Error 2: RAM self-test fail	Return Controller for repair
Err3	Error 3: Watchdog fail	Return Controller for repair
Err4	Error 4: Keyboard failure. Stuck button or button was pressed during power-up	Switch power off and then on, without touching any of the controller buttons
Err5	Error 5: Faulty internal communication	Check printed circuit board interconnections. If the fault cannot be cleared, return the controller for repair.
Err6	Digital filter chip faulty or loose board inside controller	Return Controller for repair
Err7	PV ID failure	Return Controller for repair
Err8	Module 1 ID failure	Faulty or loose module, or isolation problem
Err9	Module 2 ID failure	Faulty or loose module, or isolation problem
ErrA	Module 3 ID failure	Faulty or loose module, or isolation problem
dCF	DC output failure	Return Controller for repair
OPEn	Secondary Input Missing or Disconnected	This error may result from no power to the flow meter (check for green power light on rear of meter or 0-5V flowmeter signal connections), or a disconnection of the Molex connector between feedforward sensor and the Eurotherm controller.

B3.1. Clearing Hardware Error (Hw.Er) Display

To clear a Hardware Error and reset the Temperature Controller, proceed as follows:

CLEARING HARDWARE ERROR Display Instructions
<ol style="list-style-type: none"> 1. Display flashes Hw.Er after adding or removing comm. bd. 2. Simultaneously press the Page () and Scroll () buttons on the Temperature Controller. 3. Using the Up (▲) arrow button, change the password to “8”. 4. Simultaneously press the Page () and Scroll () buttons again and observe the Temperature Controller display. The top line will display “8” and the bottom line will display “NO”. 5. Press the Up (▲) arrow button to toggle the display from “NO” to “YES”. 6. Simultaneously press the Page () and Scroll () buttons to “Reset” the Temperature Controller and clear the Hardware Error.

(This page left intentionally blank)

APPENDIX C – ECS/SP WIRING DIAGRAM & TERMINAL BLOCK CONNECTIONS

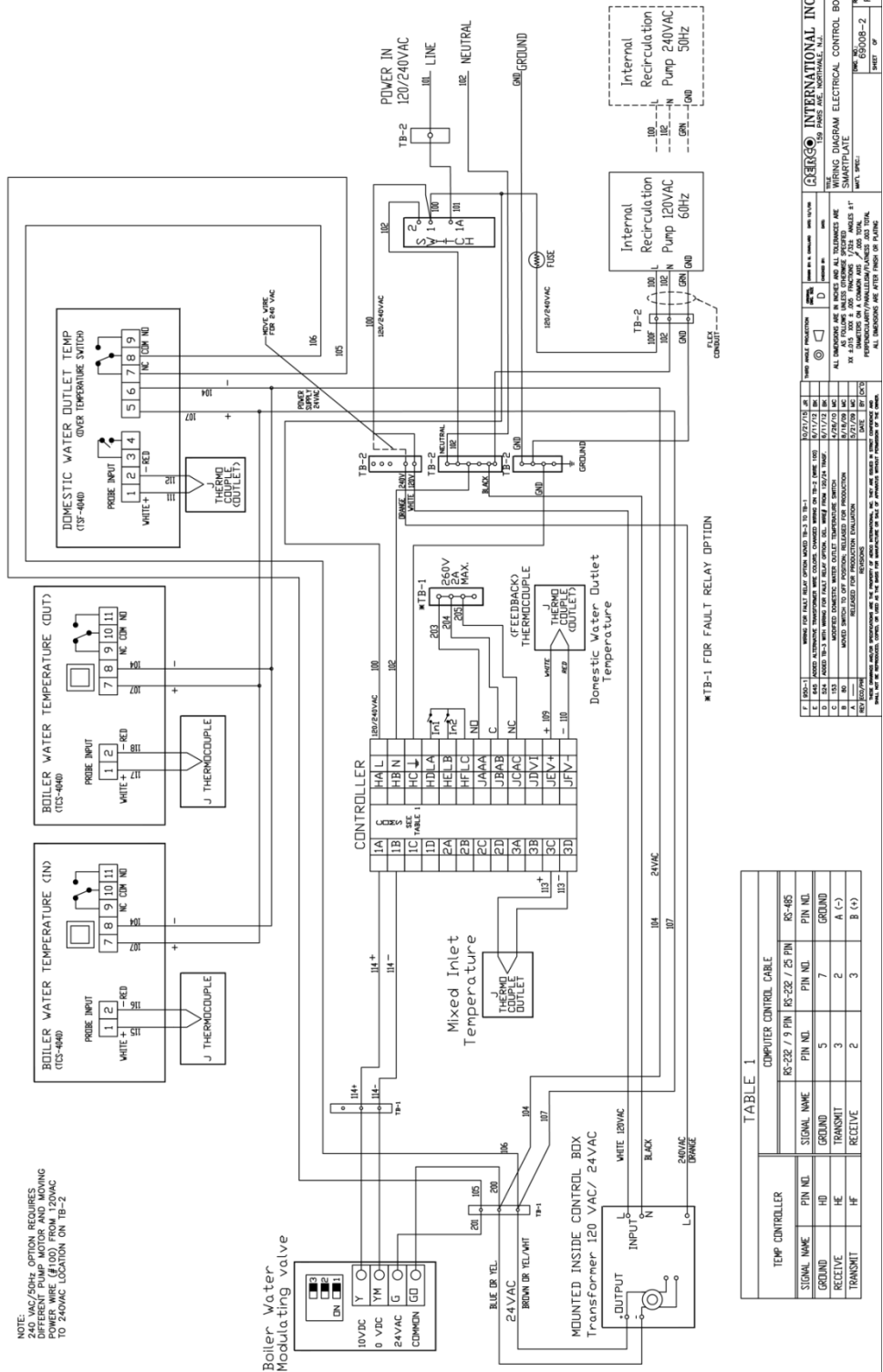

Drawing Number: 69008-2 rev F

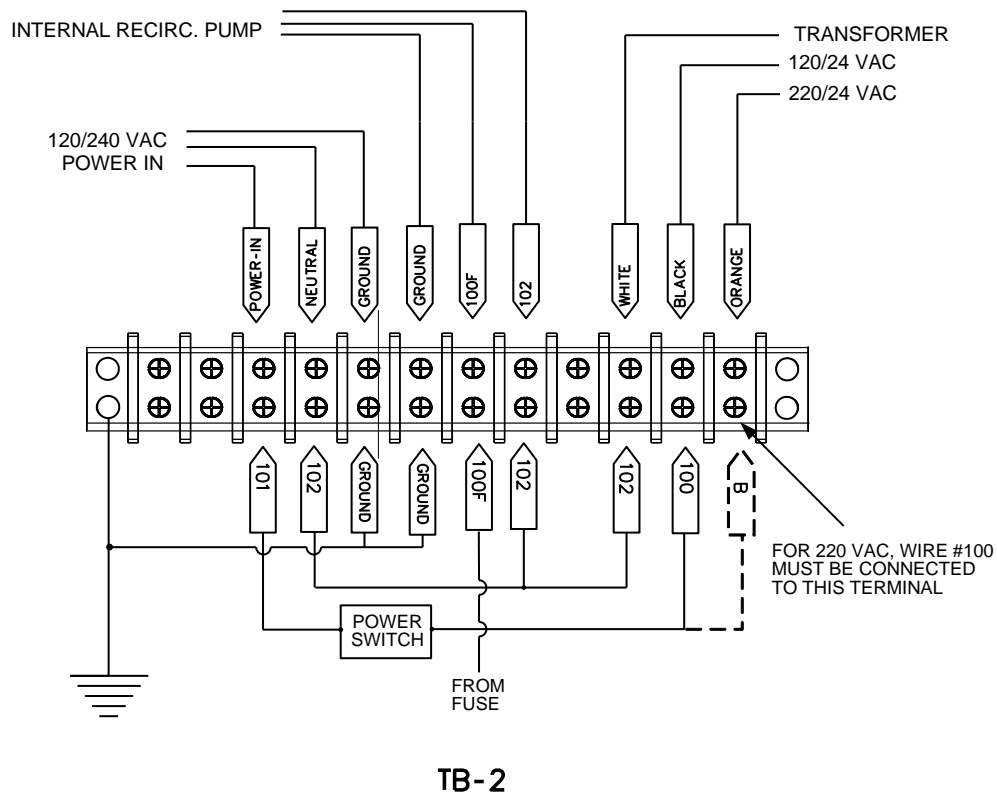
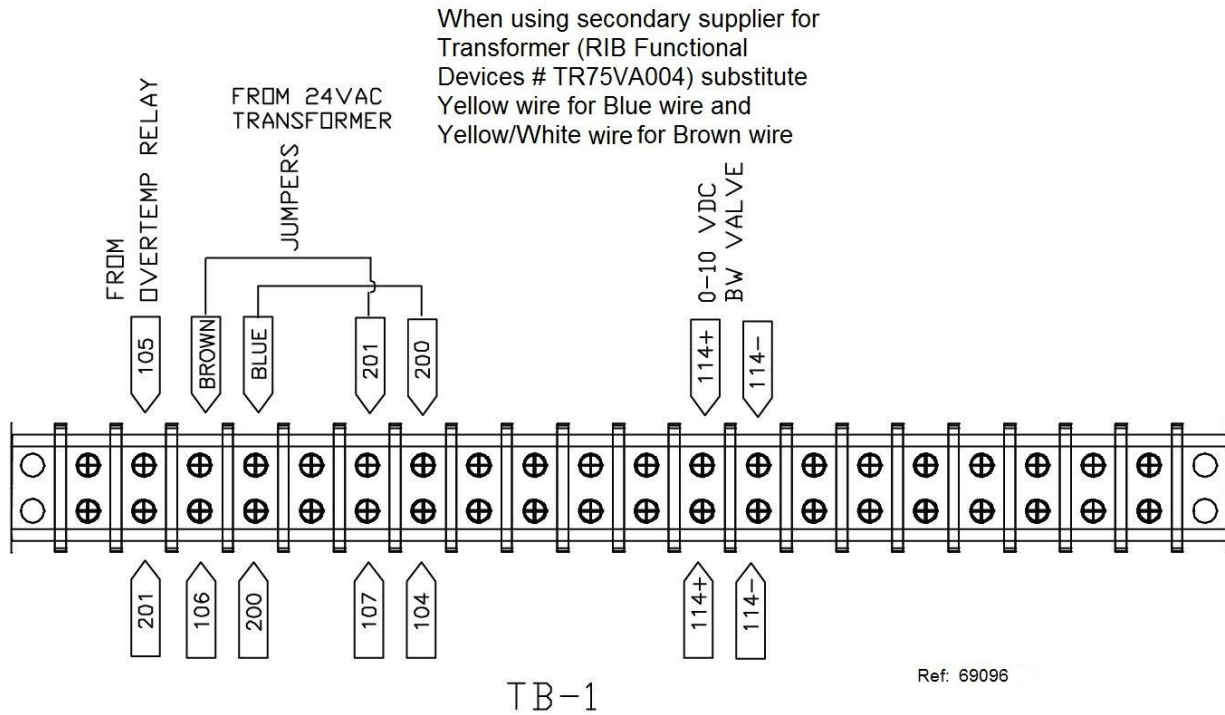

APPENDIX D – SMART PLATE PIPING DRAWINGS

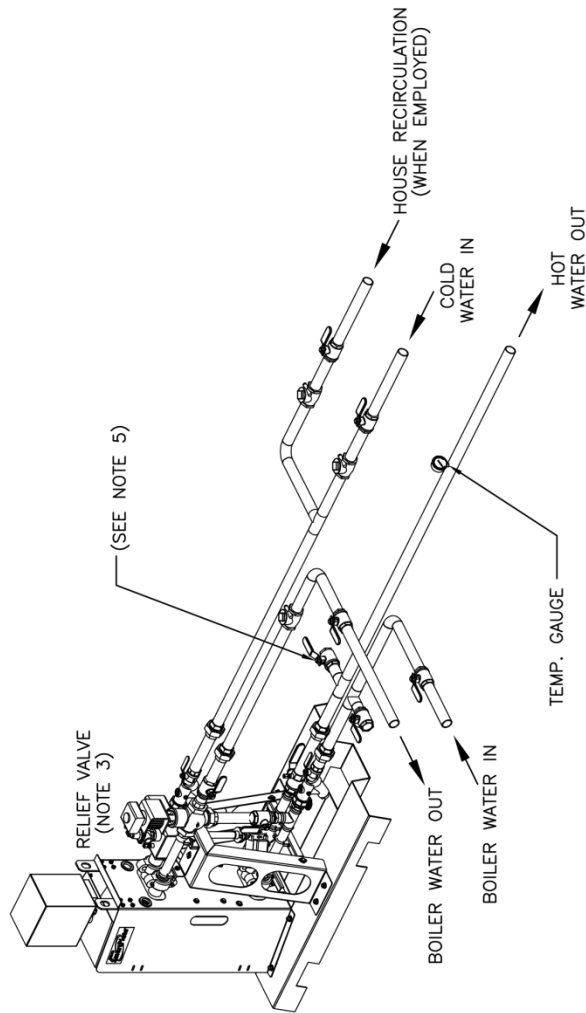

 INTERNATIONAL, INC. <small>Blauvelt, NY 10913</small>	
SMARTPLATE WATER TO WATER HEAT EXCHANGER SINGLE UNIT	
DWN. BY _____ SCALE _____ APPD. _____	DATE _____
REV. _____ SD-A-772	C

- NOTES:
1. FOR ACTUAL SIZES AND LOCATIONS OF PIPING AND OTHER CONNECTIONS TO THE HEATER, SEE DIMENSIONAL DRAWING.
 2. REDUCERS, ON THE WATER INLET SIDE, SHOULD BE LOCATED ADJACENT TO THE HEATER. EXPANSION FITTINGS, ON THE WATER INLET SIDE, SHOULD BE LOCATED AS FAR AS POSSIBLE FROM THE HEATER.
 3. THE WATER INLET SIDE, SHOULD BE LOCATED AS FAR AS POSSIBLE FROM THE HEATER. EXPANSION FITTINGS, ON THE WATER INLET SIDE, SHOULD BE LOCATED AS FAR AS POSSIBLE FROM THE HEATER.
 3. DRAIN VALVE SHOULD BE PIPED DIRECTLY TO A FLOOR DRAIN. RELIEF VALVE DISCHARGE SHOULD BE PIPED TO THE NEAREST FLOOR DRAIN. WHEN NO FLOOR DRAIN IS AVAILABLE, THE RELIEF VALVE DISCHARGE SHOULD BE PIPED VERTICALLY TO A HEIGHT 18" ABOVE THE FLOOR.
 4. REFER TO SMARTPLATE APPLICATIONS GUIDE, SP-1010, TO DETERMINE IF SYSTEM REQUIRES A BUFFER TANK.
 5. INSTALL A HOSE CONNECTION AT THE HOT WATER OUTLET.

Drawing Number: SD-A-772 rev C

APPENDIX D – SMARTPLATE PIPING DRAWINGS

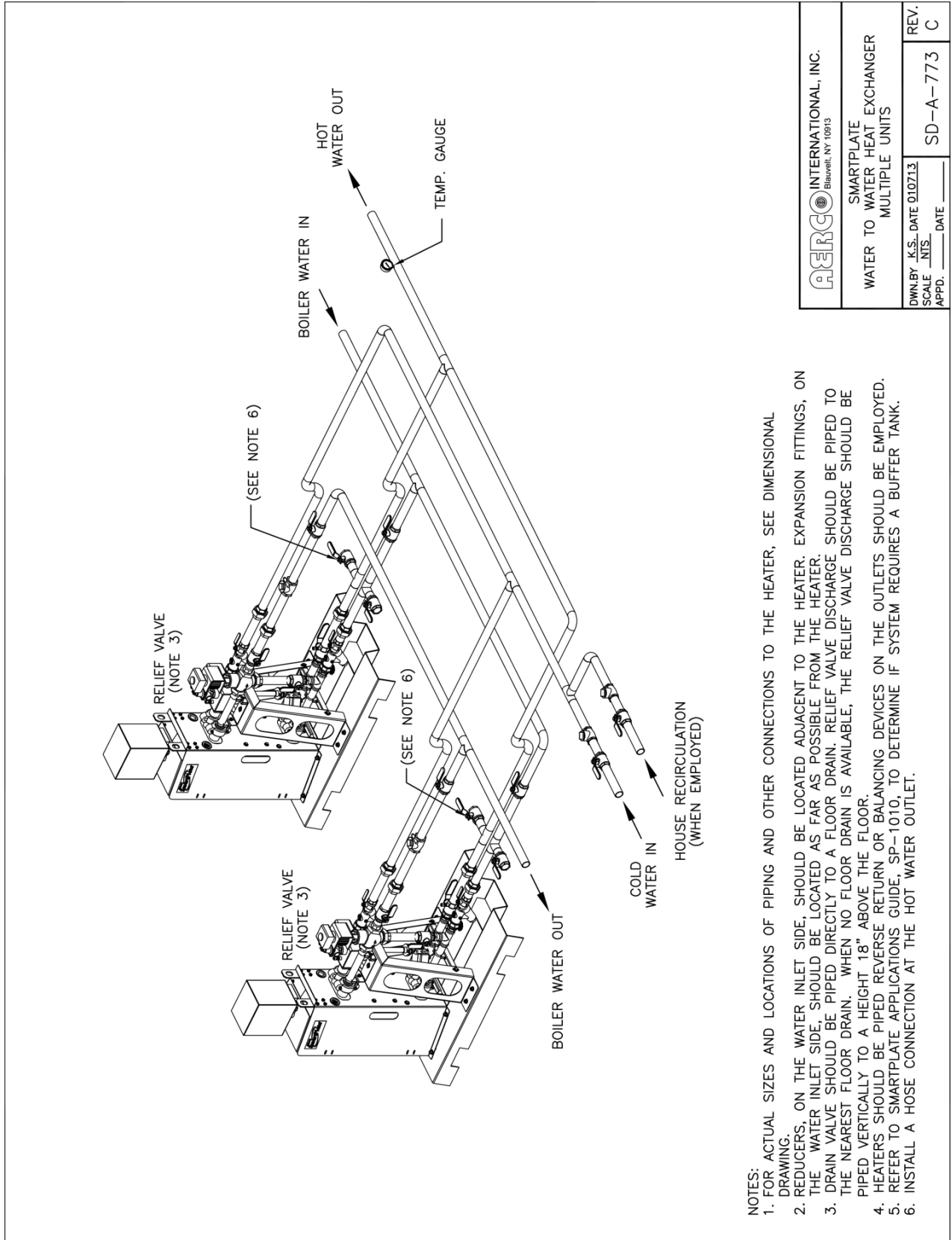

- NOTES:
1. FOR ACTUAL SIZES AND LOCATIONS OF PIPING AND OTHER CONNECTIONS TO THE HEATER, SEE DIMENSIONAL DRAWING.
 2. REDUCERS, ON THE WATER INLET SIDE, SHOULD BE LOCATED ADJACENT TO THE HEATER. EXPANSION FITTINGS, ON THE WATER INLET SIDE, SHOULD BE LOCATED AS FAR AS POSSIBLE FROM THE HEATER.
 3. DRAIN VALVE SHOULD BE PIPED DIRECTLY TO A FLOOR DRAIN. RELIEF VALVE DISCHARGE SHOULD BE PIPED TO THE NEAREST FLOOR DRAIN. WHEN NO FLOOR DRAIN IS AVAILABLE, THE RELIEF VALVE DISCHARGE SHOULD BE PIPED VERTICALLY TO A HEIGHT 18" ABOVE THE FLOOR.
 4. HEATERS SHOULD BE PIPED REVERSE RETURN OR BALANCING DEVICES ON THE OUTLETS SHOULD BE EMPLOYED.
 5. REFER TO SMARTPLATE APPLICATIONS GUIDE, SP-1010, TO DETERMINE IF SYSTEM REQUIRES A BUFFER TANK.
 6. INSTALL A HOSE CONNECTION AT THE HOT WATER OUTLET.

 INTERNATIONAL, INC. <small>Blauvelt, NY 10613</small>	
SMARTPLATE WATER TO WATER HEAT EXCHANGER MULTIPLE UNITS	
DWN BY <u> </u> K.S. DATE 01/07/13 SCALE <u> </u> INTS. <u> </u> DATE <u> </u> APPD. <u> </u>	REV. <u> </u> SD-A-773 C

Drawing Number: SD-A-773 rev C

APPENDIX D – SMARTPLATE PIPING DRAWINGS

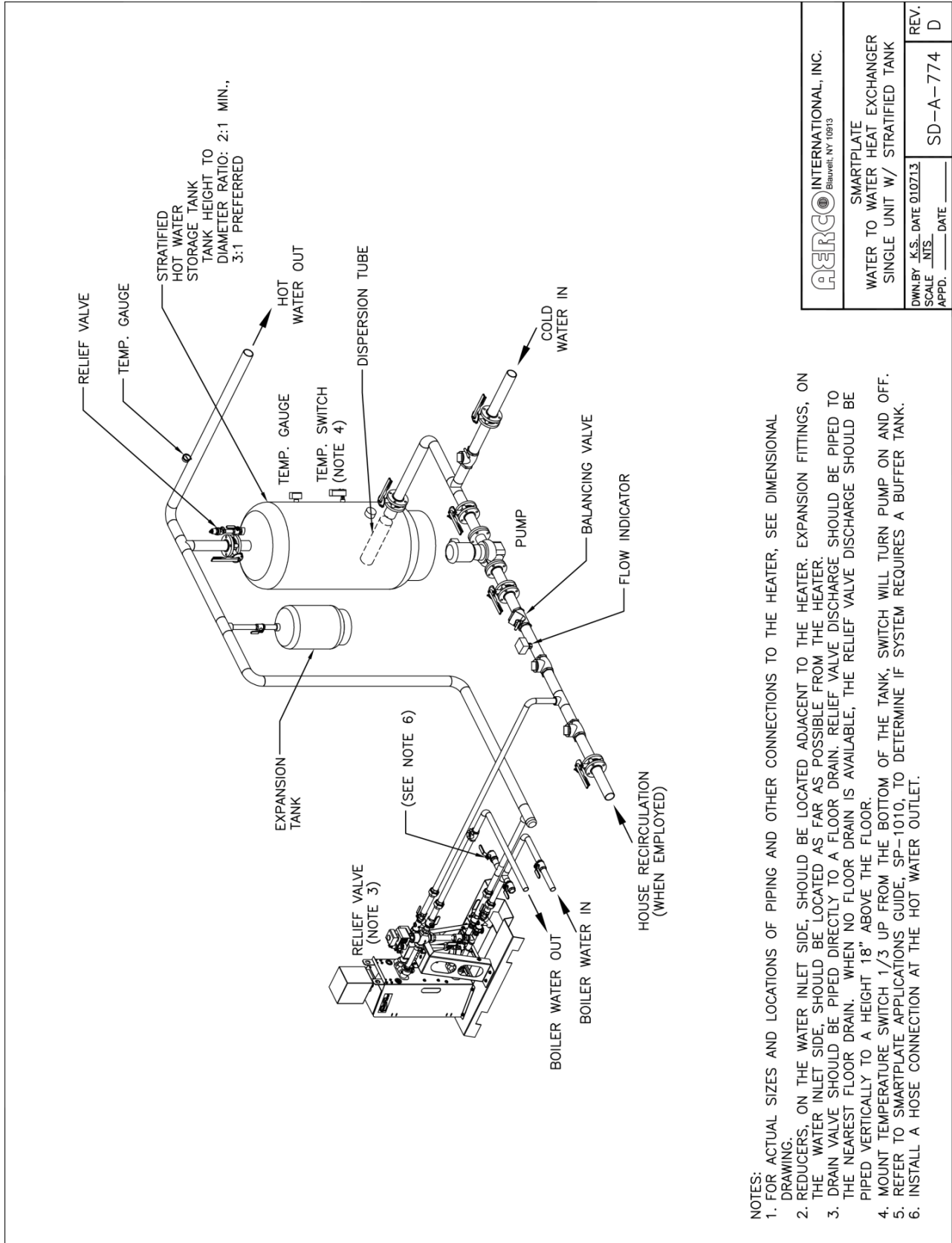

AERCO <small>Blauvelt, NY 10913</small>	
SMARTPLATE WATER TO WATER HEAT EXCHANGER SINGLE UNIT W/ STRATIFIED TANK	
DWN.BY: I.S. DATE 010713 SCALE: NTS. DATE _____ APPD. _____ DATE _____	REV. _____ SD-A-774 D

- NOTES:
- FOR ACTUAL SIZES AND LOCATIONS OF PIPING AND OTHER CONNECTIONS TO THE HEATER, SEE DIMENSIONAL DRAWING.
 - REDUCERS, ON THE WATER INLET SIDE, SHOULD BE LOCATED ADJACENT TO THE HEATER. EXPANSION FITTINGS, ON THE WATER INLET SIDE, SHOULD BE LOCATED AS FAR AS POSSIBLE FROM THE HEATER.
 - THE WATER INLET SIDE, SHOULD BE LOCATED AS FAR AS POSSIBLE FROM THE HEATER. RELIEF VALVE DISCHARGE SHOULD BE PIPED TO A FLOOR DRAIN. RELIEF VALVE DISCHARGE SHOULD BE PIPED TO THE NEAREST FLOOR DRAIN. WHEN NO FLOOR DRAIN IS AVAILABLE, THE RELIEF VALVE DISCHARGE SHOULD BE PIPED VERTICALLY TO A HEIGHT 18" ABOVE THE FLOOR.
 - MOUNT TEMPERATURE SWITCH 1/3 UP FROM THE BOTTOM OF THE TANK, SWITCH WILL TURN PUMP ON AND OFF.
 - REFER TO SMARTPLATE APPLICATIONS GUIDE, SP-1010, TO DETERMINE IF SYSTEM REQUIRES A BUFFER TANK.
 - INSTALL A HOSE CONNECTION AT THE HOT WATER OUTLET.

Drawing Number: SD-A-774 rev D

APPENDIX D – SMARTPLATE PIPING DRAWINGS

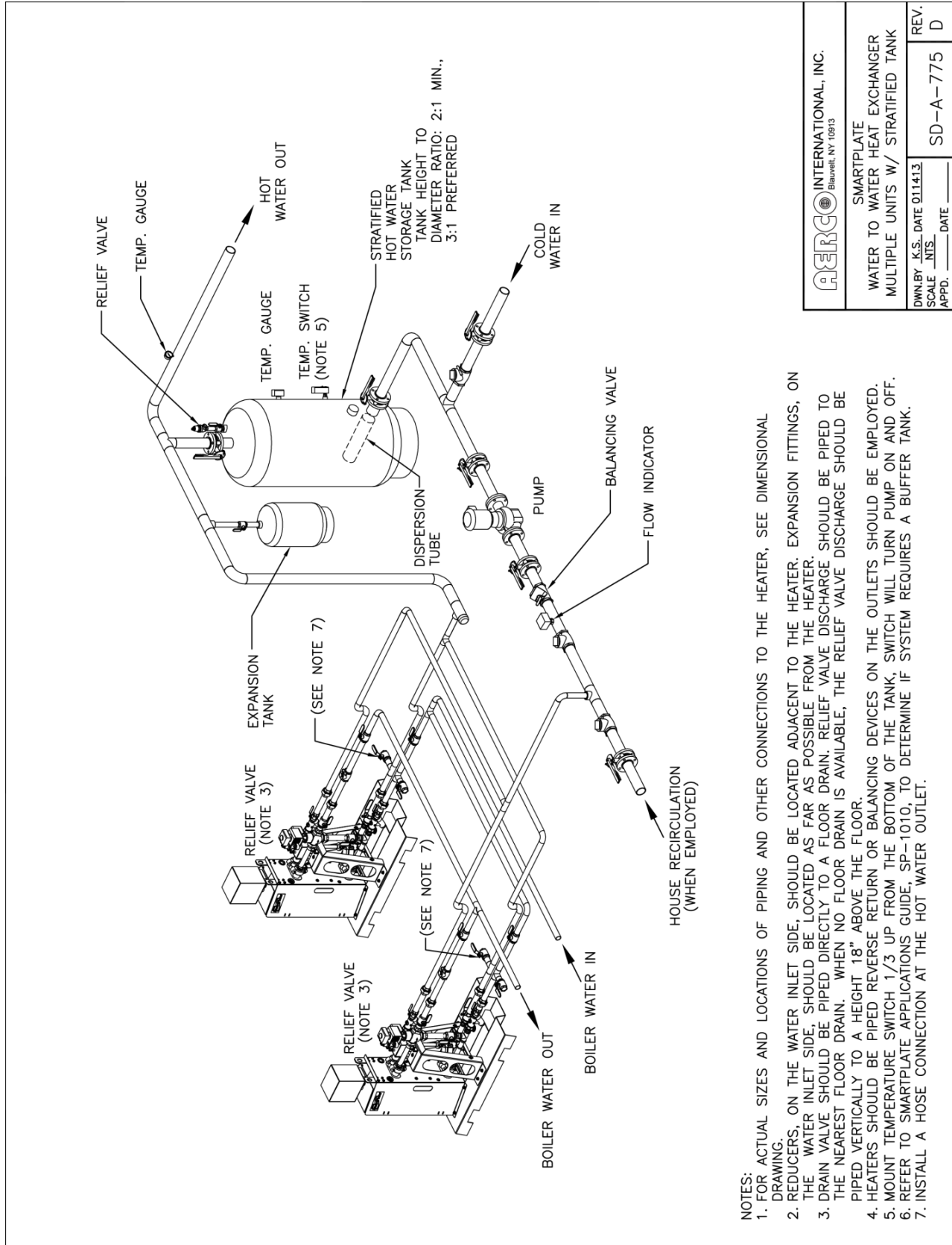

AERCO <small>Blauvelt, NY 09913</small>	
SMARTPLATE WATER TO WATER HEAT EXCHANGER MULTIPLE UNITS W/ STRATIFIED TANK	
DWN.BY: J.S. DATE 011413	REV. _____
SCALE: _____	APPD. _____
SD-A-775	D

- NOTES:
- FOR ACTUAL SIZES AND LOCATIONS OF PIPING AND OTHER CONNECTIONS TO THE HEATER, SEE DIMENSIONAL DRAWING.
 - REDUCERS, ON THE WATER INLET SIDE, SHOULD BE LOCATED ADJACENT TO THE HEATER. EXPANSION FITTINGS, ON THE WATER INLET SIDE, SHOULD BE LOCATED AS FAR AS POSSIBLE FROM THE HEATER.
 - DRAIN VALVE SHOULD BE PIPED DIRECTLY TO A FLOOR DRAIN. RELIEF VALVE DISCHARGE SHOULD BE PIPED TO THE NEAREST FLOOR DRAIN. WHEN NO FLOOR DRAIN IS AVAILABLE, THE RELIEF VALVE DISCHARGE SHOULD BE PIPED VERTICALLY TO A HEIGHT 18" ABOVE THE FLOOR.
 - HEATERS SHOULD BE PIPED REVERSE RETURN OR BALANCING DEVICES ON THE OUTLETS SHOULD BE EMPLOYED.
 - MOUNT TEMPERATURE SWITCH 1/3 UP FROM THE BOTTOM OF THE TANK, SWITCH WILL TURN PUMP ON AND OFF.
 - REFER TO SMARTPLATE APPLICATIONS GUIDE, SP-1010, TO DETERMINE IF SYSTEM REQUIRES A BUFFER TANK.
 - INSTALL A HOSE CONNECTION AT THE HOT WATER OUTLET.

Drawing Number: SD-A-775 rev D

APPENDIX D – SMARTPLATE PIPING DRAWINGS

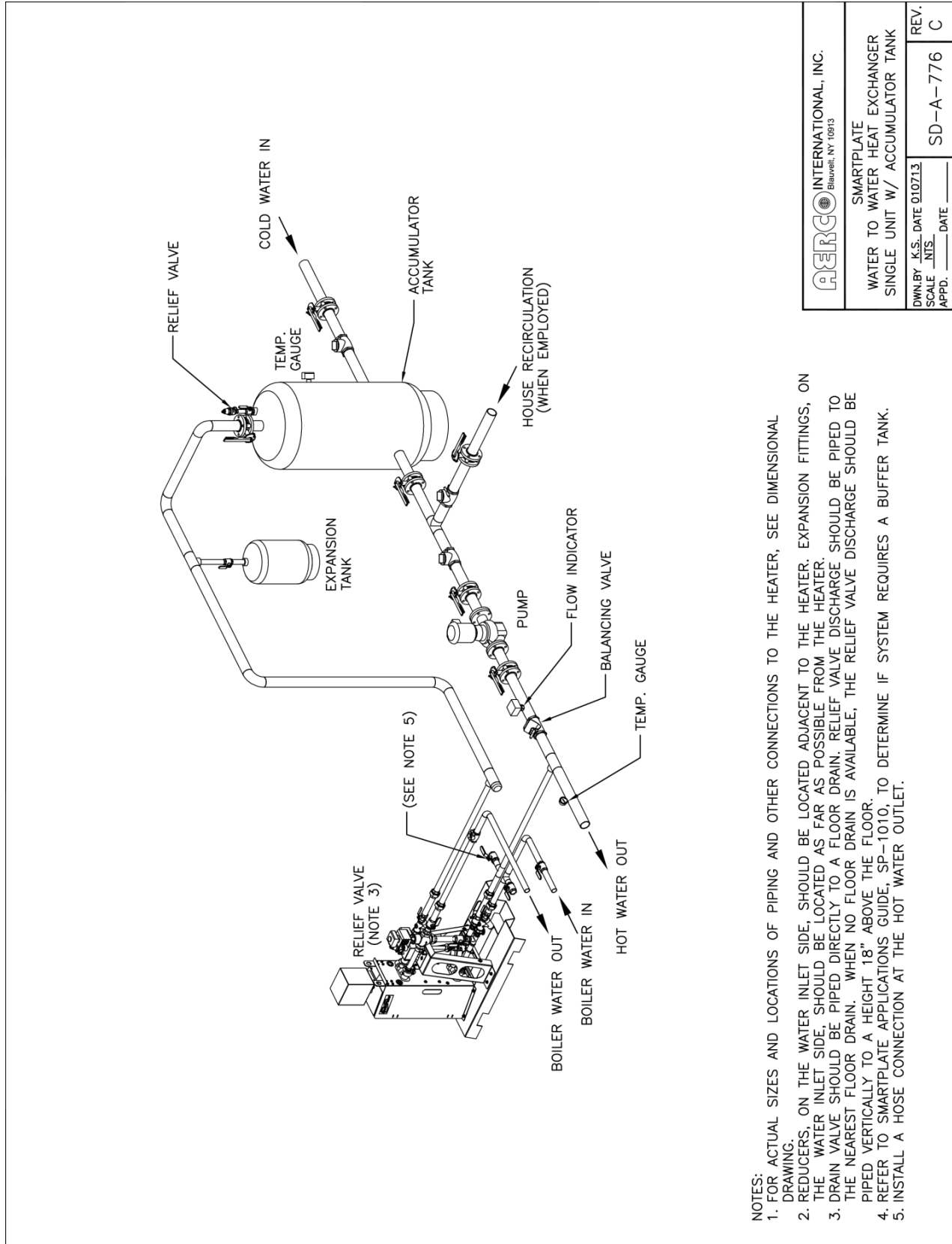

- NOTES:
1. FOR ACTUAL SIZES AND LOCATIONS OF PIPING AND OTHER CONNECTIONS TO THE HEATER, SEE DIMENSIONAL DRAWING.
 2. THE WATER INLET SIDE, SHOULD BE LOCATED ADJACENT TO THE HEATER. EXPANSION FITTINGS, ON THE WATER INLET SIDE, SHOULD BE LOCATED AS FAR AS POSSIBLE FROM THE HEATER.
 3. DRAIN VALVE SHOULD BE PIPED DIRECTLY TO A FLOOR DRAIN. RELIEF VALVE DISCHARGE SHOULD BE PIPED TO THE NEAREST FLOOR DRAIN. WHEN NO FLOOR DRAIN IS AVAILABLE, THE RELIEF VALVE DISCHARGE SHOULD BE PIPED VERTICALLY TO A HEIGHT 18" ABOVE THE FLOOR.
 4. REFER TO SMARTPLATE APPLICATIONS GUIDE, SP-1010, TO DETERMINE IF SYSTEM REQUIRES A BUFFER TANK.
 5. INSTALL A HOSE CONNECTION AT THE HOT WATER OUTLET.

 INTERNATIONAL, INC. Blauvelt, NY 10613	
SMARTPLATE WATER TO WATER HEAT EXCHANGER SINGLE UNIT W/ ACCUMULATOR TANK	
DWN BY <u>NTS</u> DATE <u>010713</u>	REV. <u>C</u>
APPD. _____ DATE _____	SD-A-776

Drawing Number: SD-A-776 rev C

APPENDIX D – SMARTPLATE PIPING DRAWINGS

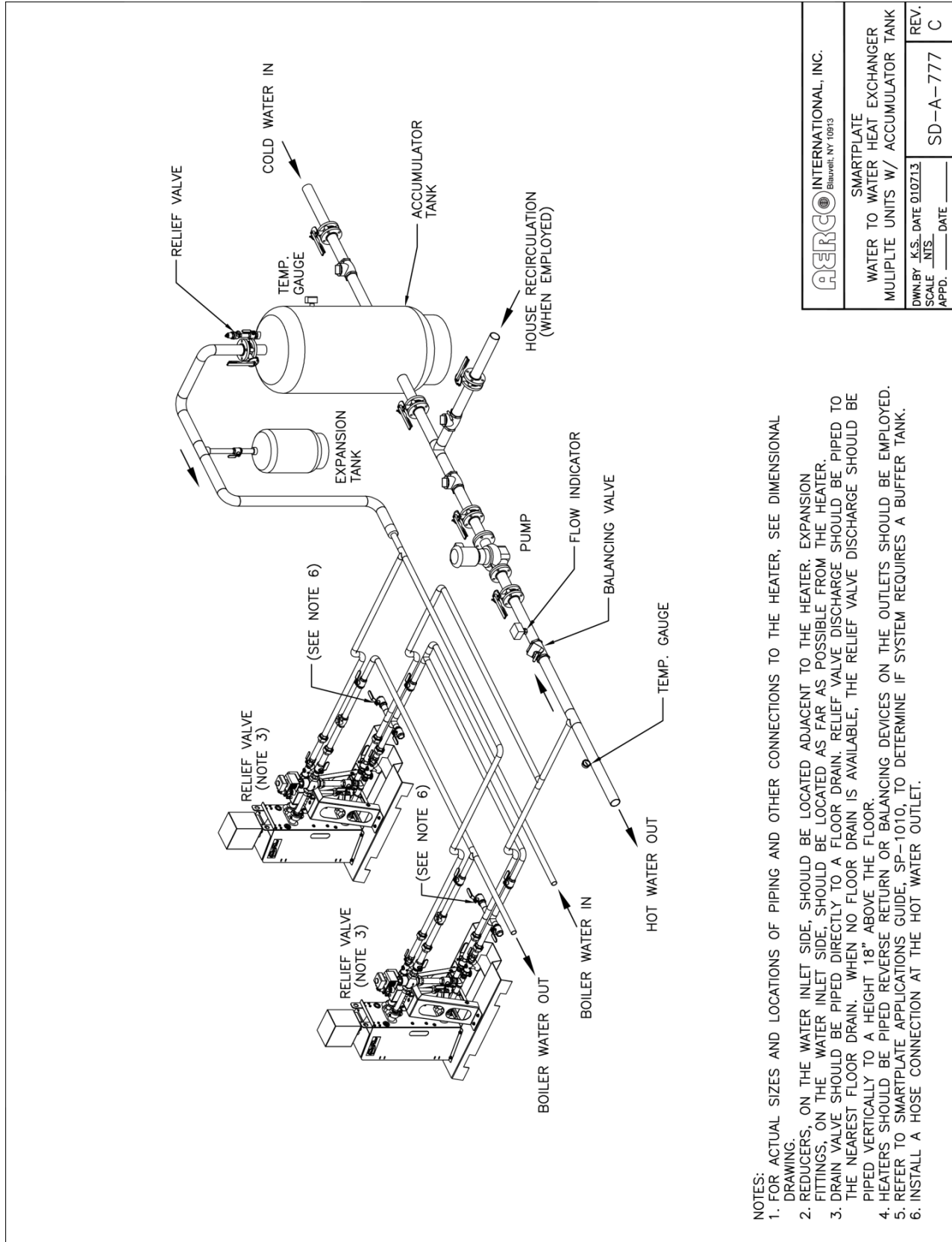

- NOTES:
1. FOR ACTUAL SIZES AND LOCATIONS OF PIPING AND OTHER CONNECTIONS TO THE HEATER, SEE DIMENSIONAL DRAWING.
 2. REDUCERS, ON THE WATER INLET SIDE, SHOULD BE LOCATED ADJACENT TO THE HEATER. EXPANSION FITTINGS, ON THE WATER INLET SIDE, SHOULD BE LOCATED AS FAR AS POSSIBLE FROM THE HEATER.
 3. DRAIN VALVE SHOULD BE PIPED DIRECTLY TO A FLOOR DRAIN. RELIEF VALVE DISCHARGE SHOULD BE PIPED TO THE NEAREST FLOOR DRAIN. WHEN NO FLOOR DRAIN IS AVAILABLE, THE RELIEF VALVE DISCHARGE SHOULD BE PIPED VERTICALLY TO A HEIGHT 18" ABOVE THE FLOOR.
 4. HEATERS SHOULD BE PIPED REVERSE RETURN OR BALANCING DEVICES ON THE OUTLETS SHOULD BE EMPLOYED.
 5. REFER TO SMARTPLATE APPLICATIONS GUIDE, SP-1010, TO DETERMINE IF SYSTEM REQUIRES A BUFFER TANK.
 6. INSTALL A HOSE CONNECTION AT THE HOT WATER OUTLET.

 INTERNATIONAL, INC. <small>Blauvelt, NY 10913</small>	
SMARTPLATE WATER TO WATER HEAT EXCHANGER MULTIPLE UNITS W/ ACCUMULATOR TANK	
DWN. BY <u> </u> K.S. DATE <u>010713</u>	REV. <u> </u>
SCALE <u> </u> APPD. <u> </u> DATE <u> </u>	SD-A-777 C

Drawing Number: SD-A-777 rev C

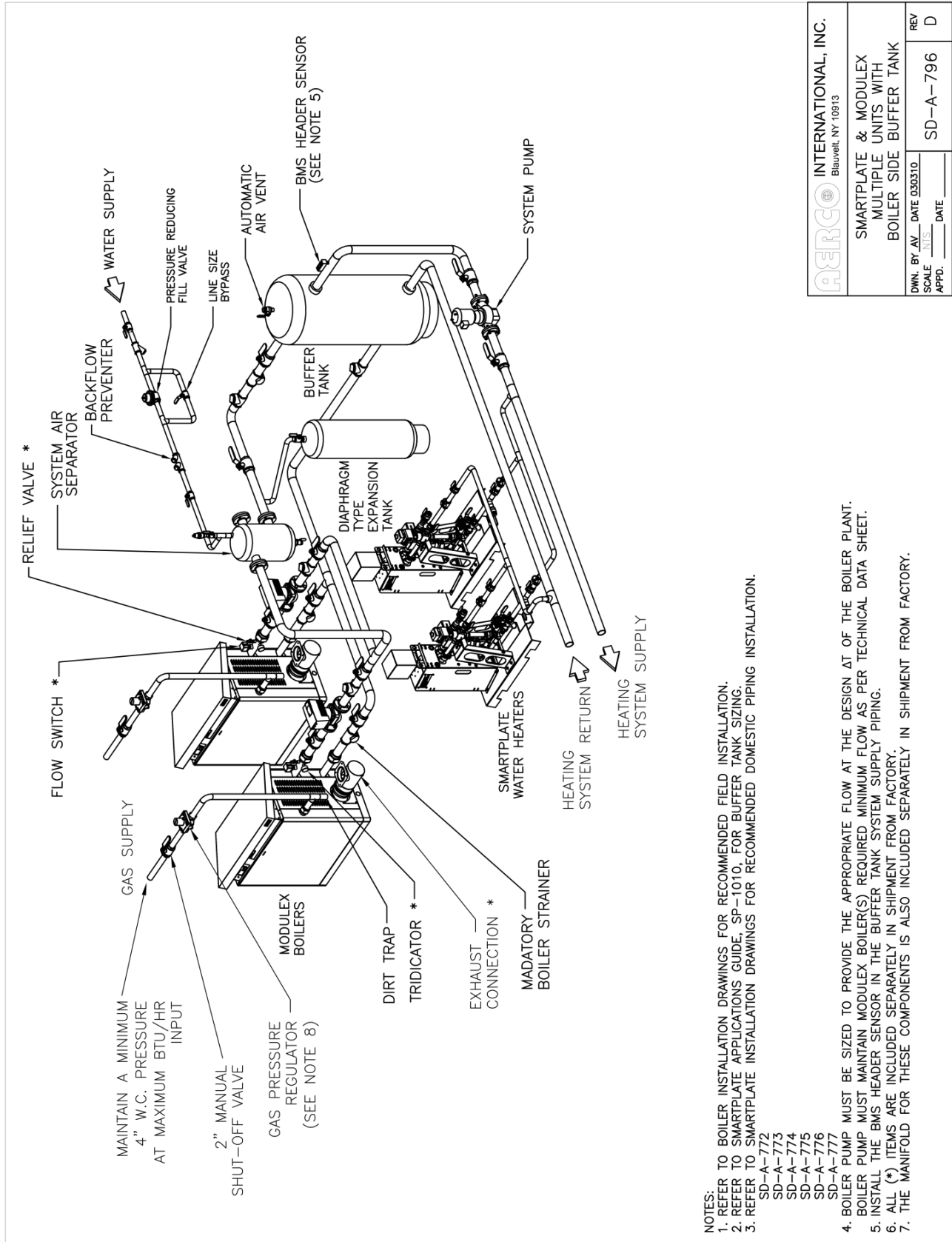

AERCO INTERNATIONAL, INC. <small>Blauvelt, NY 10913</small>	
SMARTPLATE & MODULEX MULTIPLE UNITS WITH BOILER SIDE BUFFER TANK	
DWN. BY: AV DATE 03/03/10	REV D
APPD. _____ DATE _____	SD-A-796

- NOTES:**
1. REFER TO BOILER INSTALLATION DRAWINGS FOR RECOMMENDED FIELD INSTALLATION.
 2. REFER TO SMARTPLATE APPLICATIONS GUIDE, SP-1010, FOR BUFFER TANK SIZING.
 3. REFER TO SMARTPLATE INSTALLATION DRAWINGS FOR RECOMMENDED DOMESTIC PIPING INSTALLATION.
SD-A-772
SD-A-773
SD-A-774
SD-A-775
SD-A-776
SD-A-777
 4. BOILER PUMP MUST BE SIZED TO PROVIDE THE APPROPRIATE FLOW AT THE DESIGN AT OF THE BOILER PLANT.
 5. BOILER PUMP MUST MAINTAIN MODULEX BOILER(S) REQUIRED MINIMUM FLOW AS PER TECHNICAL DATA SHEET.
 6. INSTALL THE BMS HEADER SENSOR IN THE BUFFER TANK SYSTEM SUPPLY PIPING.
 7. ALL (*) ITEMS ARE INCLUDED SEPARATELY IN SHIPMENT FROM FACTORY.
 8. THE MANIFOLD FOR THESE COMPONENTS IS ALSO INCLUDED SEPARATELY IN SHIPMENT FROM FACTORY.

Drawing Number: SD-A-796 rev D

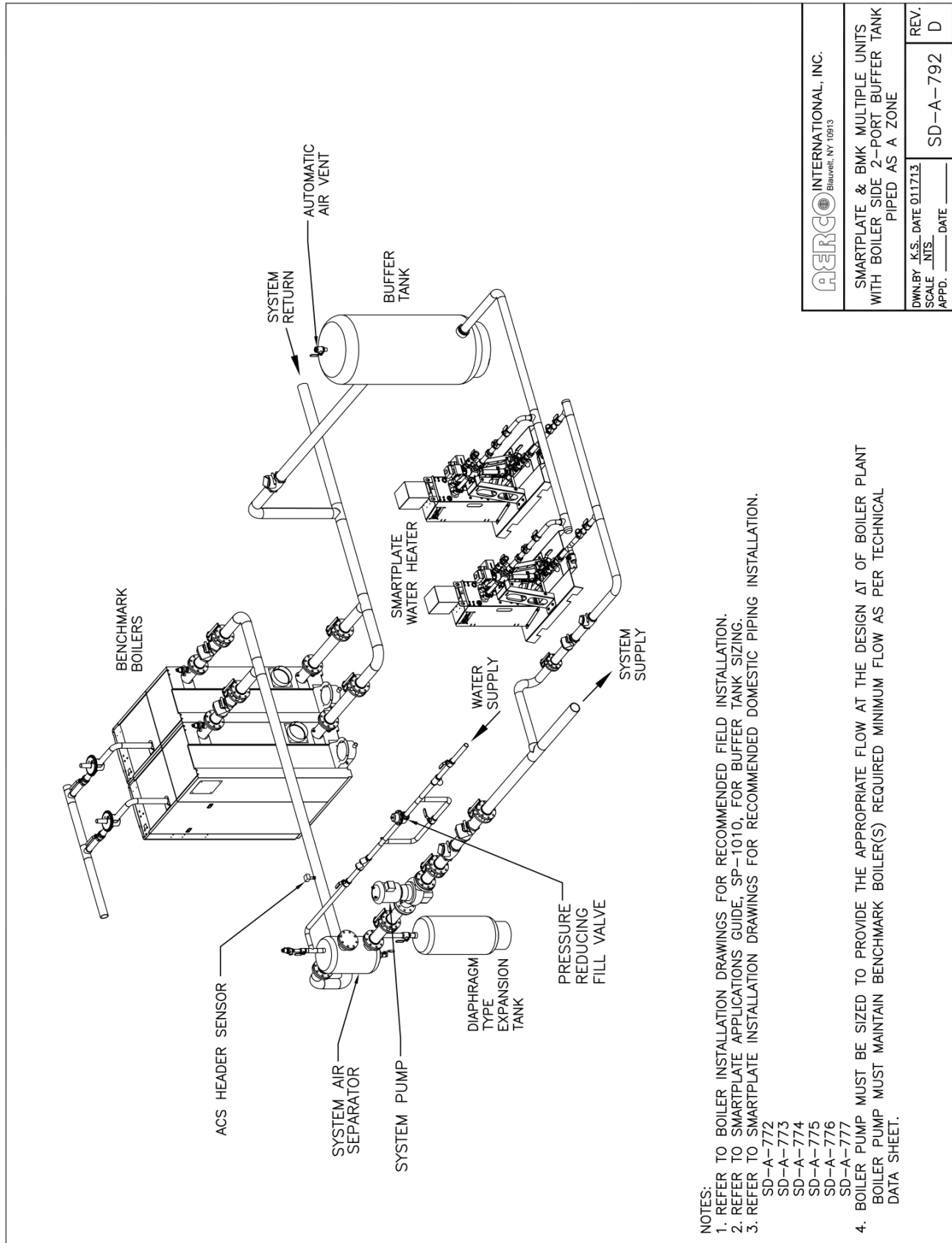

AERCO INTERNATIONAL, INC. <small>Blauvelt, NY 10913</small>	
SMARTPLATE & BMK MULTIPLE UNITS WITH BOILER SIDE 2-PORT BUFFER TANK PIPED AS A ZONE	
DWN. BY	K.S. DATE 011713
SCALE	NTS
APPD.	DATE
REV.	SD-A-792
	D

- NOTES:
1. REFER TO BOILER INSTALLATION DRAWINGS FOR RECOMMENDED FIELD INSTALLATION.
 2. REFER TO SMARTPLATE APPLICATIONS GUIDE, SP-1010, FOR BUFFER TANK SIZING.
 3. REFER TO SMARTPLATE INSTALLATION DRAWINGS FOR RECOMMENDED DOMESTIC PIPING INSTALLATION.
SD-A-772
SD-A-773
SD-A-774
SD-A-775
SD-A-776
SD-A-777
 4. BOILER PUMP MUST BE SIZED TO PROVIDE THE APPROPRIATE FLOW AT THE DESIGN ΔT OF BOILER PLANT
BOILER PUMP MUST MAINTAIN BENCHMARK BOILER(S) REQUIRED MINIMUM FLOW AS PER TECHNICAL
DATA SHEET.

Drawing Number: SD-A-792 rev D

APPENDIX D – SMARTPLATE PIPING DRAWINGS

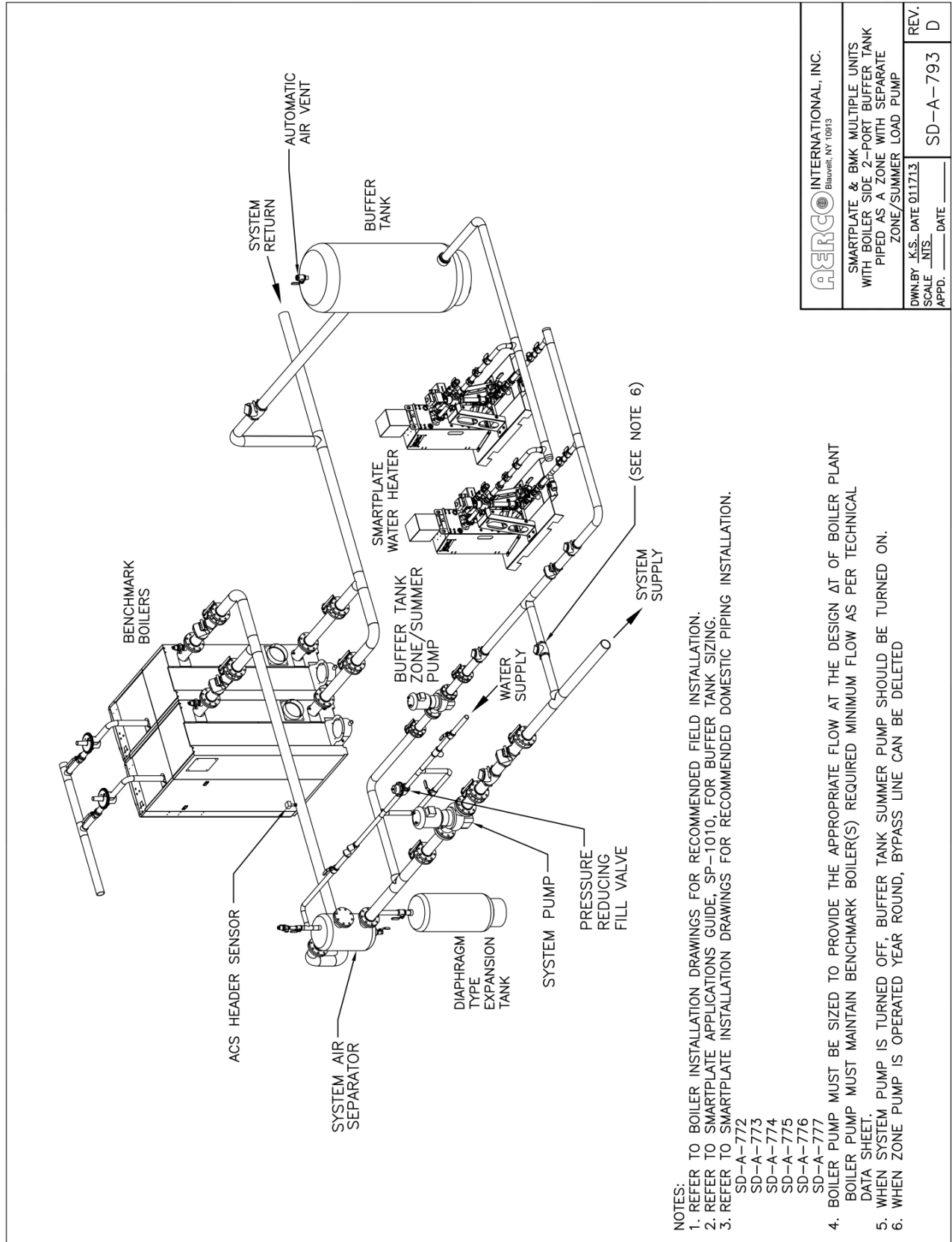

 AERCO INTERNATIONAL, INC. <small>Elmwood, NY 10813</small>	
SMARTPLATE & BMK MULTIPLE UNITS WITH BOILER SIDE 2-PORT BUFFER TANK PIPED AS A ZONE WITH SEPARATE ZONE/SUMMER LOAD PUMP	
DWN.BY: K.S. DATE 011713 SCALE: NIS. DATE _____ APPD. _____	REV.: SD-A-793 D

- NOTES:
1. REFER TO BOILER INSTALLATION DRAWINGS FOR RECOMMENDED FIELD INSTALLATION.
 2. REFER TO SMARTPLATE APPLICATIONS GUIDE, SP-1010, FOR BUFFER TANK SIZING.
 3. REFER TO SMARTPLATE INSTALLATION DRAWINGS FOR RECOMMENDED DOMESTIC PIPING INSTALLATION.
 SD-A-772
 SD-A-773
 SD-A-774
 SD-A-775
 SD-A-776
 SD-A-777
 4. BOILER PUMP MUST BE SIZED TO PROVIDE THE APPROPRIATE FLOW AT THE DESIGN AT OF BOILER PLANT
 BOILER PUMP MUST MAINTAIN BENCHMARK BOILER(S) REQUIRED MINIMUM FLOW AS PER TECHNICAL
 DATA SHEET.
 5. WHEN SYSTEM PUMP IS TURNED OFF, BUFFER TANK SUMMER PUMP SHOULD BE TURNED ON.
 6. WHEN ZONE PUMP IS OPERATED YEAR ROUND, BYPASS LINE CAN BE DELETED

Drawing Number: SD-A-793 rev D

APPENDIX D – SMARTPLATE PIPING DRAWINGS

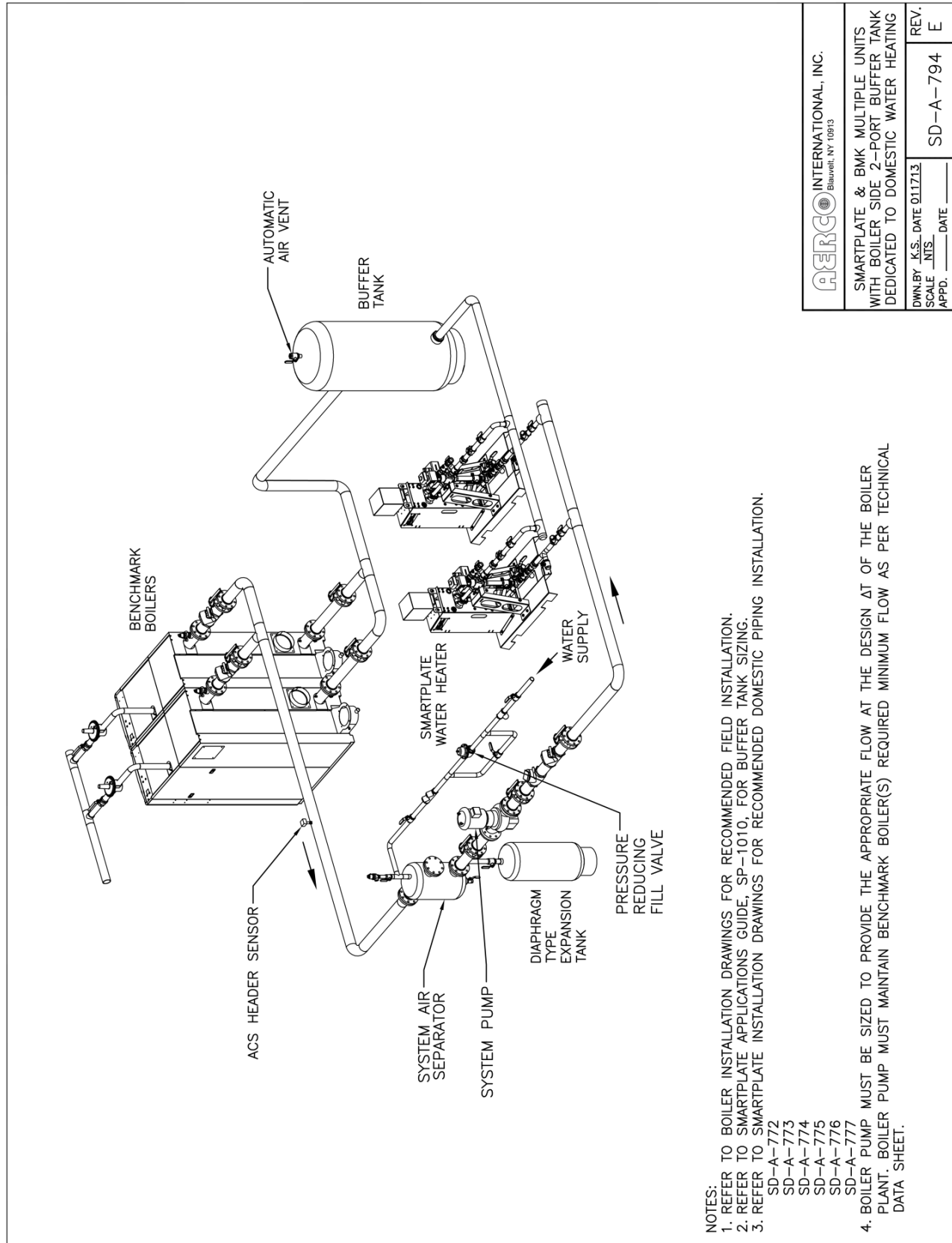

AERCO <small>Blauvelt, NY 10913</small>	
INTERNATIONAL, INC.	
SMARTPLATE & BMK MULTIPLE UNITS WITH BOILER SIDE 2-PORT BUFFER TANK DEDICATED TO DOMESTIC WATER HEATING	
DWN. BY SCALE	DATE DATE
APPD.	REV.
SD-A-794	E

- NOTES:
1. REFER TO BOILER INSTALLATION DRAWINGS FOR RECOMMENDED FIELD INSTALLATION.
 2. REFER TO SMARTPLATE APPLICATIONS GUIDE, SP-1010, FOR BUFFER TANK SIZING.
 3. REFER TO SMARTPLATE INSTALLATION DRAWINGS FOR RECOMMENDED DOMESTIC PIPING INSTALLATION.
SD-A-772
SD-A-773
SD-A-774
SD-A-775
SD-A-776
SD-A-777
 4. BOILER PUMP MUST BE SIZED TO PROVIDE THE APPROPRIATE FLOW AT THE DESIGN ΔT OF THE BOILER PLANT. BOILER PUMP MUST MAINTAIN BENCHMARK BOILER(S) REQUIRED MINIMUM FLOW AS PER TECHNICAL DATA SHEET.

Drawing Number: SD-A-794 rev E

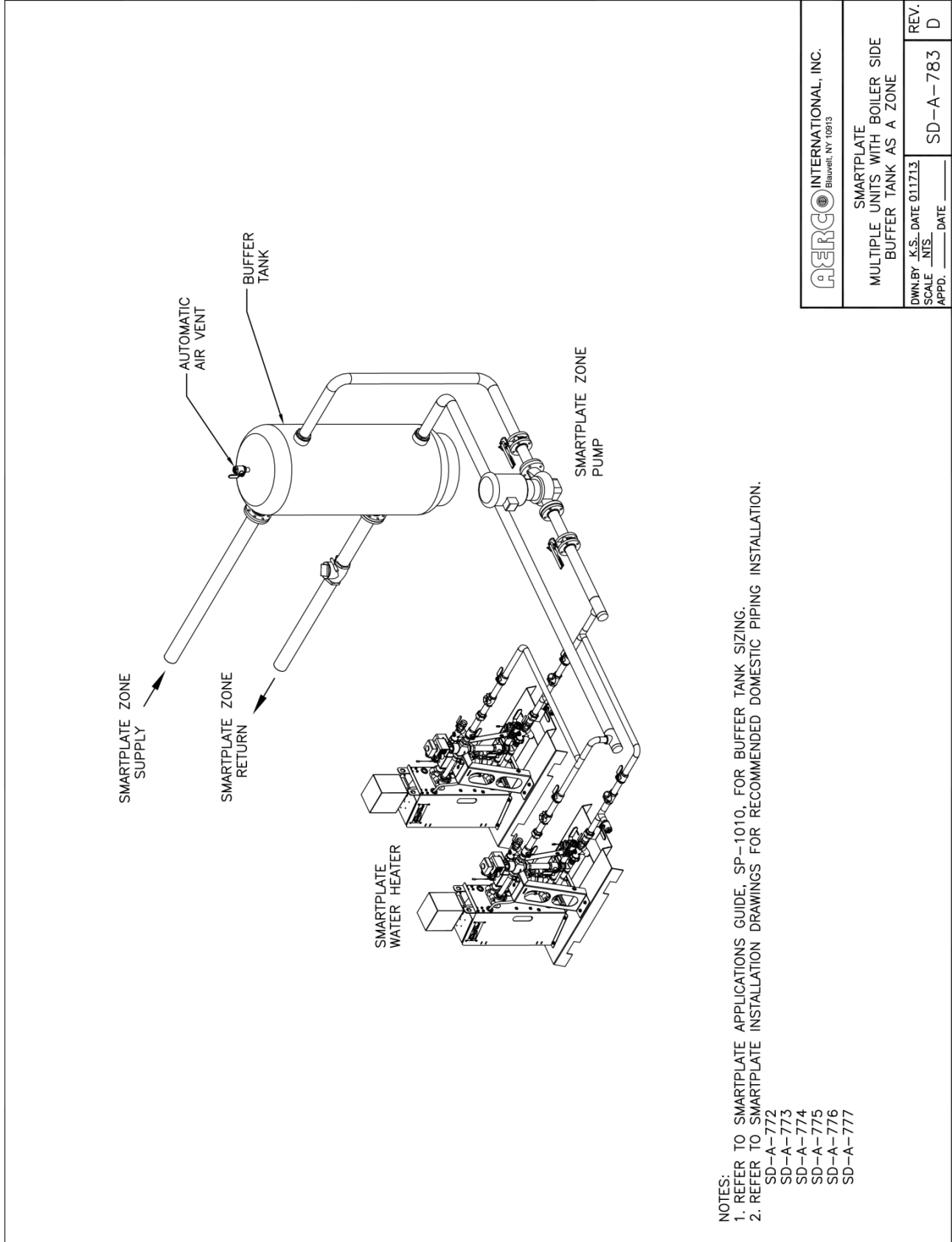

- NOTES:
 1. REFER TO SMARTPLATE APPLICATIONS GUIDE, SP-1010, FOR BUFFER TANK SIZING.
 2. REFER TO SMARTPLATE INSTALLATION DRAWINGS FOR RECOMMENDED DOMESTIC PIPING INSTALLATION.
 SD-A-772
 SD-A-773
 SD-A-774
 SD-A-775
 SD-A-776
 SD-A-777

AERCO <small>Blauvelt, NY 10813</small>	
SMARTPLATE MULTIPLE UNITS WITH BOILER SIDE BUFFER TANK AS A ZONE	
DWN. BY: <u> </u> K.S. DATE 011713	REV. <u> </u> D
SCALE: <u> </u> IN/S. DATE <u> </u>	APPD. <u> </u> SD-A-783

Drawing Number: SD-A-783 rev D

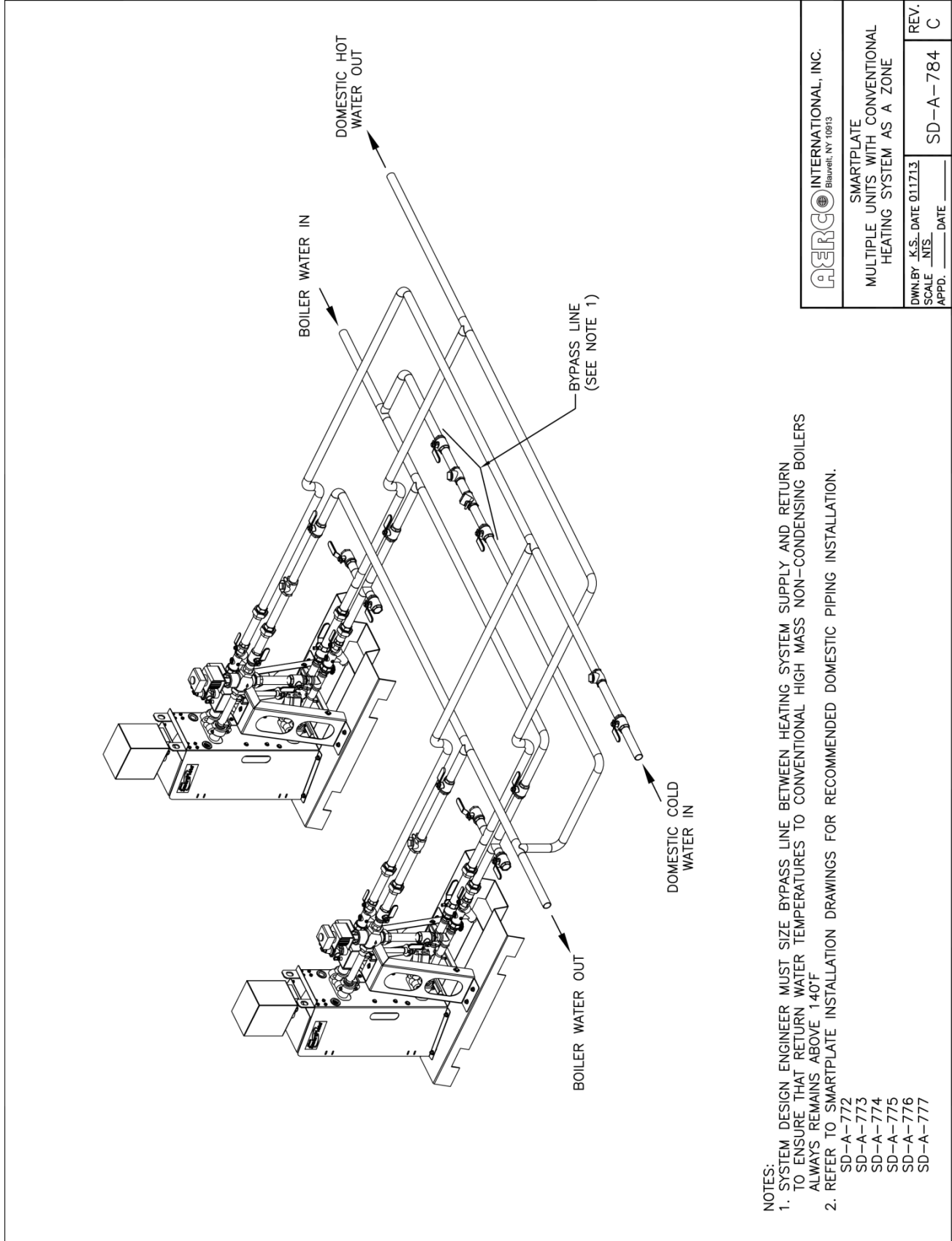

- NOTES:
1. SYSTEM DESIGN ENGINEER MUST SIZE BYPASS LINE BETWEEN HEATING SYSTEM SUPPLY AND RETURN TO ENSURE THAT RETURN WATER TEMPERATURES TO CONVENTIONAL HIGH MASS NON-CONDENSING BOILERS ALWAYS REMAINS ABOVE 140°F
 2. REFER TO SMARTPLATE INSTALLATION DRAWINGS FOR RECOMMENDED DOMESTIC PIPING INSTALLATION.

SD-A-772
 SD-A-773
 SD-A-774
 SD-A-775
 SD-A-776
 SD-A-777

AERCO INTERNATIONAL, INC. <small>Bauveit, NY 10913</small>	
SMARTPLATE MULTIPLE UNITS WITH CONVENTIONAL HEATING SYSTEM AS A ZONE	
DOWN BY K.S. DATE 011713 SCALE NIS	REV. C SD-A-784
APPD. _____ DATE _____	

Drawing Number: SD-A-784 rev C

APPENDIX E – DIMENSIONAL DRAWINGS

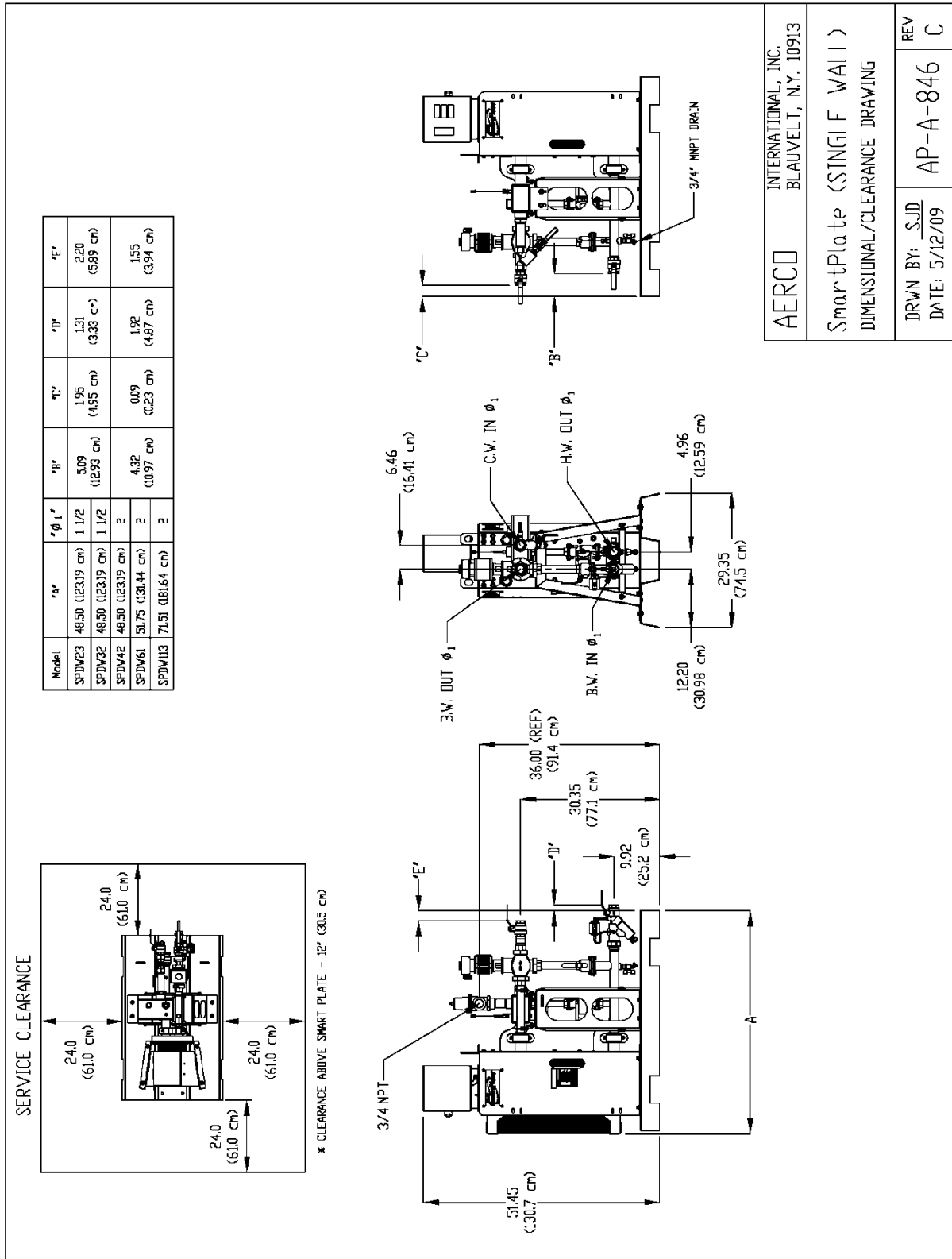

Drawing Number: AP-A-846 rev C

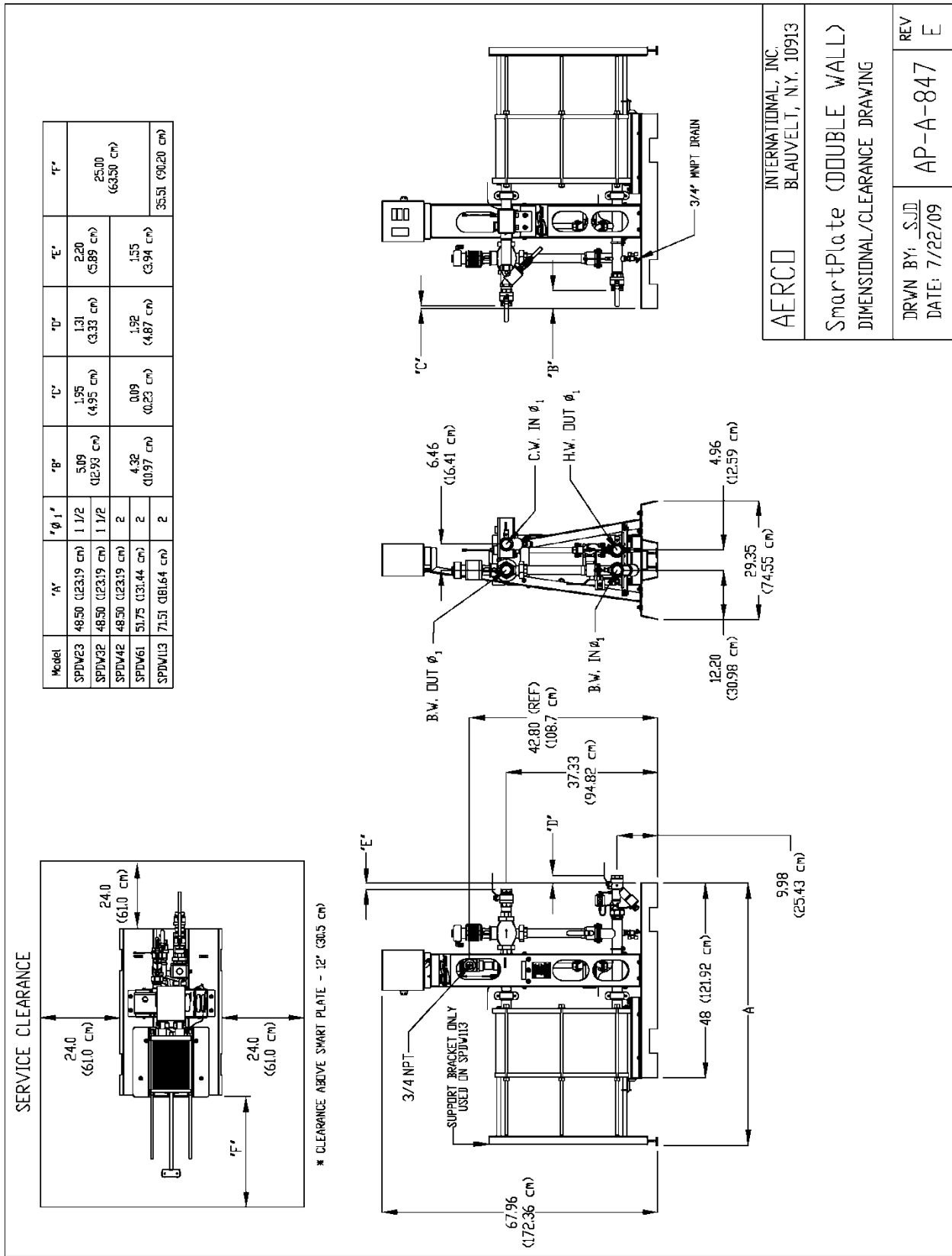

AERCO	INTERNATIONAL, INC. BLAUVELT, N.Y. 10913
SmartPlate (DOUBLE WALL) DIMENSIONAL/CLEARANCE DRAWING	
DRWN BY: <u>SJD</u>	REV E
DATE: 7/22/09	AP-A-847

APPENDIX F – PART LISTS

SmartPlate SINGLE WALL – Base Components			
Item #	Qty	Part #	Description
1	1	34026	BASE: SMARTPLATE
2	1	SEE TABLE	BRAZED PLATE HEAT EXCHANGER
3-A	1	SEE TABLE	PIPING ASSY, 1.5" 120V 60 Hz (See assembly drawings below)
3-B			PIPING ASSY, 1.5" 220V 50 Hz (See assembly drawings below)
3-C			PIPING ASSY, 1.5" 220V 60 Hz (See assembly drawings below)
4-A	1	SEE TABLE	PIPING ASSY, 2" 120V/60 Hz (See assembly drawings below)
4-B			PIPING ASSY, 2" 220V/50 Hz (See assembly drawings below)
4-C			PIPING ASSY, 2" 220V/60 Hz (See assembly drawings below)
5	1	24198	SUPPORT BRACKET ASSEMBLY, BRAZED HEAT EXCHANGER
6	1	35015	SUPPORT A-FRAME, SMARTPLATE
7	1	33084-1	BRACKET UPPER PIPES
8	2	33084-2	ADJUSTER PIPE SUPPORT
9	1	33083	BRACKET, MIXING BOX
10	2	33085	BRACKET LOWER PIPES SUPPORT
20	1	33086	SUPPORT CONTROL BOX
22	1	73072	PLATE, RATING
31	1	69096	CONTROL BOX ASSY, SMARTPLATE

Description		Item 2	Item 3-A	Item 3-B	Item 3-C	Item 4-A	Item 4-B	Item 4-C
SP-23	120V 60 Hz	28121-1	22263-1					
	220V 50 Hz			22263-3				
	220V 60 Hz				22263-5			
SP-33	120V 60 Hz	28121-2	22263-1					
	220V 50 Hz			22263-3				
	220V 60 Hz				22263-5			
SP-45	120V 60 Hz	28121-3				22264-1		
	220V 50 Hz						22264-3	
	220V 60 Hz							22264-5
SP-69	120V 60 Hz	28121-4				22264-1		
	220V 50 Hz						22264-3	
	220V 60 Hz							22264-5
SP-150	120V 60 Hz	28121-5				22264-1		
	220V 50 Hz						22264-3	
	220V 60 Hz							22264-5

AERCO International, Inc. Blauvelt, NY 10913	SmartPlate Single Wall Part List	02/27/2017
	29381-TAB rev F	Sheet 1 of 2

APPENDIX E – PART LISTS

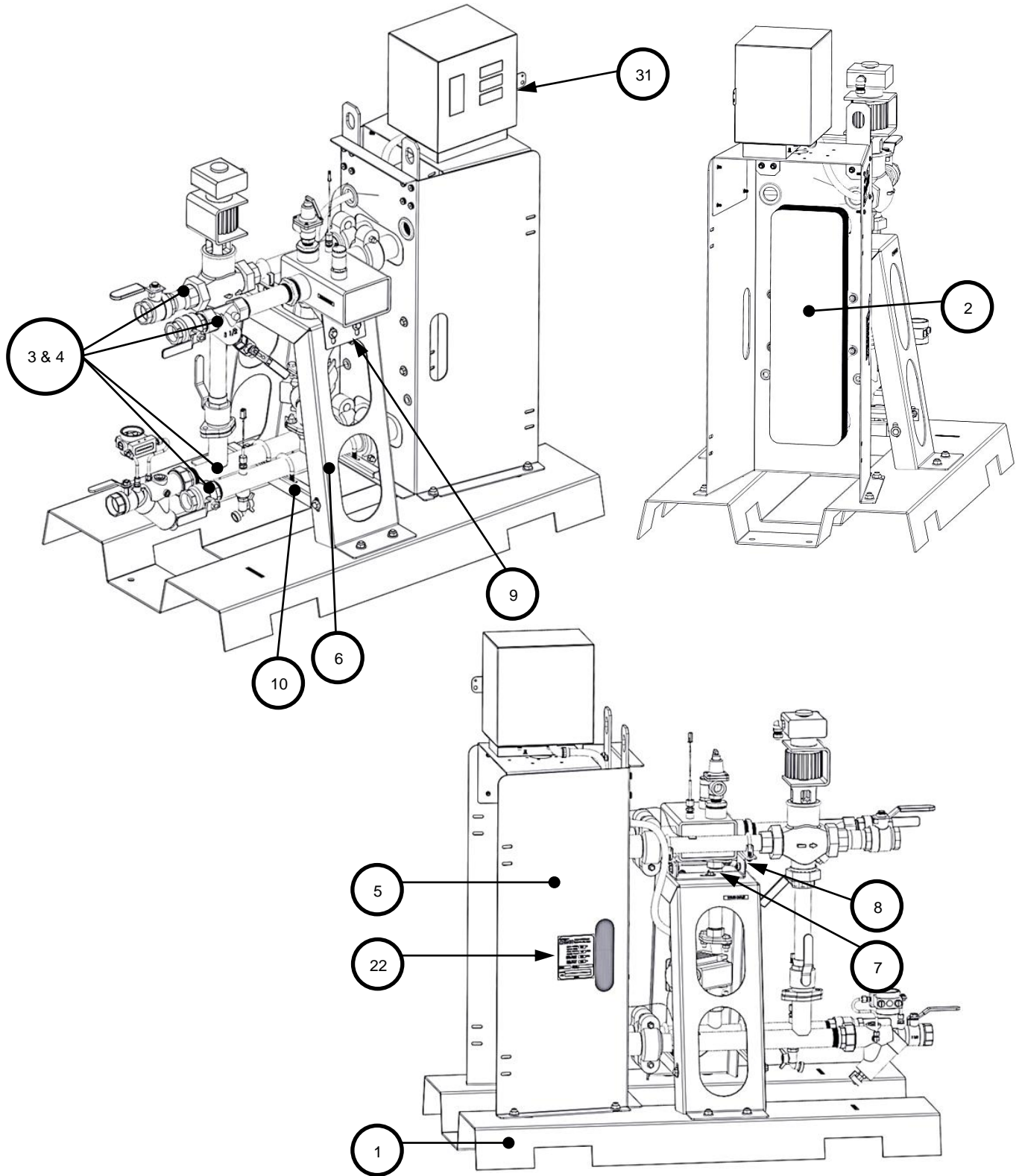

AERCO International, Inc. Blauvelt, NY 10913	<p align="center">SmartPlate Single Wall Part List</p> <p align="center">29381-TAB rev F</p>	02/27/2017 Sheet 2 of 2
--	--	--------------------------------

APPENDIX E – PART LISTS

SmartPlate DOUBLE-WALL – Base Components			
Item #	Qty	Part #	Description
1	1	SEE TABLE	DOUBLE WALL HEAT EXCHANGER
2	1	34026	BASE, SMARTPLATE
3-A	1	SEE TABLE	PIPING ASSY, 1.5" SPDW – 120V/60 Hz
3-B			PIPING ASSY, 1.5" SPDW – 220V/50 Hz
4-A	1	SEE TABLE	PIPING ASSY, 2" SPDW – 120V/60 Hz
4-B			PIPING ASSY, 2" SPDW – 220V/50 Hz
5	1	33102	BRACKET, MIXING BOX DW
6	2	33105	BRACKET LOWER PIPES SUPPORT
7	1	33091	HX MOUNT, SMARTPLATE DW
8	1	SEE TABLE	DW HX END SUPPORT BRACKET (Not Shown Below)
9	1	33098	PIPING FRAME, LEFT, SMARTPLATE DW
10	1	33099	PIPING FRAME, RIGHT, SMARTPLATE DW
12	1	69096	CONTROL BOX ASSY, SMARTPLATE
18	1	73072	PLATE, RATING
20	1	33106	BRACKET, ADJUSTER PIPING SUPPORT

Pressure	Description		Item 1	Item 3-A	Item 3-B	Item 4-A	Item 4-B	Item 8
150 PSI Pressure	SPDW-23	120V 60 Hz	28104-1	22263-2				
		220V 50 Hz			22263-4			
	SPDW-32	120V 60 Hz	28104-2	22263-2				
		220V 50 Hz			22263-4			
	SPDW-42	120V 60 Hz	28104-3			22264-2		
		220V 50 Hz				22264-4		
	SPDW-61	120V 60 Hz	28104-4			22264-2		
		220V 50 Hz				22264-4		
	SPDW-113	120V 60 Hz	28104-5			22264-2		33095
		220V 50 Hz				22264-4		33095
200 PSI Pressure	SPDW-23	120V 60 Hz	28104-6	22263-2				
		220V 50 Hz			22263-4			
	SPDW-32	120V 60 Hz	28104-7	22263-2				
		220V 50 Hz			22263-4			
	SPDW-42	120V 60 Hz	28104-8			22264-2		
		220V 50 Hz				22264-4		
	SPDW-61	120V 60 Hz	28104-9			22264-2		
		220V 50 Hz				22264-4		
	SPDW-113	120V 60 Hz	28104-10			22264-2		33095
		220V 50 Hz				22264-4		33095

AERCO International, Inc. Blauvelt, NY 10913	SmartPlate Double Wall Part List	02/22/2017
	29382-TAB rev E	Sheet 1 of 2

APPENDIX E – PART LISTS

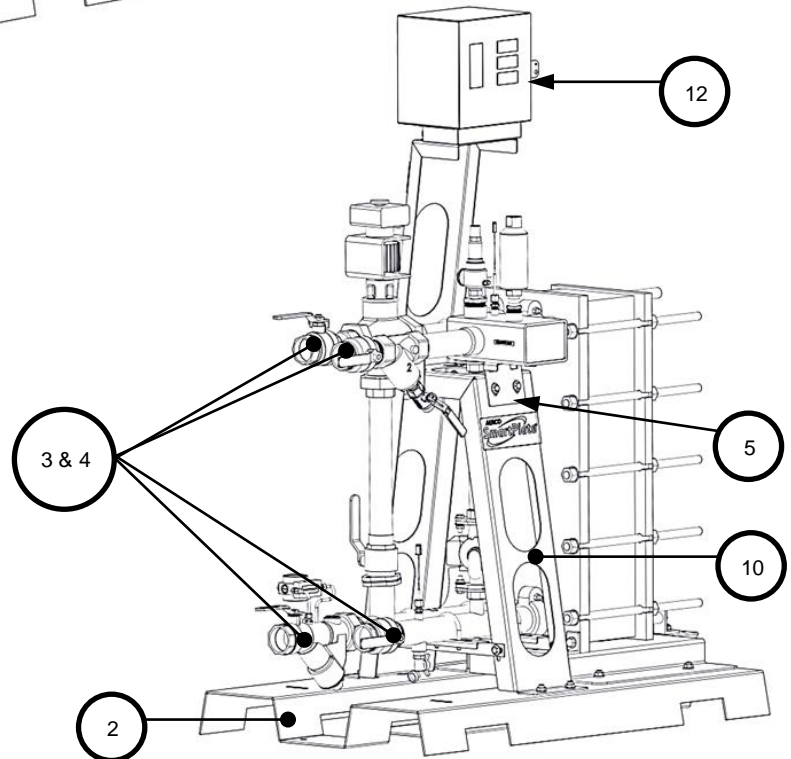
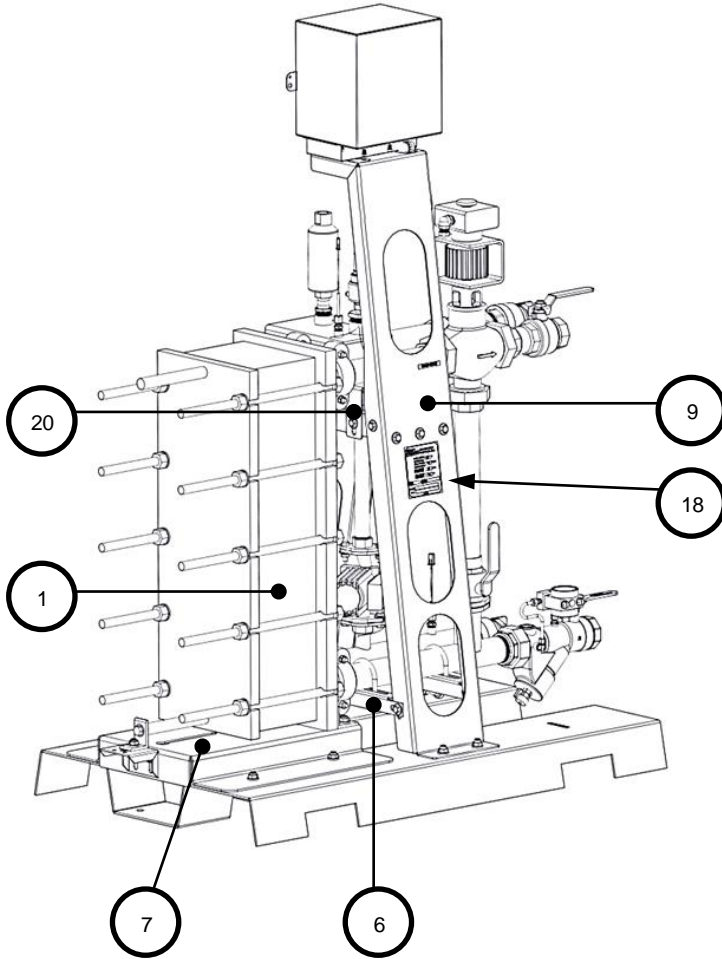

AERCO International, Inc. Blauvelt, NY 10913	SmartPlate Double Wall Part List	02/22/2017
	29382-TAB rev E	Sheet 2 of 2

APPENDIX E – PART LISTS

SmartPlate Installation Kits

SmartPlate Water Heater units are shipped with one of the following installation kits:

Kit #	SmartPlate Models	HX Type	Pressure	NYC Option	
58128-1	SP23, SP33, SP45, SP69, SP150	Single Wall	150 PSI	No	
	SPDW23, SPDW32, SPDW42, SPDW61, SPDW113	Double Wall			
58128-2	SP23, SP33, SP45, SP69, SP150	Single Wall	200 PSI		
	SPDW23, SPDW32, SPDW42, SPDW61, SPDW113	Double Wall			
58128-3	SP23, SP33, SPDW23, SPDW32	Double Wall	150 PSI		Yes
58128-4	SP45, SP69, SP150, SPDW42, SPDW61, SPDW113	Double Wall			
58128-5	SP23, SP33, SPDW23, SPDW32	Double Wall	200 PSI		
58128-6	SP45, SP69, SP150, SPDW42, SPDW61, SPDW113	Double Wall			

The contents of each kit are shown in the table below.

Part #	Description	Quantity Per Kit					
		150 PSI Kits			200 PSI Kits		
		58128-1	58128-3	58128-4	58128-2	58128-5	58128-6
92070	Air Vent Valve ¾", 150 PSI	1	1	1			
92130	Air Vent Valve ¾", 200 PSI				1	1	1
92065-1	Relief Valve, ¾M X ¾F, 150 PSI	1	1	1			
92134-1	Relief Valve, 200 PSI				1	1	1
92111	Relief Valve (NYC Only)		1	1		1	1
93521	Reducing Bushing, 1 ½" to ¾"	1	1	1	1	1	1
93505	Reducing Bushing 1" to ¾"			1	1	1	2
93451	Nipple, ¾", 2" Lg., 200 PSI				1	1	1

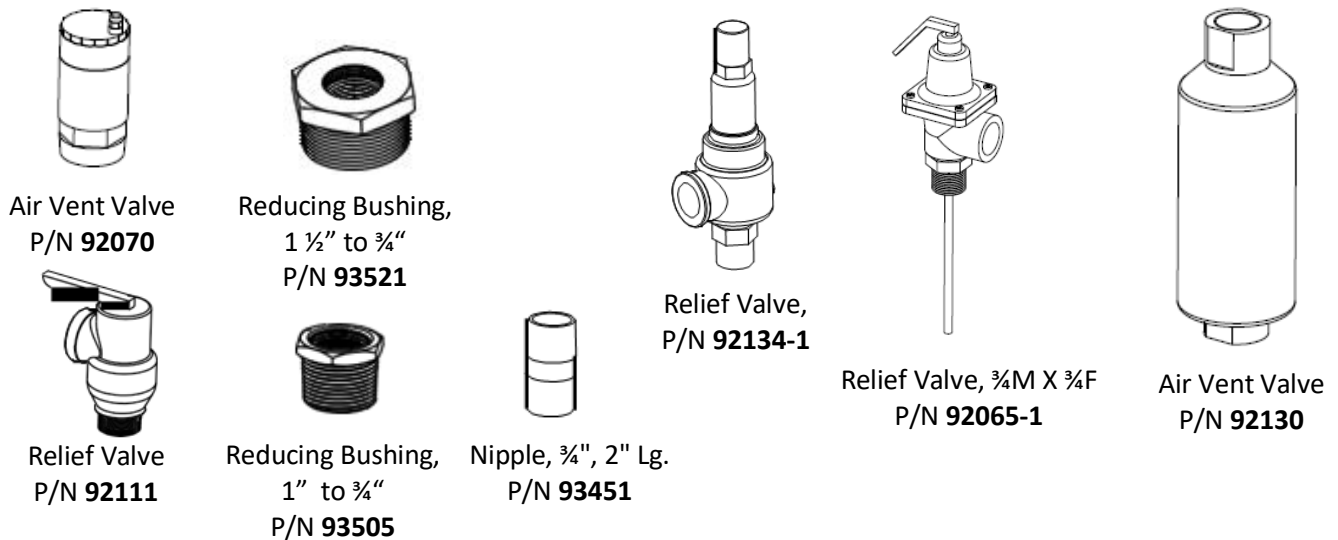

AERCO International, Inc. Blauvelt, NY 10913	SmartPlate Accessory Kits	11/15/2016
	58128-TAB rev D	Sheet 1 of 1

APPENDIX E – PART LISTS

P/N 22263-TAB – SmartPlate 1.5 " Piping Assemblies

1.5 inch piping assemblies are used in the following SmartPlate models:

Piping Assembly P/N	SmartPlate Models	Pressure *	Type	Power
22263-1	SP23, SP33	150 PSI & 200 PSI	Single Wall	120V 60 Hz
22263-2	SPDW23, SPDW32	150 PSI & 200 PSI	Double Wall	
22263-3	SP23, SP33	150 PSI & 200 PSI	Single Wall	220V 50 Hz
22263-4	SPDW23, SPDW32	150 PSI & 200 PSI	Double Wall	

* Appropriate add-on kit differentiates overall product for given DHW side operating pressure

The table below lists the parts and quantities in each piping assembly:

ITEM NO.	PART NUMBER	DESCRIPTION	22263-1 QTY	22263-2 QTY	22263-3 QTY	22263-4 QTY	22263-5 QTY
1	93159	COUPLING, QUIK FLEX 2"	4	4	4	4	4
2	9-234	CLOSE NIPPLE, 3/4" NPT SCH. 40 RED BRASS	1	1	1	1	1
3	81238	RING GASKET, 3-PLY, 1"	2	2	2	2	2
4	93413	CLOSE NIPPLE, SS SCH 40, 1.5" NPT	1	1	1	1	1
5	12610-9-8	BUSHING, HEX RED. 2" X 1 1/2"	1	1	1	1	1
6	90058	1-1/2" NPT NIPPLE X 7" LG	1	1	1	1	1
7	92060	VALVE, 3/4" DRAIN MNPT X GHT	1	1	1	1	1
8	6-311	BOLT, HEX 3/8-16 X 1.00 LG	2	2	2	2	2
9	123614	WASHER, FLAT 3/8	4	6	6	6	6
10	93029	1/4" MNPT x 3/16" OD COMPRESSION FITTING	2	2	2	2	2
11	41023	MANIFOLD, INTAKE	1	1	1	1	1
12	92128	FULL BALL PORT VALVE, 3/4" NPT x 3/4" HOSE	1	1	1	1	1
13	61009-1	THERMOCOUPLE, SINGLE ELEMENT	1	1	1	1	1
14	69259-1	CARTRIDGE CIRCULATOR, 110V 60Hz, 200 PSI	1	1	-	-	-
14	69259-2	CARTRIDGE CIRCULATOR, 220V 50Hz, 200 PSI	-	-	1	1	-
14	69259-3	CARTRIDGE CIRCULATOR, 220V 60Hz, 200 PSI	-	-	-	-	1
15	61008-1	THERMOCOUPLE, DUAL ELEMENT	1	1	1	1	1
16	22101-2	1.5" 3-WAY VALVE ASSY W/ LEFT LEG	1	1	1	1	1
17	22251-2	MANIFOLD, DHW 1.5" NPT	1	1	1	1	1
18	22255-1	SPOOL PIECE, 1" PIPE X FREEDOM FLGS. 8.40 LG	1	-	1	-	1
18	22255-2	SPOOL PIECE, 1" PIPE X FREEDOM FLGS. 15.28 LG	-	1	-	1	-
19	22260-4	SPOOL PIECE w/VALVE, 1.5" TUBE, 12.5" LG	1	-	1	-	1
19	22260-2	SPOOL PIECE w/VALVE, 1.5" TUBE, 19.45" LG	-	1	-	1	-
20	90047-3	PIPE NIPPLE, SS SCH. 40, TBE, 1.5" X 3" LG.	1	1	1	1	1
21	22272-1.5	BALL VALVE & STRAINER COMBO w/	1	1	1	1	1
22	93514-1.5	STRAINER 1.5"NPT, WYE-PATTERN, LEAD FREE BRONZE	1	1	1	1	1
23	22262	MANIFOLD, 1.5" NPT BOILER SIDE	1	1	1	1	1
24	92106	BALL VALVE, 1.5" NPT LEAD FREE	3	3	3	3	3

AERCO International, Inc. Blauvelt, NY 10913	SmartPlate 1.5" Piping Assembly	1/22/2020
	22263-TAB rev E	Sheet 1 of 2

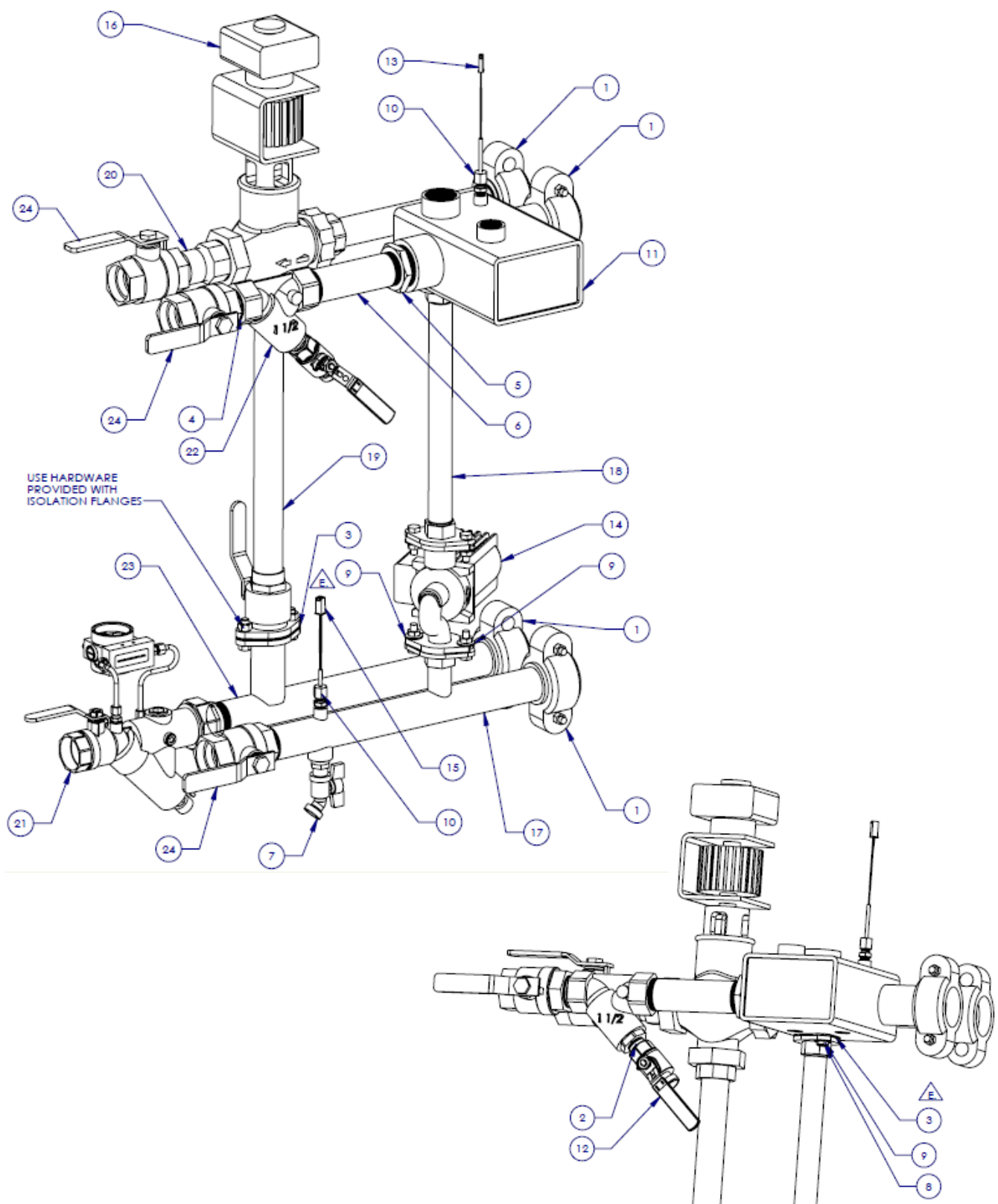

AERCO International, Inc. Blauvelt, NY 10913	SmartPlate 1.5" Piping Assembly	1/22/2020
	22263-TAB rev E	Sheet 2 of 2

APPENDIX E – PART LISTS

P/N 22264-TAB – SmartPlate 2.0 " Piping Assemblies

2.0 inch piping assemblies are used in the following SmartPlate models:

Piping Assy. P/N	SmartPlate Models	Pressure *	Type	Power
22264-1	SP45, SP69, SP150	150 PSI & 200 PSI	Single Wall	120V 60 Hz
22264-2	SPDW42, SPDW61, SPDW113	150 PSI & 200 PSI	Double Wall	
22264-3	SP45, SP69, SP150	150 PSI & 200 PSI	Single Wall	220V 50 Hz
22264-4	SPDW42, SPDW61, SPDW113	150 PSI & 200 PSI	Double Wall	
22264-5	SPDW42, SPDW61, SPDW113	200 PSI	Double Wall	220V 60 Hz

* Appropriate add-on kit differentiates overall product for given DHW side operating pressure

The table below lists the parts and quantities in each piping assembly:

ITEM NO.	PART NUMBER	DESCRIPTION	22264-1 QTY	22264-2 QTY	22264-3 QTY	22264-4 QTY	22264-5 QTY
1	93159	COUPLING, QUIK FLEX 2"	4	4	4	4	4
2	90046-3	NIPPLE, 2" NPT 304 SS SCH 40, 3" LG	1	1	1	1	1
3	22272-2	BALL VALVE & STRAINER COMBO, 2" NPT w/ DP GAGE	1	1	1	1	1
4	41023	MANIFOLD, INTAKE	1	1	1	1	1
5	61009-1	THERMOCOUPLE, SINGLE ELEMENT	1	1	1	1	1
6	81238	RING GASKET, 3-PLY, 1"	1	1	1	1	1
7	93029	1/4" MNPT x 3/16" OD COMPRESSION FITTING	2	2	2	2	2
8	123614	WASHER, FLAT 3/8	6	6	6	6	6
9	6-311	BOLT, HEX 3/8-16 X 1.00 LG	2	2	2	2	2
10	69259-3	CARTRIDGE CIRCULATOR, 220V 60Hz, 200 PSI	-	-	-	-	1
11	92060	VALVE, 3/4" DRAIN MNPT X GHT	1	1	1	1	1
12	61008-1	THERMOCOUPLE, DUAL ELEMENT	1	1	1	1	1
13	22101-1	2" 3-WAY VALVE ASSY W/ LEFT LEG	1	1	1	1	1
14	90046-8	NIPPLE, 2" NPT 304 SS SCH 40, 8" LG	1	1	1	1	1
15	93514-2	STRAINER 2"NPT, WYE-PATTERN, LEAD FREE BRONZE	1	1	1	1	1
16	90106	CLOSE NIPPLE, 2" NPT SS, SCH 40	1	1	1	1	1
17	22251-1	MANIFOLD, DHW 2" NPT	1	1	1	1	1
18	22255-1	SPOOL PIECE, 1" PIPE X FREEDOM FLGS. 8.40 LG	1	-	1	-	1
19	22261	MANIFOLD, 2" NPT BOILER SIDE	1	1	1	1	1
20	22260-3	SPOOL PIECE w/VALVE, 2" TUBE, 12"LG	1	-	1	-	1
21	92107	BALL VALVE, 2" NPT LEAD FREE	3	3	3	3	3
22	81239	GASKET, 3-PY, 2"	1	1	1	1	1
23	93505	HEX REDUCING BUSHING, 1" MNPT x 3/4" FNPT	1	1	1	1	1
24	92128	FULL BALL PORT VALVE, 3/4" NPT x 3/4" HOSE	1	1	1	1	1
25	9-234	CLOSE NIPPLE, 3/4" NPT SCH. 40 RED BRASS	1	1	1	1	1
26	69259-1	CARTRIDGE CIRCULATOR, 110V 60Hz, 200 PSI	1	1	-	-	-
27	69259-2	CARTRIDGE CIRCULATOR, 220V 50Hz, 200 PSI	-	-	1	1	-
28	22255-2	SPOOL PIECE, 1" PIPE X FREEDOM FLGS. 15.28 LG	-	1	-	1	-
29	22260-1	SPOOL PIECE w/VALVE, 2" TUBE, 18.90"LG	-	1	-	1	-

AERCO International, Inc. Blauvelt, NY 10913	SmartPlate 2.0" Piping Assembly	1/22/2020
	22264-TAB rev E	Sheet 1 of 2

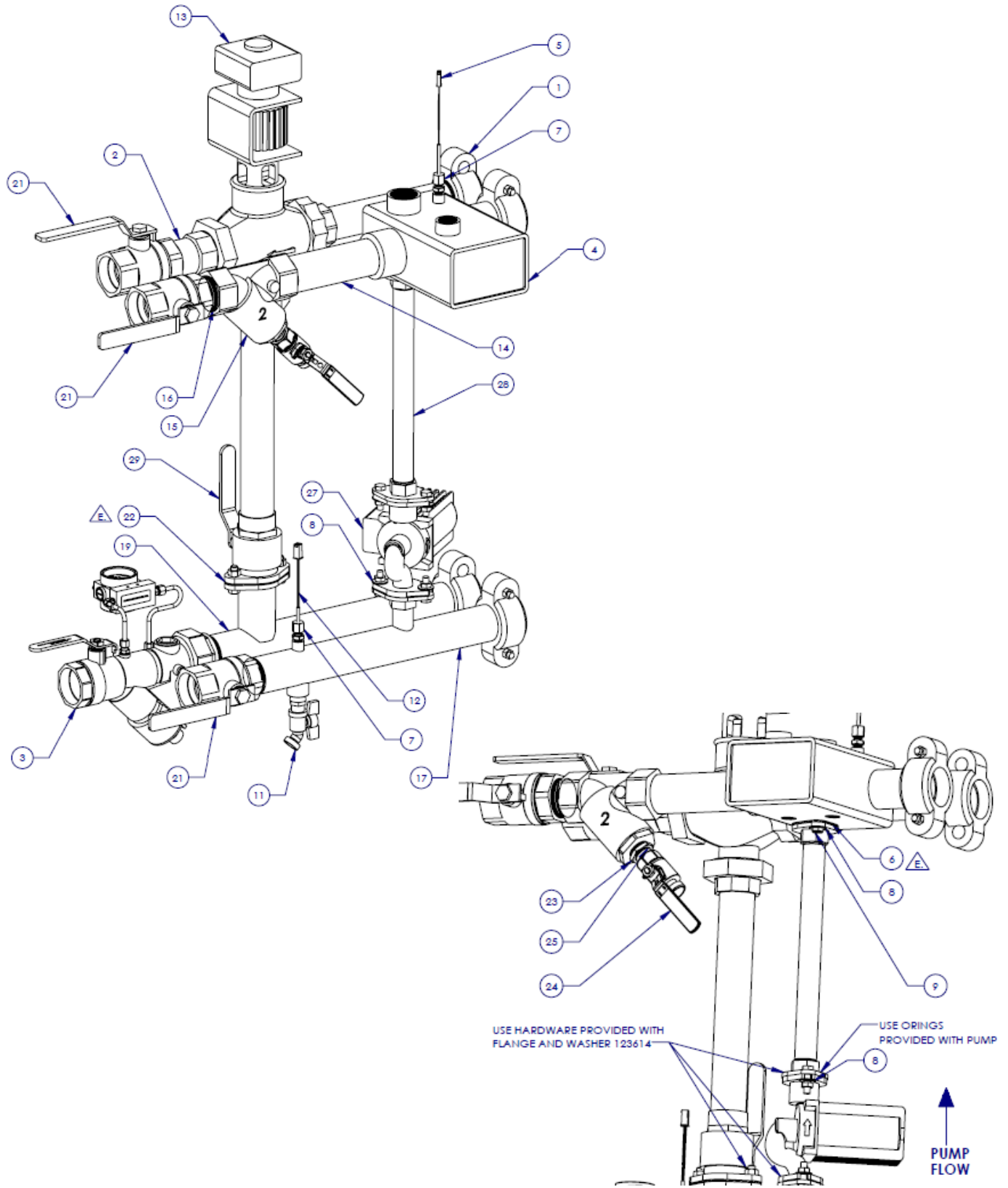

AERCO International, Inc. Blauvelt, NY 10913	SmartPlate 2.0" Piping Assembly	1/22/2020
	22264-TAB rev E	Sheet 2 of 2

CONTROL BOX ASSEMBLY – SINGLE WALL & DOUBLE WALL			
Item #	Qty	Part #	Description
1	1	65082	TRANSFORMER, X075CBA, 120/240 TO 24 VAC
2	1	64028-7	TEMPERATURE INDICATOR CONTROLLER - SP23, SPDW23
		64028-20	TEMPERATURE INDICATOR CONTROLLER: SP33, SPDW32
		64028-9	TEMPERATURE INDICATOR CONTROLLER: SP45, SPDW42
		64028-10	TEMPERATURE INDICATOR CONTROLLER: SP69, SPDW61
		64028-23	TEMPERATURE INDICATOR CONTROLLER: SP150, SPDW113
3	2	64056	BOILER WATER TEMPERATURE INDICATOR
4	1	60003	ON/OFF SWITCH
* 15	1	63009-3	EXTERNAL HARNESS (COMPLETE HARNESS)
THE FOLLOWING PART NUMBERS ARE SUB-COMPONENTS OF 63009-3:			
*	1	63009-52	HOT WATER OUT-TO-TEMP CTRL. WIRING HARNESS
*	1	63009-53	HOT WATER OUT-TO-OVER TEMP SW. WIRING HARNESS
*	1	63009-55	BOILER WATER IN WIRING HARNESS
*	1	63009-57	BOILER WATER OUT WIRING HARNESS
*	1	63009-58	MIXED INLET TEMP WIRING HARNESS
*	1	63009-61	RECIRCULATION PUMP WIRING HARNESS
*	1	63009-64	CONTROL VALVE WIRING HARNESS
THE FOLLOWING PART NUMBERS ARE SUB-COMPONENTS OF 63009-64:			
*		63009-62	ACTUATOR SIGNAL WIRING HARNESS
*		63009-63	ACTUATOR POWER WIRING HARNESS
23	1	65094-1	FUSE
24	1	65095	FUSE HOLDER
30	1	60014	OVER TEMPERATURE SWITCH
* NOT SHOWN IN DRAWING			

Model	Programmed Control Box
SP23	28047-8
SP33	28047-9
SP45	28047-10
SP69	28047-11
SP150	28047-12

Model	Programmed Control Box
SPDW23	28047-21
SPDW32	28047-21
SPDW42	28047-22
SPDW61	28047-23
SPDW113	28047-24

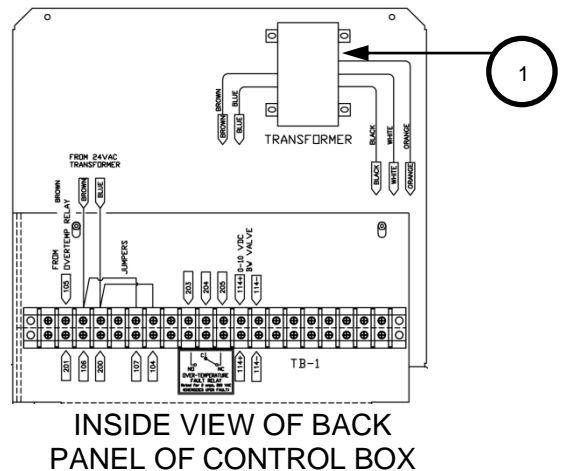
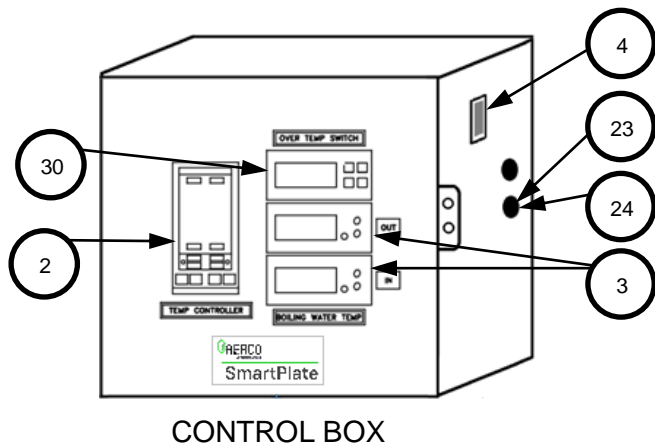

AERCO International, Inc. Blauvelt, NY 10913	SmartPlate Control Box Part List	09/24/2015
	69096 rev J	Sheet 1 of 1

APPENDIX G – RECOMMENDED SPARE PARTS

NOTE: Refer to the Parts List illustrations in Appendix E for the locations of the recommended and optional spare parts listed in the following Tables.

TABLE F-1. Recommended Emergency Spare Parts	
DESCRIPTION	PART NUMBER
Heat Exchanger (Single-Wall)	See Appendix E, Part Lists Item 2, Sheet 1,
Valve Electronic Module	65092
Temperature Controller	See Control Box, previous page
Circulator Pump (120 VAC, 60 Hz)	69259-1
Circulator Pump (220 VAC, 50 Hz)	69259-2
Circulator Pump (220 VAC, 60 Hz)	69259-3
Domestic Water Inlet Thermocouple	99042-1
Domestic Water Outlet Thermocouple	99042-2

TABLE F-2. Spare Parts Recommended for Maintenance	
DESCRIPTION	PART NUMBER
Boiler Water Differential Pressure Gauge with Compression Fittings	59188
Strainer Screen	99085
SPDW Thermal Plate with Gasket, Double-Wall Heat Exchanger	Call AERCO representative
SPDW Gasket Double-Wall Thermal Plate	81128
SPDW 4-Hole Endplate with Gasket	42204
SPDW No Hole Endplate with Gasket	42205

TABLE F-3. Spare Parts Recommended for Pump Maintenance	
DESCRIPTION	PART NUMBER
Pump Flange Gasket Set	89011-1
Pump Casing O-Ring	89011-2
Pump Capacitor (120 VAC)	89011-3
Pump Capacitor (220 VAC)	89011-4
Pump Cartridge Assembly	89011-5
Pump Fuse	69098-3

TABLE F-4. Optional Spare Parts	
DESCRIPTION	PART NUMBER
Over-Temperature Switch BW Temp Indicator	64056
Boiler Water Sensor	61018

TABLE F-5. Spare Parts Recommended for Control Valve	
DESCRIPTION	PART NUMBER
Gasket, 1-1/2"	81181
Gasket, 2"	81182



© AERCO International, Inc., 2024