

MATERIALS OF CONSTRUCTION				
PRESSURE VESSEL	SHELL-3/8" & HEAD-1/2" : C.S. SA-53 GR.B OR SA-516 GR.70 COMBUSTION CHAMBER-1/4" ST.ST'L, SA-240, 439SS EXPANSION JOINTS/PLATES-1/4" ST.ST'L, SA-240,439SS			
HEAT EXCHANGER	UPPER & LOWER TUBESHEET-1/4" ST.ST'L, SA-240,439SS TUBES-ST.ST'L, 5/8"O.D. X .049"WALL SA-249,439SS			
CONNECTIONS	PIPES-SCH 40 C.S. SA-53 E/B OR SA-106 S/B ELBOWS-SCH 40 C.S. ASTM A234 GR. WPB/ANSI B16.9 FLANGES-150# ASTM A105/ANSI B16.5			
HEAT EXCHANGERS & COMBUSTION CHAMBER DESIGN STANDARDS				
MAX. WORKING PRESS. (PSIG)	MAXIMUM TEMP. (°F)	TEST PRESS. (PSIG)	HT'G SURFACE SQ.FT.	MIN. RELIEF VA. CAPACITY MBH
160	210	240	346	4000
160	210	240	346	5000N
ASME B & PV CODE: SECTION IV STAMP H				

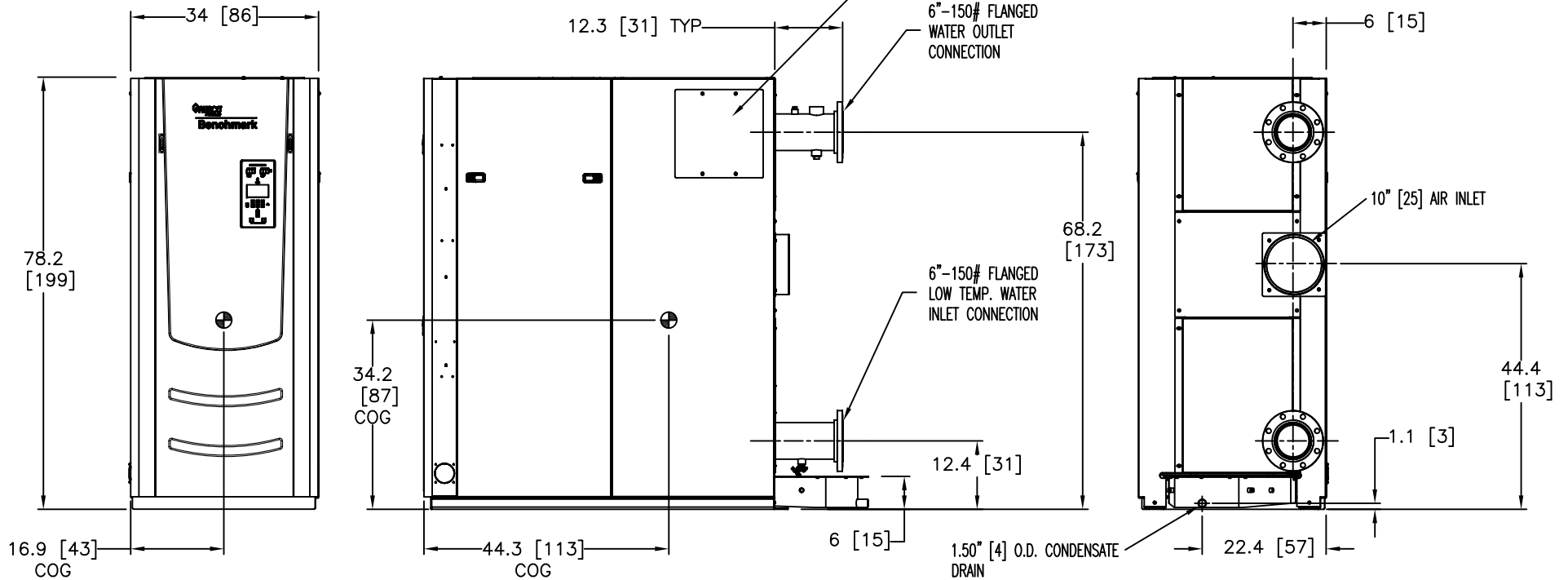

- NOTES:
- 1) ALL DIMENSIONS SHOWN ARE IN INCHES (CENTIMETERS FOR REFERENCE).
  - 2) RELIEF VALVE, TRIDICATOR & CONDENSATE TRAP ARE INCLUDED SEPARATELY IN SHIPMENT.
  - 3) AERCO RESERVES THE RIGHT TO MODIFY BOILER DIMENSIONS WITHOUT PRIOR NOTICE

**AERCO**  
A WATTS Brand

100 ORITANI DRIVE BLAUVELT, NY 10913  
aerco.com

BENCHMARK® 4000/5000N MBH NATURAL GAS  
BOILER DIMENSIONAL DRAWING

DWN. BY	K.S.	DATE	060719	AP-A-1052	REV. F
SCALE		SIZE	A		
CHKD.		APPD.			
REV. DATE	K.S.		071020		