

SIDE VIEW

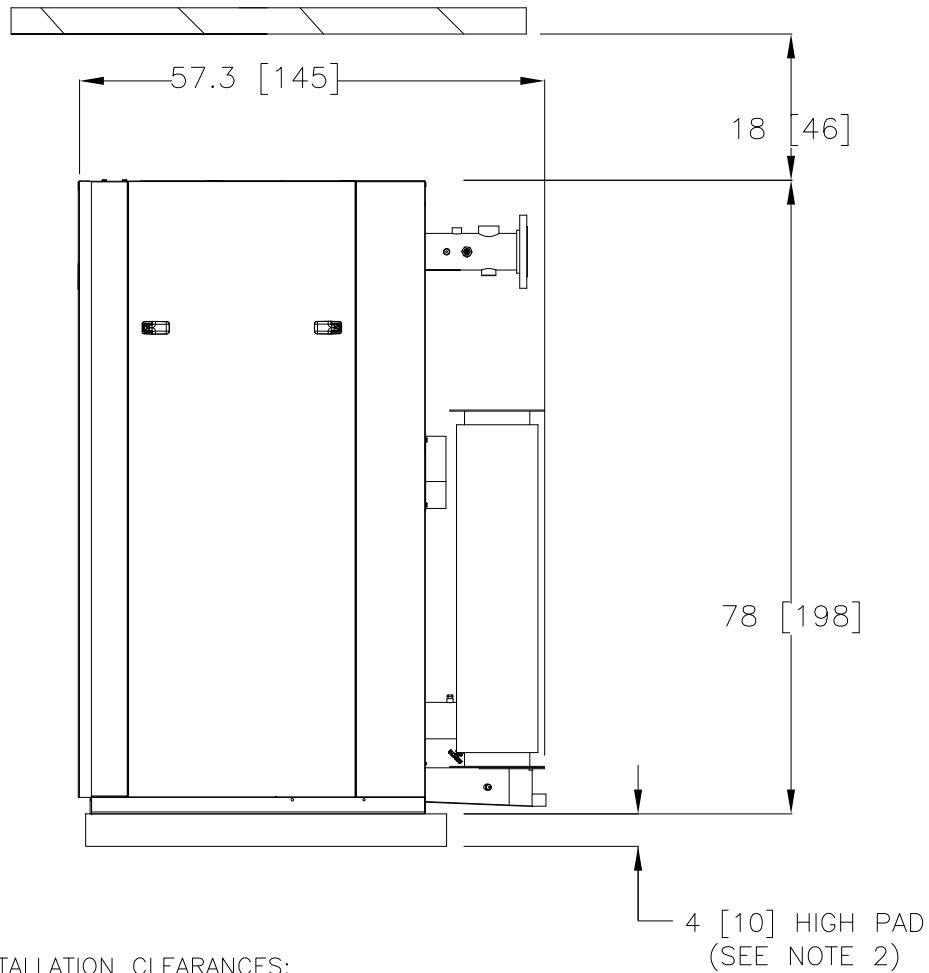

REAR

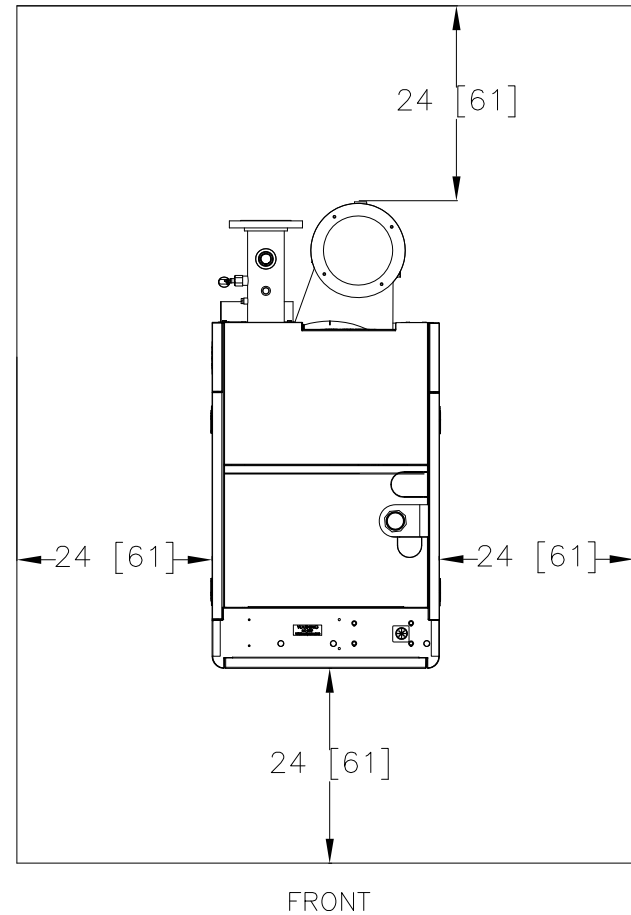

INSTALLATION CLEARANCES:

- 1) THIS APPLIANCE MAY BE INSTALLED ON COMBUSTIBLE FLOORING
- 2) MINIMUM CLEARANCES TO ADJACENT CONSTRUCTION ARE AS FOLLOWS:
 - LEFT & RIGHT SIDES: 24"
 - FRONT: 24"
 - REAR: 24"
 - CEILING HIEGHT: 100"

NOTES:

1. ALL DIMENSIONS SHOWN ARE IN INCHES (CENTIMETERS).
2. WHEN USING THE AERCO CONDENSATE NEUTRALIZER TANK, FOR PROPER CONDENSATE DRAINAGE, THE NEUTRALIZER TANK MUST BE INSTALLED IN A PIT OR THE BOILER AND THE AERCO CONDENSATE TRAP MUST BE ELEVATED 4" OR HIGHER ABOVE THE FLOOR. SEE CONDENSATE TANK INSTRUCTIONS TID-0074 FOR DETAILS.
3. CLEARANCE DIMENSIONS ARE MINIMUMS RECOMMENDED BY AERCO. LOCAL CODES AND AUTHORITIES SHOULD BE CONSULTED.

AERCO RESERVES THE RIGHT TO MODIFY BOILER DIMENSIONS WITHOUT PRIOR NOTICE

		100 ORITANI DRIVE BLAUVELT, NY 10913 aerco.com
CFR 1500 MBH BOILER CLEARANCE DRAWING		
DWN. BY <u>K.S.</u> DATE <u>052323</u>	SCALE _____	REV _____
REV. BY _____ DATE _____	SD-A-1280	A