

## Technical Data Sheet

# DW+ Indirect Fired Double-Wall Water Heater

The AERCO DW+ water heater is designed to satisfy potable water heating needs in commercial and institutional environments. The packaged system incorporates real-time, load tracking and responsive controls to maintain accurate hot water temperatures under diversified loads and can be fueled using steam.

Packaged with electronic controls, the heater maintains outstanding temperature control when operated under constant load conditions with variances held to  $\pm 4^{\circ}\text{F}$  under normal load changes of up to 25% of water heater capacity. An integrated load monitoring system and high turndown control valve deliver accurate temperature control without the need for storage tanks, blending valves or other temperature averaging components. When packaged with the electronic control system, the heater can be remotely monitored and/or fully integrated with BAS software.

The DW+ is constructed of double-wall tubing — two distinct, copper tube walls separate the potable water from the heat transfer medium via a vented air gap. This continuous air path is atmospherically vented through a clearly labeled, visible, leak detection port. Unit construction meets all double-wall heat exchanger requirements as set forth by BOCA (National Plumbing Code), IAPMO (Uniform Plumbing Code) and NAPHCC (National Standard Plumbing Code) the three national associations which reference double-wall requirements. All water wetted parts are 304 stainless steel, virgin Teflon, copper or copper alloy — the best materials available for longevity in even the most aggressive potable water supplies.

The unit's semi-instantaneous design (steam in tubes and water in shell) is compatible with low or high steam pressures. And installation is easy because of its small footprint (4 ft<sup>2</sup>) and doorway size. Tight temperature control, low maintenance, longevity and overall reliability make the AERCO DW+ the most logical choice for any commercial or institutional water heating installation.



## Features

- Accurate temperature control  $\pm 4^{\circ}\text{F}$
- Compact foot print <4ft<sup>2</sup>
- Fully modulating variable primary input
- All stainless, TFE, copper or copper alloy wetted surfaces
- UL-listed as Double-wall Heat Exchanger for potable hot water use
- ASME- B&PV Code Sec. VIII, Div. 1 Stamped
- 20-year warranty on pressure vessel and integral demand anticipator
- Supports a variety of applications
  - 5 to 52 PSIG steam supply (subject to valve pressure drop)
  - Set point range 50°F to 205°F
  - Single or multiple installation
  - Ideal for new or retrofit
  - ASME Working Pressure Certified
  - 185 PSIG for DW-24 & DW-68
  - 180 PSIG for DW-45

# Dimensions

SWDW24 with 1" thru 3" valves

CONTROL VALVE SIZE IN (CM)	DIM "A" IN./CM
1.00" (2.54) SCREWED END	25.9 / 65.8
1.25" (3.18) SCREWED END	25.6 / 65.0
1.50" (3.81) SCREWED END	25.7 / 65.3
2.00" (5.08) SCREWED END	27.2 / 69.1
2.50" (6.35) 150# ANSI FLANGED END	31.4 / 79.8
3.00" (7.62) 150# ANSI FLANGED END	32.3 / 82.0

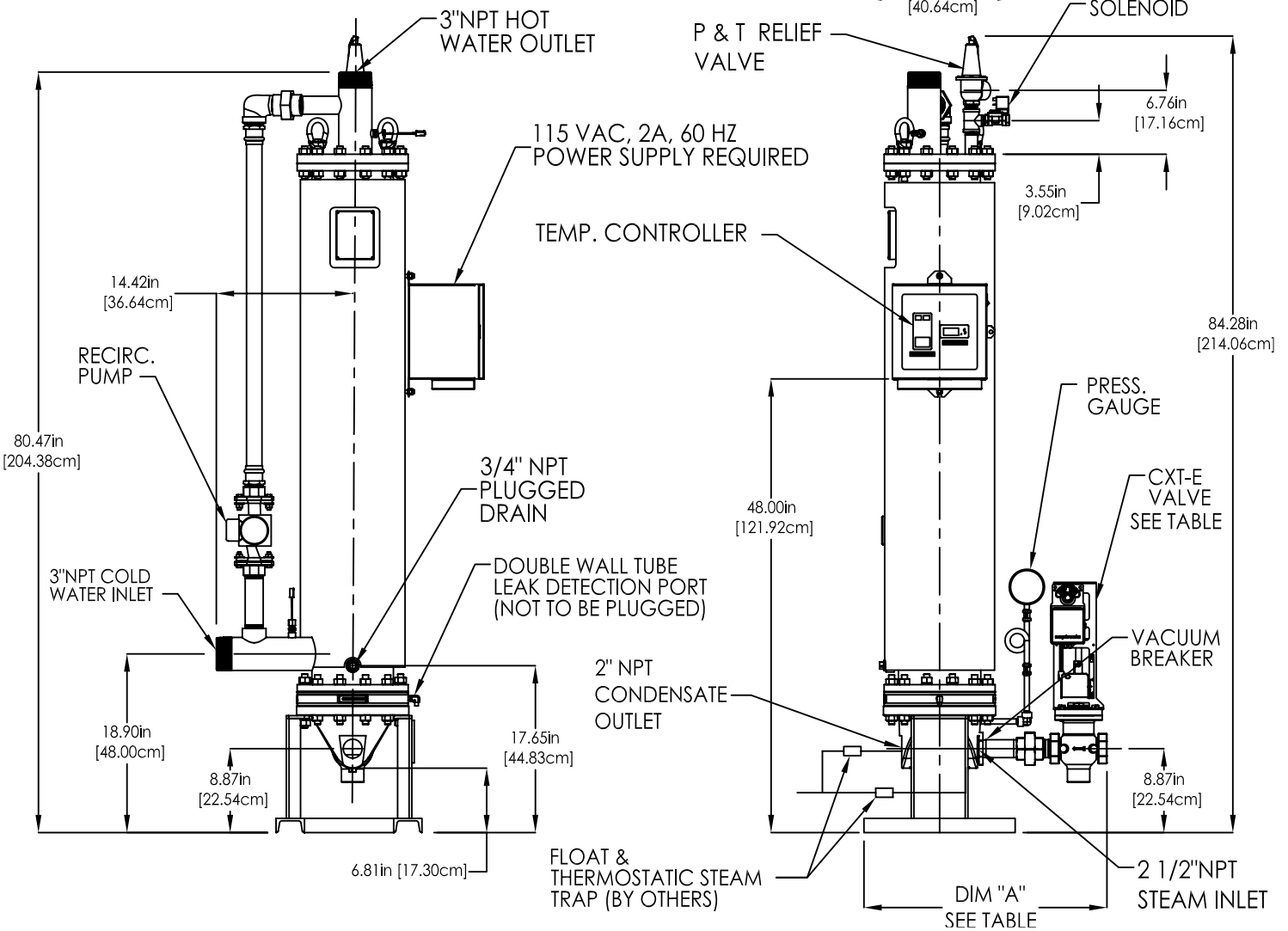

# Dimensions

## SWDW24 with 4" valve

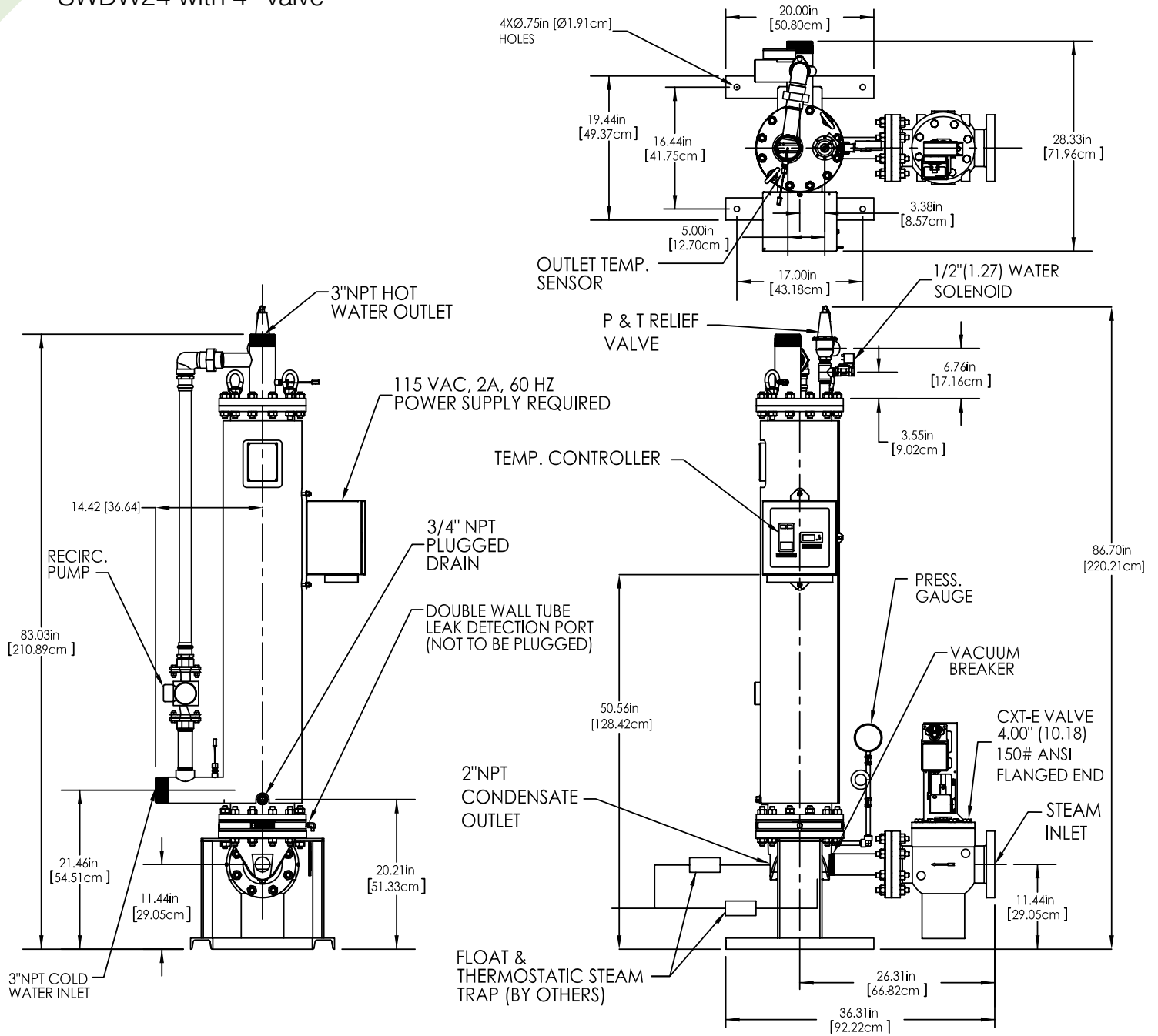

# Dimensions

SWDW45

CONTROL VALVE SIZE IN (CM)	DIM "A" IN./CM
1.00" (2.54) SCREWED END	34.3 / 87.2
1.25" (3.18) SCREWED END	34.5 / 87.7
1.50" (3.81) SCREWED END	34.2 / 87.2
2.00" (5.08) SCREWED END	35.0 / 88.9
2.50" (6.35) SCREWED END	40.1 / 101.9
3.00" (7.62) 150# ANSI FLANGED END	40.8 / 103.8
4.00" (10.18) 150# ANSI FLANGED END	35.9 / 91.2

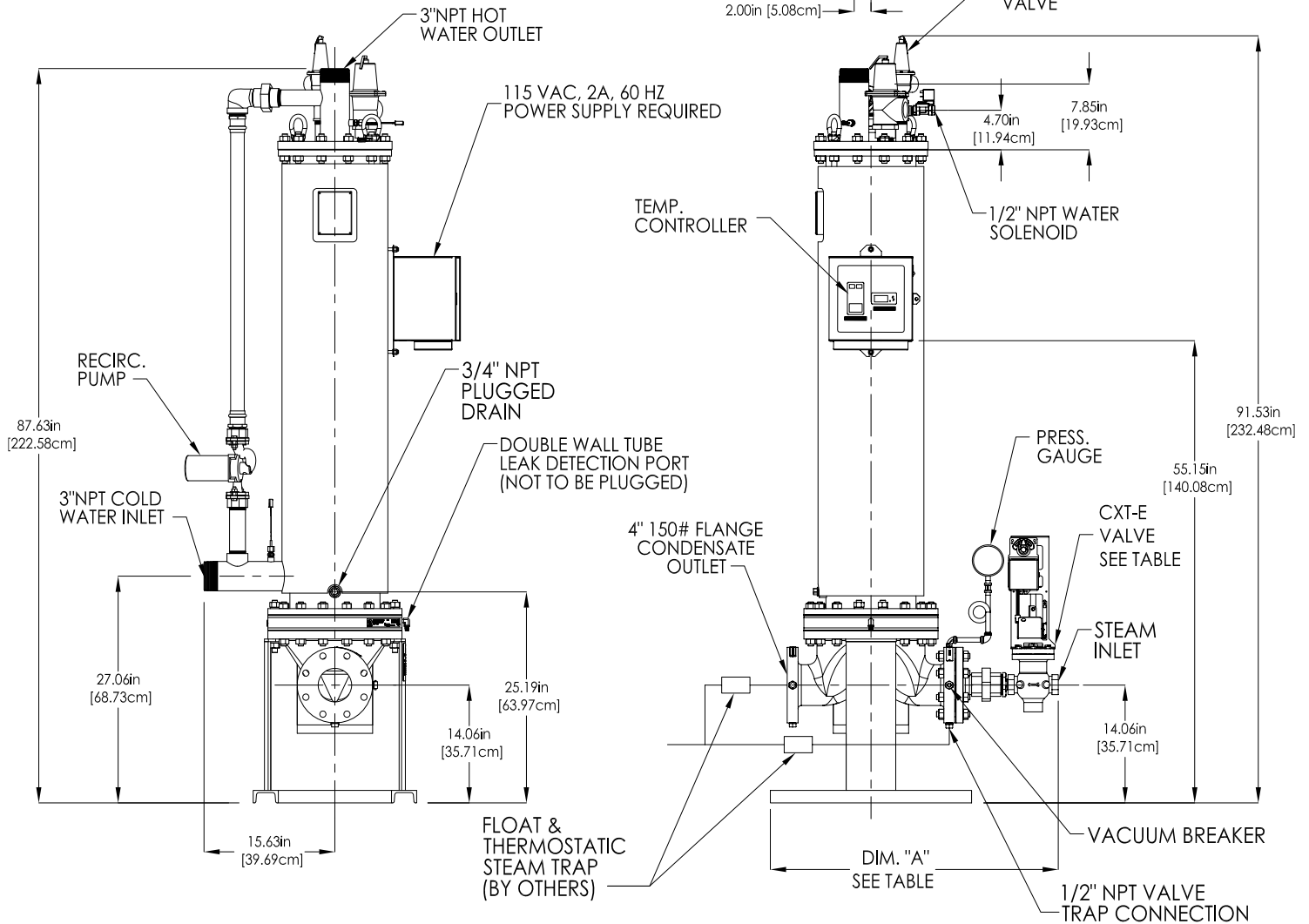
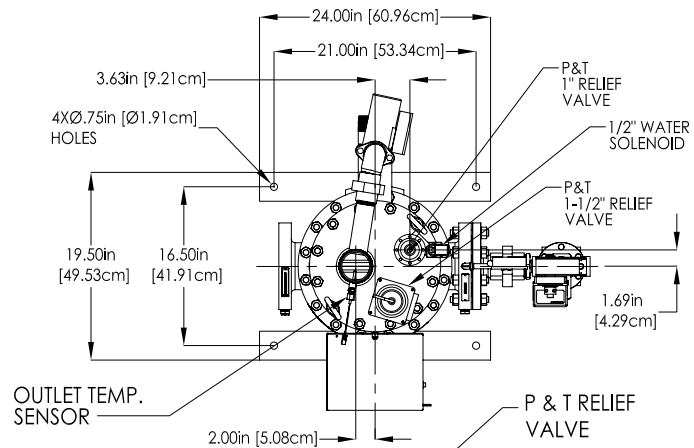

# Dimensions

SWDW68

CONTROL VALVE SIZE IN (CM)		DIM "A" IN./CM
1.00" (2.54)	SCREWED END	34.3 / 87.2
1.25" (3.18)	SCREWED END	34.5 / 87.7
1.50" (3.81)	SCREWED END	34.2 / 87.2
2.00" (5.08)	SCREWED END	35.0 / 88.9
2.50" (6.35)	SCREWED END	40.1 / 101.9
3.00" (7.62)	150# ANSI FLANGED END	40.8 / 103.8
4.00" (10.18)	150# ANSI FLANGED END	35.9 / 91.2

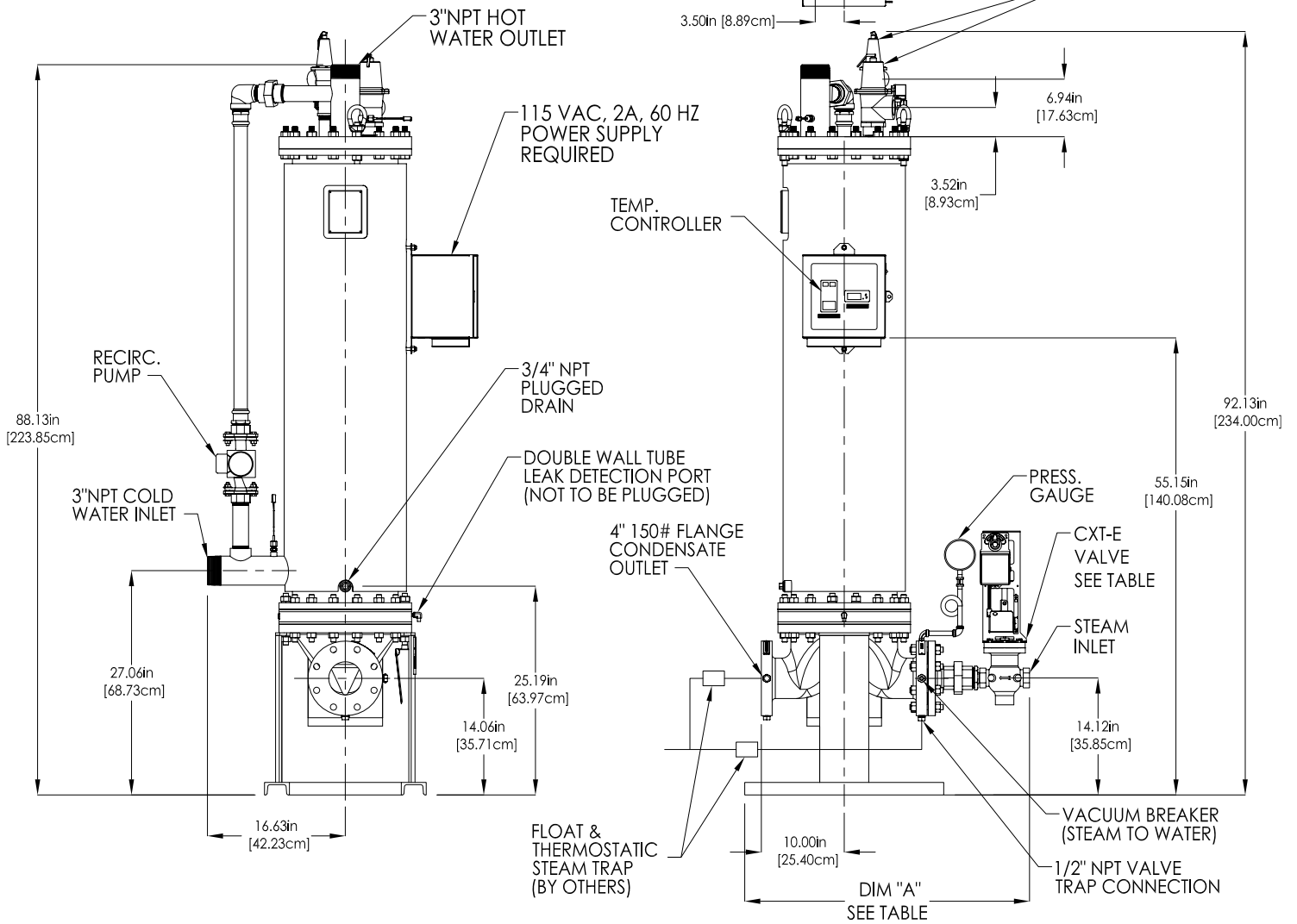
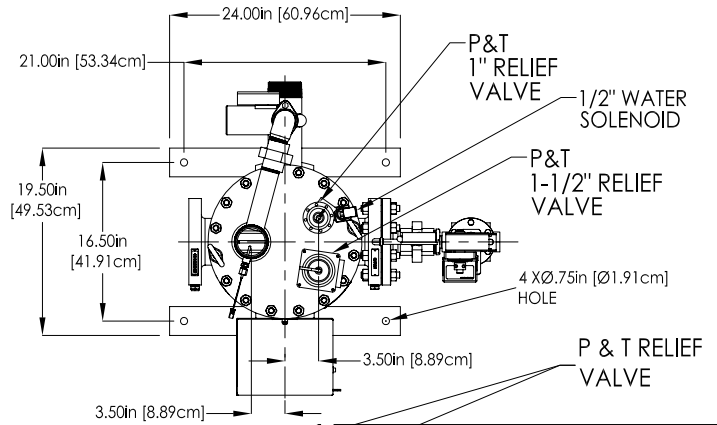

## Specifications

### w/ Electronic Controls

Shell Side Pressure Drop: 7 PSIG @ max. rated flow

Ambient Operating Temperature: 0°F to 131°F

Electrical Requirements: 120/1/60 5 Amp / 220/1/50 5 Amp

Standby Amperage Draw: 2.5 Amp

High Limit "Tripped" Amperage Draw: 3.0 Amp

### Max. Continuous Water Flow Rate

DW-24: 125 GPM

DW-45 or DW-68: 125 GPM

### Max. Intermittent Flow Rate

DW-24: 180 GPM

DW-45 or DW-68: 250 GPM

## Available Options

Dry contacts for remote "High Limit Tripped Status" indication. Pressure Relief Valves set up to 180 PSIG for high rise installations

### Weight

DW-24: 750 lb (dry); 830 lb (wet)

DW-45: 1150 lb (dry); 1270 lb (wet)

DW-68: 1350 lb (dry); 1520 lb (wet)

Max. Allowable Working Press. (tube side): 52 PSIG

Max. Shell Side Operating Press.: 180 PSIG\*

Adjustable Temperature Control: up to 205°F

Adjustable High Limit Control: up to 250°F

### Water Connection Outlet/Inlet

DW-24: 3" MNPT / 3" MNPT

DW-45 & DW-68: 3" MNPT / 3" MNPT

### Shell Volume (gal)

DW-24: 9.6

DW-45: 14.5

DW-68: 20.2

\*Standard 150 PSIG, 210°F P&T relief valve supplied; consult AERCO representative for higher settings.



Heating and Hot Water Solutions

AERCO International, Inc. • 100 Oritani Drive • Blauvelt, NY 10913  
USA: T: (845) 580-8000 • Toll Free: (800) 526-0288 • AERCO.com

© 2024 AERCO