

TECHNICAL INSTRUCTIONS

Belimo Motorized Valve Installation

Applies to:

- All **Benchmark** Boilers
- All **KC1000** Boilers

Description of Document:

This TID provides instructions for installing and wiring Belimo motorized valves as used to isolate an AERCO Benchmark or KC1000 Boiler from the system during low load conditions.



Belimo Motorized Valves

Belimo Motorized Control Valves and AERCO Part Numbers

Valve Description:	AERCO P/N:
24-240VAC/24-125VDC, Spring Return Open Valve, 3"	92084-1
24-240VAC/24-125VDC, Dual-actuator, Spring Return Open Valve, 4"	92084-2
24V, Power Open/Power Close Valve, Fail-in-Place, 3"	92084-3
24V, Power Open/Power Close Valve, Fail-in-Place, 4"	92084-4
24V, Power Open/Power Close Valve, w/Electronic Fail-Safe, 3"	92084-5
24V, Power Open/Power Close Valve, w/Electronic Fail-Safe, 4"	92084-6
24V, Power Open/Power Close Valve, w/Electronic Fail-Safe, 6"	92084-7

Revised: 08/02/2012

Technical Support:
(Mon–Fri, 8am-5pm EST)
1-800-526-0288

www.aerco.com

Disclaimer

The information contained in this manual is subject to change without notice from AERCO International, Inc. AERCO makes no warranty of any kind with respect to this material, including but not limited to implied warranties of merchantability and fitness for a particular application. AERCO International is not liable for errors appearing in this manual. Nor for incidental or consequential damages occurring in connection with the furnishing, performance, or use of this material.

Table of Contents

1. Valve Application	4
2. Valve Installation Location.....	4
3. Valve Orientation	5
4. Valve Wiring	5
5. Identifying BMK Pump Relay Option 69102.....	7
6. Sequencing of Motorized Valve Through Building Automation System.....	18
6.1 Prerequisites for Automation	18
6.2 Wiring/Programming for Automation	18
6.3 Sequence of Automation Functions	19
Belimo Motorized Control Valve Warranty.....	20

1. Valve Application

These valves are only used to isolate a boiler from the system during low load conditions. A separate service valve **MUST** be installed for each boiler. See **Figure 1** and **Figure 2**, which show typical installation diagrams – local codes and authorities should be consulted for compliance. The primary purpose of these diagrams is to illustrate the motorized valve location – see specific piping diagram provided with the AERCO boiler for the rest of the piping details.

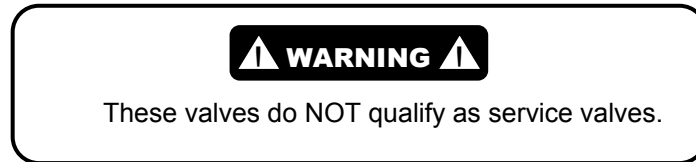

2. Valve Installation Location

- Benchmark Boilers: Do NOT install the Motorized Control Valve directly against the outlet of the boiler. The actuator will interfere with venting and boiler sheet metal.
- Provide ample clearance from venting, water piping, gas piping, electrical, controls, and other system components. The valve should be installed with a reasonable amount of “working space” around it to allow room to be able to service the valve and use the manual lever.

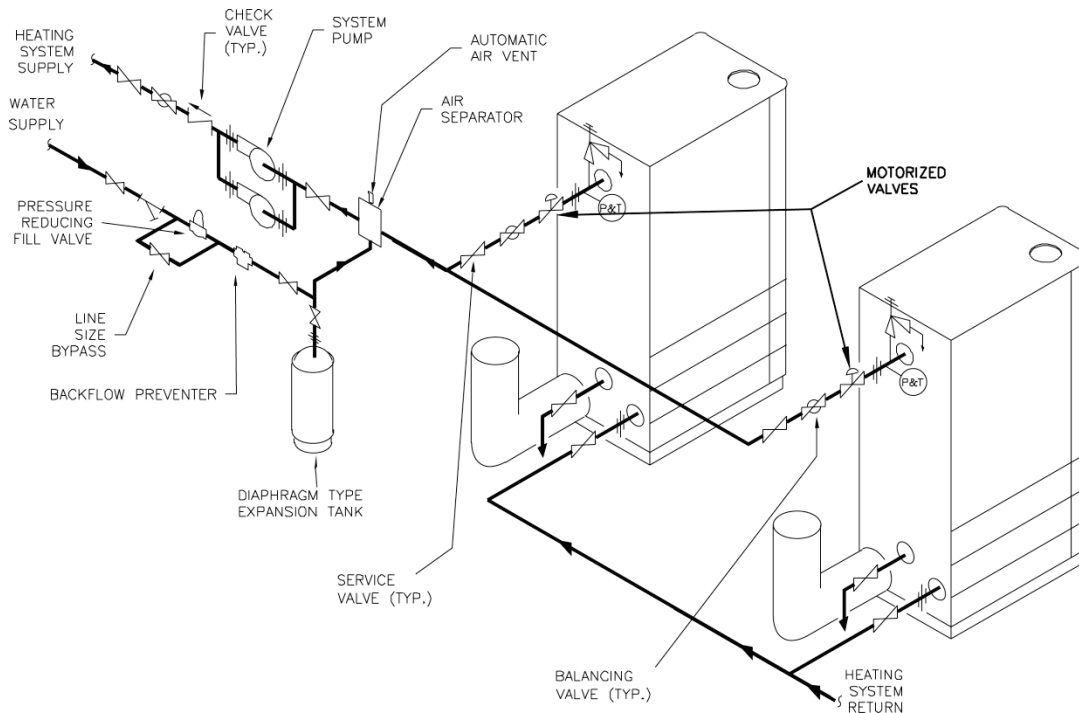

Figure 1: Multiple Boiler Piping Schematic Showing Motorized Valve Locations for AERCO Benchmark Boilers

Installing Belimo Motorized Valves on AERCO Benchmark Boilers

Technical instruction Document

TID-0028_0C

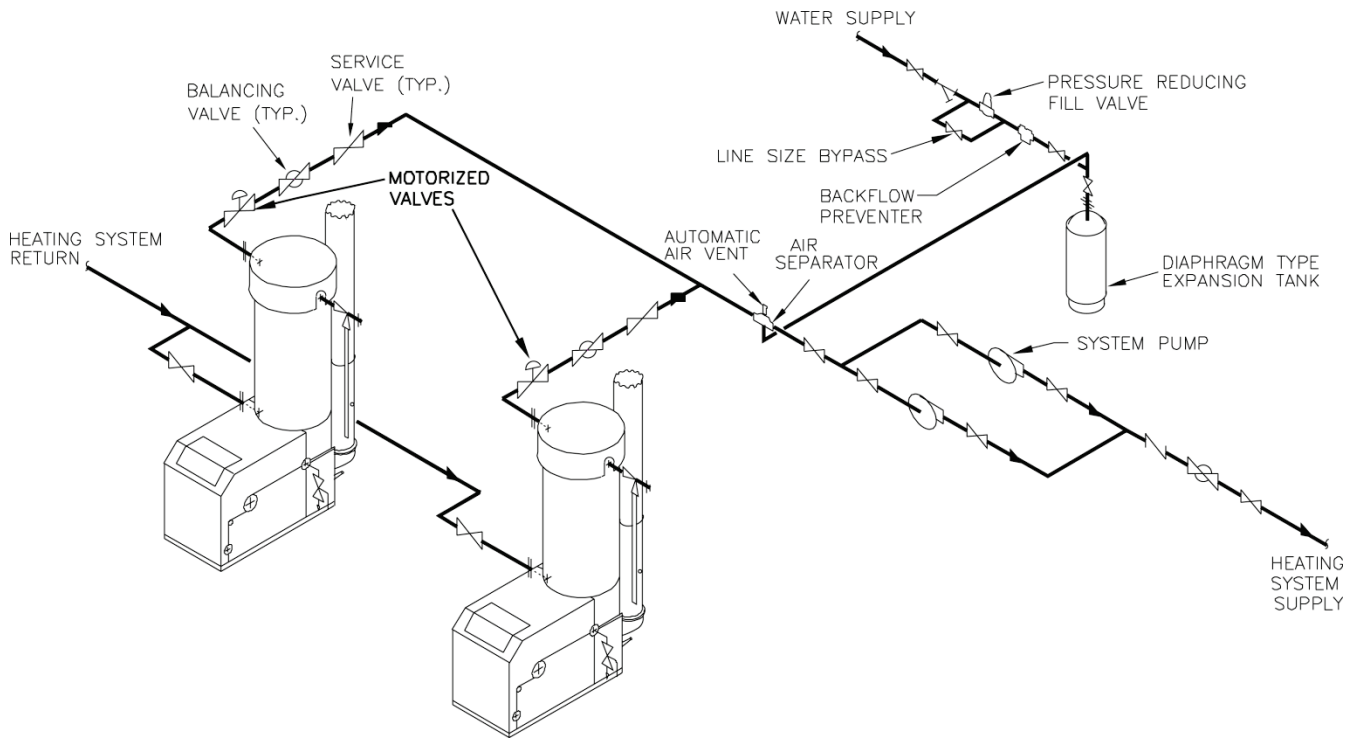

Figure 2: Multiple Boiler Piping Schematic Showing Motorized Valve Locations for AERCO KC1000 Boilers

3. Valve Orientation

The valve can be oriented in any position as long as the actuator does not go below the horizontal plane. See orientation guide from Belimo that is attached to the valve.

4. Valve Wiring

See **Table 1** on the next page to determine which of the included diagrams to use.

IMPORTANT NOTE!

The valves are supplied with 3 feet of power cable (exception: Valve PN 92084-7 is supplied with Screw Terminal for electrical connection) and 3 feet of auxiliary switch cable. If the cables are not long enough, we recommend that a distribution box be connected. The power and auxiliary cables are permanently connected to the valve and cannot be removed.

Installing Belimo Motorized Valves on AERCO Benchmark Boilers

Wiring Diagram Selection Guide for AERCO Boiler Valve Controller and AERCO supplied Belimo Valves

How to use the below chart:

1. From the first column, identify the AERCO Boiler Series to which the Belimo valve will be applied. If the Belimo valve is being installed on a BMK boiler that is already in the field, to determine if the boiler is equipped with BMK Pump Relay Option 69102, see Figure 1 on next page.
2. From the second column, identify the AERCO part number of the Belimo valve being used.
3. From the third column, identify which AERCO Boiler Valve Controller is being used in the application.
4. Use the resulting wiring diagram from the last column.

Boiler Series	Motorized Valve	AERCO Boiler Valve Controller (BVC)	Wiring Diagram to Use
Benchmark Boilers equipped with BMK Pump Relay Option 69102	Belimo 24-240VAC/24-125VDC, Spring Return Open Valves. AERCO Part Numbers 92084-1 92084-2 (Dual Actuator)	None	SD-A-904
	24V, Power open/power close Valves. Part Numbers 92084-3 92084-4 92084-5 92084-6 92084-7	None	SD-A-863
Benchmark Boilers NOT equipped with BMK Pump Relay Option 69102; KC1000 Boilers	Belimo 24-240VAC/24-125VDC, Spring Return Open Valves. AERCO Part Numbers 92084-1 92084-2 (Dual Actuator)	None	SD-A-905
		120V 4-Boiler BVC P/N 64095	SD-A-906
		120V 12-Boiler BVC P/N 64096	SD-A-907
		24V 4-Boiler BVC P/N 64097	SD-A-909
		24V 12-Boiler BVC P/N 64098	SD-A-911
	24V, Power open/power close Valves. Part Numbers 92084-3 92084-4 92084-5 92084-6 92084-7	None	SD-A-864
		24V 4-Boiler BVC P/N 64097	SD-A-908
		24V 12-Boiler BVC P/N 64098	SD-A-910

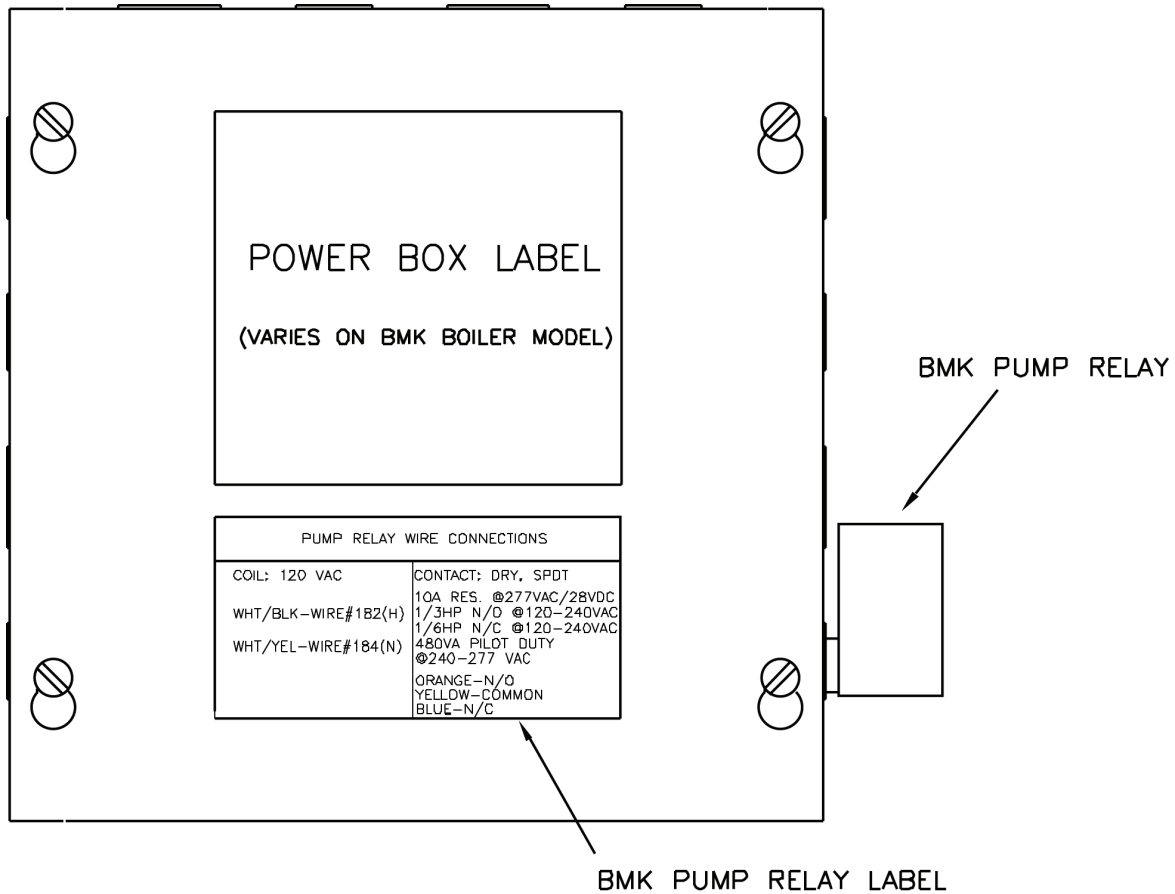

Figure 3: Identifying the Presence of BMK Pump Relay Option 69102

5. Identifying BMK Pump Relay Option 69102

If the BMK Boiler features the label and relay as called out in **Figure 3**, above, then the unit is equipped with BMK Pump Relay Option 69102.

Installing Belimo Motorized Valves on AERCO Benchmark Boilers

Technical instruction Document

TID-0028_0C

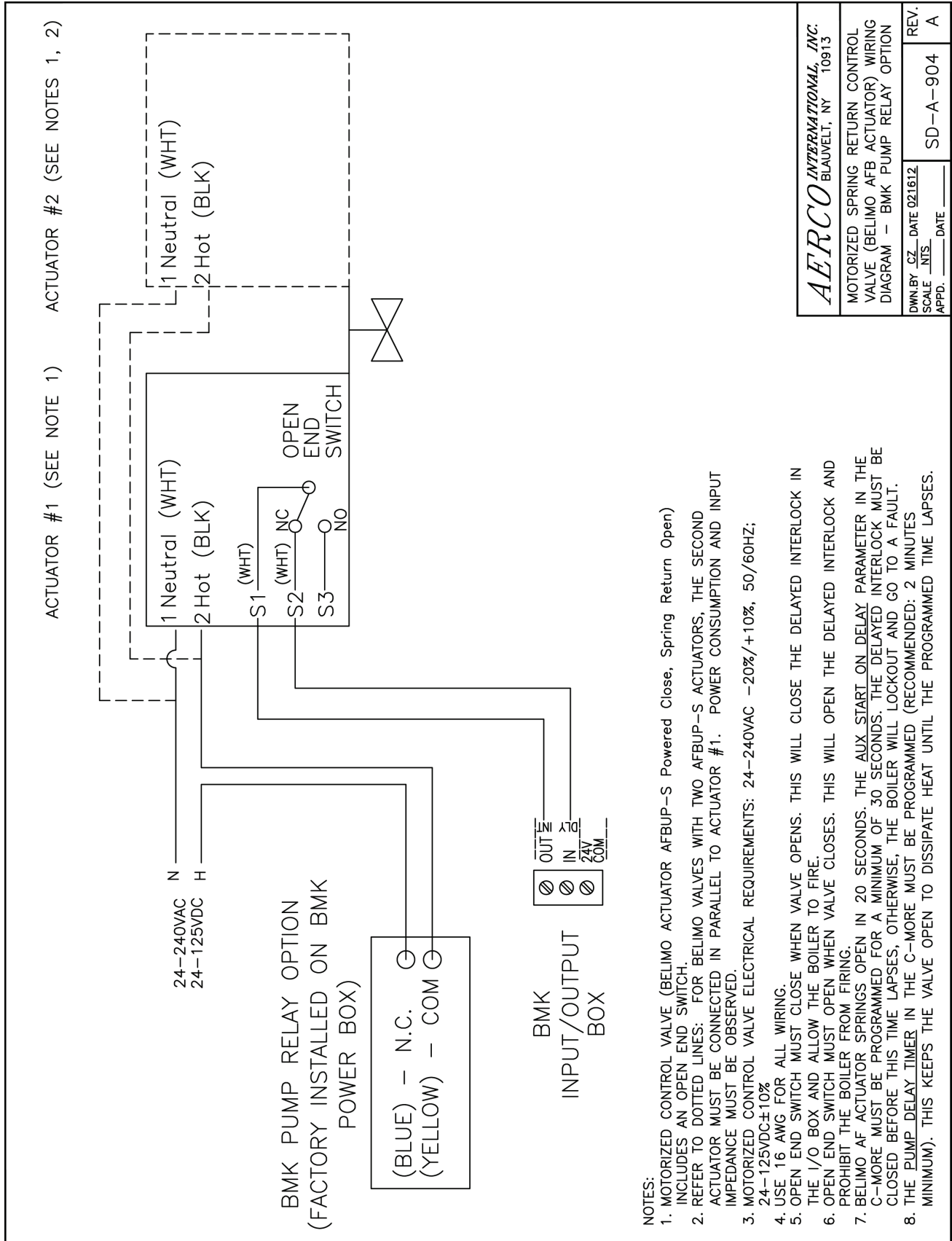

AERCO INTERNATIONAL, INC.
BLAUVELT, NY 10913

MOTORIZED SPRING RETURN CONTROL VALVE (BELIMO AFB ACTUATOR) WIRING DIAGRAM - BMK PUMP RELAY OPTION

DWG BY: CJ	DATE: 021612	REV.:
APPD: _____	DATE: _____	SD-A-904 A

Installing Belimo Motorized Valves on AERCO Benchmark Boilers

Technical Instruction Document

TID-0028_0C

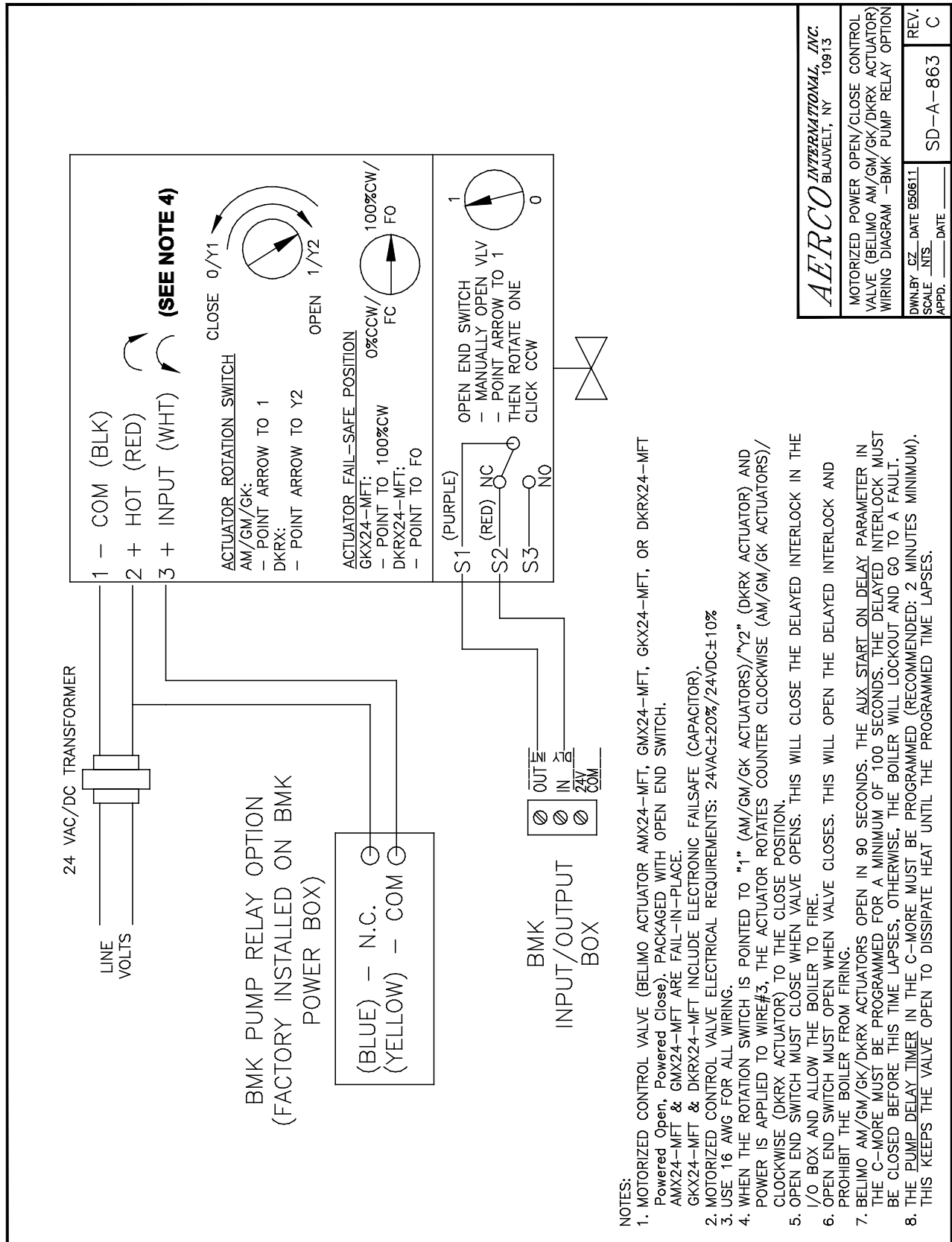

AERCO INTERNATIONAL, INC.
 BLAUVELT, NY 10913

MOTORIZED POWER OPEN/CLOSE CONTROL VALVE (BELIMO AM/GM/GK/DKRX ACTUATOR) WIRING DIAGRAM -BMK PUMP RELAY OPTION

DWN BY	CZ	DATE	050611
SCALE	N.T.S.	DATE	
REV.			C
			SD-A-863

Installing Belimo Motorized Valves on AERCO Benchmark Boilers

Technical instruction Document

TID-0028_OC

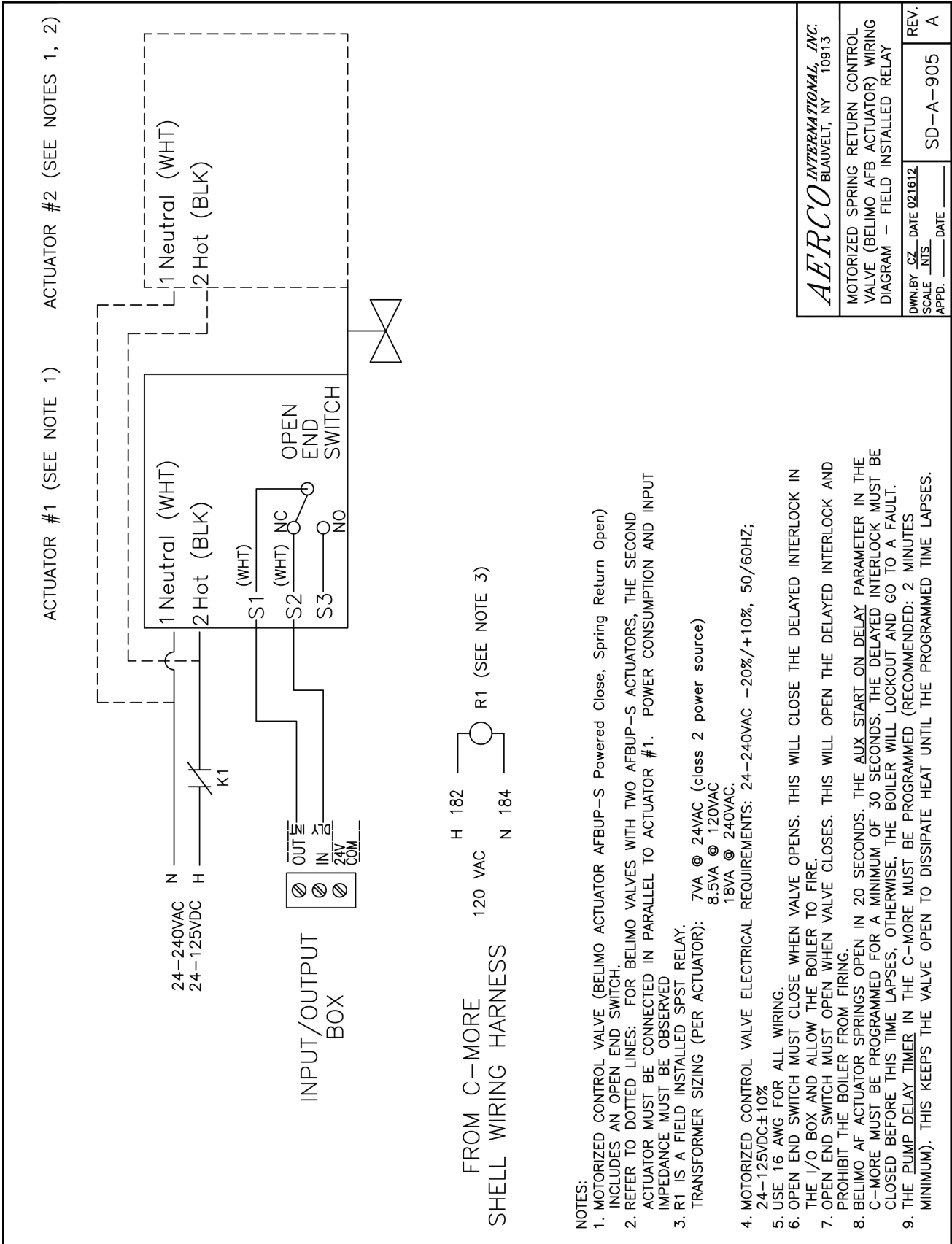

AERCO INTERNATIONAL, INC. BLAUVELT, NY 10913	
MOTORIZED SPRING RETURN CONTROL VALVE (BELIMO AFB ACTUATOR) WIRING DIAGRAM - FIELD INSTALLED RELAY	
DWN.BY: <u>CZ</u>	REV. <u>A</u>
SCALE: <u>NTS</u>	SD-A-905
APPD. _____	DATE _____

Installing Belimo Motorized Valves on AERCO Benchmark Boilers

Technical instruction Document

TID-0028_0C

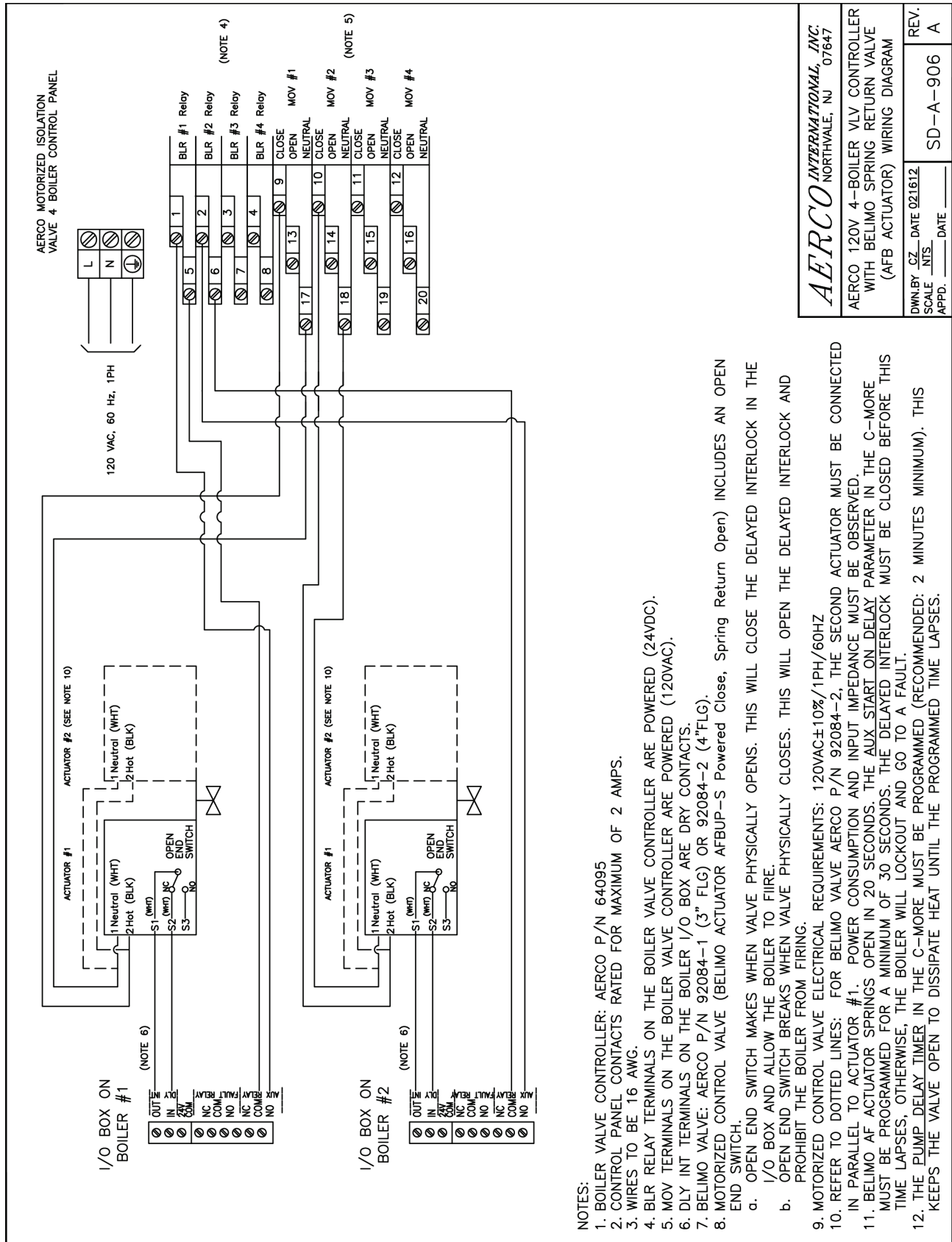

AERCO INTERNATIONAL, INC. NORTHVALE, NJ 07647	
AERCO 120V 4-BOILER VLV CONTROLLER WITH BELIMO SPRING RETURN VALVE (AFB ACTUATOR) WIRING DIAGRAM	
DWN.BY: <u> </u> DATE: <u>02/16/12</u> SCALE: <u> </u> NTS: <u> </u> APPD: <u> </u> DATE: <u> </u>	REV: <u> </u> SD-A-906 A

- NOTES:
1. BOILER VALVE CONTROLLER: AERCO P/N 64095
 2. CONTROL PANEL CONTACTS RATED FOR MAXIMUM OF 2 AMPS.
 3. WIRES TO BE 16 AWG.
 4. BLR RELAY TERMINALS ON THE BOILER VALVE CONTROLLER ARE POWERED (24VDC).
 5. MOV TERMINALS ON THE BOILER VALVE CONTROLLER ARE POWERED (120VAC).
 6. DLY INT TERMINALS ON THE BOILER I/O BOX ARE DRY CONTACTS.
 7. BELIMO VALVE: AERCO P/N 92084-1 (3" FLG) OR 92084-2 (4" FLG).
 8. MOTORIZED CONTROL VALVE (BELIMO ACTUATOR AFBUP-S Powered Close, Spring Return Open) INCLUDES AN OPEN END SWITCH.
 - a. OPEN END SWITCH MAKES WHEN VALVE PHYSICALLY OPENS. THIS WILL CLOSE THE DELAYED INTERLOCK IN THE I/O BOX AND ALLOW THE BOILER TO FIRE.
 - b. OPEN END SWITCH BREAKS WHEN VALVE PHYSICALLY CLOSSES. THIS WILL OPEN THE DELAYED INTERLOCK AND PROHIBIT THE BOILER FROM FIRING.
 9. MOTORIZED CONTROL VALVE ELECTRICAL REQUIREMENTS: 120VAC±10%/1PH/60HZ
 10. REFER TO DOTTED LINES: FOR BELIMO VALVE AERCO P/N 92084-2, THE SECOND ACTUATOR MUST BE CONNECTED IN PARALLEL TO ACTUATOR #1. POWER CONSUMPTION AND INPUT IMPEDANCE MUST BE OBSERVED.
 11. BELIMO AF ACTUATOR SPRINGS OPEN IN 20 SECONDS. THE AUX START ON DELAY PARAMETER IN THE C-MORE MUST BE PROGRAMMED FOR A MINIMUM OF 30 SECONDS. THE DELAYED INTERLOCK MUST BE CLOSED BEFORE THIS TIME LAPSES, OTHERWISE, THE BOILER WILL LOCKOUT AND GO TO A FAULT.
 12. THE PUMP DELAY TIMER IN THE C-MORE MUST BE PROGRAMMED (RECOMMENDED: 2 MINUTES MINIMUM). THIS KEEPS THE VALVE OPEN TO DISSIPATE HEAT UNTIL THE PROGRAMMED TIME LAPSES.

Installing Belimo Motorized Valves on AERCO Benchmark Boilers

Technical Instruction Document

TID-0028_0C

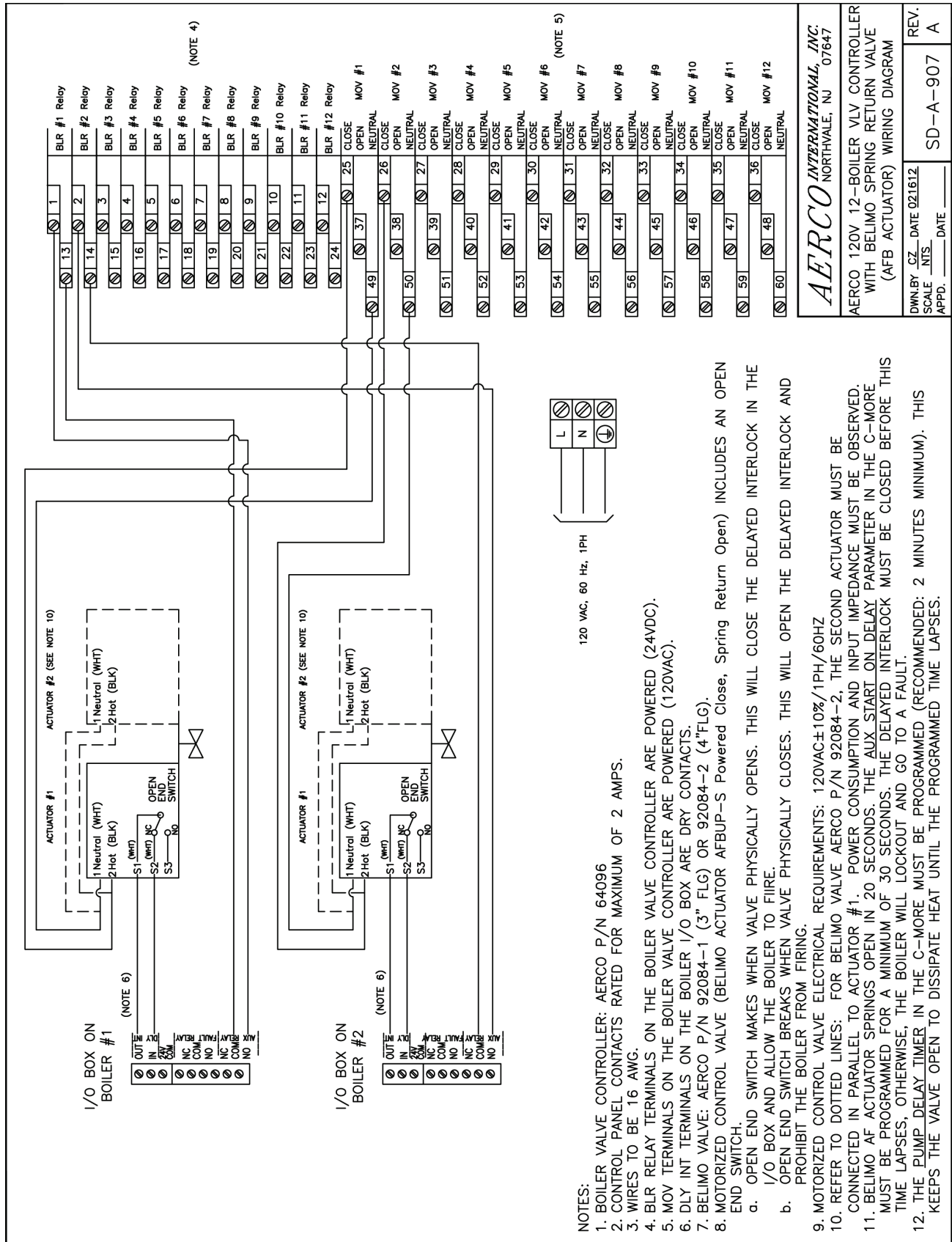

AERCO
INTERNATIONAL, INC.
NORTHVALE, NJ 07847

AERCO 120V 12-BOILER VLV CONTROLLER
WITH BELIMO SPRING RETURN VALVE
(AFB ACTUATOR) WIRING DIAGRAM

DWN.BY	CZ	DATE	021612
SCALE	NTS	DATE	
APPD.		DATE	

REV. SD-A-907 A

- NOTES:**
1. BOILER VALVE CONTROLLER: AERCO P/N 64096.
 2. CONTROL PANEL CONTACTS RATED FOR MAXIMUM OF 2 AMPS.
 3. WIRES TO BE 16 AWG.
 4. BLR RELAY TERMINALS ON THE BOILER VALVE CONTROLLER ARE POWERED (24VDC).
 5. MOV TERMINALS ON THE BOILER VALVE CONTROLLER ARE POWERED (120VAC).
 6. DLY INT TERMINALS ON THE BOILER I/O BOX ARE DRY CONTACTS.
 7. BELIMO VALVE: AERCO P/N 92084-1 (3" FLG) OR 92084-2 (4" FLG).
 8. MOTORIZED CONTROL VALVE (BELIMO ACTUATOR AFBUP-S Powered Close, Spring Return Open) INCLUDES AN OPEN END SWITCH.
 - a. OPEN END SWITCH MAKES WHEN VALVE PHYSICALLY OPENS. THIS WILL CLOSE THE DELAYED INTERLOCK IN THE I/O BOX AND ALLOW THE BOILER TO FIRE.
 - b. OPEN END SWITCH BREAKS WHEN VALVE PHYSICALLY CLOSSES. THIS WILL OPEN THE DELAYED INTERLOCK AND PROHIBIT THE BOILER FROM FIRING.
 9. MOTORIZED CONTROL VALVE ELECTRICAL REQUIREMENTS: 120VAC±10%/1PH/60HZ
 10. REFER TO DOTTED LINES: FOR BELIMO VALVE AERCO P/N 92084-2, THE SECOND ACTUATOR MUST BE CONNECTED IN PARALLEL TO ACTUATOR #1. POWER CONSUMPTION AND INPUT IMPEDANCE MUST BE OBSERVED.
 11. BELIMO AF ACTUATOR SPRINGS OPEN IN 20 SECONDS. THE AUX START ON DELAY PARAMETER IN THE C-MORE MUST BE PROGRAMMED FOR A MINIMUM OF 30 SECONDS. THE DELAYED INTERLOCK MUST BE CLOSED BEFORE THIS TIME LAPSES; OTHERWISE, THE BOILER WILL LOCKOUT AND GO TO A FAULT.
 12. THE PUMP DELAY TIMER IN THE C-MORE MUST BE PROGRAMMED (RECOMMENDED: 2 MINUTES MINIMUM). THIS KEEPS THE VALVE OPEN TO DISSIPATE HEAT UNTIL THE PROGRAMMED TIME LAPSES.

Installing Belimo Motorized Valves on AERCO Benchmark Boilers

Technical Instruction Document

TID-0028_0C

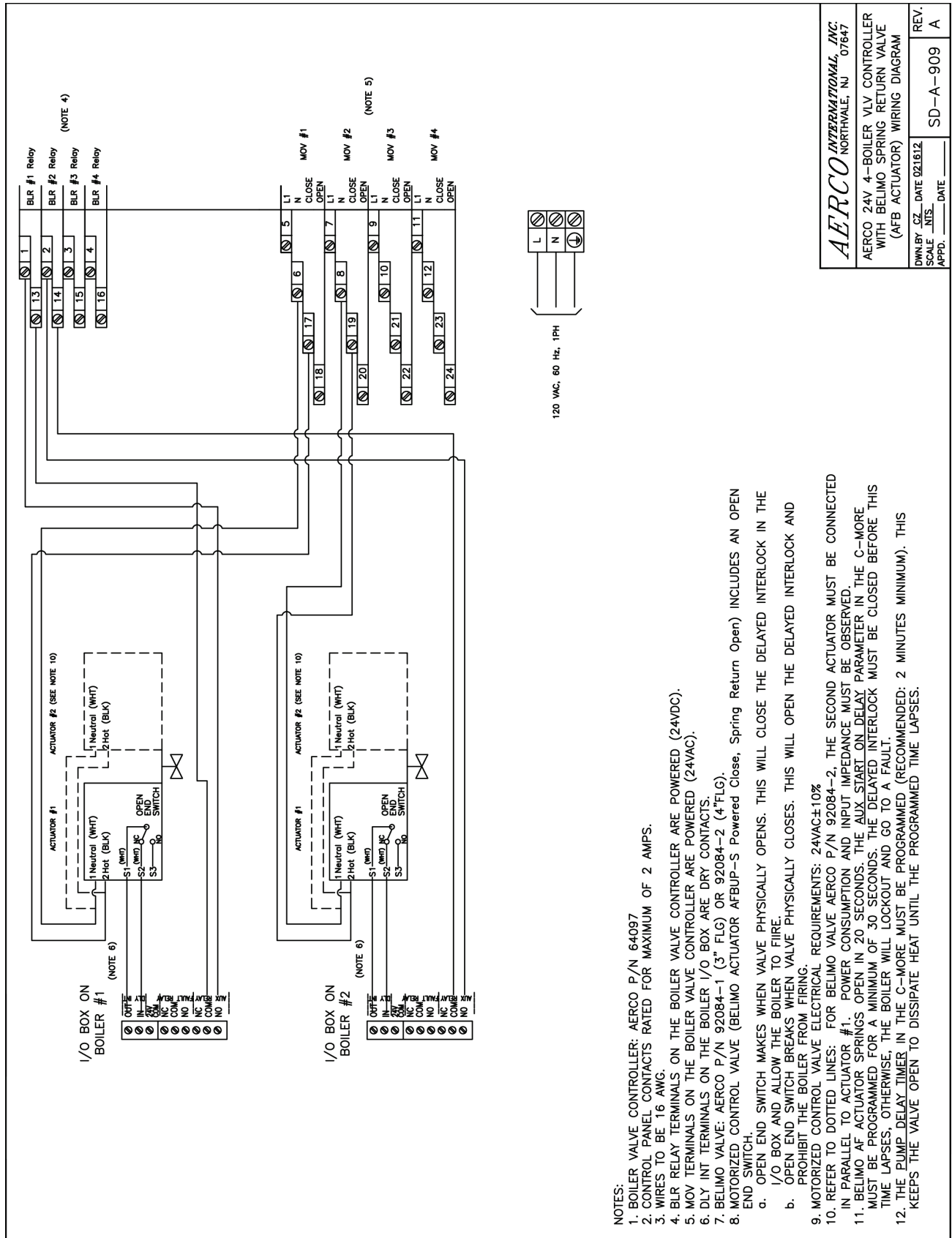

AERCO INTERNATIONAL, INC. NORTHVALE, NJ 07647	
AERCO 24V 4-BOILER VLV CONTROLLER WITH BELIMO SPRING RETURN VALVE (AFB ACTUATOR) WIRING DIAGRAM	
DOWN BY SCALE APPD.	DATE
REV. SD-A-909	A

- NOTES:**
1. BOILER VALVE CONTROLLER: AERCO P/N 64097
 2. CONTROL PANEL CONTACTS RATED FOR MAXIMUM OF 2 AMPS.
 3. WIRES TO BE 16 AWG.
 4. BLR RELAY TERMINALS ON THE BOILER VALVE CONTROLLER ARE POWERED (24VDC).
 5. MOV TERMINALS ON THE BOILER VALVE CONTROLLER ARE POWERED (24VAC).
 6. DLY INT TERMINALS ON THE BOILER I/O BOX ARE DRY CONTACTS.
 7. BELIMO VALVE: AERCO P/N 92084-1 (3" FLG) OR 92084-2 (4" FLG).
 8. MOTORIZED CONTROL VALVE (BELIMO ACTUATOR AFBUP-S Powered Close, Spring Return Open) INCLUDES AN OPEN END SWITCH.
 - a. OPEN END SWITCH MAKES WHEN VALVE PHYSICALLY OPENS. THIS WILL CLOSE THE DELAYED INTERLOCK IN THE I/O BOX AND ALLOW THE BOILER TO FIRE.
 - b. OPEN END SWITCH BREAKS WHEN VALVE PHYSICALLY CLOSES. THIS WILL OPEN THE DELAYED INTERLOCK AND PROHIBIT THE BOILER FROM FIRING.
 9. MOTORIZED CONTROL VALVE ELECTRICAL REQUIREMENTS: 24VAC±10%
 10. REFER TO DOTTED LINES: FOR BELIMO VALVE AERCO P/N 92084-2, THE SECOND ACTUATOR MUST BE CONNECTED IN PARALLEL TO ACTUATOR #1. POWER CONSUMPTION AND INPUT IMPEDANCE MUST BE OBSERVED.
 11. BELIMO AF ACTUATOR SPRINGS OPEN IN 20 SECONDS. THE AUX START ON DELAY PARAMETER IN THE C-MORE TIME LAPSES, OTHERWISE, THE BOILER WILL LOCKOUT AND GO TO A FAULT.
 12. THE PUMP DELAY TIMER IN THE C-MORE MUST BE PROGRAMMED (RECOMMENDED: 2 MINUTES MINIMUM). THIS KEEPS THE VALVE OPEN TO DISSIPATE HEAT UNTIL THE PROGRAMMED TIME LAPSES.

Installing Belimo Motorized Valves on AERCO Benchmark Boilers

Technical Instruction Document

TID-0028_0C

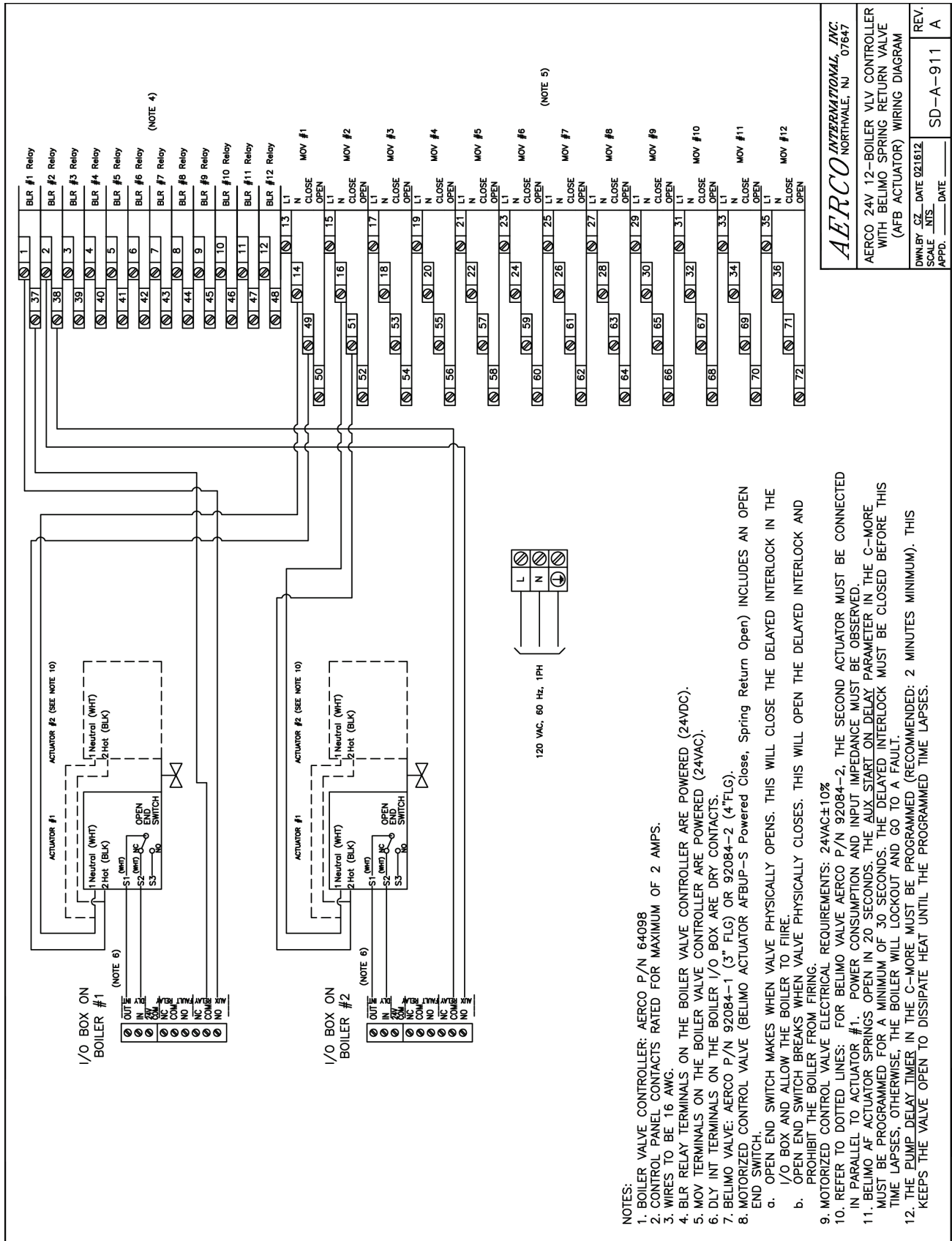

AERCO INTERNATIONAL, INC.
NORTHVALE, NJ 07647

AERCO 24V 12-BOILER VLV CONTROLLER WITH BELIMO SPRING RETURN VALVE (AFB ACTUATOR) WIRING DIAGRAM

DWN.BY: SCALE: INTS. DATE: APPD:

REV. SD-A-911 A

- NOTES:**
1. BOILER VALVE CONTROLLER: AERCO P/N 64098
 2. CONTROL PANEL CONTACTS RATED FOR MAXIMUM OF 2 AMPS.
 3. WIRES TO BE 16 AWG.
 4. BLR RELAY TERMINALS ON THE BOILER VALVE CONTROLLER ARE POWERED (24VDC).
 5. MOV TERMINALS ON THE BOILER VALVE CONTROLLER ARE POWERED (24VAC).
 6. DLY INT TERMINALS ON THE BOILER I/O BOX ARE DRY CONTACTS.
 7. BELIMO VALVE: AERCO P/N 92084-1 (3" FLG) OR 92084-2 (4" FLG).
 8. MOTORIZED CONTROL VALVE (BELIMO ACTUATOR AFBUP-S Powered Close, Spring Return Open) INCLUDES AN OPEN END SWITCH.
 - a. OPEN END SWITCH MAKES WHEN VALVE PHYSICALLY OPENS. THIS WILL CLOSE THE DELAYED INTERLOCK IN THE I/O BOX AND ALLOW THE BOILER TO FIRE.
 - b. OPEN END SWITCH BREAKS WHEN VALVE PHYSICALLY CLOSES. THIS WILL OPEN THE DELAYED INTERLOCK AND PROHIBIT THE BOILER FROM FIRING.
 9. MOTORIZED CONTROL VALVE ELECTRICAL REQUIREMENTS: 24VAC±10%
 10. REFER TO DOTTED LINES: FOR BELIMO VALVE AERCO P/N 92084-2, THE SECOND ACTUATOR MUST BE CONNECTED IN PARALLEL TO ACTUATOR #1. POWER CONSUMPTION AND INPUT IMPEDANCE MUST BE OBSERVED.
 11. BELIMO AF ACTUATOR SPRINGS OPEN IN 20 SECONDS. THE AUX START ON DELAY PARAMETER IN THE C-MORE MUST BE PROGRAMMED FOR A MINIMUM OF 30 SECONDS. THE DELAYED INTERLOCK MUST BE CLOSED BEFORE THIS TIME LAPSES; OTHERWISE, THE BOILER WILL LOCKOUT AND GO TO A FAULT.
 12. THE PUMP DELAY TIMER IN THE C-MORE MUST BE PROGRAMMED (RECOMMENDED: 2 MINUTES MINIMUM). THIS KEEPS THE VALVE OPEN TO DISSIPATE HEAT UNTIL THE PROGRAMMED TIME LAPSES.

Installing Belimo Motorized Valves on AERCO Benchmark Boilers

Technical Instruction Document

TID-0028_0C

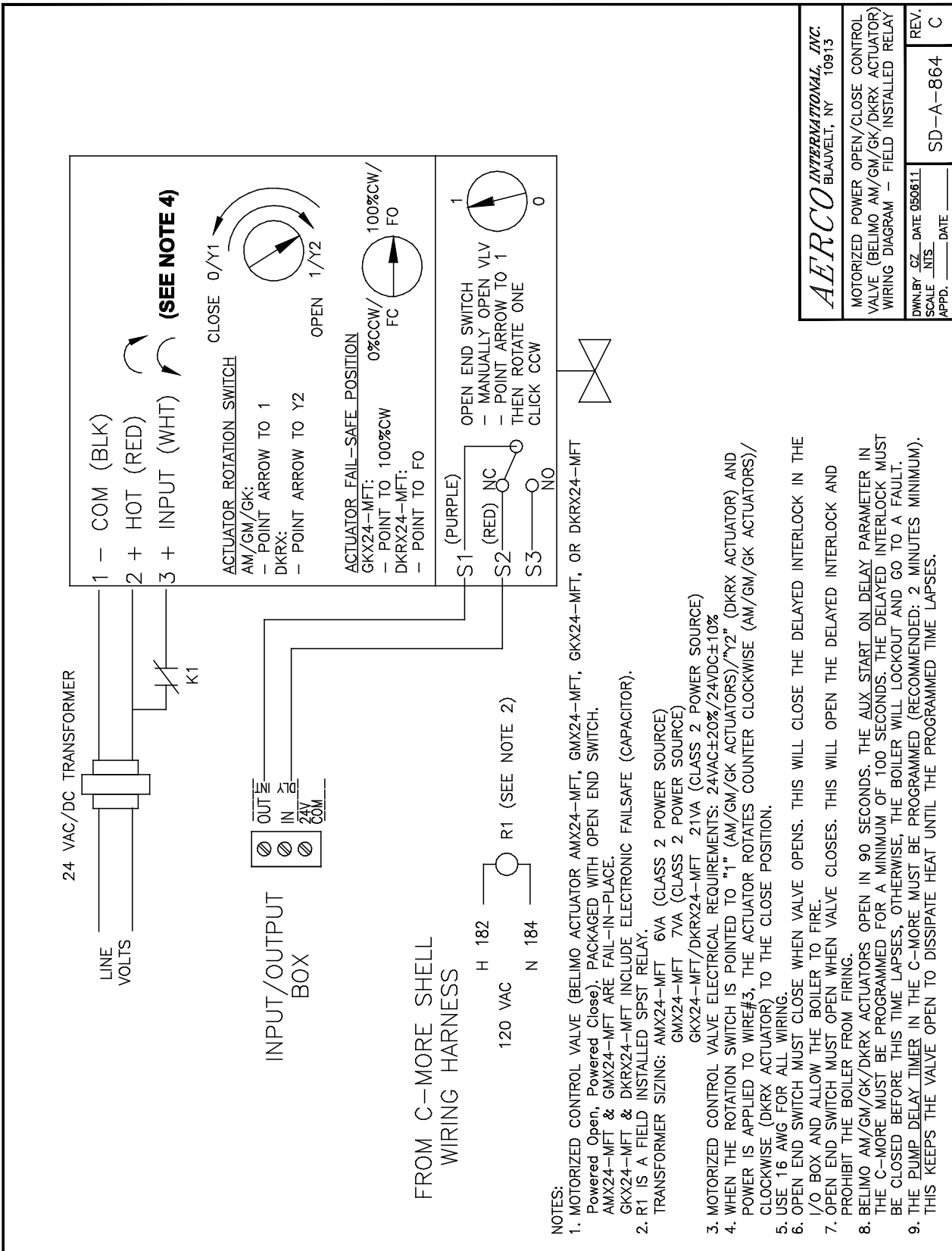

AERCO INTERNATIONAL, INC.
BLAUVELT, NY 10913

MOTORIZED POWER OPEN/CLOSE CONTROL VALVE (BELIMO AM/GM/GK/DKRX ACTUATOR) WIRING DIAGRAM - FIELD INSTALLED RELAY

DWN BY	CZ	DATE	050611	REV.	C
SCALE	NTS	DATE		APPD.	SD-A-864

Installing Belimo Motorized Valves on AERCO Benchmark Boilers

Technical Instruction Document

TID-0028_0C

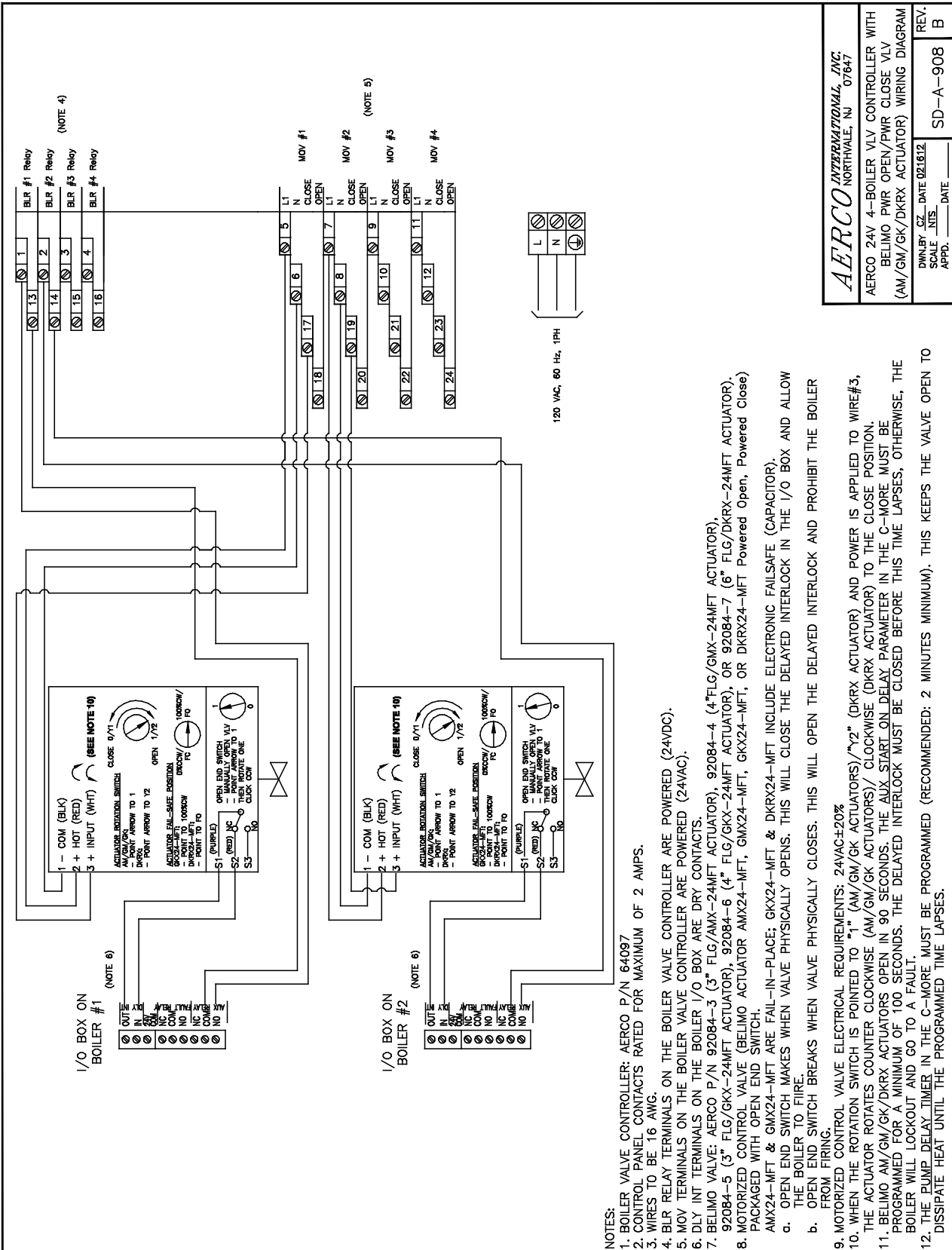

AERCO INTERNATIONAL, INC. NORTHVALE, NJ 07867	
AERCO 24V 4-BOILER VLV CONTROLLER WITH BELIMO PWR OPEN/PWR CLOSE VLV (AM/GM/GK/DKRX ACTUATOR) WIRING DIAGRAM	
DWY BY: <u> </u> DATE: <u>02/12/12</u>	REV. <u> </u>
APPD: <u> </u> DATE: <u> </u>	SD-A-908 B

Installing Belimo Motorized Valves on AERCO Benchmark Boilers

Technical Instruction Document

TID-0028_0C

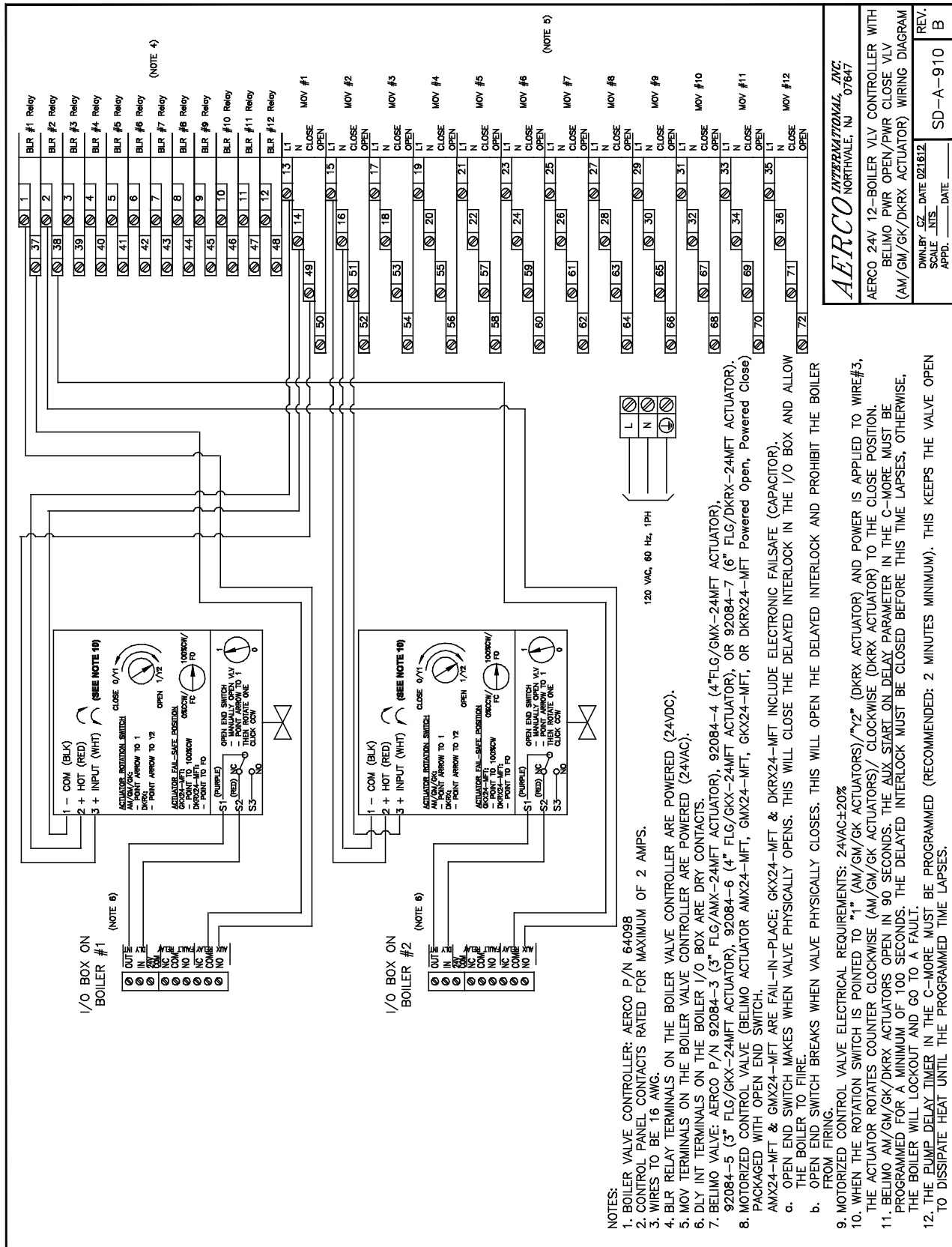

AERCO INTERNATIONAL, INC.
 NORTHVALE, NJ 07647

AERCO 24V 12-BOILER VLV CONTROLLER WITH BELIMO PWR OPEN/PWR CLOSE VLV (AM/GM/GK/DKRX ACTUATOR) WIRING DIAGRAM

DWN BY: SCALE: DATE: REV. B

APPL: SD-A-910

6. Sequencing of Motorized Valve Through Building Automation System

6.1 Prerequisites for Automation

1. Motor Operated Valve (MOV) for each boiler must have a proof of open switch.
2. Check with valve manufacturer for the time it requires for the valve to fully open. Opening time must not exceed 110 seconds.

6.2 Wiring/Programming for Automation

1. Use the Aux Relay of the C-More control system to signal the Building Automation System (BAS) that a boiler is in demand.
2. Wire the proof of open switch of the MOV to the Delayed Interlock of the C-More control system.

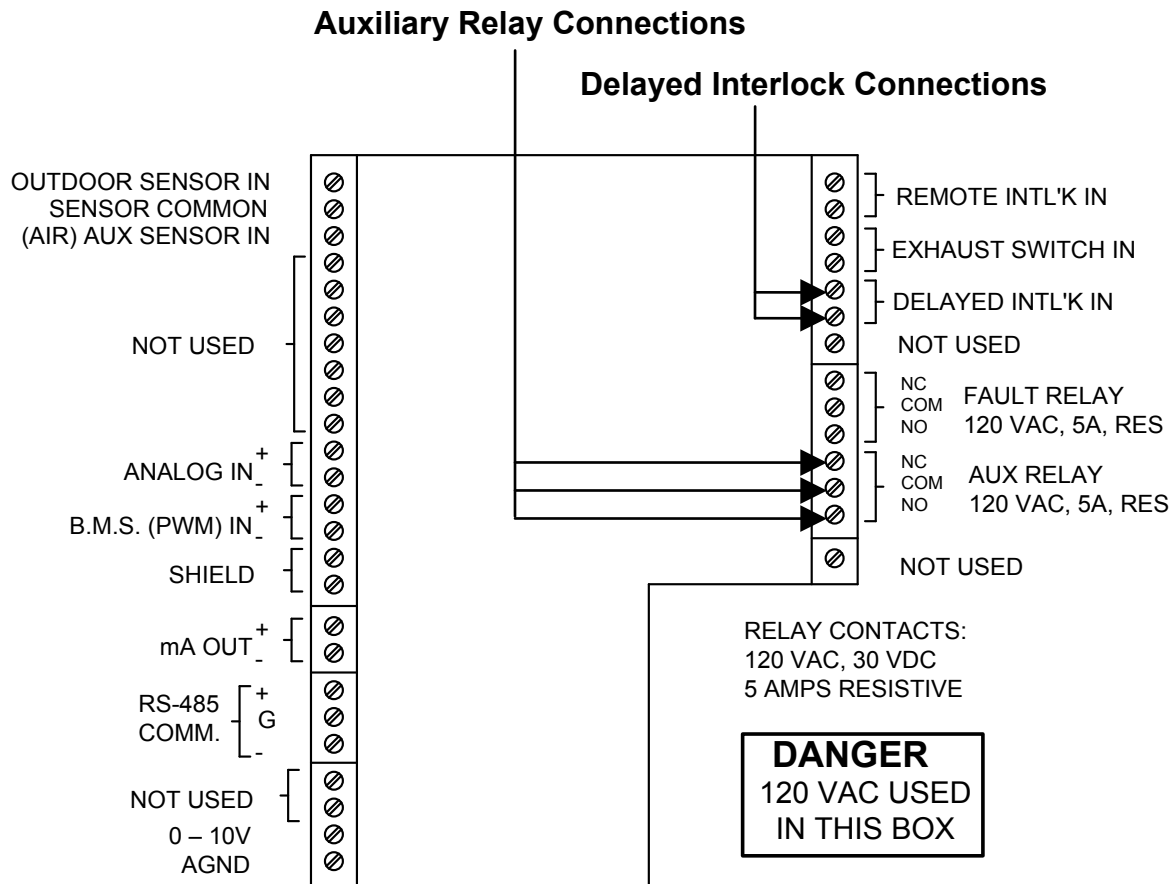

Figure 4: C-More PCB Showing Delayed and Remote Interlock Connections

3. Program the Aux Start On Delay on the C-More to allow enough time for the valve to fully open before firing the boiler. The Aux Start On Delay is located in the Configuration Menu of the C-More control system. Range is 0 to 120 seconds.
4. The BAS must incorporate a delay when closing valves once the demand is satisfied. This will allow the boiler to dissipate excess heat. Recommended delay is 2 minutes minimum. More time may be required dependent on the system design.
5. The BAS must be programmed so when there is no demand from the entire system (all boilers are off), all boiler MOVs are opened.

NOTE

For complete wiring connections, see Belimo's Installation and Maintenance Instructions shipped with the valve and also available online at:

http://www.belimo.us/belimo/media//Instructions/Installation/BFV_Instruction_Sheet.pdf

6.3 Sequence of Automation Functions

1. When a boiler is in demand, its Aux Relay will close, signaling the BAS. The Aux Start On Delay timer starts.
2. The BAS opens the MOV of the corresponding boiler.
3. When the valve has fully opened, its proof of open switch is made, closing the delayed interlock of the boiler — allowing the boiler to fire.
4. When the demand is satisfied on a corresponding boiler, the BAS will keep its valve open for at least 2 minutes before closing.
5. When there is no more demand from the entire system (all boilers are off), the BAS will open all boiler MOVs.
6. The next time there is a demand on a boiler, this sequence repeats and the BAS closes the MOV of the other boilers that have no demand.

Belimo Motorized Control Valve Warranty

The Belimo Motorized Control Valve Warranty is conditionally warranted against failure due to defect in materials for (2) two years from shipment.

AERCO shall accept no responsibility if such item has been improperly installed, operated, or maintained or if the buyer has permitted any unauthorized modification, adjustment, and/or repairs to the item.

The warranty as set forth on the back page of the Technical Instructions Document is in lieu of and not in addition to any other express or implied warranties in any documents, or under any law. No salesman or other representative of **AERCO** has any authority to expand warranties beyond the face of the said warranty and purchaser shall not rely on any oral statement except as stated in the said warranty. An Officer of **AERCO** must do any modifications to this warranty in writing. **AERCO MAKES NO WARRANTY OF MERCHANTABILITY OR FITNESS FOR PARTICULAR PURPOSE OR ANY OTHER EXPRESS OR IMPLIED WARRANTIES.** **AERCO** disclaims all responsibility for any special, incidental or consequential damages. Any claim relating to the product must be filed with **AERCO** not later than 14 days after the event-giving rise to such claim. Any claims relating to this product shall be limited to the sale price of the product at the time of sale. The sale of the product is specifically conditioned upon acceptance of these terms.

CONDITIONS OF WARRANTY:

Should a Belimo Motorized Control Valve fail for any of the above reasons within the specified time period from the date of original shipment(s), **AERCO** shall, at its option, modify, repair or exchange the defective item. **AERCO** shall have the option of having the item returned, FOB its factory, or to make field replacements at the point of installation. In no event shall **AERCO** be held liable for replacement labor charges or for freight or handling charges.

AERCO shall accept no responsibility if such item has been improperly installed, operated, or maintained or if the buyer has permitted any unauthorized modification, adjustment, and/or repairs to the item. The use of replacement parts not manufactured or sold by **AERCO** will void any warranty, express or limited.

In order to process a warranty claim, a formal purchase order number is required prior to shipment of any warranty item. In addition, the warranty must be pre-authorized by **AERCO**.

Warranty Rev: 6/10/11



© AERCO International, Inc., 2011