

1.00" - 2.00" CXT-E VALVES PARTS LIST

ITEM	QTY	DESCRIPTION	1.00 INCH	1.25 INCH	1.50 INCH	2.00 INCH
1	1	VALVE BODY	20762	20759	20758	20761
2	1	SEAT CAGE	16844	16845	16837	16843
3	1	BOTTOM PISTON	121540	121525	121502	121529
4						
5	1	VALVE PLUG SHAFT	16849	16839	16838	16848
6	1	TOP PISTON	121539	12154	121501	121530
7	1	DISC SEAT	121541	121527	121510	121531
8	1	RETAINING DISC	121542	121513	121504	121532
9						
10		PILOT SPRING	121528	121528	121528	121528
11	1	RETAINING RING	121545	121545	121545	121545
12	1	VALVE STEM	122655	122654	122651	122650
13	1	VALVE TOP GASKET	122136	122136	122136	122136
14	6	BOLT, HEX, 3/8-16	122405	122405	122405	122405
16	1	LOWER SHAFT	121979	121980	121980	121982
17	2	HEX NUT, 1/4-20	6-226	6-226	6-226	6-226
18	1	PACKING NUT	122664	122664	122664	122664
19	2	BOLT, HEX 3/8-16 x 5/8 LG	54014	54014	54014	54014
20	1	PACKING ASSY	121567	121567	121567	121567
21	1	VALVE TOP	16943	16943	16943	16943
22						
23	1	LOCKWASHER	122666	122666	122666	122666
24	1	SEAT CAGE GASKET	123080	123081	123082	123083
26	1	LINKAGE	24038-1	24038-1	24038-1	24038-1
27	1	ACTUATOR	69009	69009	69009	69009
28	1	SCALE	59028-1	59028-1.25	59028-1.5	59028-2
29	1	GASKET	81046	81046	81046	81046
30	2	NUT, HEX, #8-32	123322	123322	123322	123322
31	1	BOTTOM PISTON RETAINING NUT	122982	122982	122982	122982
32	1	TOP PISTON RETAINING NUT	121543	121543	121543	121543
33	1	LOWER PILOT SEAT ASSY	121505	121505	121505	121505

THIS PIN LOCATION TO BE USED ON ALL 1.0" TO 2.0" VALVE ASSEMBLY CONFIGURATIONS

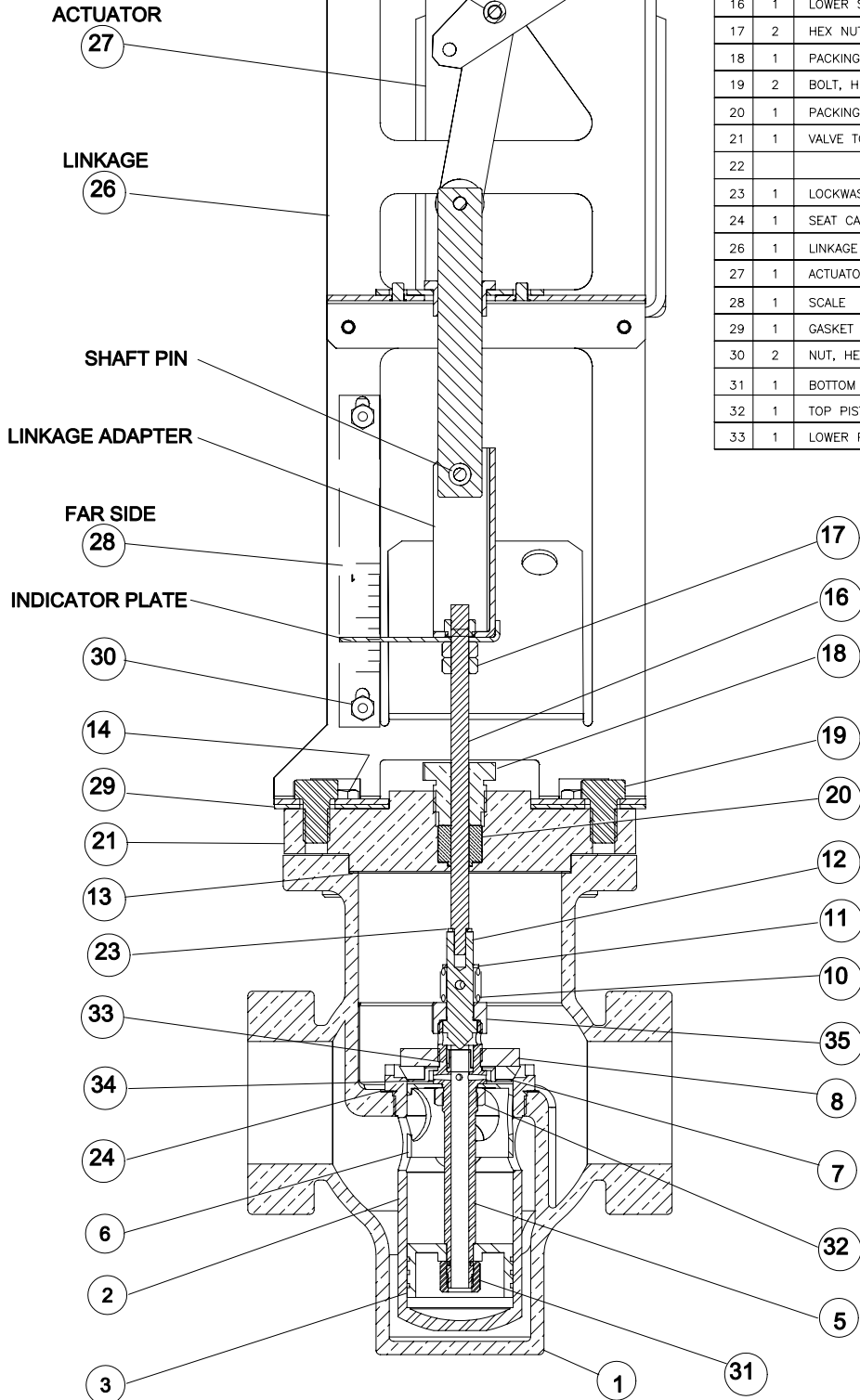

AERCO INTERNATIONAL, INC.
 NORTHVALE, NJ 07647

1.00" - 2.00" CXT-E
 ELECTRIC VALVE PARTS LIST

DWN. BY <u>CZ</u> DATE <u>050506</u>	REV. <u>A</u>
SCALE _____	PL-A-148
APPD. _____ DATE _____	