

## Installation and Startup Manual

# Benchmark<sup>®</sup> Boilers

Natural Gas, Propane Gas and Dual Fuel  
Fired Modulating & Condensing Boilers

Models 5000 and 6000



**Other documents for this product include:**

OMM-0124, GF-208 Operation-Service Manual  
TAG-0019, GF-2070 Boiler Application Guide  
TAG-0022, GF-2050 Vent-Combustion Air Guide  
TAG-0047, GF-2030 Benchmark Gas Guide  
TAG-0048, GF-2060 Benchmark Power Guide

**Applies to serial numbers:**

G-20-0001 and above

**Disclaimer**

The information contained in this manual is subject to change without notice from AERCO International, Inc. AERCO makes no warranty of any kind with respect to this material, including, but not limited to, implied warranties of merchantability and fitness for a particular application. AERCO International is not liable for errors appearing in this manual, not for incidental or consequential damages occurring in connection with the furnishing, performance, or use of these materials.

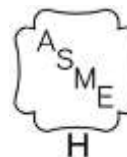

**Heating and Hot Water Solutions**

AERCO International, Inc. • 100 Oritani Drive • Blauvelt, NY 10913  
USA: T: (845) 580-8000 • Toll Free: (800) 526-0288 • AERCO.com  
Technical Support • (800) 526-0288 • Mon-Fri, 8 am - 5 pm EST  
© 2020 AERCO

# TABLE OF CONTENTS

<b>FOREWORD .....</b>	<b>5</b>
<b>SECTION 1: SAFETY PRECAUTIONS.....</b>	<b>9</b>
1.1 WARNINGS & CAUTIONS .....	9
1.2 EMERGENCY SHUTDOWN.....	10
1.3 PROLONGED SHUTDOWN.....	10
1.4 IMPORTANT – FOR MASSACHUSETTS INSTALLATIONS .....	11
<b>SECTION 2: INSTALLATION .....</b>	<b>13</b>
2.1 INTRODUCTION.....	13
2.2 RECEIVING THE UNIT.....	13
2.3 UNPACKING .....	13
2.4 SITE PREPARATION .....	14
2.4.1 Installation Clearances .....	14
2.4.2 Setting the Unit .....	16
2.4.3 LIFTING PROVISIONS .....	17
2.4.4 MULTIPLE UNIT INSTALLATIONS .....	17
2.5 SUPPLY AND RETURN PIPING .....	18
2.6 PRESSURE RELIEF VALVE INSTALLATION .....	19
2.7 PRESSURE/TEMPERATURE GAUGE INSTALLATION .....	19
2.8 CONDENSATE DRAIN AND PIPING .....	20
2.9 GAS SUPPLY PIPING .....	22
2.9.1 Gas Supply Specifications.....	22
2.9.2 Manual Gas Shutoff Valve.....	22
2.9.3 External Gas Supply Regulator .....	23
2.10 AC ELECTRICAL POWER WIRING.....	24
2.10.1 Electrical Power Requirements .....	24
2.10.2 Power Box Location.....	24
2.11 FIELD CONTROL WIRING .....	26
2.11.1 Outdoor Air & Air Sensor Common .....	27
2.11.2 AIR TEMP SENSOR .....	28
2.11.3 O <sub>2</sub> SENSOR (+ & -) .....	28
2.11.4 SPARK SIGNAL (+ & -) .....	28
2.11.5 ANALOG IN .....	28
2.11.6 VALVE FEEDBACK.....	28
2.11.7 SHIELD (SHLD & SHLD) .....	29
2.11.8 ANALOG OUT .....	29
2.11.9 RS485 Comm (+, GND, & -).....	29
2.11.10 RS232 Comm (TxD & RxD) .....	29
2.11.11 VFD/Blower (0-10 & AGND).....	29
2.11.12 Interlocks .....	29
2.11.13 Fault Relay (NC, COM, & NO) .....	30
2.11.14 Auxiliary Relay Contacts (NC, COM, & NO) .....	30
2.12 FLUE GAS VENT INSTALLATION .....	31
2.12.1 MASSACHUSETTS INSTALLATIONS .....	31
2.13 COMBUSTION AIR.....	32
2.13.1 DUCTED COMBUSTION AIR .....	32
2.14 BENCHMARK PUMP RELAY.....	32
2.15 SEQUENCING ISOLATION VALVE INSTALLATION .....	34
<b>SECTION 3: START SEQUENCE.....</b>	<b>37</b>

3.1 INTRODUCTION.....	37
3.2 START SEQUENCE .....	37
3.3 START/STOP LEVELS .....	42
3.4 START/STOP LEVELS – AIR/FUEL & ENERGY INPUT .....	42
3.4.1 Benchmark 5000 Air/Fuel Valve Position and Energy Input .....	42
3.4.2 Benchmark 6000 Air/Fuel Valve Position and Energy Input .....	43
3.5 BOILER ENERGY INPUT CHARTS .....	44
<b>SECTION 4: INITIAL START-UP.....</b>	<b>47</b>
4.1 INITIAL START-UP REQUIREMENTS .....	47
4.2 TOOLS & INSTRUMENTS FOR COMBUSTION CALIBRATION .....	48
4.2.1 Required Tools & Instrumentation .....	48
4.2.2 Installing Gas Supply Manometer .....	48
4.2.3 Accessing the Analyzer Probe Port.....	49
4.3 BENCHMARK 5000 & 6000 PILOT IGNITION .....	50
4.4 FUEL TYPES AND COMBUSTION CALIBRATION.....	50
4.5 COMBUSTION CALIBRATION.....	51
4.5.1 NATURAL GAS Combustion Calibration.....	51
4.5.2 PROPANE GAS COMBUSTION CALIBRATION.....	55
4.6 REASSEMBLY .....	58
4.7 DUAL FUEL SWITCHOVER .....	58
4.7.1 Switchover from NATURAL GAS to PROPANE .....	59
4.7.2 Switchover from PROPANE to NATURAL GAS .....	60
4.8 OVER-TEMPERATURE LIMIT SWITCHES .....	61
4.8.1 Digital Alarm Switch Checks and Adjustments .....	61
<b>SECTION 5: SAFETY DEVICE TESTING.....</b>	<b>63</b>
5.1 TESTING OF SAFETY DEVICES.....	63
5.2 LOW GAS PRESSURE TEST .....	63
5.3 HIGH GAS PRESSURE TEST .....	65
5.4 LOW WATER LEVEL FAULT TEST .....	68
5.5 WATER TEMPERATURE FAULT TEST .....	69
5.6 INTERLOCK TESTS .....	70
5.6.1 Remote Interlock Test .....	70
5.6.2 Delayed Interlock Test.....	70
5.7 FLAME FAULT TEST.....	71
5.8 AIR FLOW FAULT TESTS.....	71
5.8.1 Blower Proof Switch Test .....	72
5.8.2 Blocked Inlet Switch Test .....	73
5.9 SSOV PROOF OF CLOSURE SWITCH CHECK.....	74
5.10 PURGE SWITCH OPEN DURING PURGE.....	75
5.11 IGNITION SWITCH OPEN DURING IGNITION .....	76
5.12 SAFETY PRESSURE RELIEF VALVE TEST.....	76
<b>SECTION 6: BOILER SEQUENCING TECHNOLOGY .....</b>	<b>77</b>
6.1 INTRODUCTION.....	77
6.1.1 Installation Notes .....	78
6.2 AERCO BST QUICK START CHART.....	78
6.3 BST IMPLEMENTATION INSTRUCTION .....	79
6.3.1 OPTION 1 - Constant Setpoint With Direct Wired Header Sensor .....	79
6.3.2 OPTION 2 - Constant Setpoint With Modbus Wired Header Sensor.....	81

CONTENTS

---

6.3.3 OPTION 3 - Outdoor Reset With Direct Wired Header Sensor And Direct Wired Outdoor Sensor ..... 83

6.3.4 OPTION 4 - Outdoor Reset With Modbus Header Sensor And Modbus Outdoor Sensor..... 85

6.3.5 OPTION 5 - Remote Setpoint With Direct Wired Header Sensor And 4-20ma Setpoint Drive..... 88

6.3.6 OPTION 6 - Remote Setpoint With Direct Wired Header Sensor And Modbus Setpoint Drive ..... 90

6.3.7 OPTION 7 - Remote Setpoint With Modbus Header Sensor And 4-20ma Setpoint Drive..... 93

6.3.8 OPTION 8 - Remote Setpoint With Modbus Header Sensor And Modbus Setpoint Drive ..... 95

**APPENDIX A: DIMENSIONAL AND CLEARANCE DRAWINGS.....97**

## FOREWORD

AERCO Benchmark (BMK) 5000 MBH (1465 kW) and 6000 MBH (1758 kW) natural gas and dual fuel propane/natural gas fueled boilers are modulating and condensing units. They represent a true industry advance that meets the needs of today's energy and environmental concerns. Designed for application in any closed loop hydronic system, their modulating capability relates energy input directly to fluctuating system loads. The maximum turn down ratio for the BMK 5000 and 6000 is 15:1. These Benchmark models provide extremely high efficiency, which makes them ideally suited for modern low temperature, as well as conventional heating systems.

### IMPORTANT!

Unless otherwise specified:

- All descriptions provided in this document apply to the Benchmark Series boilers.
- All measurements apply to both natural gas and propane models, unless otherwise specified.

The Benchmark 5000 and 6000 models operate within the input and output ranges listed below.

Benchmark 5000 and 6000 Intake and Output Ranges				
MODEL	INPUT RANGE (BTU/HR.)		OUTPUT RANGE (BTU/HR.)	
	MINIMUM	MAXIMUM	MINIMUM	MAXIMUM
<b>5000</b>	400,000 (117 kW)	5,000,000 (1465 kW)	348,000 (102 kW)	4,750,000 (1392 kW)
<b>6000</b>	400,000 (117 kW)	6,000,000 (1758 kW)	348,000 (102 kW)	5,700,000 (1670 kW)

The output of the boiler is a function of the unit's firing rate (valve position) and return water temperature.

When installed and operated in accordance with this Instruction Manual, these boilers comply with the NO<sub>x</sub> emission standards outlined in: **South Coast Air Quality Management District (SCAQMD), Rule 1146.2.**

Whether used in singular or modular arrangements, BMK 5000 and BMK 6000 boilers offer the maximum venting flexibility with minimum installation space requirements. These boilers are Category II and IV, positive pressure appliances. Single and/or multiple breeched units are capable of operation in the following vent configurations:

- **Room Combustion Air:**
  - **Vertical Discharge**
  - **Horizontal Discharge**
- **Ducted Combustion Air:**
  - **Vertical Discharge**
  - **Horizontal Discharge**

These boilers are capable of being vented utilizing Polypropylene and AL29-4C vent systems.

The Benchmark's advanced electronics are available in several selectable modes of operation offering the most efficient operating methods and energy management system integration.

<b>AERCO Technical Terminology</b>	
<b>TERMINOLOGY</b>	<b>MEANING</b>
A (Amp)	Ampere
ACS	AERCO Control System, AERCO's boiler management systems
ADDR	Address
AGND	Analog Ground
ALRM	Alarm
ANSI	American National Standards Institute,
ASME	American Society of Mechanical Engineers
AUX	Auxiliary
BAS	Building Automation System, often used interchangeably with EMS (see below)
Baud Rate	Symbol rate, or simply the number of distinct symbol changes (signaling events) transmitted per second. It is not equal to bits per second, unless each symbol is 1 bit long.
BMK (Benchmark)	AERCO's Benchmark series boilers
BMS or BMS II	AERCO Boiler Management Systems
BLDG (Bldg)	Building
BST	AERCO on-board Boiler Sequencing Technology
BTU	British Thermal Unit. A unit of energy approximately equal to the heat required to raise 1 pound (0.45 kg) of water 1°F (0.55 °C)
BTU/HR	BTUs per Hour (1 BTU/hr = 0.29 W)
CCP	Combination Control Panel
CCS	Combination Control System
C-More Controller	A control system developed by AERCO and currently used in all Benchmark, Innovation and KC1000 Series product lines.
CFH	Cubic Feet per Hour (1 CFH = 0.028 m <sup>3</sup> /hr)
CO	Carbon Monoxide
COMM (Comm)	Communication
Cal.	Calibration
CNTL	Control
CPU	Central Processing Unit
DBB	Double Block and Bleed, a gas trains containing 2 Safety Shutoff Valves (SSOVs) and a solenoid operated vent valve.
DIP	Dual In-Line Package, a type of switch
ECU	Electronic Control Unit (O <sub>2</sub> sensor)
EMS	Energy Management System; often used interchangeably with BAS
FM	Factory Mutual. Used to define boiler gas trains.
GF-xxxx	Gas Fired (an AERCO document numbering system)
GND	Ground

<b>AERCO Technical Terminology</b>	
<b>TERMINOLOGY</b>	<b>MEANING</b>
HDR	Header
Hex	Hexadecimal Number (0 – 9, A – F)
HP	Horse Power
HX	Heat Exchanger
Hz	Hertz (Cycles Per Second)
I.D.	Inside Diameter
IGN	Ignition
IGST Board	Ignition/Stepper Board, contained in the C-More Controller
INTLK (INTL'K)	Interlock
I/O	Input/Output
I/O Box	Input/Output (I/O) Box currently used on Benchmark, Innovation and KC1000 Series products
IP	Internet Protocol
ISO	International Organization for Standardization
Lbs.	Pounds (1 lb = 0.45 kg)
LED	Light Emitting Diode
LN	Low Nitrogen Oxide
MA (mA)	Milliampere (1 thousand <sup>th</sup> of an ampere)
MAX (Max)	Maximum
MBH	1000 BTUs per Hour
MIN (Min)	Minimum
Modbus®	A serial, half-duplex data transmission protocol developed by AEG Modicon
NC (N.C.)	Normally Closed
NO (N.O.)	Normally Open
NO <sub>x</sub>	Nitrogen Oxide
NPT	National Pipe Thread
O <sub>2</sub>	Oxygen
O.D.	Outside Diameter
OMM & O&M	Operation and Maintenance Manual
onAER	AERCO's on-line remote monitoring system
PCB	Printed Circuit Board
PMC Board	Primary Micro-Controller (PMC) board, contained in the C-More
P/N	Part Number
POC	Proof of Closure
PPM	Parts per Million
PSI	Pounds per Square Inch (1 PSI = 6.89 kPa)
PTP	Point-to-Point (usually over RS232 networks)

<b>AERCO Technical Terminology</b>	
<b>TERMINOLOGY</b>	<b>MEANING</b>
P&T	Pressure and Temperature
ProtoNode	Hardware interface between BAS and a boiler or water heater
PVC	Poly Vinyl Chloride, a common synthetic plastic
PWM	Pulse Width Modulation
REF (Ref)	Reference
RES.	Resistive
RS232 (or EIA-232)	A standard for serial, full-duplex (FDX) transmission of data based on the RS232 Standard
RS422 (or EIA-422)	A standard for serial, full-duplex (FDX) transmission of data based on the RS422 Standard
RS485 (or EIA-485)	A standard for serial, half-duplex (HDX) transmission of data based on the RS485 Standard
RTN (Rtn)	Return
SETPT (Setpt)	Setpoint Temperature
SHLD (Shld)	Shield
SPDT	Single Pole Double Throw, a type of switch
SSOV	Safety Shut Off Valve
TEMP (Temp)	Temperature
Terminating Resistor	A resistor placed at each end of a daisy-chain or multi-drop network in order to prevent reflections that may cause invalid data in the communication
Tip-N-Tell	A device that indicates if a package was tipped during shipping
UL	A business that tests and validates products
VAC	Volts, Alternating Current
VDC	Volts, Direct Current
VFD	Vacuum Fluorescent Display, also Variable Frequency Drive
W	Watt
W.C.	Water Column, a unit of pressure (1 W.C. = 249 Pa)
µA	Micro amp (1 million <sup>th</sup> of an ampere)



## SECTION 1: SAFETY PRECAUTIONS

### 1.1 WARNINGS & CAUTIONS

Installers and operating personnel **MUST**, at all times, observe all safety regulations. The following warnings and cautions are general and must be given the same attention as specific precautions included in these instructions. In addition to all the requirements included in this AERCO Instruction Manual, the installation of units **MUST** conform with local building codes, or, in the absence of local codes, ANSI Z223.1 (National Fuel Gas Code Publication No. NFPA-54) for gas-fired boilers and ANSI/NFPA58 for LP gas-fired boilers. Where applicable, the equipment shall be installed in accordance with the current Installation Code for Gas Burning Appliances and Equipment, CSA B149.1, and applicable Provincial regulations for the class; which should be carefully followed in all cases. Authorities having jurisdiction should be consulted before installations are made.

See Section 1.4 for important information regarding installation of units within the Commonwealth of Massachusetts.

#### IMPORTANT!

This Guide is an integral part of the product and must be maintained in legible condition. It must be given to the user by the installer and kept in a safe place for future reference.

#### WARNING!

- Do not use matches, candles, flames, or other sources of ignition to check for gas leaks.
- Fluids under pressure may cause injury to personnel or damage to equipment when released. Be sure to shut off all incoming and outgoing water shutoff valves. Carefully decrease all trapped pressures to zero before performing maintenance.
- Before attempting to perform any maintenance on the unit, shut off all gas and electrical inputs to the unit.
- The exhaust vent pipe of the unit may operate under a positive pressure and therefore must be completely sealed to prevent leakage of combustion products into living spaces.
- Electrical voltages of **120, 208, 460, 575 AND 24** volts AC may be used in this equipment. Therefore the cover on the unit's power box (located behind the front panel door) must be installed at all times, except during maintenance and servicing.
- A three-pole switch must be installed on the electrical supply line of the unit. The switch must be installed in an easily accessible position to quickly and safely disconnect electrical service. Do not affix switch to unit sheet metal enclosures.

#### CAUTION!

- Many soaps used for gas pipe leak testing are corrosive to metals. The piping must be rinsed thoroughly with clean water after leak checks have been completed.
- **DO NOT** use this boiler if any part has been under water. Call a qualified service technician to inspect and replace any part that has been under water.

## 1.2 EMERGENCY SHUTDOWN

If overheating occurs or the gas supply fails to shut off, close the manual gas shutoff valve (Figure 1-1) located external to the unit.

**NOTE:**

The Installer must identify and indicate the location of the emergency shutdown manual gas valve to operating personnel.



**Figure 1-1: Manual Gas Shutoff Valve**

In addition, to ensure safety an emergency shutdown procedure that addresses the following points should be designed and implemented at the site:

- For automatically operated unattended boilers located in a boiler room, provide a manually operated remote shutdown switch or circuit breaker located just inside or outside each boiler room door. Design the system so activation of the emergency shutdown switch or circuit breaker will immediately shut off the fuel supply to the unit(s).
- For automatically operated unattended boilers in a location other than a boiler room, provide a manually operated remote shutdown switch or circuit breaker marked for easy identification at a location readily accessible in the event of boiler mis-operation.
- Design the system so activation of the emergency shutdown switch or circuit breaker will immediately shut off the fuel.
- For boilers monitored and/or operated from a continuously occupied control room, provide an emergency shutdown switch in the control room that is hard-wired to immediately shut off the fuel upon activation.

## 1.3 PROLONGED SHUTDOWN

If there is an emergency, turn off the electrical power supply to the unit and close the manual gas valve located upstream the unit. The installer must identify the emergency shut-off device.

If the boiler needs to be shut down for a prolonged period, follow the instructions in Section 4.12: *Shutting Boiler Down For Extended Period* in the *Benchmark 5000 – 6000 Operation and Maintenance Guide, OMM-0124 (GF-208)*, and review the procedures in Appendix J of the same manual.

After prolonged shutdown, it is recommended that the procedures in Section 4: *Initial Startup* and Section 5: *Safety Device Testing* of this manual be performed to verify that all system-operating parameters are correct.

## 1.4 IMPORTANT – FOR MASSACHUSETTS INSTALLATIONS

### REQUIREMENTS FOR MASSACHUSETTS INSTALLATIONS

Boiler Installations within the Commonwealth of Massachusetts must conform to the following requirements:

- Boiler must be installed by a plumber or a gas fitter who is licensed within the Commonwealth of Massachusetts.
- Prior to unit operation, the complete gas train and all connections must be leak tested using a non-corrosive soap.
- The vent termination must be located a minimum of 4 feet above grade level. If side-wall venting is used, the installation must conform to the following requirements **extracted from 248 CMR 5.08 (2)**:

(a) For all side wall horizontally vented gas fueled equipment installed in every dwelling, building or structure used in whole or in part for residential purposes, including those owned or operated by the Commonwealth and where the side wall exhaust vent termination is less than seven (7) feet above finished grade in the area of the venting, including but not limited to decks and porches, the following requirements shall be satisfied:

**1. INSTALLATION OF CARBON MONOXIDE DETECTORS:** At the time of installation of the side wall horizontal vented gas fueled equipment, the installing plumber or gasfitter shall observe that a hard wired carbon monoxide detector with an alarm and battery back-up is installed on the floor level where the gas equipment is to be installed. In addition, the installing plumber or gasfitter shall observe that a battery operated or hard wired carbon monoxide detector with an alarm is installed on each additional level of the dwelling, building or structure served by the side wall horizontal vented gas fueled equipment. It shall be the responsibility of the property owner to secure the services of qualified licensed professionals for the installation of hard wired carbon monoxide detectors.

**a.** In the event that the side wall horizontally vented gas fueled equipment is installed in a crawl space or an attic, the hard wired carbon monoxide detector with alarm and battery back-up may be installed on the next adjacent floor level.

**b.** In the event that the requirements of this subdivision can not be met at the time of completion of installation, the owner shall have a period of thirty (30) days to comply with the above requirements; provided, however, that during said thirty (30) day period, a battery operated carbon monoxide detector with an alarm shall be installed.

**2. APPROVED CARBON MONOXIDE DETECTORS:** Each carbon monoxide detector as required in accordance with the above provisions shall comply with NFPA 720 and be ANSI/UL 2034 listed and IAS certified.

**3. SIGNAGE:** A metal or plastic identification plate shall be permanently mounted to the exterior of the building at a minimum height of eight (8) feet above grade directly in line with the exhaust vent terminal for the horizontally vented gas fueled heating appliance or equipment. The sign shall read, in print size no less than one-half (1/2) inch in size, "**GAS VENT DIRECTLY BELOW. KEEP CLEAR OF ALL OBSTRUCTIONS**". (Continued)

**REQUIREMENTS FOR MASSACHUSETTS INSTALLATIONS**

**4. INSPECTION:** The state or local gas inspector of the side wall horizontally vented gas fueled equipment shall not approve the installation unless, upon inspection, the inspector observes carbon monoxide detectors and signage installed in accordance with the provisions of 248 CMR 5.08(2)(a)1 through 4.

(b) **EXEMPTIONS:** The following equipment is exempt from 248 CMR 5.08(2)(a)1 through 4:

1. The equipment listed in Section 10 entitled "Equipment Not Required To Be Vented" in the most current edition of NFPA 54 as adopted by the Board; and
2. Product Approved side wall horizontally vented gas fueled equipment installed in a room or structure separate from the dwelling, building or structure used in whole or in part for residential purposes.

(c) **MANUFACTURER REQUIREMENTS - GAS EQUIPMENT VENTING SYSTEM PROVIDED.** When the manufacturer of Product Approved side wall horizontally vented gas equipment provides a venting system design or venting system components with the equipment, the instructions provided by the manufacturer for installation of the equipment and the venting system shall include:

1. Detailed instructions for the installation of the venting system design or the venting system components; and
2. A complete parts list for the venting system design or venting system.

(d) **MANUFACTURER REQUIREMENTS - GAS EQUIPMENT VENTING SYSTEM NOT PROVIDED.** When the manufacturer of a Product Approved side wall horizontally vented gas fueled equipment does not provide the parts for venting the flue gases, but identifies "special venting systems", the following requirements shall be satisfied by the manufacturer:

1. The referenced "special venting system" instructions shall be included with the appliance or equipment installation instructions; and
2. The "special venting systems" shall be Product Approved by the Board, and the instructions for that system shall include a parts list and detailed installation instructions.

(e) A copy of all installation instructions for all Product Approved side wall horizontally vented gas fueled equipment, all venting instructions, all parts lists for venting instructions, and/or all venting design instructions shall remain with the appliance or equipment at the completion of the installation.

.....[End of Extracted Information From 248 CMR 5.08 (2)].....

## SECTION 2: INSTALLATION

### 2.1 INTRODUCTION

This section provides the descriptions and procedures necessary to unpack, inspect and install the AERCO 5000 and 6000 Benchmark boilers.

### 2.2 RECEIVING THE UNIT

Each Benchmark boiler is shipped as a single crated unit. The shipping weight for the BMK 5000 and 6000 models is approximately 3500 pounds (1588 kg).

The unit must be moved with the proper rigging equipment for safety and to avoid equipment damage. The unit should be completely inspected for evidence of shipping damage and shipment completeness at the time of receipt from the carrier and before the bill of lading is signed.

**NOTE:**

AERCO is not responsible for lost or damaged freight. Check for indications that the unit has been turned on its side during shipment. If you see any such signs, do not sign for the shipment. Note the information on the carrier's paperwork and request a freight claim and inspection by a claims adjuster before proceeding. Any other visual damage to the packaging materials should also be made clear to the delivering carrier.

### 2.3 UNPACKING

The unit is shipped mounted on a skid and shrouded in a plastic wrap. It can be moved while on the skid using a forklift.

Carefully remove the plastic wrap from the unit taking care not to damage the unit enclosure panels when cutting away the plastic wrap.

After unpacking, make a close inspection of the unit to ensure there is no evidence of damage. The freight carrier should be notified immediately if any damage is detected.

The following accessories come standard with each unit and are either packed separately within the unit's shipping container or are factory installed on the unit:

- **Pressure/Temperature Gauge**
- **ASME Pressure Relief Valve**
- **Condensate Drain Trap (P/N 24441)**
- **2" Natural Gas Supply Shutoff Valve, and a Propane Shutoff Valve on Propane and Dual Fuel units**

When optional accessories are ordered, they may be packed within the unit's shipping container, factory installed on the unit, or packed and shipped in a separate container. Any standard or optional accessories shipped loose should be identified and stored in a safe place until ready for installation or use.



**Figure 2-1: Benchmark 5000/6000 Mounted on Shipping Skid**

## 2.4 SITE PREPARATION

Ensure that the site selected for installation of the Benchmark boiler includes access to:

- One of the following AC Input Power:
  - 208 VAC, Three-Phase, 60 Hz @ 30 Amps
  - 460 VAC, Three-Phase, 60 Hz @ 20 Amps
  - 575 VAC, Three-Phase, 60 Hz @ 20 Amps
- **NATURAL GAS – standard pressure models:** Access to a 2 inch (5.08 cm) line with a **minimum** pressure of **14 inches W.C. (3.49 kPa) with the unit at FULL FIRE**
- **NATURAL GAS – Low Gas Pressure (LGP) models:** Access to a 3 inch (7.62 cm) line with a **minimum** pressure of **4 inches W.C. (1.0 kPa) with the unit at FULL FIRE**
- **PROPANE GAS** (Dual Fuel and Propane only units): Access to a 1-1/2 inch (3.81 cm) line with a **minimum** pressure of **14 inches W.C. (3.49 kPa) with the unit at FULL FIRE**

### 2.4.1 Installation Clearances

Benchmark 5000 and 6000 boiler dimensions and minimum acceptable clearances are shown in Figure 2-2. The minimum clearance dimensions, required by AERCO, are listed below. However, if Local Building Codes require additional clearances, these codes shall supersede AERCO's requirements. Minimum acceptable clearances required are as follows:

- Front : 36 inches (91 cm)
- Sides: 24 inches (61 cm)
- Rear: 24 inches (61 cm)
- Top: 18 inches (45.7 cm)

**SECTION 2: INSTALLATION**

All gas piping, water piping and electrical conduit or cable must be arranged so that they do not interfere with the removal of any panels, or inhibit service or maintenance of the unit.

**NOTE:**

Benchmark 5000 and 6000 units may be installed with zero side clearances in pairs only. The perimeter clearances still apply (see Figure 2-2 and the drawings in *Appendix A: Dimensional Drawings*).

**IMPORTANT!**

Ensure that adequate clearance exists at the rear of the unit to permit installation and service maintenance of the AERCO Condensate Trap. Refer to Section 2.8 for Condensate Trap installation details.

When using the AERCO Condensate Neutralizer Tank for condensate drainage, the tank must be installed in a pit, OR the boiler and AERCO Condensate Trap must be elevated higher than 4" (10.2 cm) above the floor. See Condensate Neutralizer Tank Instructions TID-0074 for details.

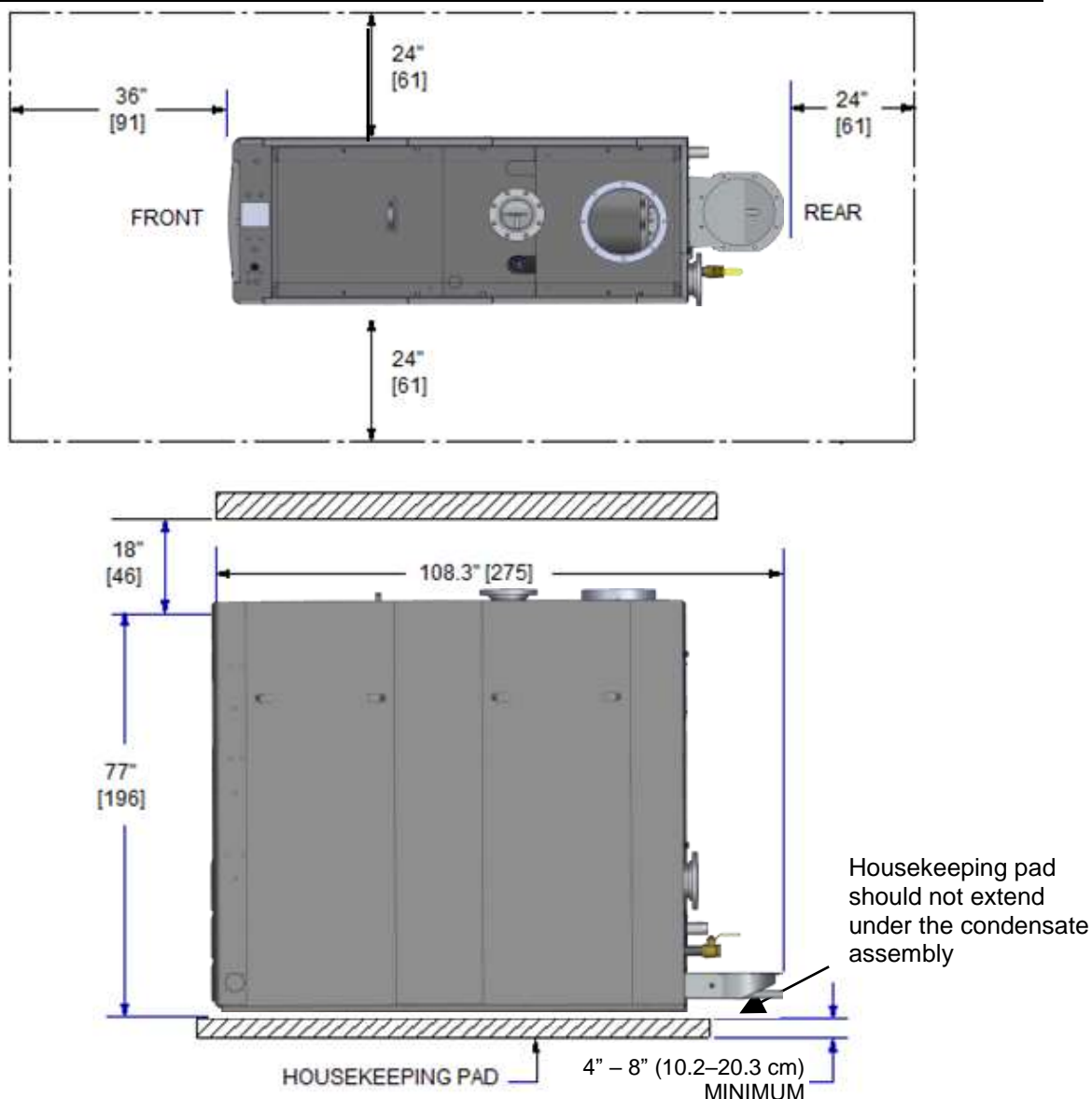

**Figure 2-2: Benchmark Model 5000 & 6000 Clearances**

**WARNING!**

Keep the unit area clear and free from all combustible materials and flammable vapors or liquids.

**FOR MASSACHUSETTS ONLY:**

For Massachusetts installations, the unit must be installed by a plumber or gas-fitter licensed within the Commonwealth of Massachusetts. In addition, the installation must comply with all requirements specified in Section 1.4, above.

**2.4.2 Setting the Unit**

Benchmark 5000 and 6000 units must be installed on a level **4 to 8 inch (10.2 to 20.3 cm)** thick housekeeping pad to ensure proper condensate drainage. If anchoring the unit, refer to Figure 2-3 for anchor locations.

**NOTE:**

When using the AERCO Condensate Neutralizer Tank for proper condensate drainage, the Neutralizer Tank must be stored in a pit, OR the boiler and AERCO Condensate Trap must be **elevated higher than 4" (10.2 cm)** above the floor. Ensure that the condensate assembly is not positioned above the housekeeping pad during installation so as not to interfere with condensate piping. See Condensate Tank Instructions TID-0074 for details.

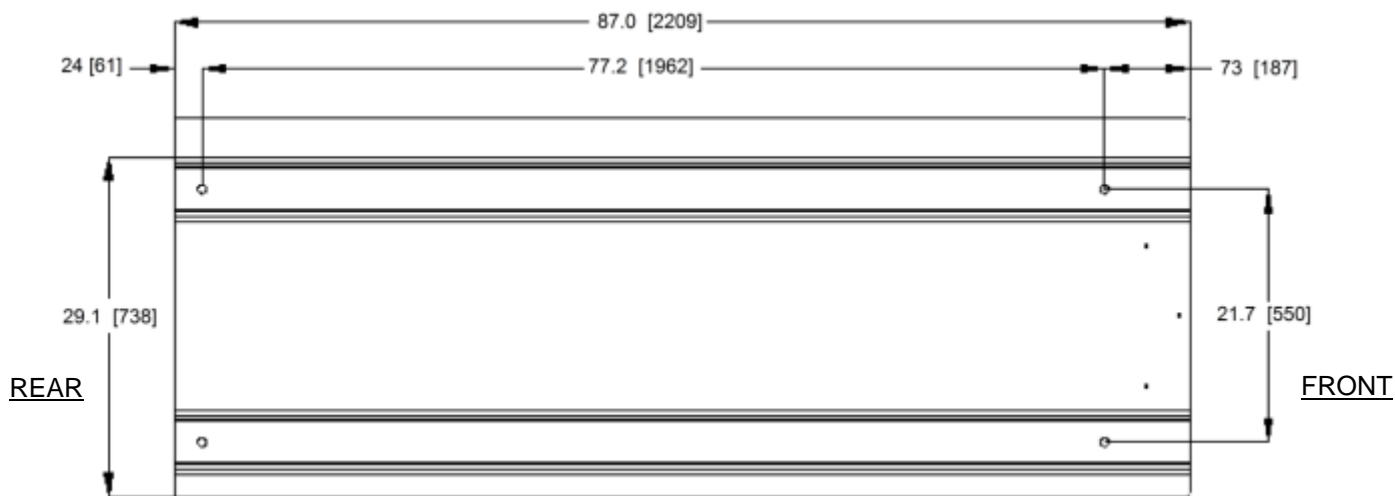

- All holes are flush with the bottom surface of the frame.
- All dimensions shown are in inches [millimeters]

**Figure 2-3. Benchmark 5000 and 6000 Anchor Bolt Locations**



### 2.4.3 LIFTING PROVISIONS

Two (2) lifting lugs are provided at the top of the primary heat exchanger as shown in Figure 2-4. The location of the lifting tabs is marked on the shrink-wrap coving the unit for shipping.

Remove the four (4) lag screws securing the unit to the shipping skid, and, if still in place, remove the front Top Panel. Lift the unit off the shipping skid using a spreader bar and position it on the (required) concrete Housekeeping Pad in the desired location.

#### WARNING!

When lifting or moving the boiler, do not attempt to manipulate the unit using the gas train or blower. A spreader bar is required for all vertical lifts. Failure to use a spreader bar can put excessive force on the unit and can cause boiler failure.

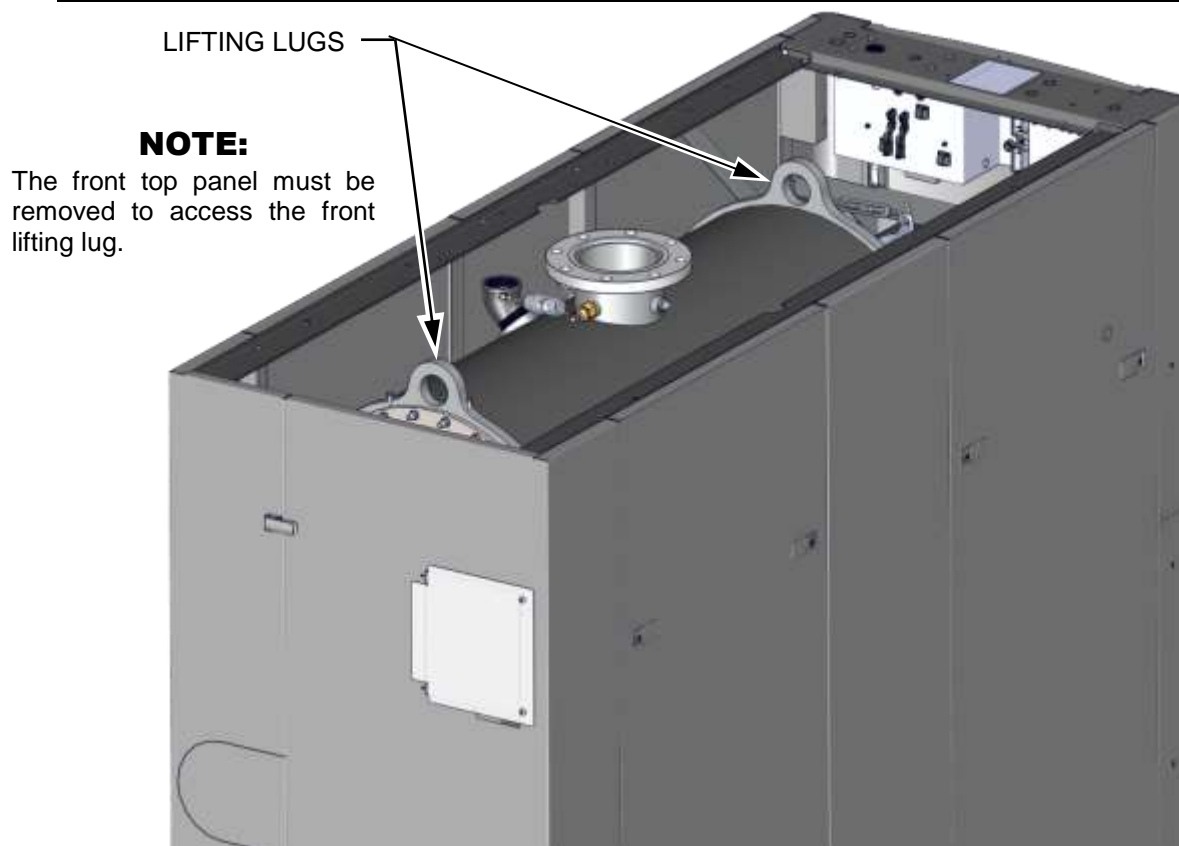

*Figure 2-4: Lifting Lug Locations*

### 2.4.4 MULTIPLE UNIT INSTALLATIONS

In multiple unit installations, it is important to plan the position of each unit in advance. Sufficient space for piping connections and future service/maintenance requirements must also be taken into consideration. All piping must include ample provisions for expansion.

## 2.5 SUPPLY AND RETURN PIPING

The Benchmark 5000 and 6000 boiler utilizes 6" (15.24 cm) flanged fittings for the water system supply and return piping connections. The physical location of the supply and return piping connections are shown in Figure 2-5. Refer to *Appendix A: Dimensional and Clearance Drawings* for additional dimensional data.

When connecting the hot water outlet and cold water inlet to building piping, first make sure the mating surfaces are thoroughly clean. AERCO recommends using Loctite® 7649 to prime the mating surfaces and then Loctite 567 as pipe dope. **Do NOT use Teflon tape.**

See Sections 2.12 and 2.13 for information on the flue vent and air intake.

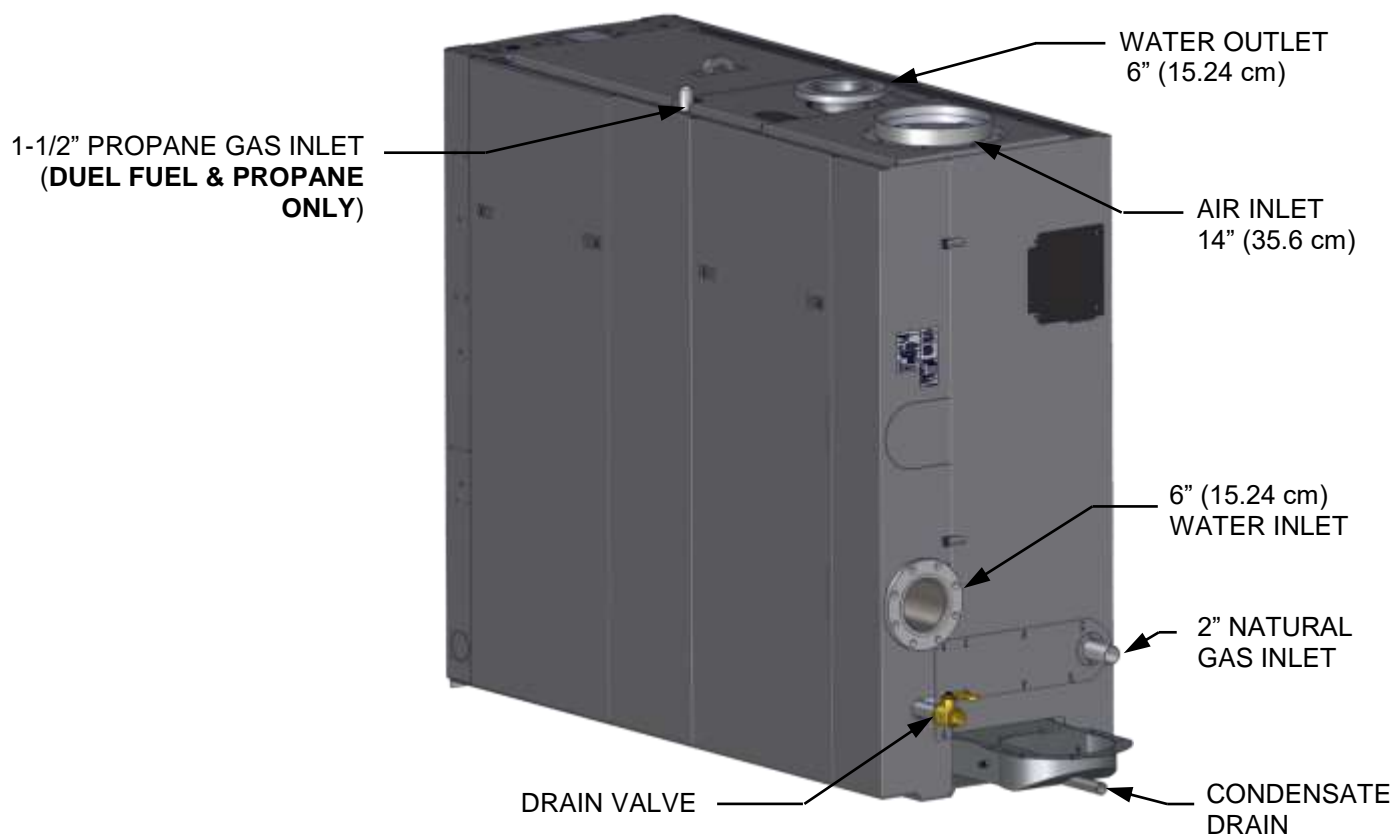

**Figure 2-5: Supply and Return Locations (Dual Fuel Model Shown)**

## 2.6 PRESSURE RELIEF VALVE INSTALLATION

Depending on the pressure required, Benchmark 5000 and 6000 boilers are supplied with an ASME rated Pressure Relief Valves. The pressure relief valve supplied with the boiler must be installed to meet code and safety requirements. The pressure rating for the relief valve must be specified on the sales order. Available pressure ratings range from **30 to 160 psi (207 to 1034 kPa)**. The pressure relief valve is furnished as a kit (P/N **58053-TAB**), which consists of the relief valve for the pressure rating specified on the Sales Order. The appropriate size reducing bushing and nipple are also included in the kit. The pressure relief valve, nipples and bushings are connected to 45° street elbows already installed on the heat exchanger of the boiler. The relief valve is installed on the top of the boiler as shown in Figure 2-6. A suitable pipe joint compound should be used on all threaded connections. Any excess should be wiped off to avoid getting any joint compound into the valve body. The relief valve must be piped to **within 12 inches (30.5 cm) of the floor** to prevent injury in the event of a discharge. The discharge piping must be full size, without reduction. No valve or size reductions are allowed in the full port discharge line. In multiple unit installations, the discharge lines must NOT be manifolded together; each must be individually run to a suitable discharge location.

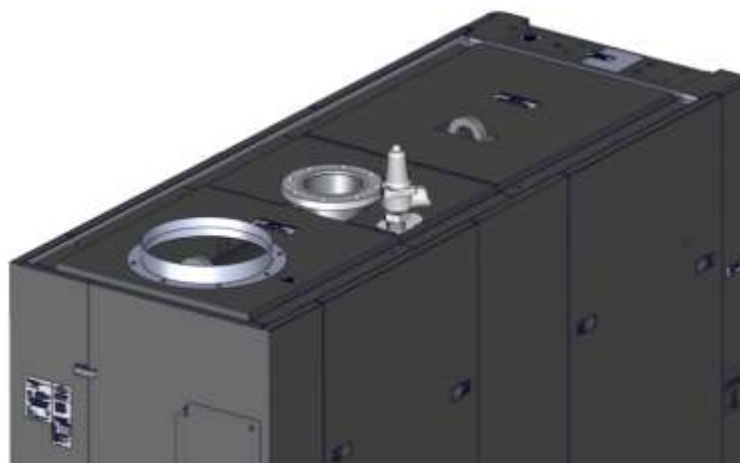

*Figure 2-6. Pressure Relief Valve Installation Location*

## 2.7 PRESSURE/TEMPERATURE GAUGE INSTALLATION

A Pressure/Temperature Gauge is included in the loose parts kit for installation in the boiler outlet piping. It must be installed so that the sensing bulb is inserted into the hot water outlet flow from the boiler. Refer to Figure 2-7 for sample installations.

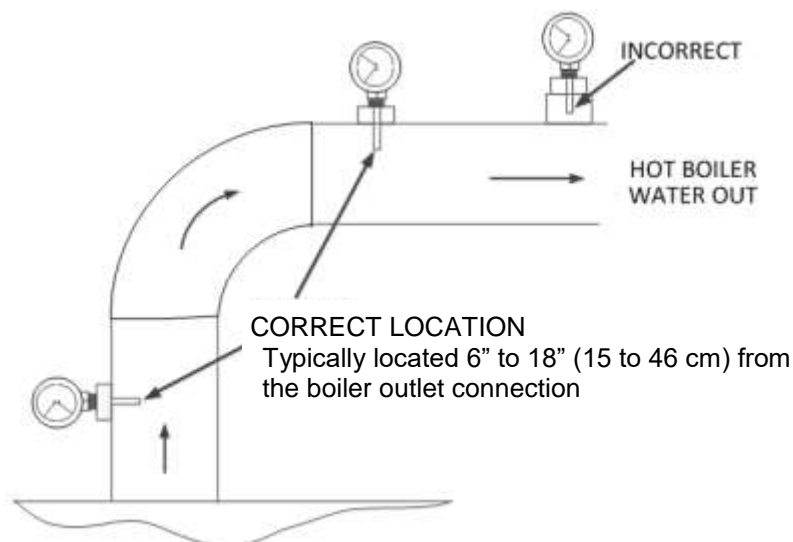

Figure 2-7: *Pressure/Temperature Gauge Installation Location*

## 2.8 CONDENSATE DRAIN and PIPING

The Benchmark Boiler is designed to condense water vapor from the flue products. Therefore, the installation must have provisions for suitable condensate drainage or collection.

The condensate drain port is located on the exhaust manifold (Figure 2-8) at the rear of the unit. This drain port must be connected to the condensate trap (P/N **24441**), which is packed separately within the unit's shipping container. The condensate trap outlet connection features a tapped 3/4" NPT drain port.

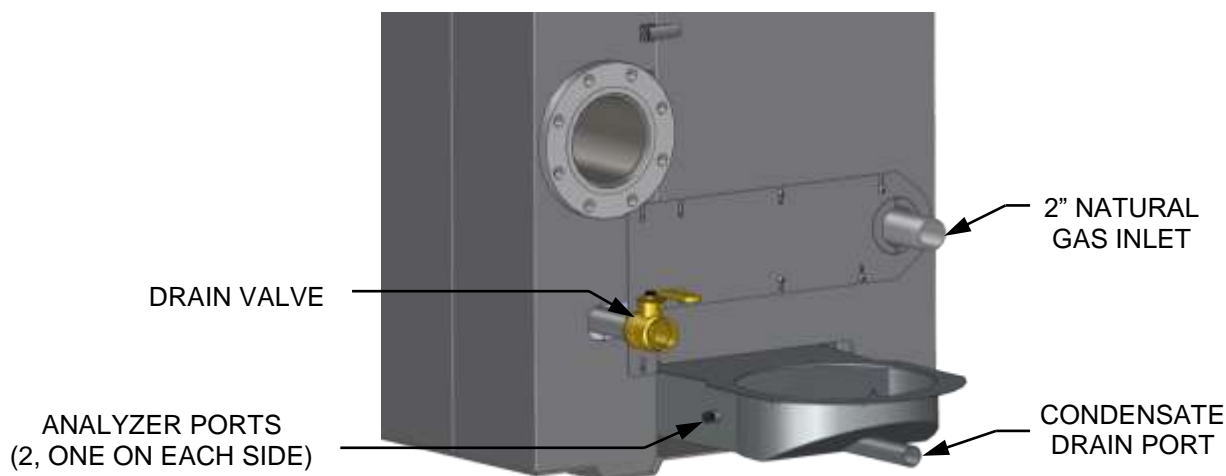

Figure 2-8: *Condensate Drain Connection Location*

A sample condensate trap installation is shown in Figure 2-9. However, the actual installation details for the trap will vary depending on the available clearances, housekeeping pad height and dimensions and other prevailing conditions at the site. The following general guidelines must be observed to ensure proper condensate drainage:

- The condensate trap inlet (Figure 2-9) must be level with, or lower than the exhaust manifold condensate drain port.
- The base of the condensate trap must be supported to ensure that it is level (horizontal).

**SECTION 2: INSTALLATION**

- The trap must be removable for routine maintenance. AERCO recommends that a union be utilized between the exhaust manifold condensate drain port and the trap inlet port.

While observing the above guidelines, install the condensate trap as follows:

**Condensate Drain Installation Instructions**

1. Connect the condensate trap inlet to the exhaust manifold drain connection using the appropriate piping components (nipples, reducers, elbows, etc.) for the site.
2. At the condensate trap outlet, install a 3/4" NPT nipple.
3. Connect a length of 1" (2.54 cm) I.D. polypropylene hose to the trap outlet and secure with a hose clamp.
4. Route the hose on the trap outlet to a nearby floor drain.

If a floor drain is not available, a condensate pump can be used to remove the condensate to drain. The maximum condensate flow rate is **40 gallons (151 liters) per hour**.

The condensate drain trap, associated fittings and drain line must be removable for routine maintenance.

**WARNING!**

Use PVC, stainless steel, aluminum or polypropylene for condensate drain piping. **DO NOT** use carbon or copper components.

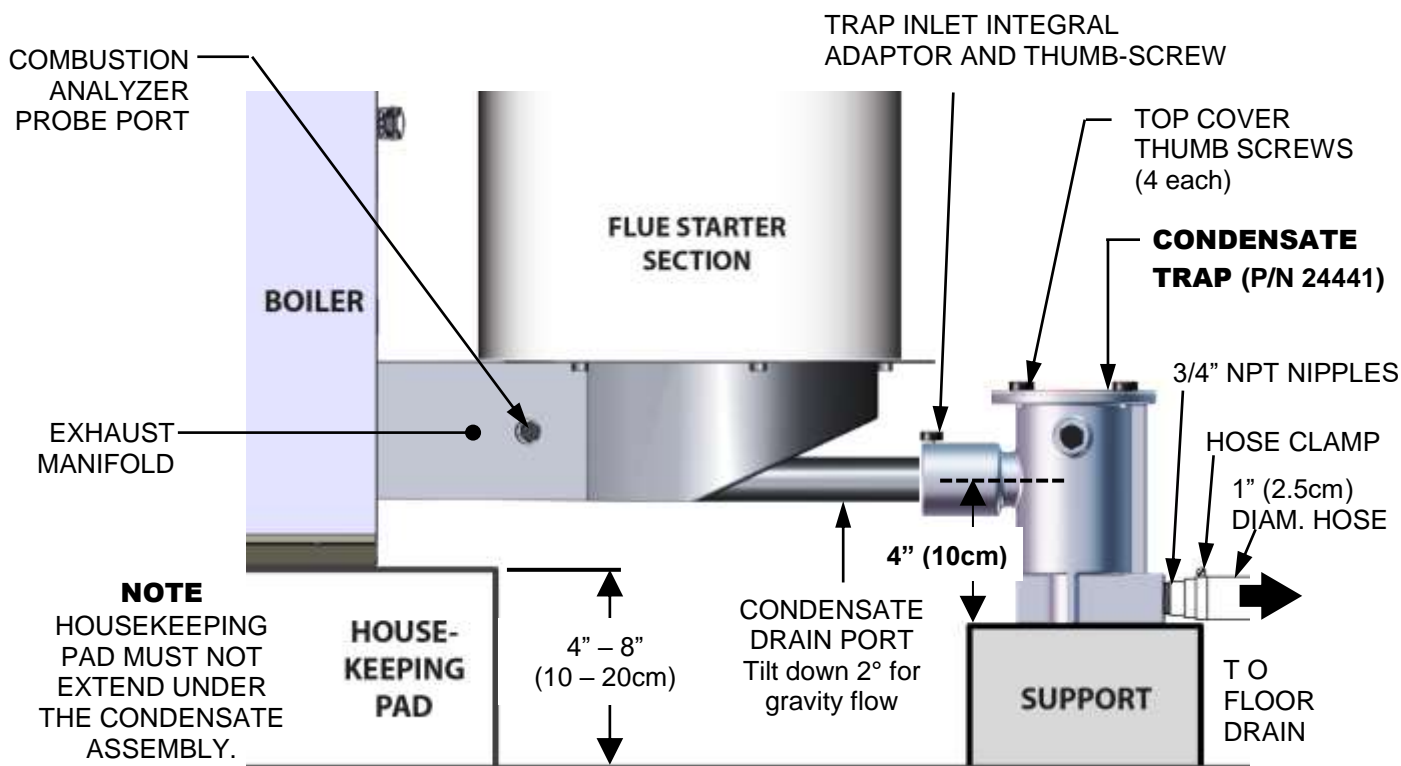

Figure 2-9: Sample Condensate Trap Installation

## 2.9 GAS SUPPLY PIPING

AERCO's *Benchmark Gas Components and Supply Design Guide*, TAG-0047 (GF-2030) must be consulted prior to designing or installing any gas supply piping.

**WARNING!**  
NEVER USE MATCHES, CANDLES, FLAMES OR OTHER SOURCES OF IGNITION TO CHECK FOR GAS LEAKS.

**CAUTION!**  
Many of the soaps used for gas pipe leak testing are corrosive to metals. Therefore, piping must be rinsed thoroughly with clean water after leak checks have been completed.

**NOTE:**  
All gas piping must be arranged so that it does not interfere with removal of any covers, inhibit service/maintenance, or restrict access between the unit and walls, or another unit.

Natural Gas Piping	Propane Piping
2" (5.08 cm) in back of unit 3" (7.62 cm) LGP units, in back of unit	1-1/2" (3.81 cm) on top of unit

Prior to installation, all pipes should be de-burred and internally cleared of any scale, metal chips or other foreign particles. Do *NOT* install any flexible connectors or unapproved gas fittings. Piping must be supported from the floor, ceiling or walls only and must not be supported by the unit.

A suitable piping compound, approved for use with natural gas, should be used. Any excess must be wiped off to prevent clogging of components.

To avoid unit damage when pressure testing gas piping, isolate the unit from the gas supply piping. A thorough leak test of all external piping must be performed using a soap and water solution or suitable equivalent. The gas piping used must meet all applicable codes.

### 2.9.1 Gas Supply Specifications

AERCO Benchmark Low NOx series boilers require a stable natural gas and propane input pressure. It must comply with the allowable gas inlet pressure range specified in the *Benchmark Pre-Installation Gas Supply Guide* (TAG-0047, GF-2030).

### 2.9.2 Manual Gas Shutoff Valve

A manual shut-off valve must be installed in the gas supply line upstream of the boiler, as shown in Figure 2-10.

### 2.9.3 External Gas Supply Regulator

An external gas pressure regulator is required on the gas inlet piping under most conditions (see sections 2.9.3.1 and 2.9.3.2, below). Regulators must conform to the following specifications:

An external gas pressure regulator is required on the gas inlet piping under most conditions. Regulators must conform to the following specifications:

- The external natural gas regulator must be capable of regulating 300,000 – 6,000,000 BTU/Hr (88 – 1758 kW) of natural gas while maintaining a **minimum gas pressure of 14" W.C. (3.49 kPa)** to the unit. (This does not apply to Low Gas Pressure (LGP) models running at **4" W.C. (1.0 kPa)** minimum to the unit.)
- A lock-up style regulator **MUST** be used.

#### 2.9.3.1 Massachusetts Installations Only

For Massachusetts installations, a mandatory external gas supply regulator must be positioned as shown in Figure 2-10. The gas supply regulator must be properly vented to outdoors. Consult the local gas utility for detailed requirements concerning venting of the supply gas regulator.

#### 2.9.3.2 All Installations (Except Massachusetts)

For installations with 3 or more units (other than Massachusetts) that **exceed 1 PSI (6.9 kW)** gas pressure, a separate external gas supply regulator, as shown in Figure 2-10, is highly recommended. No regulator is required for gas pressures **below 1 PSI (6.9 kW)** of pressure, **but above 2 PSI (13.8 kW) it is mandatory**. Consult the *Benchmark Gas Supply Design Guide*, TAG-0047, GF-2030, and the local gas utility for detailed requirements concerning venting of the supply gas regulator.

#### NOTE:

It is the responsibility of the customer to source and purchase the appropriate gas regulator as described above. However, AERCO offers for sale an appropriate regulator, which may be ordered at the time of unit purchase or separately. Contact your AERCO sales representative for more information.

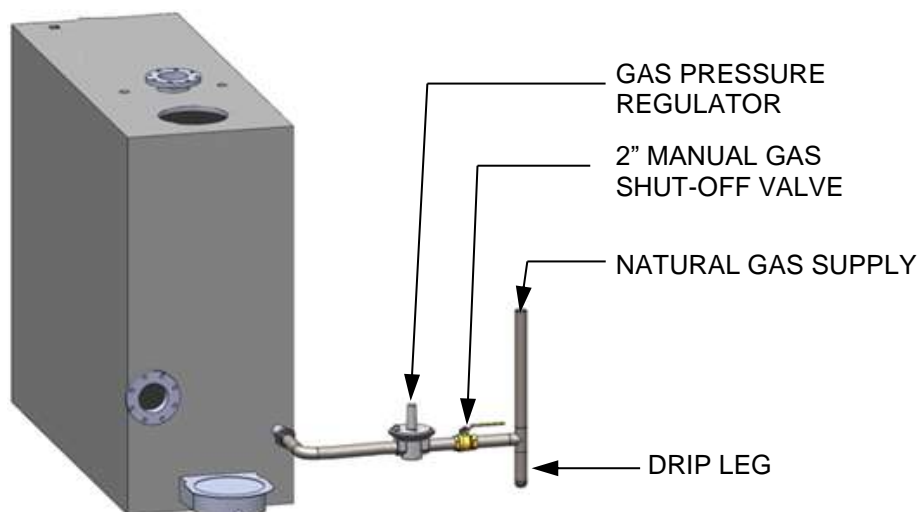

**Figure 2-10a: Manual Gas Shut-Off Valve Location – Single Fuel**

## SECTION 2: INSTALLATION

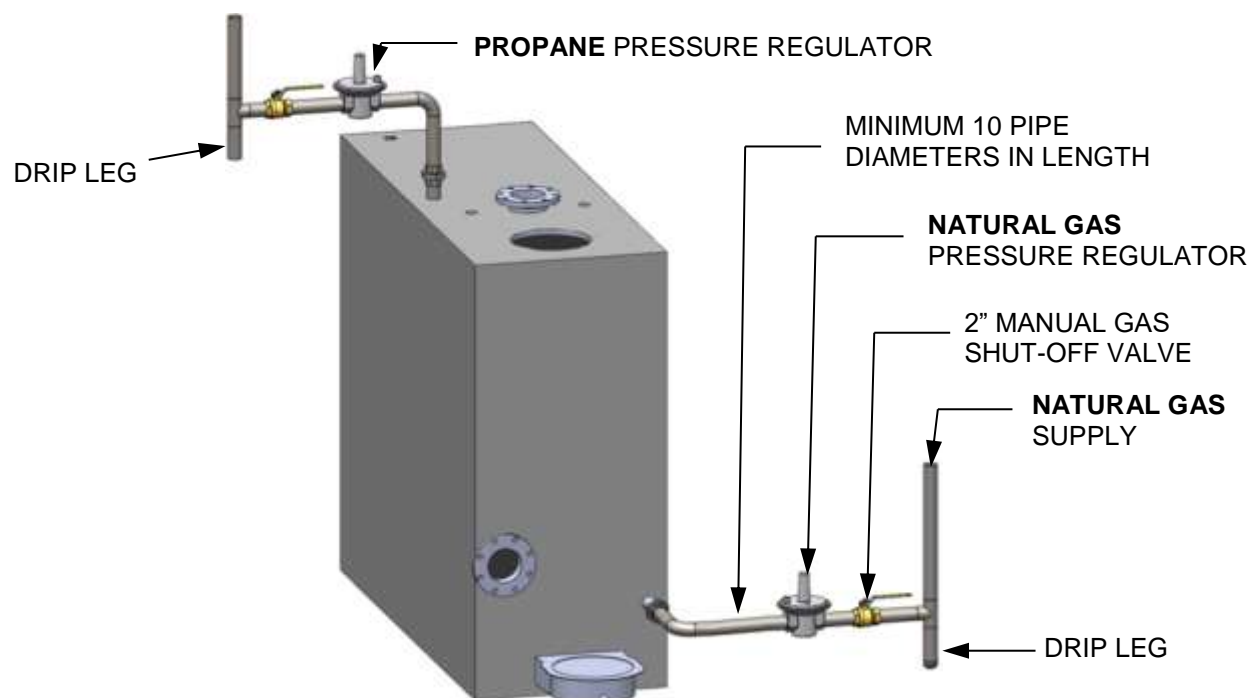

**Figure 2-10b: Manual Gas Shut-Off Valve Location – Dual Fuel Shown**

## 2.10 AC ELECTRICAL POWER WIRING

For electrical power requirements and wiring diagrams for Benchmark Platinum 5000 and – 6000 units, both domestic and international, see the AERCO's *Benchmark Electrical Power Guide*, TAG-0048 (GF-2060). This guide must be consulted prior to connecting any AC power wiring to the unit.

### 2.10.1 Electrical Power Requirements

Each unit must be connected to a dedicated electrical circuit. **NO OTHER DEVICES SHOULD BE ON THE SAME ELECTRICAL CIRCUIT AS THE BOILER.**

A double-pole switch must be installed on the electrical supply line in an easily accessible location to quickly and safely disconnect electrical service. DO NOT attach the switch to sheet metal enclosures of the unit.

After placing the unit in service, the ignition safety shutoff device must be tested. If an external electrical power source is used, the installed boiler must be electrically bonded to ground in accordance with the requirements of the authority having jurisdiction. In the absence of such requirements, the installation shall conform to National Electrical Code (NEC), ANSI/NFPA 70 and/or the Canadian Electrical Code (CEC) Part I, CSA C22.1 Electrical Code.

### 2.10.2 Power Box Location

External AC power connections are made to the unit inside the Power Box on the front of the unit. Remove the front panel to access the Power Box, which is mounted in the upper right corner of the unit as shown in Figure 2-11. Loosen the two upper screws of the Power Box cover and remove cover to access the internal connections shown in Figure 2-12.



SECTION 2: INSTALLATION

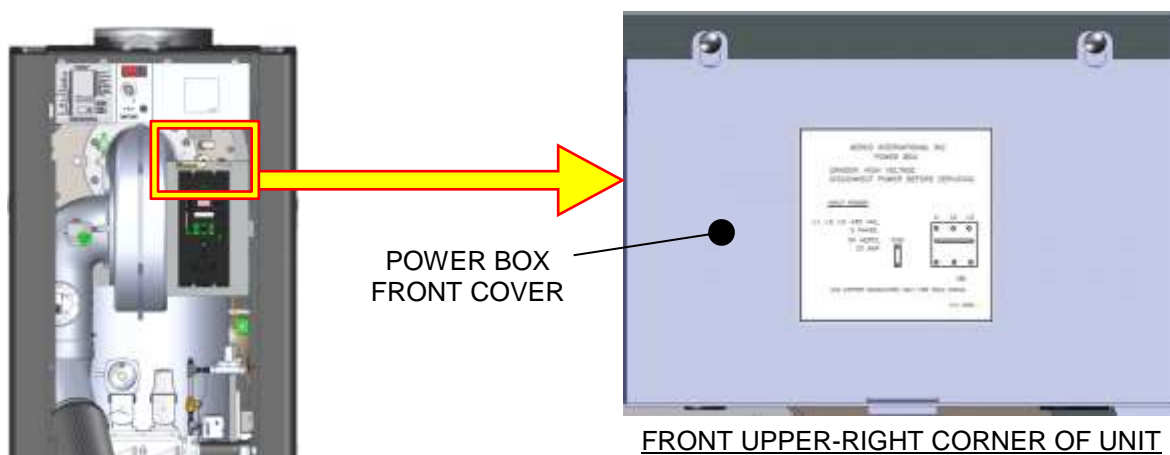

**Figure 2-11: Power Box with Closed Cover**

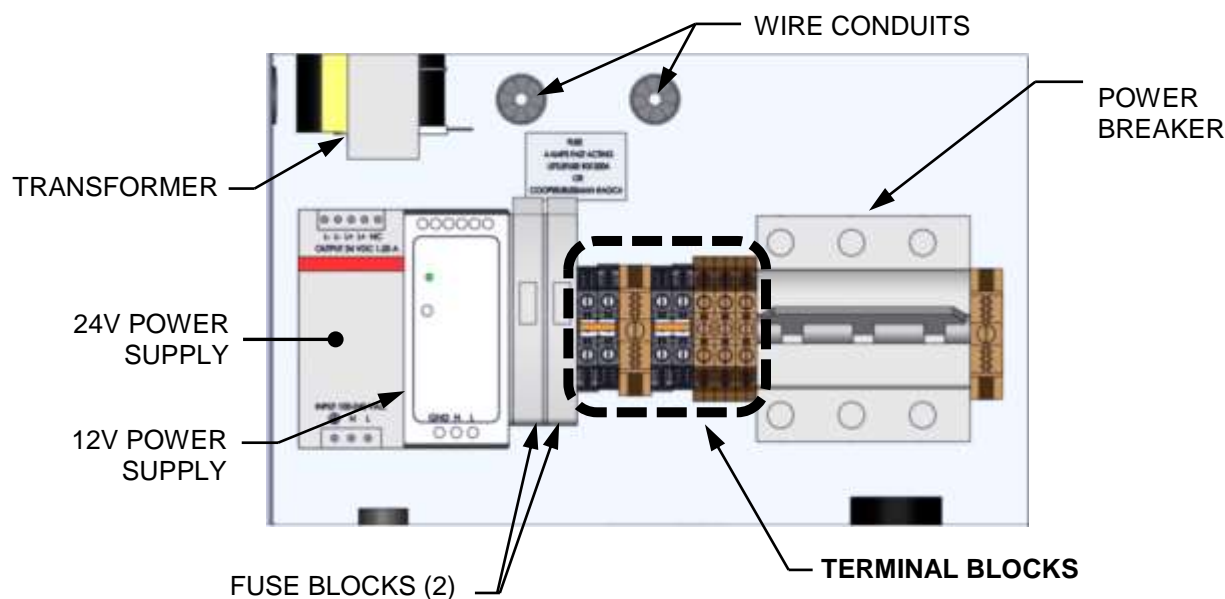

**Figure 2-12: Power Box Internal Components (Cover Removed)**

The Power Box contains terminal blocks as shown in Figure 2-12. With the exception of the transformer, all of the components in the Power Box are mounted on a DIN rail.

**NOTE:**

All electrical conduit and hardware must be installed so that it does not interfere with the removal of any unit covers, inhibit service/maintenance, or prevent access between the unit and walls or another unit.

## 2.11 FIELD CONTROL WIRING

Each unit is fully wired from the factory with an internal operating control system. No field control wiring is required for normal operation. However, the C-More Controller used with all Benchmark units does allow for some additional control and monitoring features. Wiring connections for these features are made on the Input/Output (I/O) board located behind unit's removable front panel. The I/O board is located in the I/O Box. The I/O board terminal strip connections are shown in Figure 2-14. All field wiring is installed from the rear of the panel by routing the wires through one of the four bushings provided on the sides of the I/O box.

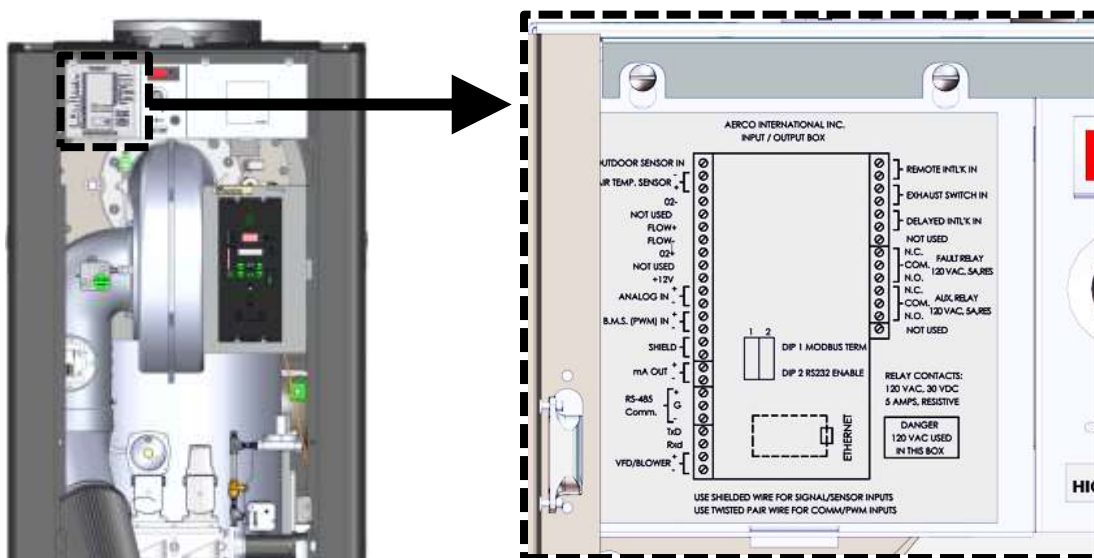

**Figure 2-13a: Input/Output (I/O) Box Location**

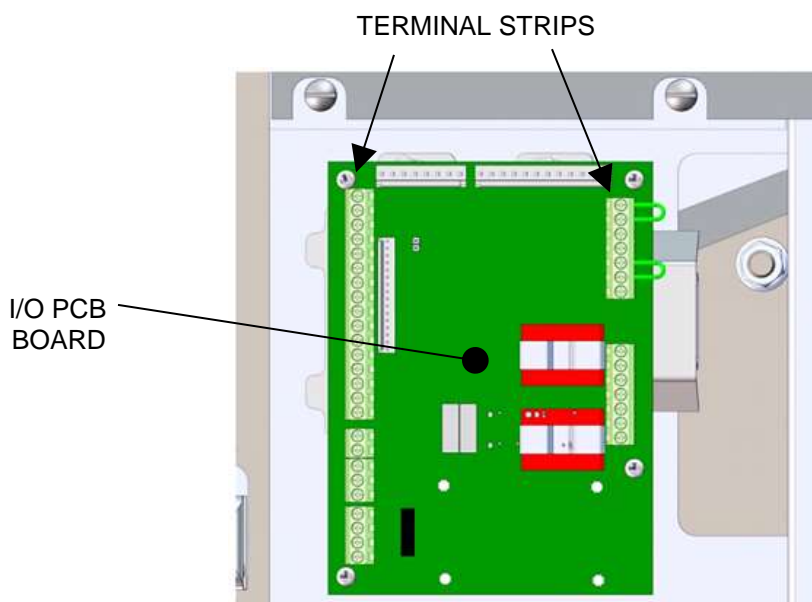
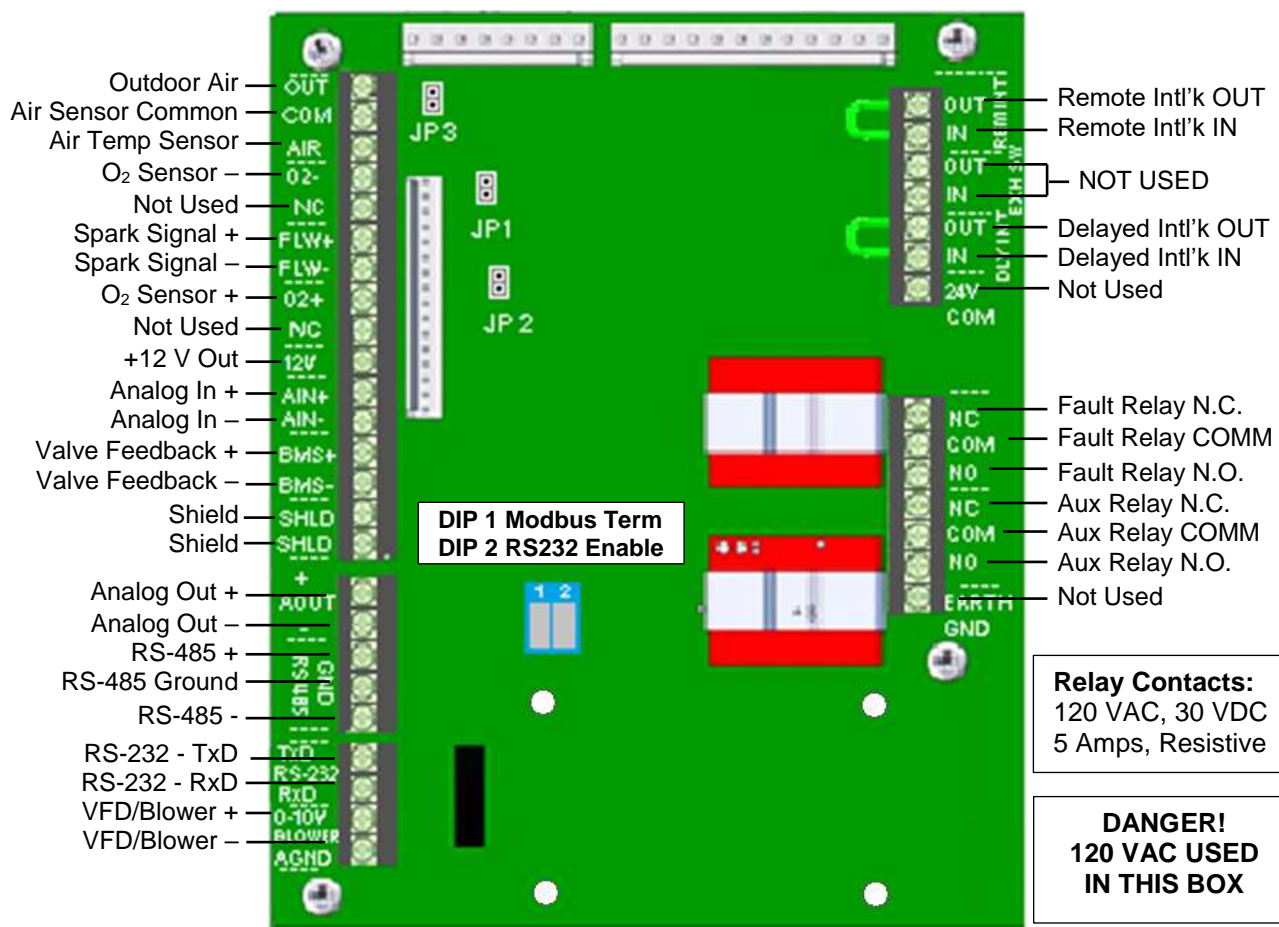

**Figure 2-13b: Input/Output (I/O) Box – Cover Removed**

**WARNING!**

DO NOT make any connections to the I/O Box terminals labeled “NOT USED”. Attempting to do so may cause equipment damage.

SECTION 2: INSTALLATION



**NOTE:**  
Refer to the image above for connections rather than the silkscreen labels shown on the PCB.

Figure 2-14: I/O Box Terminal Strips

**2.11.1 Outdoor Air & Air Sensor Common**

An outdoor temperature sensor (P/N **61047**) is required for the INDOOR/OUTDOOR RESET mode of operation. It can also be used with another mode if it is desired to use the outdoor sensor enable/disable feature, which allows the boiler to be enabled or disabled based on the outdoor air temperature.

The factory default for the outdoor sensor is DISABLED. To enable the sensor and/or select an enable/disable outdoor temperature, see Section 2.6: *CONFIGURATION Menu*, item 7, in the *Benchmark 5000 – 6000 Operation and Maintenance Guide, OMM-0124 (GF-208)*.

The outdoor sensor may be wired **up to 200 feet (61m)** from the boiler. It is connected to the **OUTDOOR AIR** and **AIR SENSOR COMMON** terminals of the I/O board (Figure 2-14). Wire the sensor using a twisted shielded pair wire from 18 to 22 AWG. There is no polarity to observe when terminating these wires. The shield is to be connected only to the terminals labeled **SHIELD** in the I/O Box PCB. The sensor end of the shield must be left free and ungrounded.

When mounting the sensor, it must be located on the North side of the building where an average outside air temperature is expected. The sensor must be shielded from direct sunlight as well as impingement by the elements. If a shield is used, it must allow for free air circulation.

### 2.11.2 AIR TEMP SENSOR

The **AIR TEMP SENSOR** terminal is used to monitor the air inlet temperature sensor (P/N 123449). This input is always enabled and is a “view only” input in the AIR TEMP setting in the *Operating* menu (see Section 2.4: *OPERATING Menu*, item 4, of the *Benchmark 5000 – 6000 Operation and Maintenance Guide*, OMM-0124 (GF-208)). A resistance chart for this sensor is provided in APPENDIX C of the same guide. This sensor is an active part of the combustion control system and must be operational for accurate air/fuel mixing control.

### 2.11.3 O<sub>2</sub> SENSOR (+ & –)

The two **O<sub>2</sub> SENSOR** terminals (+ and –) are used to connect an integrated oxygen sensor to the I/O board. The O<sub>2</sub> concentration is displayed in the *Operating* menu of the C-More Controller after a 60 second warm-up period. See Section 2.4: *OPERATING Menu*, item 13, of the *Benchmark 5000 – 6000 Operation and Maintenance Guide*, OMM-0124 (GF-208).

### 2.11.4 SPARK SIGNAL (+ & –)

Not in use on Benchmark 5000 and 6000.

### 2.11.5 ANALOG IN

The two **ANALOG IN** terminals (+ and –) are used when an external signal is used to change the setpoint (REMOTE SETPOINT mode) of the boiler.

Either a **4 to 20 mA/1 – 5 VDC** or a **0 to 20 mA/0 – 5 VDC** signal may be used to vary the setpoint or air/fuel valve position. The factory default setting is **4 to 20 mA/1 to 5 VDC**, however this may be changed to **0 to 20 mA/0 – 5 VDC** in the *Configuration* menu; see Section 2.6: *CONFIGURATION Menu*, item 6, in the *Benchmark 5000 – 6000 Operation and Maintenance Guide*, OMM-0124 (GF-208).

If voltage rather than current is selected as the drive signal, a DIP switch must be set on the PMC Board located inside the C-More Controller. Contact the AERCO factory for information on setting DIP switches.

All supplied signals must be floating (ungrounded) signals. Connections between the source and the boiler's I/O board (Figure 2-14) must be made using twisted shielded pair of 18–22 AWG wire such as Belden 9841. Polarity must be maintained and the shield must be connected only at the source end and must be left floating (not connected) at the Boiler's I/O board.

Whether using voltage or current for the drive signal, they are linearly mapped to a 40°F to 240°F (4.4°C to 116°C) setpoint or a 0% to 100% air/fuel valve position. No scaling for these signals is provided

### 2.11.6 VALVE FEEDBACK

The two **VALVE FEEDBACK** terminals (+ and –) are used when the Sequencing Isolation Valve Feedback option is selected. The Valve Feedback signal is connected to the “Valve Fdbk” terminals and is used to confirm that the valve has properly opened or closed. If the Valve Feedback signal does not match the Valve-Open or Valve-Close command for the time defined in the “Valve Fdbk timer” entry, the C-More Controller will proceed as follows:

- (a) If the valve fails with the Valve Stuck Open fault, the “Valve Stuck Open” message will be displayed and the unit will remain active.

**SECTION 2: INSTALLATION**

- (b) If the valve fails with the Valve Stuck Closed fault, the “Valve Stuck Closed” message will be displayed and the unit will shut down.

**NOTE:**

If the Valve Feedback option is used, Shorting Jumper **MUST** be inserted on JP2 on the I/O Board (see Figure 2-14, above).

**2.11.7 SHIELD (SHLD & SHLD)**

The SHIELD terminals are used to terminate any shields used on sensor wires connected to the unit. Shields must only be connected to these terminals.

**2.11.8 ANALOG OUT**

On current model Benchmark units, the default setting in the C-More Controller is Valve Position 0-10v, and behaves as follows:

- 0-10VDC **must** be selected for the voltage output used by the Controller to modulate the combustion blower via the I/O Box terminals labeled **VFD/BLOWER** (Section 2.11.11).
- If Boiler Sequencing Technology (BST) is enabled, the Analog Output terminals are used to drive the isolation valve. A 0-20 mA signal is used: 20 mA = closed, 0 mA = open.

**NOTE:**

When driving an isolation valve, shorting jumper #JP2 **MUST** be installed on the I/O Board.

On older legacy Benchmark units, the two ANALOG OUT terminals may be used to monitor Setpoint, Outlet Temperature, Valve Position 4-20 mA, Valve Position 0-10v or be set to OFF.

**2.11.9 RS485 Comm (+, GND, & -)**

The three **RS-485** communication terminals are used when the boiler plant is being controlled by an Energy Management System (EMS) or an AERCO Control System (ACS) using Modbus (RS485) communication.

**2.11.10 RS232 Comm (TxD & RxD)**

As of Firmware version 4.0 and above, these terminals are used only by factory-trained personnel to monitor onAER communications via a portable computer.

**2.11.11 VFD/Blower (0-10 & AGND)**

The two **VFD/BLOWER** terminals, 0-10 and AGND, send an analog signal to control the blower speed.

**2.11.12 Interlocks**

The unit has two interlock circuits for interfacing with Energy Management Systems and auxiliary equipment, such as pumps, louvers or other accessories. These interlocks are called the Remote Interlock and Delayed Interlock (**REMOTE INTL’K IN** and **DELAYED INTL’K IN** in Figure 2-14). Both interlocks, described below, are factory wired in the closed position using jumpers.

**NOTE:**

Both the Delayed Interlock and Remote Interlock must be in the closed position for the unit to fire.

**2.11.12.1 Remote Interlock In (OUT & IN)**

The remote interlock circuit is provided to remotely start (enable) and stop (disable) the unit if desired. The circuit is 24 VAC and comes factory pre-wired closed (jumped).

**2.11.12.2 Delayed Interlock In (OUT & IN)**

The Delayed Interlock terminals can be used in one of two ways:

- In conjunction with the optional external sequencing valve (see Section 2.15: *Sequencing Isolation Valve Installation, below*, and Section 6: *Boiler Sequencing Technology*), a component of AERCO's on-board Boiler Sequencing Technology (BST) solution. A cable of the boiler's wiring harness is connected to these terminals on all units; if BST is implemented, the other end of that cable is connected to the sequencing valve.
- If BST is *NOT* implemented, the second use is typically in conjunction with the AUXILIARY RELAY CONTACTS described in section 2.11.14, below. This interlock circuit is located in the purge section of the start string. It can be connected to the proving device (end switch, flow switch etc.) of an auxiliary piece of equipment started by the unit's auxiliary relay. If the delayed interlock is connected to a proving device that requires time to close (make), a time delay (AUX START ON DLY) that holds the start sequence of the unit long enough for a proving switch to make (close) can be programmed.

To use this option, you must disconnect the harness from the Delayed Interlock terminals and connect the proving device in its place.

Should the proving switch not prove within the programmed time frame, the unit will shut down. The AUX START ON DLY can be programmed from 0 to 120 seconds. This option is located in the *Configuration* menu (see Section 2.6: *CONFIGURATION Menu*, item 16, in the *Benchmark 5000 – 6000 Operation and Maintenance Guide, OMM-0124 (GF-208)*).

**2.11.13 Fault Relay (NC, COM, & NO)**

The fault relay is a single pole double throw (SPDT) relay having a normally open and normally closed set of relay contacts that are rated for 5 amps at 120 VAC and 5 amps at 30 VDC. The relay energizes when any fault condition occurs and remains energized until the fault is cleared and the **CLEAR** button is depressed. The fault relay connections are shown in Figure 2-14.

**2.11.14 Auxiliary Relay Contacts (NC, COM, & NO)**

Each unit is equipped with a single pole double throw (SPDT) relay that is energized when there is a demand for heat and de-energized after the demand for heat is satisfied. The relay is provided for the control of auxiliary equipment, such as pumps and louvers, or can be used as a unit status indicator (firing or not firing). Its contacts are rated for 120 VAC @ 5 amps. Refer to Figure 2-14 to locate the AUXILIARY RELAY terminals for wiring connections.

## 2.12 FLUE GAS VENT INSTALLATION

AERCO's *Benchmark Venting and Combustion Air Guide*, TAG-0022 (GF-2050) must be consulted before any flue or combustion air venting is designed or installed. Suitable, U/L approved, positive pressure, watertight vent materials **MUST** be used for safety and UL certification. Because the unit is capable of discharging low temperature exhaust gases, **the flue must be pitched back towards the unit a minimum of 1/4" per foot (21mm per m)** to avoid any condensate pooling and to allow for proper drainage.

A 12 inch (30.5 cm) Flue Vent may be used for applications with less than 20 PPM NOx. Installation with less than 9 PPM NOx require a 14 inch (35.6 cm) Flue Vent. Consult your vent manufacturer for 12 inch (30.5 cm) vent adapters. See the *Benchmark Combustion Venting and Combustion Air Guide*, TAG-0022 (GF-2050), for additional information.

While there is a positive flue pressure during operation, the combined pressure drop of vent and combustion air systems **must not exceed 140 equivalent feet (42.7m) or 1.9" W.C. (473 Pa)**. Fittings as well as pipe lengths must be calculated as part of the equivalent length. For a natural draft installation **the draft must not exceed -0.25" W.C. (-62 Pa)**. These factors must be planned into the vent installation. If the maximum allowable equivalent lengths of piping are exceeded, the unit will not operate properly or reliably.

### 2.12.1 MASSACHUSETTS INSTALLATIONS

The following companies provide vent systems which conform to all applicable requirements for installations within the Commonwealth of Massachusetts:

<p><b>Selkirk Corporation - Heatfab Division</b>                  130 Industrial Blvd.                  Turners Falls, MA 01376                  Phone: 1-800-772-0739  <a href="http://www.heatfab.com">www.heatfab.com</a></p>	<p><b>Watertown Supply</b>                  33 Grove St.                  Watertown, MA 02472                  Phone: (617) 924-2840  <a href="http://www.watertownsupply.com">www.watertownsupply.com</a></p>
<p><b>Glover Sheet Metal, Inc.</b>                  44 Riverdale Ave.                  Newton, MA 02485                  Phone: (617) 527-8178  <a href="http://www.gloversheetmetal.com">www.gloversheetmetal.com</a></p>	<p><b>Emerson Swan Co</b>                  Engineering Products Department                  300 Pond St.                  Randolph, MA 02368                  Phone 781-986-2555                  Fax 781-986-2027  <a href="http://www.emersonswan.com">www.emersonswan.com</a></p>

## 2.13 COMBUSTION AIR

The *Benchmark Venting and Combustion Air Guide*, TAG-0022 (GF-2050) MUST be consulted before any flue or inlet air venting is designed or installed. Air supply is a direct requirement of ANSI 223.1, NFPA-54, CSA B149.1 and local codes. These codes should be consulted before a permanent design is determined.

The combustion air must be free of chlorine, halogenated hydrocarbons or other chemicals that can become hazardous when used in gas-fired equipment. Common sources of these compounds are swimming pools, degreasing compounds, plastic processing, and refrigerants. Whenever the environment contains these types of chemicals, combustion air MUST be supplied from a clean area outdoors for the protection and longevity of the equipment and warranty validation.

If combustion air is supplied directly to the unit(s) through air duct(s), see section 2.13.1 below.

If combustion air is not supplied through air ducts, it must be supplied to the unit(s) through two permanent openings. These two openings must have a free area of **not less than one square inch (6.5 cm<sup>2</sup>) for each 4000 BTUs (1.17 kW) input for each unit**, or **1,500 square inches (0.96 m<sup>2</sup>)** of free area for the BMK 6000, or **1,250 square inches (0.81 m<sup>2</sup>)** of free area for the BMK 5000. The free area must take into account restrictions such as louvers and bird screens. For Canada installations, refer to the requirements specified in CSA B149.1-10, sections 8.4.1 and 8.4.3.

### NOTE:

The source of internal combustion air must be positive or neutral in pressure. Negative pressure inside a boiler room may have an adverse effect on combustion equipment.

### 2.13.1 DUCTED COMBUSTION AIR

For ducted combustion air installations, the air ductwork must be attached directly to the air inlet connection on the sheet metal enclosure. Consult the *Benchmark Venting and Combustion Air Guide*, TAG-0022 (GF-2050) when designing combustion air ducting.

In a ducted combustion air application, the combustion air ducting pressure losses must be taken into account when calculating the total maximum allowable venting run. When using the unit in a ducted combustion air configuration, each unit must have a **minimum 14 inch (35.56 cm)** diameter connection at the unit.

## 2.14 BENCHMARK PUMP RELAY

All Benchmark units ship with a pump relay (P/N **69102-3**) as standard equipment. The pump relay allows the user to turn a pump on/off and open/close a motorized valve as the boiler cycles on and off on demand. The Pump Delay Timer feature allows the user to keep the pump running and keep the motorized valve open for up to 30 minutes after the boiler has shut down and the demand is satisfied. See Figures 2-16 and 2-17 for wiring details.

The pump relay is attached to the outside of the power box, as shown below. Boilers equipped with the pump relay have a label on the power box cover adjacent to the relay.



SECTION 2: INSTALLATION

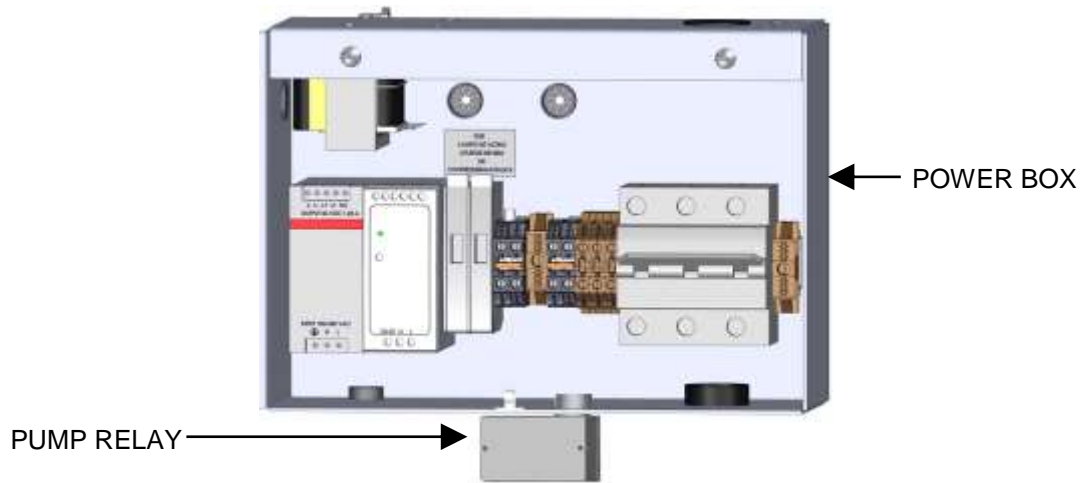

**Figure 2-15: Pump Relay Location**

The Benchmark pump relay (SPDT) contact is rated for:

- 10 A Resistive @ 277 VAC/28 VDC
- 1/3 HP N/O @ 120/240 VAC
- 1/6 HP N/C @ 120/240 VAC
- 480 VAC Pilot Duty @ 240-277 VAC Pilot Duty

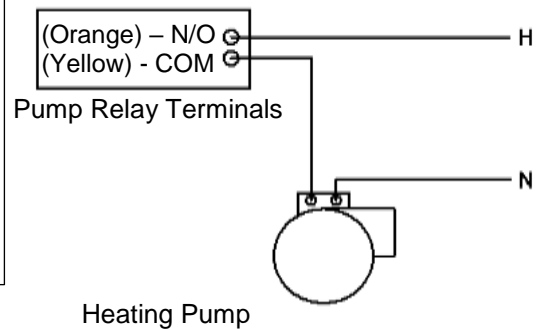

**Figure 2-16: Schematic – System Pump Start using Boiler Pump Relay**

If pump/valve load exceeds the above contact ratings, use a separate contact relay, as shown in Figure 2-17.

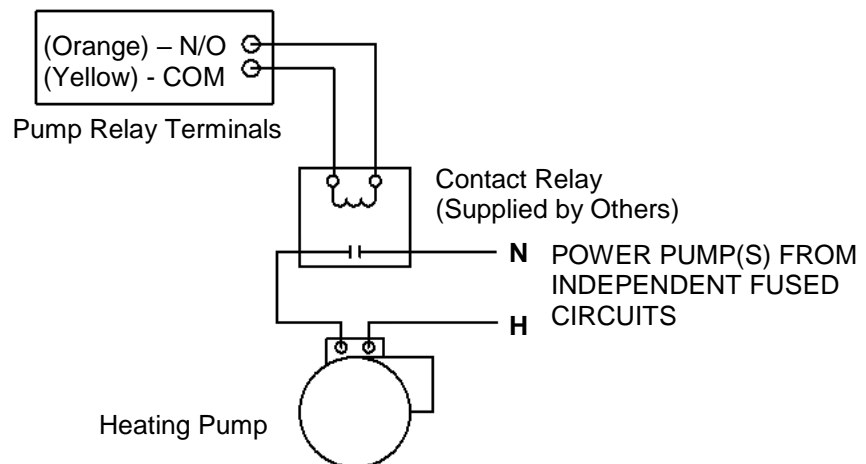

**Figure 2-17: Schematic – System Pump Start using a Separate Contact Relay**

## 2.15 SEQUENCING ISOLATION VALVE INSTALLATION

All Benchmark units are pre-wired with a connection for an optional motorized external sequencing isolation valve (P/N **92084-TAB**). This valve is an integral component of AERCO's on-board Boiler Sequencing Technology (BST) solution. BST allows sites with multiple boilers to have one boiler, acting as a "Manager" to manage the other boilers at the site, designated as "Clients" in such a way that the efficiency of the entire boiler array is maximized.

When operated with the BST system, the Manager controls its own isolation valve and sends signals to the Client units to open or close their isolation valves. After the boiler load is satisfied, the isolation valve remains open for a programmed interval (default = 1 minute) then closes. When the system load is satisfied, the BST system will open the isolation valves for all of the boilers.

The implementation of BST, and the installation and use of this valve is optional. However, **when BST is implemented, use of this valve is strongly recommended.**

The boiler is pre-wired to accept the sequencing isolation valve. Installation consists of installing the sequencing isolation valve in the hot water outlet pipe, and then connecting it to the pre-wired connector on the shell harness, as described below.

### NOTE:

When the Sequencing Isolation Valve is used, the AUX START ON DLY in the *Configuration* menu must be set to 120 seconds (see Section 2.6: *CONFIGURATION Menu*, item 16, in the *Benchmark 5000 – 6000 Operation and Maintenance Guide, OMM-0124 (GF-208)*). The Sequencing Isolation Valve control is only available when BST is enabled. Refer to section 2.11.12.2 (wiring) and Section 6: *Boiler Sequencing Technology* in this guide, and Section 2.6: *CONFIGURATION Menu* in the *Benchmark 5000 – 6000 Operation and Maintenance Guide, OMM-0124 (GF-208)*.

### Sequencing Isolation Valve Installation Instructions

1. Install the sequencing isolation valve in the boiler's hot water outlet pipe (Figure 2-18).

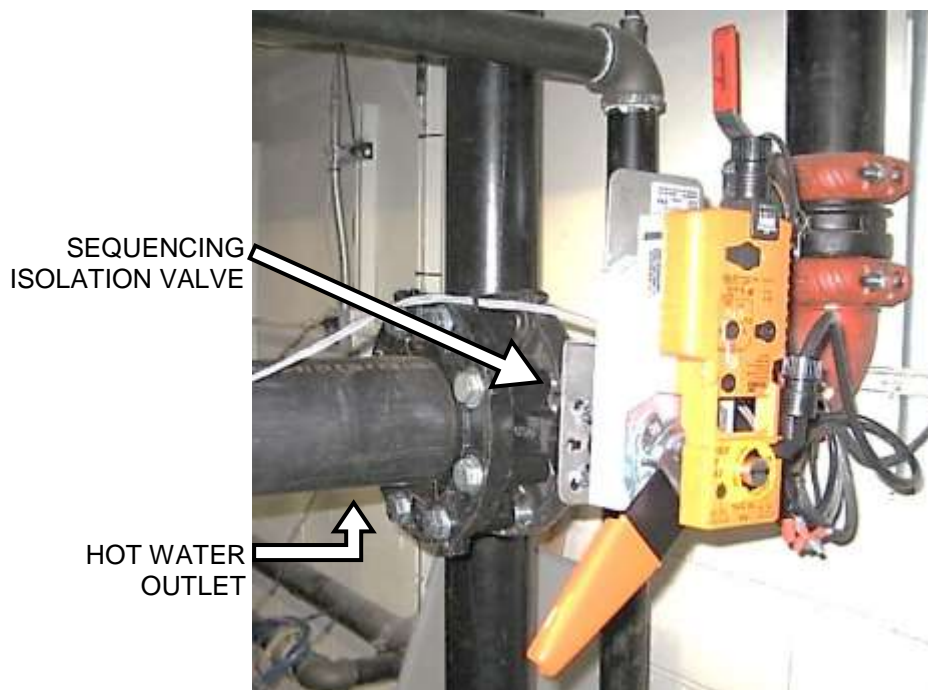

**Figure 2-18: Sequencing Isolation Valve Installed**

2. Find the unused black cable, coiled inside the unit's enclosure. One end is connected to the DELAYED INTERLOCK IN terminals in the I/O board, while the other end contains a Molex connector with a cap containing a jumper wire inserted in it (this jumper wire allows units that do not have a sequencing isolation valve to operate normally).
3. Remove the cap (with jumper wire attached) from the Molex connector and dispose of it.



**Figure 2-19: Sequencing Isolation Valve Molex Connector and Jumper Wire**

4. Plug the Molex connector into the sequencing isolation valve's connector.

(This page intentionally blank)

## SECTION 3: START SEQUENCE

### 3.1 INTRODUCTION

The information in this section provides a guide to starting the Benchmark Boiler using the C-More Controller, which is mounted on the front of the unit. It is imperative that the initial startup of this unit be performed by factory trained personnel. Operation prior to initial startup by factory trained personnel may void the equipment warranty. In addition, the following WARNINGS and CAUTIONS must be observed at all times.

#### WARNING!

- Electrical voltages in this system include **120, 208, 460, 575** and **24** volts AC. It must be serviced only by factory certified service technicians.
- **Do not attempt to dry fire the unit.** Starting the unit without a full water level can seriously damage the unit and may result in injury to personnel or property damage. This situation will void any warranty.

#### CAUTION!

All of the installation procedures in Section 2 must be completed before attempting to start the unit.

### 3.2 START SEQUENCE

When the C-More Controller's ON/OFF switch is set to the **ON** position, it checks all pre-purge safety switches to ensure they are closed. These switches include:

- **Safety Shut-Off Valve (SSOV) Proof of Closure (POC) switch**
- **Low Water Level switch**
- **High Water Temperature switch**
- **High Gas Pressure switch**
- **Low Gas Pressure switch**

#### NOTE:

The **Blocked Inlet** and downstream **Blower Proof** switches are *not* checked prior to starting the pre-purge.

If all of the above switches are closed, the READY light above the ON/OFF switch will light and the unit will be in the STANDBY mode.

#### NOTE:

If any of the Pre-Purge safety device switches are open, the appropriate fault message will be displayed. Also, the appropriate messages will be displayed throughout the start sequence, if the required conditions are not observed.

**SECTION 3: START SEQUENCE**

When there is a demand for heat, the following events will occur:

**Start Sequence**

1. The DEMAND LED status indicator will light.
2. The unit checks to ensure that the Proof of Closure (POC) switch in the downstream Safety Shut-Off Valve (SSOV) is closed. See Figure 3-1 for SSOV location.

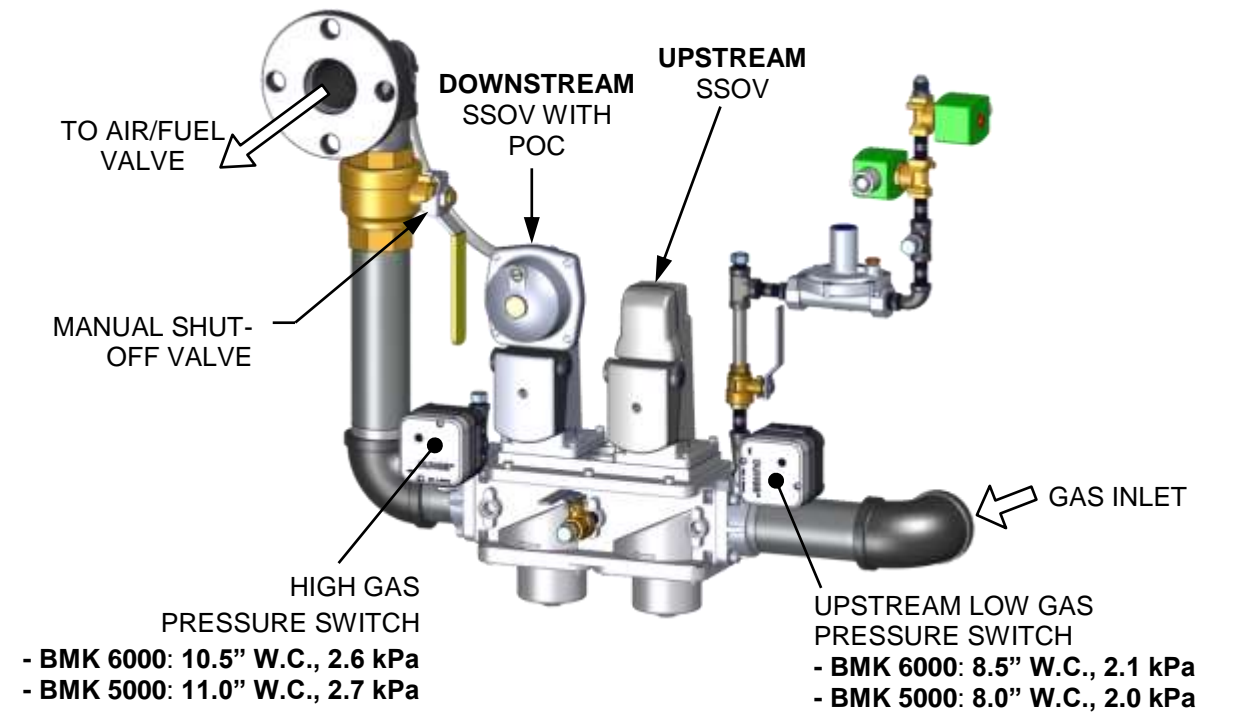

**Figure 3-1: SSOV Location**

3. With all required safety device switches closed, a purge cycle will be initiated and the following events will occur:
  - a. The Blower relay energizes and turns on the blower.
  - b. The Air/Fuel Valve rotates to the full-open purge position and closes purge position switch. The dial on the Air/Fuel Valve (Figure 3-2) will read 100 to indicate that it is full-open (100%).
  - c. The VALVE POSITION bargraph will show 100%.

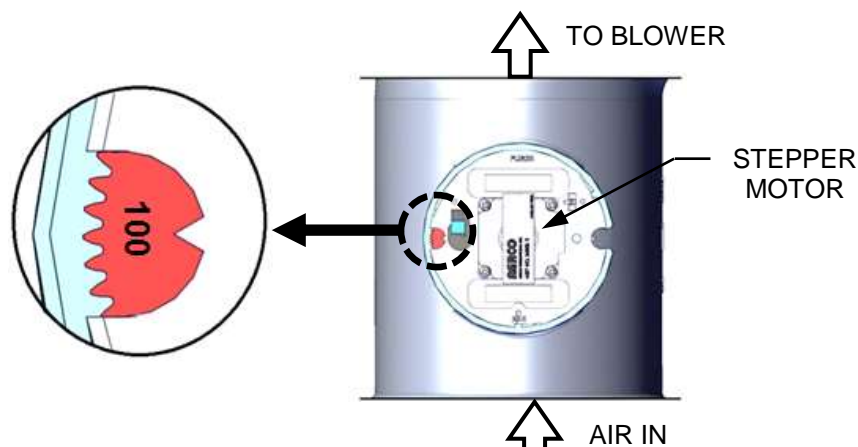

**Figure 3-2: Air/Fuel Valve In Purge Position**

### Start Sequence

4. Next, the blower proof switch on the Air/Fuel Valve (Figure 3-3) closes. The display will show *PURGING* and indicate the elapsed time of the purge cycle in seconds.

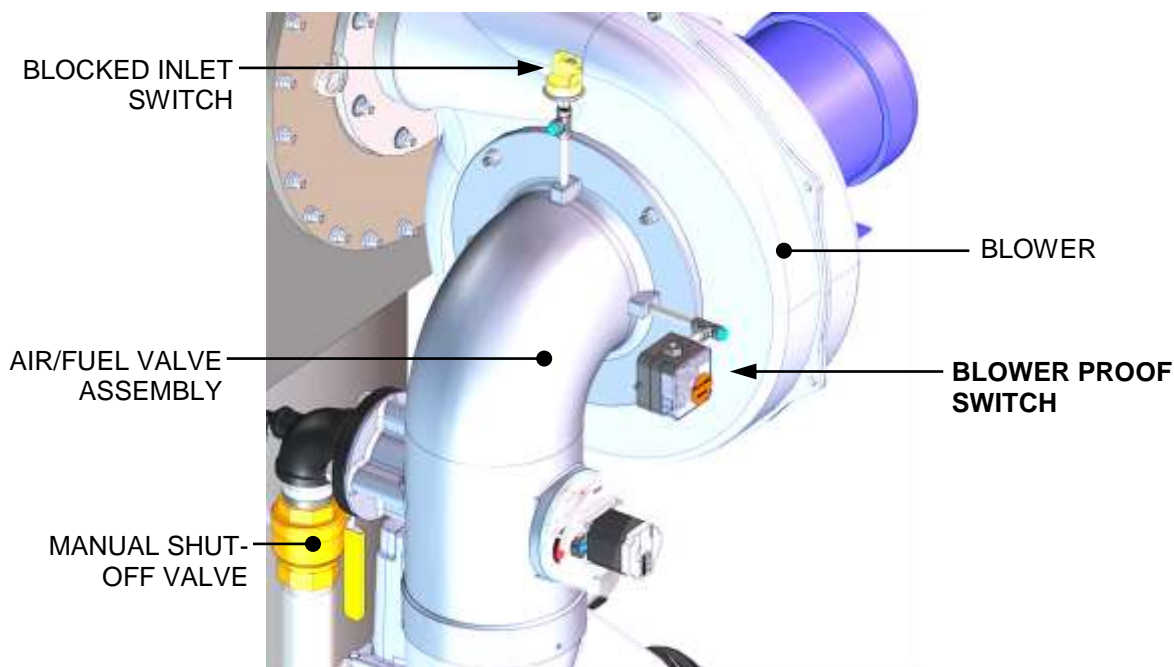

**Figure 3-3: Blower Proof Switch**

5. Upon completion of the purge cycle, the C-More Controller initiates an ignition cycle and the following events occur:
  - a. The Air/Fuel Valve rotates to the low-fire (Ignition Position) position and closes the ignition switch. The dial on the Air/Fuel Valve will read between 45 and 50 (see Figure 3-4) to indicate that the valve is in the low-fire position.
  - b. Power is supplied to the Spark Igniter.
  - c. Power is supplied to the Pilot Gas Solenoid.
  - d. The Pilot Flame Detectors prove the Pilot Flame and the red LED stops blinking and changes to steady ON.
  - e. Ignition relay 1 (R1) closes allowing the main Burner ignition sequence to start.

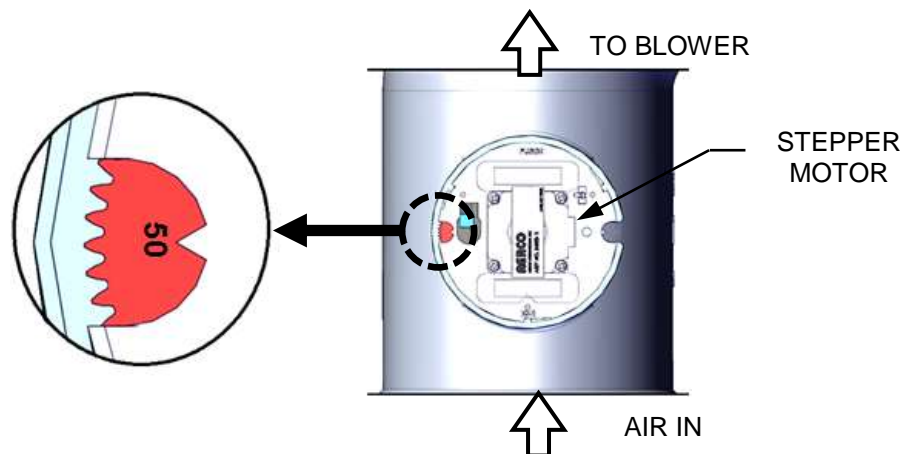

**Figure 3-4: Air/Fuel Valve in Ignition Position**

**Start Sequence**

6. Once the spark cleaning period is finished and ignition relay 1 (R1) closes, power is supplied to the SSOVs and the following events occur in 7 seconds:
  - a. The SSOVs open allowing gas to flow into the Air/Fuel Valve.
  - b. The Main Burner ignites.
  - c. Main Burner flame is sensed by the C-More Controller.
  - d. The C-More Controller turns off power to the ignition transformer and Pilot solenoid valve.
  - e. Relay 2 (R2) remains energized via the POC Normally Open (N.O.) contact of the upstream SSOV actuator.
7. A maximum of 14 seconds are allowed for the entire ignition sequence, from applying power to the ignition transformer through actual Burner flame establishment. The igniter relay will be turned off one second after flame is detected.
8. After 2 seconds of continuous flame, *FLAME PROVEN* will be displayed and the flame strength will be indicated. After 5 seconds, the current date and time will be displayed in place of the flame strength.
9. With the unit firing properly, it will be controlled by the temperature control circuitry. The boiler's *VALVE POSITION* will be continuously displayed on the C-More Controller's front panel bargraph.
10. Once the demand for heat has been satisfied, the C-More Controller will turn off the SSOV gas valves, the blower relay will be deactivated, the Air/Fuel Valve will be closed and *STANDBY* will be displayed.



SECTION 3: START SEQUENCE

BMK 5000 & 6000 Function Timing Chart For Proved Pilot Control System						
Component	Operating State					
	Standby	C-More Pre-purge		PFEF	MFEP	Run
		T = 0	T = 30	T = 37	T = 44	
				PFEF	MFEP	
C-More Controller						
Scanner Power						
Ignition Power						
SSOV Power						
Pilot Valve Closed						
Pilot Valve Open						
Ignition Transformer Off						
Ignition Transformer On						
UV Scanner Powered						
UV Scanner "Ignored"						
UV Scanner In Use						
Relay 1 Coil						
Relay 1 C-NC						
Relay 1 C-NO						
Relay 2 Coil Power from R1						
Relay 2 Coil Power from SKP 15 POC						
Relay 2 C-NC						
Relay 2 C-NO						
SKP15 Power from R1 Contacts						
SKP15 Power from R2 contact and POC C-NO						
SKP15 Proof of Closure C-NC						
SKP15 Proof of Closure C-NO						
SKP25						
Power through R1						
Power through R2 and AUX						
Proof of Closure C-NC						
Proof of Closure C-NO						

### 3.3 START/STOP LEVELS

The start and stop levels are the Air/Fuel Valve positions (% open) that start and stop the unit, based on load. These levels are Factory preset as follows:

BMK 5000/6000 Start/Stop Levels for Natural Gas	
Start Level:	24%
Stop Level:	18%

Normally, these settings should not require adjustment.

Note that the energy input of the boiler is not linearly related to the Air/Fuel Valve position.

### 3.4 START/STOP LEVELS – AIR/FUEL & ENERGY INPUT

The Tables in this section show the relationship between the energy input and Air/Fuel Valve position for the BMK models covered in this document.

#### 3.4.1 Benchmark 5000 Air/Fuel Valve Position and Energy Input

BMK 5000 Air/Fuel Valve Position and Energy Input		
Air Fuel Valve Position (% Full Open)	Boiler Energy Input	
	BTU/Hr	% of Full Capacity
0%	0	0%
10%	0	0%
18% (Stop Level)	400,000 (117 kW)	8%
30%	997,217 (292 kW)	20%
40%	1,667,848 (489 kW)	33%
50%	1,992,380 (584 kW)	40%
60%	2,486,881 (729 kW)	50%
70%	2,981,381 (874 kW)	60%
80%	3,780,230 (1108 kW)	76%
90%	4,375,500 (1282 kW)	88%
100%	5,000,000 (1465 kW)	100%

BMK 5000 Gas Pressure De-Rating Chart				
Applies to all models except Low Gas Pressure (LGP) models				
Gas Pressure @ SSOV in inches W.C. (kPa)		Energy Input in BTU/hr	Oxygen (%O <sub>2</sub> )	DeRating (% Full Fire)
Inlet	Outlet			
56" (13.9 kPa)	6.8" (1.70 kPa)	5,000,000 (1465 kW)	5.7	0%
14" (3.49 kPa)	6.8" (1.70 kPa)	5,000,000 (1465 kW)	5.7	0%
10" (3.23 kPa)	6.8" (1.70 kPa)	5,000,000 (1465 kW)	5.7	0%

### 3.4.2 Benchmark 6000 Air/Fuel Valve Position and Energy Input

BMK 6000 Air/Fuel Valve Position and Energy Input		
Air Fuel Valve Position (% Full Open)	Boiler Energy Input	
	BTU/Hr	% of Full Capacity
0%	0	0%
10%	0	0%
18% (Stop Level)	385,000 (113 kW)	6%
20%	400,000 (117 kW)	7%
30%	540,000 (158 kW)	9%
40%	770,000 (226 kW)	13%
50%	1,160,000 (340 kW)	19%
60%	1,650,000 (484 kW)	28%
70%	2,386,000 (699 kW)	40%
80%	3,515,000 (1030 kW)	59%
90%	4,650,000 (1362 kW)	78%

### BMK 6000 Gas Pressure De-Rating Chart

Applies to all models except Low Gas Pressure (LGP) models

Gas Pressure @ SSOV in inches W.C. (kPa)		Energy Input in BTU/hr	Oxygen (%O <sub>2</sub> )	DeRating (% Full Fire)
Inlet	Outlet			
56" (13.9 kPa)	8" (1.99 kPa)	6,000,000 (1758 kW)	5.40	0%
14" (3.49 kPa)	8" (1.99 kPa)	6,000,000 (1758 kW)	5.40	0%
13" (3.23 kPa)	8" (1.99 kPa)	5,860,000 (1717 kW)	5.45	2%

### 3.5 Boiler Energy Input Charts

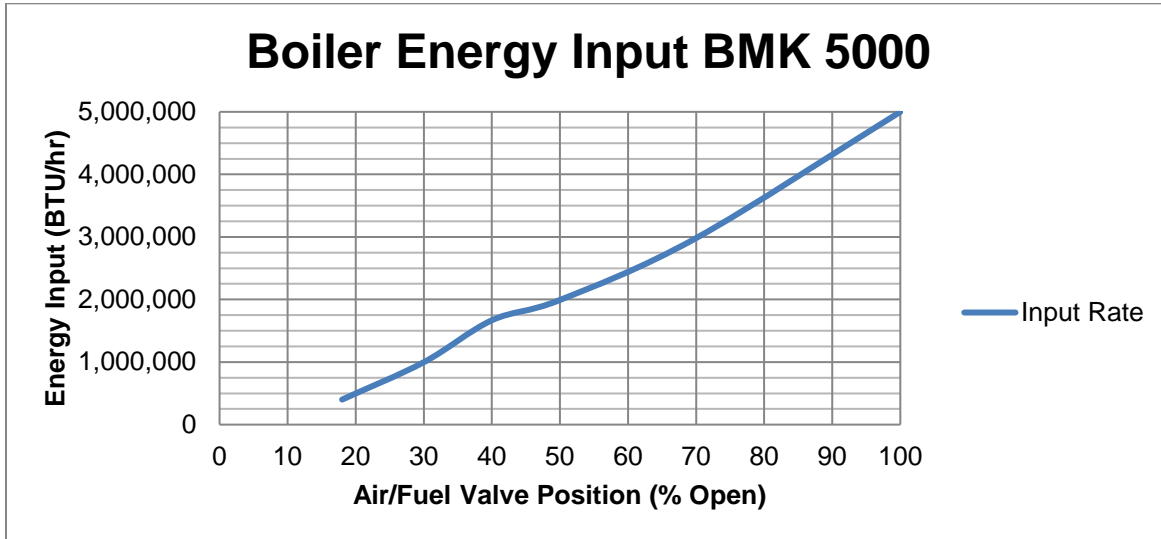

**Figure 3-5: Relationship Between BMK 5000 Air/Fuel Valve Position and Energy Input**

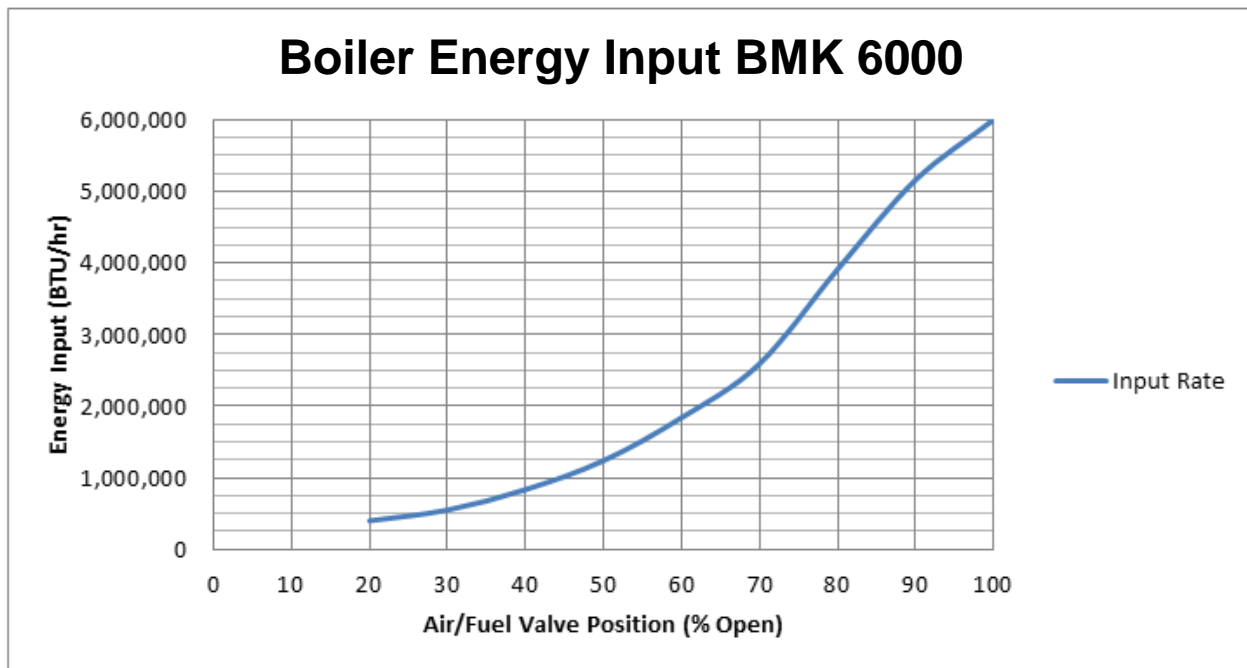

**Figure 3-6: Relationship Between BMK 6000 Air/Fuel Valve Position and Energy Input**

SECTION 3: START SEQUENCE

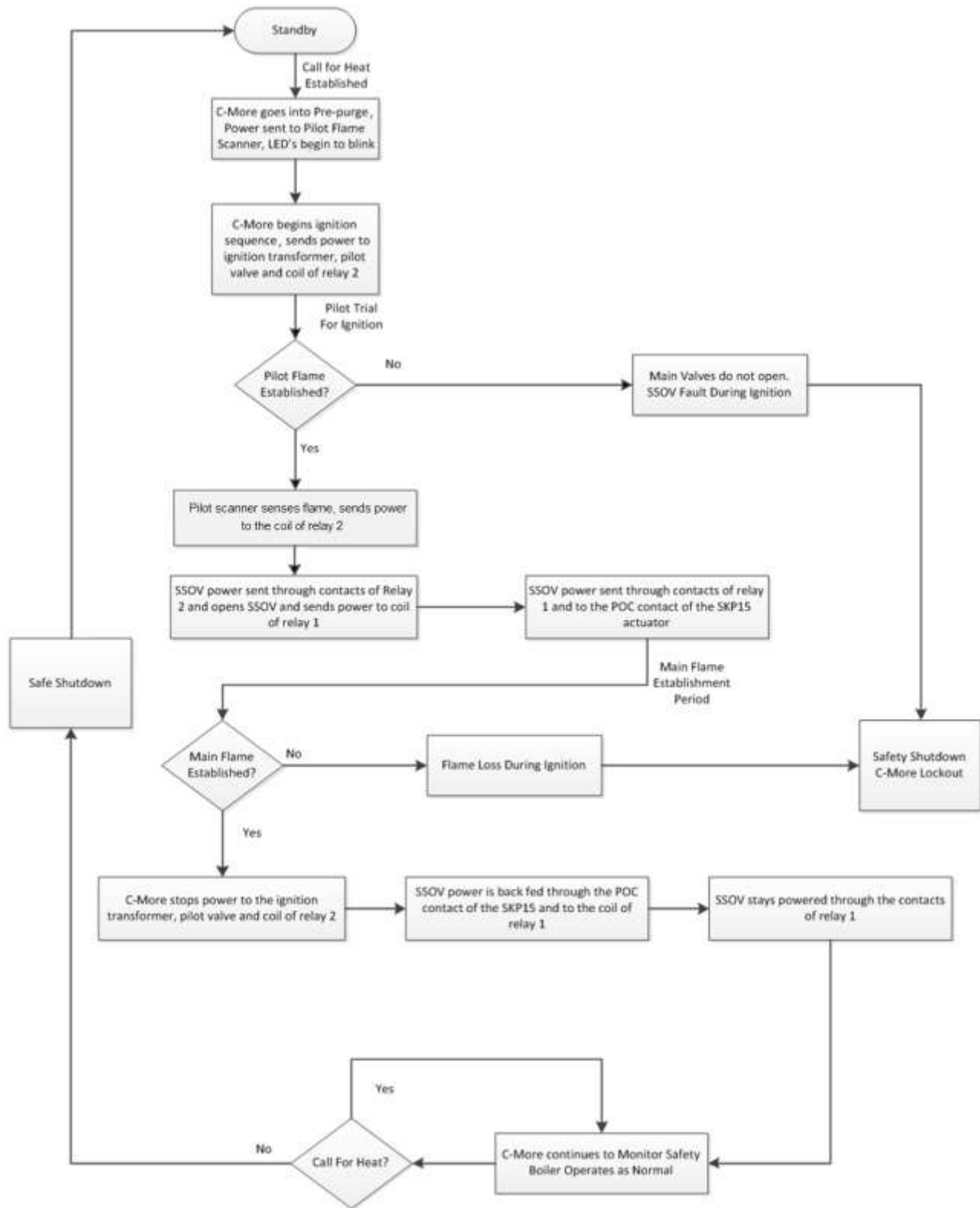

Figure 3-7: Burner Ignition Sequence Flow Chart

(This page intentionally blank)

## SECTION 4: INITIAL START-UP

### 4.1 INITIAL START-UP REQUIREMENTS

The requirements for the initial start-up of the Benchmark boiler consists of the following:

- Complete the installation (Section 2: *Installation*, above)
- Set proper controls and limits (Section 2: *Operation of the of the Benchmark 5000 – 6000 Operation and Maintenance Guide, OMM-0124 (GF-208)*)
- Perform combustion calibration (Section 4.4: *Combustion Calibration*, below)
- Test safety devices (Section 5: *Safety Device Testing*, below)

All applicable installation procedures in Section 2: *Installation* must be fully completed prior to performing the initial start-up of the unit. The initial start-up must be successfully completed prior to putting the unit into service. Starting a unit without the proper piping, venting, or electrical systems can be dangerous and may void the product warranty. The following start-up instructions should be followed precisely in order to operate the unit safely and at a high thermal efficiency, with low flue gas emissions.

Initial unit start-up must be performed ONLY by AERCO factory trained start-up and service personnel. After performing the start-up procedures in this section, below, you must perform the procedures in Section 5: *Safety Device Testing*, below, before putting the unit into service.

An AERCO Gas Fired Startup Sheet, included with each Benchmark unit, must be completed for each unit for warranty validation and a copy must be returned promptly to AERCO via e-mail at: [STARTUP@AERCO.COM](mailto:STARTUP@AERCO.COM).

#### WARNING!

DO NOT ATTEMPT TO DRY FIRE THE UNIT. Starting the unit without a full water level can seriously damage the unit and may result in injury to personnel or property damage. This situation will void any warranty.

#### NOTE

All applicable installation procedures in Section 2: *Installation* must be completed before attempting to start the unit.

## 4.2 TOOLS & INSTRUMENTS FOR COMBUSTION CALIBRATION

To properly perform combustion calibration, the proper instruments and tools must be used and correctly attached to the unit. The following sections outline the necessary tools and instrumentation as well as their installation.

### 4.2.1 Required Tools & Instrumentation

The following tools and instrumentation are necessary to perform combustion calibration of the unit:

- Digital Combustion Analyzer: Oxygen accuracy to  $\pm 0.4\%$ ; Carbon Monoxide (CO) and Nitrogen Oxide (NO<sub>x</sub>) resolution to 1 PPM.
- 0 to 16" W.C. (0 to 4.0 kPa) manometer or equivalent gauge and plastic tubing.
- OPTIONAL: 1/4 inch NPT-to-barbed fittings for use with gas supply manometer or gauge.
- Small and large flat blade screwdrivers.
- Tube of silicone adhesive

### 4.2.2 Installing Gas Supply Manometer

The gas supply manometer (or gauge) is used to monitor the gas pressure on the downstream side of the SSOV during the Combustion Calibration procedures described in Section 4.5.1: *Natural Gas Combustion Calibration* or Section 4.5.2: *Propane Gas Combustion Calibration*.

The gas supply manometer is installed at the upstream and/or downstream location shown in Figure 4-1.

The gas supply manometer is installed at the downstream location shown in Figure 4-1.

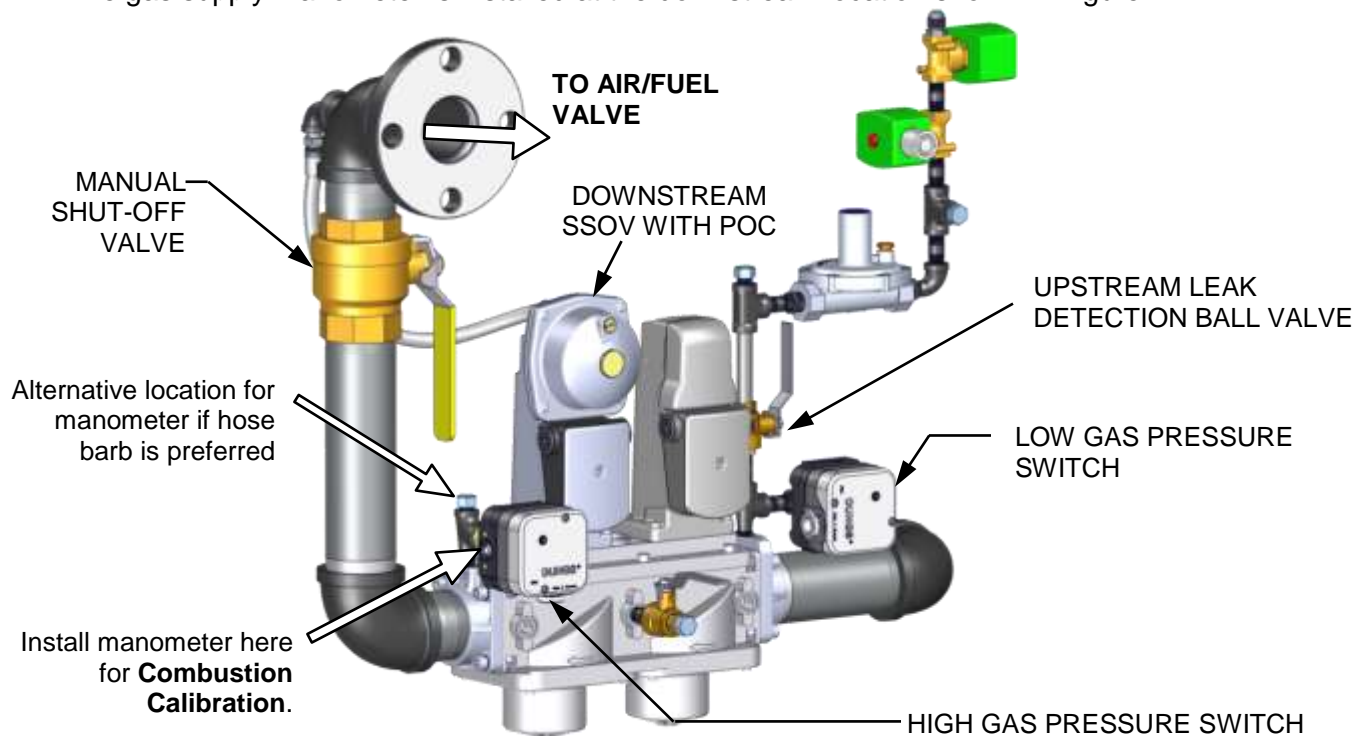

**Figure 4-1: Port Location for Combustion Calibration**



**SECTION 4: INITIAL START-UP**

To monitor the gas pressure on the downstream side of the SSOV during Combustion Calibration (in Section 4.5.1 and/or 4.5.2, below), install the 16" W.C. (4.0 kPa) manometer(s) as described in the following steps:

**Gas Supply Manometer Installation Instructions**

1. Turn off the main gas supply upstream of the unit.
2. Remove the front panel from the boiler to access the gas train components.
3. To monitor the gas pressure on the downstream side of the SSOV during Combustion Calibration (section 4.5.1 and/or 4.5.2, below), locate the port on the side of the High Gas Pressure switch, as shown in Figure 4-1, and loosen the screw inside a few turns to open it. *Do not remove this screw completely.* Alternatively, you can remove the 1/4 inch plug shown in Figure 4-1, above, and install a hose barb fitting in that location.
4. Attach one end of the plastic tubing to the port or barbed fitting and the other end to the 0 to 16 inch W.C. (0 to 4.0 kPa) manometer.

**4.2.3 Accessing the Analyzer Probe Port**

The unit contains a 1/4" NPT port on the side of the exhaust manifold as shown in Figure 4-2. Prepare the port for the combustion calibration as shown below.

**Analyzer Probe Port Access Instructions**

1. Refer to Figure 4-2 and remove one of the four 1/4" NPT plugs (P/N 9-22) from the desired location on the exhaust manifold. There are four 1/4" NPT ports, two in the front of the exhaust manifold and two in the rear, on the left and right sides.
2. If necessary, adjust the stop on the combustion analyzer probe; if using the front port, the probe should be inserted as far as possible. **DO NOT** install the probe at this time.

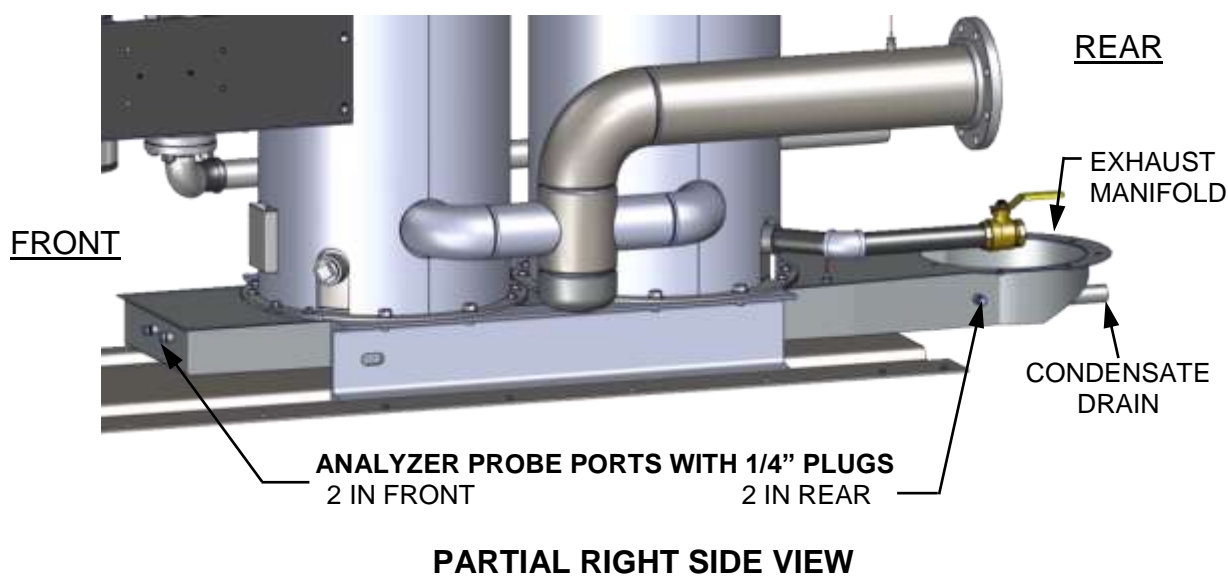

**Figure 4-2: Analyzer Probe Hole Locations**

### 4.3 Benchmark 5000 & 6000 PILOT IGNITION

Benchmark 5000 and 6000 boilers are equipped with an interrupted pilot ignition system. The pilot is ignited by a spark discharge within the Pilot Burner inside the combustion chamber. The input of the Pilot flame is approximately **18,000 BTU/hr. (5.3 kW)**. The Pilot Burner flame will stay ignited until the main Burner flame has stabilized and **FLAME PROVEN** appears in the C-More Controller's display.

A Pilot gas supply regulator **reduces** the supply pressure as follows:

- On standard pressure models, it reduces line pressure to **4.9" W.C. (1.2 kPa)**.
- On Low Gas Pressure models, it reduces line pressure to **2.0" W.C. (0.5 kPa)**.

The Pilot Burner should be inspected at the beginning of each heating season, or every 6 months for continuous operation. It is constructed of high quality, heat resistant stainless steel, however some darkening of the metal is expected. No adjustment of the Pilot should be required, however the gas pressure downstream of the regulator should be checked if an ignition issue is encountered. Refer to Figure 4-1 for test port location.

The Pilot flame is proven by two Pilot Flame Detectors, located above and below the Pilot. The two Pilot Flame Detectors are optical sensors inserted into tubes with quartz windows; they observe the Pilot through holes in the refractory. They have a red LED which changes from flashing to steady-ON when they encounter the flicker of a flame that meets or exceeds the internal sensing threshold. (Only one of the two detectors needs to sense the pilot flame throughout the ignition period). The holes in the refractory should be checked annually to ensure that the optical path to the Pilot Burner is clear.

**NOTE:**

The pilot flame detectors switch the signal to neutral when the flame is proven.

### 4.4 FUEL TYPES and COMBUSTION CALIBRATION

Benchmark 5000 and 6000 models may be ordered from the factory to use natural gas only, propane only, or in a dual fuel version that can be configured on site to switch between natural gas or propane gas.

Both fuel types require different combustion calibration values, and so care should be taken to ensure the appropriate instructions are used for the fuel being used. Combustion calibration instructions for natural gas are presented in Section 4.5.1 and for propane in Section 4.5.2.

Instructions for switching between fuel types in dual fuel models is presented in section 4.7.

**CAUTION!**

Ensure the appropriate combustion calibration instructions are used for the fuel being used in the boiler.

## 4.5 COMBUSTION CALIBRATION

The Benchmark boiler was combustion calibrated with either standard combustion (NO<sub>x</sub> emissions of **<20 ppm**) or Ultra-Low NO<sub>x</sub> (NO<sub>x</sub> **<9 ppm**) at the factory prior to shipping, depending on which was ordered.

However, recalibration as part of initial start-up is necessary due to changes in the local altitude, gas BTU content, gas supply piping and supply regulators. Combustion Calibration Test Data sheets are shipped with each unit. These sheets must be filled out and returned to AERCO for proper Warranty Validation.

**It is important to perform the procedure below, as it will keep readjustments to a minimum and provide optimum performance.**

- For units running on NATURAL GAS, standard & Ultra-Low NO<sub>x</sub>, complete Section 4.5.1
- For units running on PROPANE gas complete Section 4.5.2

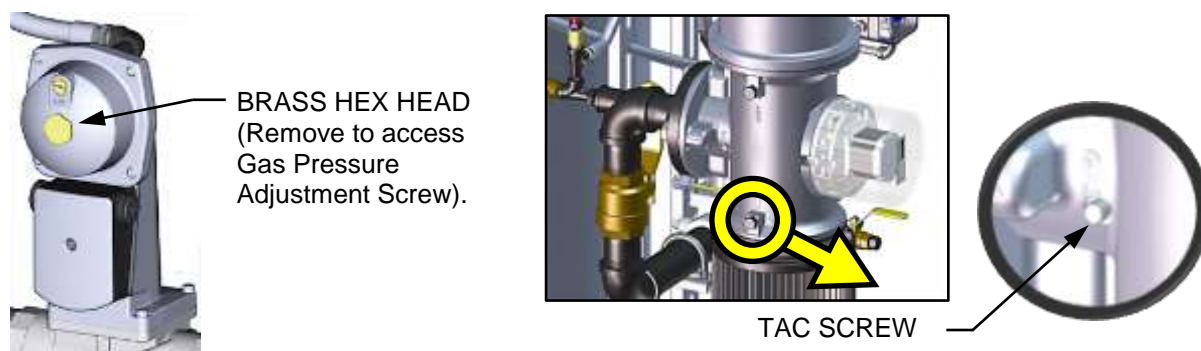

**Figure 4-3: Gas Pressure Adjustment Screw and TAC Screw Location**

### 4.5.1 NATURAL GAS Combustion Calibration

The instructions below apply only to units running on **NATURAL GAS**. Instructions for doing combustion calibration on a unit running PROPANE appear in the next section, 4.5.2.

#### **NATURAL GAS Combustion Calibration Instructions**

1. Open the water supply and return valves to the unit and ensure that the system pumps are running.
2. Open the NATURAL GAS supply valve to the unit and then slowly open the Pilot gas valve.
3. Set the C-More Controller's ON/OFF switch to the OFF position.
4. Turn external AC power to the unit ON. The display will show a description of the unit and then the time and date.
5. Press the MENU key on the front panel of the C-More and access the *Setup* menu, enter the password 6817 and then press the ENTER key.
6. Set the unit to the MANUAL mode by pressing the AUTO/MAN key. A flashing *Manual Valve Position* message will be displayed with the present position in % and the MANUAL LED will light.
7. Adjust the air/fuel valve position to 0% by pressing the ▼ arrow key and then pressing ENTER.

**NATURAL GAS Combustion Calibration Instructions**

8. Ensure that the leak detection ball valve downstream of the SSOV is open and the manometer is attached and functioning properly.
9. Set the ON/OFF switch to the ON position.
10. Press the MENU key on the front panel of the C-More until *COMBUSTION CAL MENU* appears on the display.
11. Press the Up ▲ arrow key until *SET Stdby V Out (Standby Voltage)* setting appears. Verify that it is set to 2.0 V (the default). AERCO recommends it be kept at 2.0 volts to prevent flue gas recirculation. Individually vented units in positive pressure boiler rooms may set *SET Stdby V Out* to 0 volts.
12. Press the Down ▼ arrow key until *SET Valve Position* appears, then press CHANGE.
13. Use the Up ▲ arrow key to change the valve position to 50%. The unit should begin its start sequence and fire.
14. Next, verify that the manifold gas pressure, downstream of the SSOV, is within the range in Table 4-1, for the model you are calibrating. If gas pressure adjustment is required, remove the brass hex nut on the SSOV actuator to access the gas pressure adjustment screw (Figure 4-3). Make gas pressure adjustments using a flat-tip screwdriver to obtain a gas pressure in the range specified in Table 4-1.

**TABLE 4-1: NATURAL GAS Manifold Gas Pressure Range @ 100% Fire Rate**

Model	Single-Fuel	Dual-Fuel *
<b>5000</b>	6.3" ± 0.2" W.C. (1.56 ± 0.05 kPa)	6.3" ± 0.2" W.C. (1.56 ± 0.05 kPa)
<b>5000 Low Gas Pressure</b>	2.6" ± 0.2" W.C. (0.65 ± 0.02 kPa)	
<b>6000</b>	7.9" ± 0.2" W.C. (1.97 ± 0.05 kPa)	7.9" ± 0.2" W.C. (1.97 ± 0.05 kPa)
<b>6000 Low Gas Pressure</b>	1.9" ± 0.2" W.C. (0.50 ± 0.05 kPa)	

\* This column lists natural gas pressures on dual fuel units. For propane values, see Section 4.5.2.

15. Once the manifold gas pressure is within the range in Table 4-1, record this value; it will be used later, in Section 5.2: *Low Pressure Gas Test*, and Section 5.3: *High Pressure Gas Test*.
16. Press the Down ▼ arrow key until SET Valve Position appears on the display, then press CHANGE.
17. Press the Up ▲ arrow key until the *SET Valve Position* reads 100%, then press ENTER.
18. With the valve position at 100%, insert the combustion analyzer probe into the exhaust manifold probe opening (see Figure 4-2) and allow enough time for the combustion analyzer reading to stabilize.
19. Compare the combustion analyzer's oxygen readings to the O<sub>2</sub> Sensor value displayed in the Operating menu on the C-More Controller. If the values differ by more than ±1.5% and your combustion analyzer is correctly calibrated, the on-board O<sub>2</sub> sensor may be defective and need to be replaced.

**NATURAL GAS Combustion Calibration Instructions**

20. Compare the measured oxygen level to the oxygen range shown in Table 4-2. Also, ensure that the nitrogen oxide (NO<sub>x</sub>) and carbon monoxide (CO) readings do not exceed the values shown in Table 4-2. If your target NO<sub>x</sub> value is 9 ppm or less, use the values in the Ultra-Low NO<sub>x</sub> columns. If you are not in a “NO<sub>x</sub>-limited” area and/or do not have a NO<sub>x</sub> measurement in your analyzer, set the oxygen (O<sub>2</sub>) at 5.5% ± 0.5%.

**TABLE 4-2: NATURAL GAS Calibration Reading at 100% Valve Position**

Standard NO <sub>x</sub>		Ultra-Low NO <sub>x</sub>		Carbon Monoxide (CO)
Oxygen (O <sub>2</sub> ) %	Nitrogen Oxide (NO <sub>x</sub> )	Oxygen (O <sub>2</sub> ) %	Nitrogen Oxide (NO <sub>x</sub> )	
5.5% ± 0.5%	≤20 ppm	6.0% ± 1.0%	≤9 ppm	<100 ppm

21. Next, press the Down ▼ arrow key until CAL Voltage 100% is displayed.
22. Press the CHANGE key and observe that CAL Voltage 100% is flashing.
23. The oxygen level at the 100% valve position should match the value in Table 4-2. Also, ensure that the NO<sub>x</sub> and CO readings do not exceed the values in Table 4-2.
24. If the oxygen level is not within the specified range, adjust the level using the ▲ and ▼ arrow keys. This will adjust the output voltage to the blower motor as indicated on the display. Pressing the Up ▲ arrow key increases the oxygen level and pressing the down ▼ arrow key decreases the oxygen level.
25. Once the oxygen level is within the specified range at 100%, press the ENTER key to store the selected blower output voltage for the 100% valve position. Record all readings on the Combustion Calibration Sheets provided.
26. With the valve position at 100%, if the oxygen level is not within the required tolerance after adjusting the blower voltage, then the gas pressure on the downstream side of the SSOV must be adjusted using the gas pressure adjustment screw on the SSOV (Figure 4-3). Slowly rotate the gas pressure adjustment in 1/4-turn increments, clockwise to reduce O<sub>2</sub> level or counterclockwise to increase it. Allow the combustion analyzer to stabilize following each adjustment.
27. Once the oxygen level is within the specified range at 100%, record the O<sub>2</sub>, NO<sub>x</sub> and CO readings on the Combustion Calibration Data Sheets provided with the unit.
28. Lower the valve position to 70% using the ▼ arrow key.

**NOTE:**

Remaining combustion calibration steps are performed using the *Combustion Cal* menu in the C-More Controller. The combustion calibration control functions will be used to adjust the oxygen level (%) at valve position percentages described in the steps below. These instructions assume that the inlet air temperature is between 50°F and 100°F (10°C – 37.8°C). If NO<sub>x</sub> readings exceed the target values in Table 4-2, above, increase the O<sub>2</sub> level up to 1% higher than the listed calibration range. Record the increased O<sub>2</sub> value on the Combustion Calibration sheet.

**NATURAL GAS Combustion Calibration Instructions**

29. Repeat steps 21 through 25 for valve positions shown in Table 4-3a and 4-3b. The O<sub>2</sub>, NO<sub>x</sub> and CO should stay within the ranges shown in the Tables.

**TABLE 4-3a: NATURAL GAS Final Valve Positions: BMK 5000**

Valve Position		Standard NO <sub>x</sub>		Ultra-Low NO <sub>x</sub>		CO
Single Fuel	Dual Fuel	O <sub>2</sub> %	NO <sub>x</sub>	O <sub>2</sub> %	NO <sub>x</sub>	
70%		5.5% ± 0.5%	<20 ppm	6.0% ± 1.0%	≤9 ppm	<100 ppm
50%		5.5% ± 0.5%	<20 ppm	6.0% ± 1.0%	≤9 ppm	<100 ppm
40%		5.5% ± 0.5%	<20 ppm	6.0% ± 1.0%	≤9 ppm	<50 ppm
30%		5.5% ± 0.5%	<20 ppm	6.0% ± 1.0%	≤9 ppm	<50 ppm
18%		6.0% ± 1.0%	<20 ppm	6.5% ± 1.5%	≤9 ppm	<50 ppm

**NOTE:** BMK5000 Low Gas Pressure (LGP) Models do not offer Ultra Low NO<sub>x</sub> settings.

**TABLE 4-3b: NATURAL GAS Final Valve Positions: BMK 6000**

Valve Position		Standard NO <sub>x</sub>		Ultra-Low NO <sub>x</sub>		CO
Single Fuel	Dual Fuel	O <sub>2</sub> %	NO <sub>x</sub>	O <sub>2</sub> %	NO <sub>x</sub>	
70%	85%	5.5% ± 0.5%	<20 ppm	6.0% ± 1.0%	≤9 ppm	<100 ppm
50%	65%	5.5% ± 0.5%	<20 ppm	6.0% ± 1.0%	≤9 ppm	<100 ppm
40%	45%	5.5% ± 0.5%	<20 ppm	6.0% ± 1.0%	≤9 ppm	<50 ppm
30%	30%	5.5% ± 0.5%	<20 ppm	6.0% ± 1.0%	≤9 ppm	<50 ppm
18%	18%	6.0% ± 1.0%	<20 ppm	6.5% ± 1.5%	≤9 ppm	<50 ppm

**NOTE:** BMK6000 Low Gas Pressure (LGP) Models do not offer Ultra Low NO<sub>x</sub> settings.

**NOTE:**

If NO<sub>x</sub> readings exceed the target values in Table 4-3a or 4-3b, increase the O<sub>2</sub> level up to 1% higher than the range shown in the table. Record the increased O<sub>2</sub> value on the Combustion Calibration sheet.

30. If the oxygen level at the 18% valve position is too high and the Blower voltage is at the minimum value, you can adjust the TAC screw, which is recessed in the top of the Air/Fuel Valve (see Figure 4-3). Rotate the screw 1/2 turn clockwise (CW) to add fuel and reduce the O<sub>2</sub> to the specified level. Recalibration *MUST* be performed again from 50% down to the lowest valve position after making a change to the TAC screw.

This completes the NATURAL GAS combustion calibration procedure.

### 4.5.2 PROPANE GAS COMBUSTION CALIBRATION

These instructions apply only to units running **PROPANE** gas. Instructions for doing combustion calibration on a unit running Natural Gas appear in the previous section, 4.5.1.

#### PROPANE Combustion Calibration Instructions

1. Open the water supply and return valves to the unit and ensure that the system pumps are running.
2. Open the **PROPANE** supply valve to the unit and then slowly open the Pilot gas valve.
3. Set the C-More Controller's ON/OFF switch to the **OFF** position.
4. Turn external AC power to the unit ON. The display will show a description of the unit and then the time and date.
5. Press the **MENU** key on the front panel of the C-More and access the *Setup* menu, enter the password **6817** and then press the **ENTER** key.
6. Set the unit to the MANUAL mode by pressing the **AUTO/MAN** key. A flashing **Manual Valve Position** message will be displayed with the present position in % and the **MANUAL** LED will light.
7. Adjust the air/fuel valve position to **0%** by pressing the ▼ arrow key and then press **ENTER**.
8. Ensure that the leak detection ball valve downstream of the SSOV is open and the manometer is attached and functioning properly.
9. Set the ON/OFF switch to the **ON** position.
10. Press the **MENU** key on the front panel of the C-More until **COMBUSTION CAL MENU** appears on the display.
11. Press the Up ▲ arrow key until **SET Stdbby V Out** (*Standby Voltage*) setting appears. Verify that it is set to **2.0 V** (the default). AERCO recommends it be kept at 2.0 volts to prevent flue gas recirculation. Individually vented units in positive pressure boiler rooms may set **SET Stdbby V Out** to **0** volts.
12. Press the Down ▼ arrow key until **SET Valve Position** appears, then press **CHANGE**.
13. Use the Up ▲ arrow key to change the valve position to **50%**. The unit should begin its start sequence and fire.
14. Next, verify that the gas pressure downstream of the SSOV is within the range in Table 4-4 for the model you are calibrating. If gas pressure adjustment is required, remove the brass hex nut on the SSOV actuator to access the gas pressure adjustment screw (Figure 4-3). Make gas pressure adjustments using a flat-tip screwdriver to obtain a gas pressure approximately shown in Table 4-4.

**TABLE 4-4: PROPANE Gas Pressure Range @ 100% Fire Rate**

Model	Single-Fuel	Dual-Fuel
<b>5000</b>	2.0" ± 0.2" W.C. (0.50 to 0.05 kPa)	2.0" ± 0.2" W.C. (0.50 to 0.05 kPa)
<b>6000</b>	4.2" ± 0.2" W.C. (1.05 to 0.05 kPa)	4.2" ± 0.2" W.C. (1.05 to 0.05 kPa)

15. Once the manifold gas pressure is within the range in Table 4-1, record this value; it will be used later, in Section 5.2: *Low Pressure Gas Test*, and Section 5.3: *High Pressure Gas Test*.

### PROPANE Combustion Calibration Instructions

16. Press the Down ▼ arrow key until **SET Valve Position** appears on the display, then press **CHANGE**.
17. Press the Up ▲ arrow key until the **SET Valve Position** reads **100%**, then press **ENTER**.
18. With the valve position at 100%, insert the combustion analyzer probe into the exhaust manifold probe opening (see Figure 4-2 in Section 4.2.3) and allow enough time for the combustion analyzer reading to stabilize.
19. Compare the combustion analyzer's oxygen readings to the O<sub>2</sub> Sensor value displayed in the *Operating* menu on the C-More Controller. The offset value in the *Calibration* menu can be adjusted by **±3%** to make the on-board O<sub>2</sub> sensor match the value from the combustion analyzer. If the values differ by more than **±3%** and your combustion analyzer is correctly calibrated, the on-board O<sub>2</sub> sensor may be defective and need to be replaced
20. Compare the measured oxygen level to the oxygen range shown in Table 4-5. Also, ensure that the nitrogen oxide (NO<sub>x</sub>) and carbon monoxide (CO) readings do not exceed the values shown in Table 4-5. If you are not in a "NO<sub>x</sub>-limited" area and/or do not have a NO<sub>x</sub> measurement in your analyzer, set the oxygen (O<sub>2</sub>) at **5.5% ± 0.5%**.

**TABLE 4-5: PROPANE Calibration Reading at 100% Valve Position**

Model	Oxygen (O <sub>2</sub> ) %		Nitrogen Oxide (NO <sub>x</sub> )	Carbon Monoxide (CO)
	Single-Fuel	Dual-Fuel		
<b>5000</b>	5.5% ± 0.5%	5.5% ± 0.5%	≤100 ppm	<100 ppm
<b>6000</b>	5.0% ± 0.5%	5.0% ± 0.5%	≤100 ppm	<100 ppm

21. Next, press the Down ▼ arrow key until **CAL Voltage 100%** is displayed.
22. Press the **CHANGE** key and observe that **CAL Voltage 100%** is flashing.
23. The oxygen level at the 100% valve position should be as shown in Table 4-5. Also, ensure that the NO<sub>x</sub> and CO readings do not exceed the values shown in Table 4-5.
24. If the oxygen level is not within the specified range, adjust the level using the ▲ and ▼ arrow keys. This will adjust the output voltage to the blower motor as indicated on the display. Pressing the Up ▲ arrow key increases the oxygen level and pressing the down ▼ arrow key decreases the oxygen level.
25. Once the oxygen level is within the specified range at 100%, press the **ENTER** key to store the selected blower output voltage for the 100% valve position. Record all readings on the Combustion Calibration Sheets provided.
26. With the valve position at 100%, if the oxygen level is not within the required tolerance after adjusting the blower voltage, then the gas pressure on the downstream side of the SSOV must be adjusted using the gas pressure adjustment screw on the SSOV (Figure 4-3). Slowly rotate the gas pressure adjustment in 1/4-turn increments, **clockwise to reduce O<sub>2</sub> level** or **counterclockwise to increase** it. Allow the combustion analyzer to stabilize following each adjustment.
27. Once the oxygen level is within the specified range at 100%, record the O<sub>2</sub>, NO<sub>x</sub> and CO readings on the Combustion Calibration Data Sheets provided with the unit.
28. Lower the valve position to **70%** using the ▼ arrow key.



## PROPANE Combustion Calibration Instructions

**NOTE:**

Remaining combustion calibration steps are performed using the *Combustion Cal* menu in the C-More Controller. The combustion calibration control functions will be used to adjust the oxygen level (%) at valve position percentages described in the steps below. These instructions assume that the **inlet air temperature is between 50°F and 100°F (10°C – 37.8°C)**. If NO<sub>x</sub> readings exceed the target values in Table 4-5, above, increase the O<sub>2</sub> level up to 1% higher than the listed calibration range. Record the increased O<sub>2</sub> value on the Combustion Calibration sheet.

29. Repeat steps 21 through 25 for valve positions shown in Table 4-6a and 4-6b. The O<sub>2</sub>, NO<sub>x</sub> and CO should stay within the ranges shown in the tables.

**TABLE 4-6a: PROPANE Final Valve Positions: BMK 5000**

Valve Position		Oxygen (O <sub>2</sub> ) %	Nitrogen Oxide (NO <sub>x</sub> )	Carbon Monoxide (CO)
Single-Fuel	Dual-Fuel			
70%		5.5% ± 0.5%	<100 ppm	<150 ppm
50%		5.5% ± 0.5%	<100 ppm	<150 ppm
40%		5.5% ± 0.5%	<100 ppm	<150 ppm
30%		5.5% ± 0.5%	<100 ppm	<150 ppm
18%		6.0% ± 1.0%	<100 ppm	<150 ppm

**TABLE 4-6b: PROPANE Final Valve Positions: BMK 6000**

Valve Position		Oxygen (O <sub>2</sub> ) %	Nitrogen Oxide (NO <sub>x</sub> )	Carbon Monoxide (CO)
Single-Fuel	Dual-Fuel			
70%	85%	5.5% ± 0.5%	<100 ppm	<150 ppm
50%	65%	5.5% ± 0.5%	<100 ppm	<150 ppm
40%	45%	5.5% ± 0.5%	<100 ppm	<150 ppm
30%	30%	5.5% ± 0.5%	<100 ppm	<150 ppm
18%	18%	6.0% ± 1.0%	<100 ppm	<150 ppm

**NOTE:**

If NO<sub>x</sub> readings exceed the target values in Table 4-6, increase the O<sub>2</sub> level up to 1% higher than the range shown in the table. Record the increased O<sub>2</sub> value on the Combustion Calibration sheet.

30. If the oxygen level at the 18% valve position is too high and the Blower voltage is at the minimum value, you can adjust the TAC screw, which is recessed in the top of the Air/Fuel Valve (see Figure 4-3). Rotate the TAC screw 1/2 turn **clockwise (CW) to add fuel and reduce the O<sub>2</sub>** to the specified level. Recalibration **MUST** be performed again from 50% down to the lowest valve position after making a change to the TAC screw.

**This completes the PROPANE gas combustion calibration procedure.**

## 4.6 REASSEMBLY

Once the combustion calibration adjustments are properly set, the unit can be reassembled for service operation.

### Reassembly Instructions

1. Set the ON/OFF switch in the OFF position.
2. Disconnect AC power from the unit.
3. Shut off the gas supply to the unit.
4. Remove the manometer and barbed fittings and reinstall the NPT plug using a suitable pipe thread compound.
5. Remove the combustion analyzer probe from the 1/4" vent hole in the exhaust manifold and then replace the 1/4" NPT plug in the vent hole.
6. Replace all previously removed sheet metal enclosures on the unit.

## 4.7 DUAL FUEL SWITCHOVER

Dual Fuel models contain a fuel selector switch, located on the Temperature Limit panel. Instructions for switching from one fuel to the other are in Sections 4.7.1 and 4.7.2.

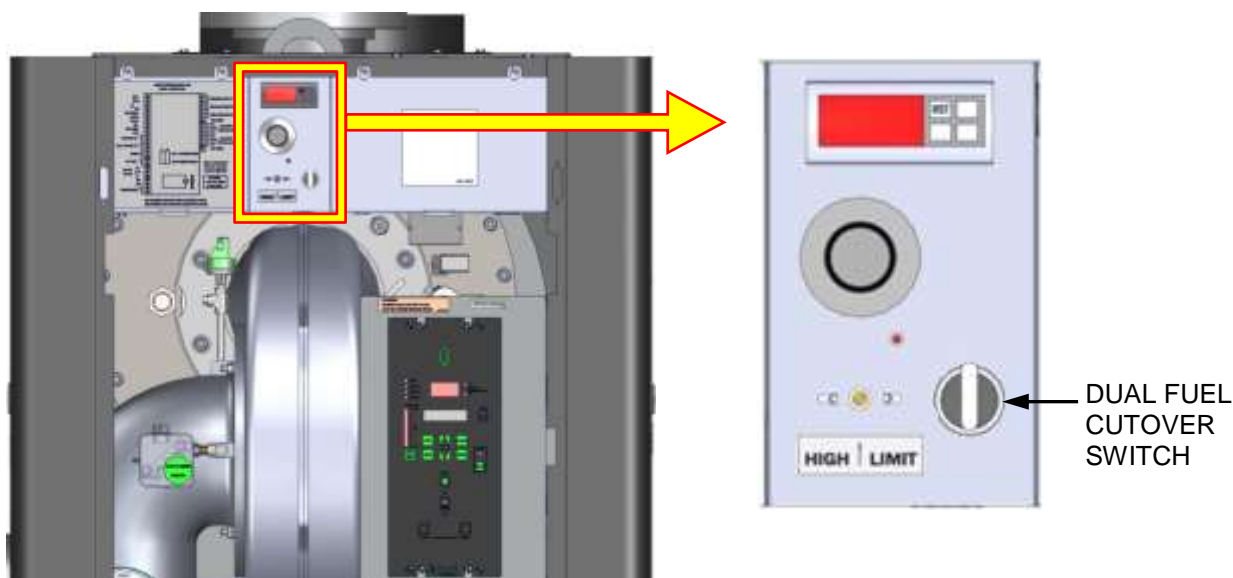

**Figure 4-4: Dual Fuel Switch Location**

### 4.7.1 Switchover from NATURAL GAS to PROPANE

#### Switchover from NATURAL GAS to PROPANE Instructions

1. Set the ON/OFF switch on the C-More Controller to the **OFF** position.
2. Close the external Natural Gas supply valves.
3. Open the external Propane gas supply valves.
4. Refer to Figure 4-4 and locate the Fuel Selector Switch on the unit, behind the front door.
5. Set the Fuel Selector Switch to the **PROPANE** position. A **GAS PRESSURE FAULT** message will be displayed on the C-More Controller.
6. Clear the Gas Pressure Fault by pressing the **CLEAR** key.
7. Set the ON/OFF switch on the C-More Controller to the **ON** position.
8. Press the **MENU** key once. **SETUP MENU** will be displayed.
9. Press the **▲** arrow key once. **PASSWORD** will be displayed.
10. Press the **CHANGE** key. **PASSWORD** will begin to flash.
11. Using the **▲** arrow key, increment the display and stop at **159**.
12. Press the **ENTER** key to store the displayed password.
13. **PASSWORD 1** will be displayed, indicating that the valid Level 1 password has been stored.
14. Next, access the *Configuration* menu by pressing the **MENU** key once.
15. Using the **▲** and **▼** arrow keys, scroll through the *Configuration* menu and stop at **Fuel Type**.
16. Press the **CHANGE** key. **FUEL TYPE** will begin to flash.
17. Press the **▲** arrow key. **PROPANE** will be displayed.
18. Press the **ENTER** key to store the *Propane Fuel type*.
19. Replace the front door panel previously removed from the boiler.

**This completes the switchover from NATURAL GAS to PROPANE.**

## 4.7.2 Switchover from PROPANE to NATURAL GAS

### Switchover from PROPANE to NATURAL GAS Instructions

1. Set the ON/OFF switch on the C-More Controller to the **OFF** position.
2. Close the external Propane Gas supply valves.
3. Open the external Natural Gas supply valves.
4. Refer to Figure 4-4 and locate the Fuel Selector Switch on the front of the unit.
5. Set the Fuel Selector Switch to the **NATURAL GAS** position. A **GAS PRESSURE FAULT** message will be displayed on the C-More Controller.
6. Clear the Gas Pressure Fault by pressing the **CLEAR** key.
7. Apply AC power to the boiler.
8. Press the **MENU** key once. **SETUP MENU** will be displayed.
9. Press the **▲** arrow key once. **PASSWORD** will be displayed.
10. Press the **CHANGE** key. **PASSWORD** will begin to flash.
11. Using the **▲** arrow key, increment the display and stop at **159**.
12. Press the **ENTER** key to store the displayed password.
13. **PASSWORD 1** will be displayed, indicating that the valid Level 1 password has been stored.
14. Next, access the *Configuration* menu by pressing the **MENU** key once.
15. Using the **▲** and **▼** arrow keys, scroll through the *Configuration* menu and stop at **FUEL TYPE**.
16. Press the **CHANGE** key. **FUEL TYPE** will begin to flash.
17. Press the **▼** arrow key. **NATURAL GAS** will be displayed.
18. Press the **ENTER** key to store the *Natural Gas Fuel* type.
19. Replace the front door panel previously removed from the boiler.

**This completes the steps necessary to switch from PROPANE Gas to NATURAL GAS.**

## 4.8 OVER-TEMPERATURE LIMIT SWITCHES

The unit contains three (3) types of over-temperature limit controls. These controls consist of a Manual Reset button, a rotary adjustable Temperature Limit switch and a digital Over-Temperature Alarm button. These controls are mounted on a plate as shown in Figure 4-5. They can be accessed by opening the front panel door of the unit.

The Manual Reset button is not adjustable and is permanently fixed at 210°F (98.9°C). This button will shut down and lock out the boiler if the water temperature exceeds 210°F (98.9°C). Following an over-temperature condition, it must be manually reset by pressing the Manual Reset button shown in Figure 4-5 before the boiler can be restarted.

The adjustable Temperature Limit switch is manually adjustable from 32°F - 212°F (0°C – 100°C). This switch allows the boiler to restart, once the temperature drops below the selected temperature setting on the dial. Set the dial on this switch to the desired setting.

The digital Over-Temperature Alarm switch shown in Figure 4-5 and 4-6 is preset at the factory to 210°F (98.9°C) and should not be changed. If an over-temperature condition is detected, this switch automatically shuts down the boiler and sounds an audible alarm. If desired, the Over-Temperature Alarm can be checked or adjusted using the procedure in Section 4.8.1.

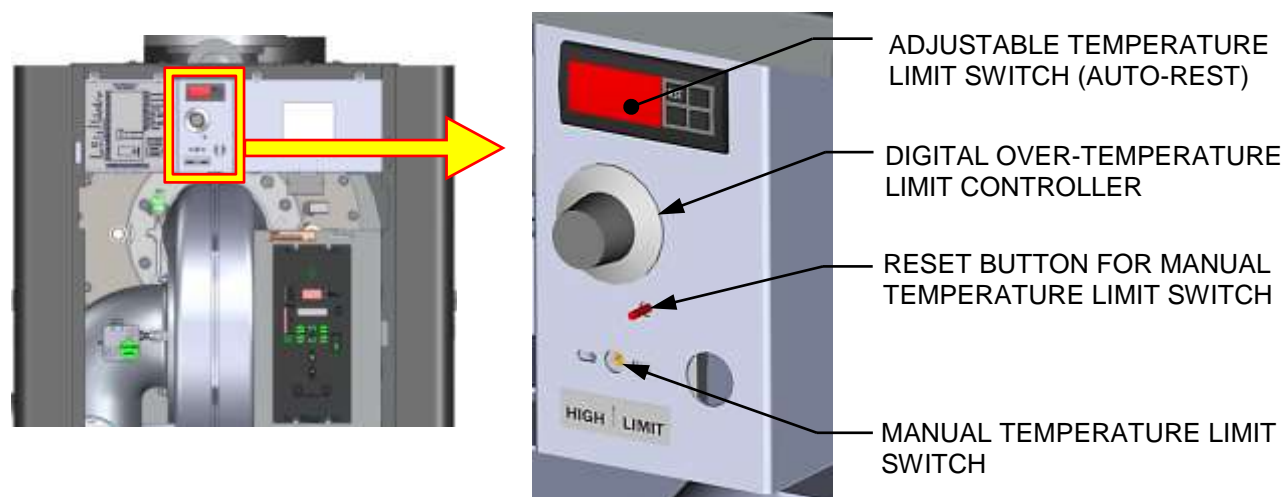



**Figure 4-5: Over-Temperature Limit Switch Location**

### 4.8.1 Digital Alarm Switch Checks and Adjustments

The **Over-Temperature Alarm** switch settings can be checked or adjusted using the controls and display on the front panel of the switch illustrated and described in Figure 4-6 and Table 4-6.



**Figure 4-6: Digital Over-Temperature Alarm Switch Front Panel**

TABLE 4-6: Over-Temperature Alarm Switch Controls and Display		
CONTROL/DISPLAY	MEANING	FUNCTION
LED Display	TEMP status	Displays current water temperature or setpoint.
RST	RESET Button	Resets the unit after an alarm condition.
	UP Button	Increases the displayed temperature.
	DOWN Button	Decreases the displayed temperature.
SET	SET Button	Used to access and store parameters in the unit.

Perform the following steps to check or adjust the **Over-Temperature Alarm** switch settings:

Over-Temp Alarm Switch Check and Adjustment Instructions
<ol style="list-style-type: none"> <li>1. Set the ON/OFF switch to the ON position.</li> <li>2. Press the SET button on the Over-Temperature Alarm switch. <i>SP</i> will appear in the display.</li> <li>3. Press the SET button again. The current over-temperature limit value stored in memory will be displayed. (Default = 210°F, 98.9°C).</li> <li>4. If the display does not show the required over-temperature alarm setting, press the ▲ or ▼ arrow button to change the display to the desired temperature setting.</li> <li>5. Once the desired over-temperature alarm setting (210°F) is displayed, press the SET button to store the setting in memory.</li> <li>6. To calibrate the offset (P1), press and hold the SET button on the Over-Temperature Alarm switch for 8 seconds. Access code value 0 should appear in the display. The switch comes from the factory with the code set at 0. AERCO recommends that you do not change this code.</li> <li>7. Press the SET button again to enter the code. The first parameter label, <i>SP</i>, will appear in the display.</li> <li>8. Using the ▲ and ▼ arrow keys, select parameter P1.</li> <li>9. Press SET to view the value stored in memory.</li> <li>10. If the desired value is not displayed, modify the setting using the ▲ and ▼ arrow keys. The value can be changed from -10° to +10° (-5.5°C to + 5.5°C) offset. Press SET to enter the value and exit to the text parameter.</li> <li>11. To exit the programming mode, press the SET and ▼ buttons simultaneously or simply wait one minute and the display will automatically exit the programming mode.</li> <li>12. Once the programming mode has been exited, the display will show the current outlet water temperature of the boiler.</li> </ol>

## SECTION 5: SAFETY DEVICE TESTING

### 5.1 TESTING OF SAFETY DEVICES

Periodic safety device testing is required to ensure that the control system and safety devices are operating properly. The boiler control system comprehensively monitors all combustion-related safety devices before, during and after the start sequence. The tests check to ensure that the system is operating as designed.

Operating controls and safety devices should be tested on a regular basis or following service or replacement. All testing must conform to local codes such as ASME CSD-1.

#### NOTES:

- MANUAL and AUTO modes of operation are required to perform the following tests. For a complete explanation of these modes, see Section 3: *Modes of Operation* in the *Benchmark 5000 – 6000 Operation and Maintenance Guide, OMM-0124 (GF-208)*.
- It is necessary to remove the front door and side panels from the unit to perform the tests described below.

#### WARNING!

Electrical voltages in this system include **120, 208, 460, 575 and 24** volts AC. Power must be removed prior to performing wire removal or other test procedures that can result in electrical shock.

### 5.2 LOW GAS PRESSURE TEST

The steps and pressure setting required to check the Low Gas Pressure switch are described below. This switch is in the normally open (N.O.) position. Refer to Figure 5-1 for the location of the switch and where to connect the water column manometer/gauge when performing the test.

The Low Gas Pressure switch is adjustable; the instructions below set it to the correct position.

#### LOW Gas Pressure Test Instructions

1. Shut off the external gas supply upstream to the unit by closing the external gas supply ball valve (not shown).
2. Remove the front panel from the boiler to access the gas train components.
3. Locate the port on the top of the Low Gas Pressure switch (see Figure 5-1) and loosen the screw inside a few turns to open it. Do not remove this screw completely. Alternatively, you can remove the 1/4 inch plug shown in Figure 5-1 and install a hose barb fitting in that location.
4. Attach one end of the plastic tubing to the port or barb fitting and the other end to a 0" W.C. to 2 psi (0 – 14 kPa) manometer.

**LOW Gas Pressure Test Instructions**

5. Apply the reading of the manifold pressure taken in Step 15 of Section 4.5.1 (Natural Gas train) and/or Section 4.5.2 (Propane gas train) and plug them into the following formulas, which calculate the *minimum* allowable gas pressure:
  - BMK 5000/6000 Natural Gas Pressure → \_\_\_\_ x 0.5 + 6.0 = \_\_\_\_ min gas pressure
  - BMK 5000 LGP \* Natural Gas Pressure → \_\_\_\_ x 0.5 + 0.9 = \_\_\_\_ min gas pressure
  - BMK 6000 LGP \* Natural Gas Pressure → \_\_\_\_ x 0.5 + 1.3 = \_\_\_\_ min gas pressure
  - BMK 5000/6000 Propane Gas Pressure → \_\_\_\_ x 0.5 + 3.7 = \_\_\_\_ min gas pressure

\* LGP refers to Low Gas Pressure models
6. Remove the cover from the Low Gas Pressure switch and set the dial indicator to 2 (the minimum).
7. Open the external gas supply ball valve upstream of the unit.
8. Place the unit in MANUAL mode and adjust the Air/Fuel Valve position (% open) to 100%.
9. While the unit is firing, read the CO value on the combustion analyzer and slowly decrease the incoming gas supply pressure until the CO reading is approximately 300 ppm.
10. Take a reading of the inlet gas pressure. If the inlet pressure is below the minimum calculated in step 5, above, then increase the pressure to match the calculated minimum.
11. Slowly turn the indicator dial on the Low Gas Pressure switch until the unit shuts down due to a gas pressure fault.
12. Readjust the inlet gas pressure to what it was prior to the test.
13. Press the CLEAR button on the Control Panel to clear the fault.
14. The fault message should clear and the FAULT indicator should go off. The unit should now restart.
15. For Dual Fuel units, repeat the previous procedure on the PROPANE gas train, starting with the PROPANE Low Gas Pressure Switch, shown in the bottom-half of Figure 5-1.



SECTION 5: SAFETY DEVICE TESTING

**LOW Gas Pressure Test Instructions**

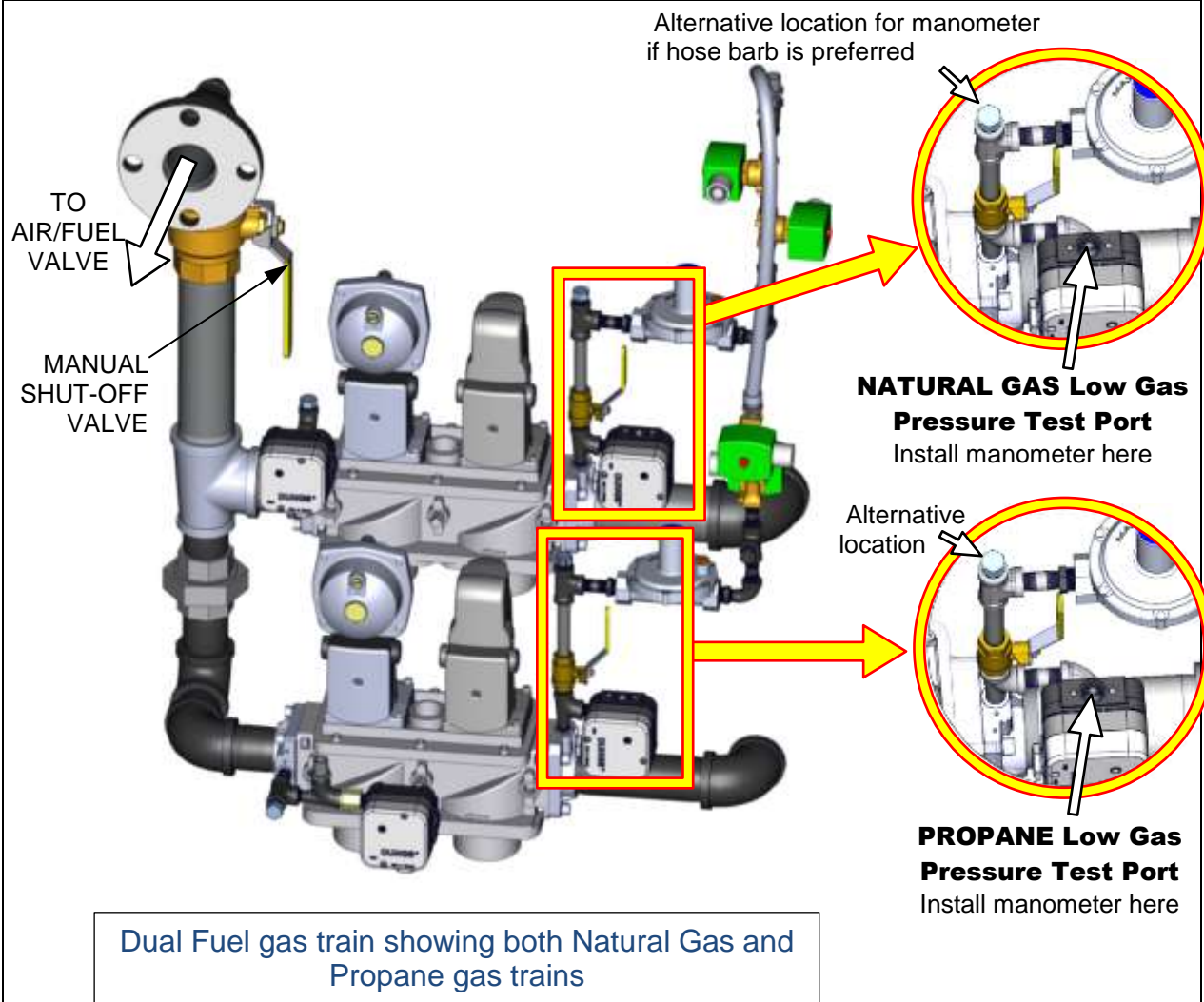

*Figure 5-1: Low Gas Pressure Switch Locations & Test Ports*

**5.3 HIGH GAS PRESSURE TEST**

To simulate a high gas pressure fault perform the following steps:

**HIGH Gas Pressure Test Instructions**

1. Shut off the **external** gas supply by closing the external gas supply ball valve.
2. Locate the port on the top of the **NATURAL GAS High Gas Pressure Switch** (see Figure 5-3) and loosen the screw inside a few turns to open it. Do not remove this screw completely. Alternatively, you can remove the 1/4 inch plug shown in the top half of Figure 5-3 and install a hose barb fitting in that location.
3. Attach one end of the plastic tubing to the port or barb fitting and the other end to a **0 – 16” W.C. (0 – 4.0 kPa)** manometer.

**HIGH Gas Pressure Test Instructions**

4. Apply the reading of the manifold pressure taken in Step 15 of section 4.5.1 (Natural Gas train) and/or 4.5.2 (Propane gas train), and plug them into the following formulas, which calculate the maximum allowable gas pressure:
  - Natural Gas Pressure → \_\_\_\_\_ x 1.5 = \_\_\_\_\_ max gas pressure
  - Propane Gas Pressure → \_\_\_\_\_ x 1.5 = \_\_\_\_\_ max gas pressure
5. Remove the cover from the High Gas Pressure switch and set the dial indicator to 20 (the maximum).
6. Open the **external** gas supply ball valve upstream of the unit.
7. Start the unit in MANUAL mode and adjust the Air/Fuel Valve position to bring the unit up to 100%,
8. Slowly increase the manifold gas supply pressure by turning the Gas Pressure Adjustment Screw in the Downstream SSOV (see Figure 5-2) while reading the CO level on the combustion analyzer. Adjust the manifold pressure until the CO reading is **300 ppm**. Note the number of turns you make, as you will turn it back to its original position in step 11, below.



**Figure 5-2: SSOV with Gas Pressure Adjustment Screw Location**

9. Take a reading of the manifold gas pressure. If the manifold pressure is greater than the maximum calculated in step 3, then use the Gas Pressure Adjustment Screw to decrease the manifold pressure until it is at the maximum allowed.
10. Slowly turn the indicator dial on the High Gas Pressure Switch until the unit shuts down due to a gas pressure fault. This is the setpoint.
11. Readjust the manifold gas supply pressure to what it was before it was increased in step 8.
12. Press the **CLEAR** button on the Control Panel to clear the fault.
13. Upon test completion, remove the manometer, and turn the NATURAL GAS High Gas Pressure Switch port screw clockwise until port is closed.
14. For Dual Fuel gas trains, repeat this procedure on the PROPANE gas train, starting with opening the port on the side of the PROPANE High Gas Pressure Switch, as shown in Figure 5-3.

SECTION 5: SAFETY DEVICE TESTING

**HIGH Gas Pressure Test Instructions**

Alternative location for manometer if hose barb is preferred

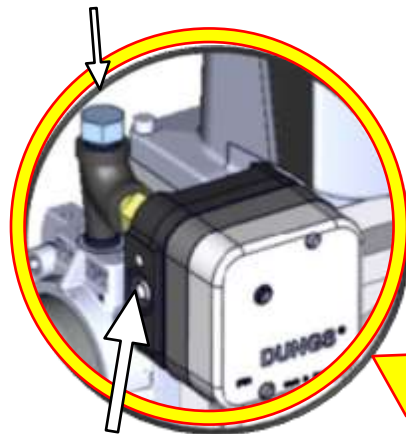

**NATURAL GAS High Gas Pressure Port**  
Install manometer here for High Gas Pressure test

NATURAL GAS HIGH GAS PRESSURE SWITCH

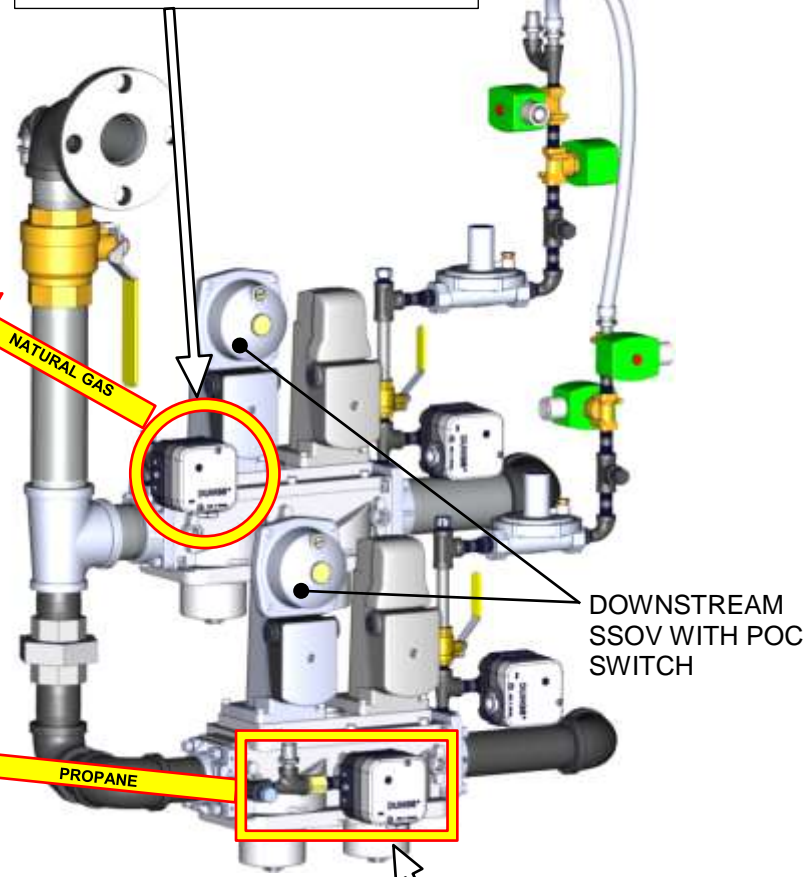

DOWNSTREAM SSOV WITH POC SWITCH

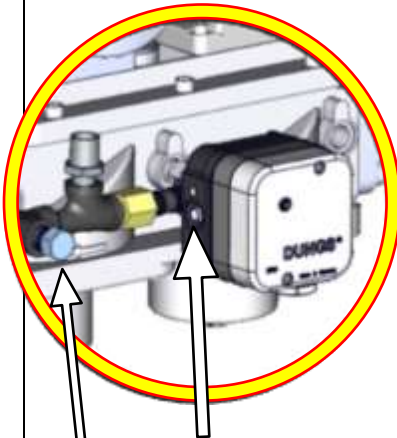

**PROPANE Gas Pressure Port**  
Install manometer here for High Gas Pressure test

PROPANE HIGH GAS PRESSURE SWITCH

Alternative location for manometer if hose barb is preferred

**Figure 5-3: High Gas Pressure Switch Locations & Test Ports**

## 5.4 LOW WATER LEVEL FAULT TEST

To simulate a low water level fault, proceed as follows:

### LOW Water Fault Test Instructions

1. Set the ON/OFF switch to the OFF position.
2. Close the water shut-off valves in the supply and return piping to the unit.
3. Slowly open the drain valve on the rear of the unit. If necessary the unit's relief valve may be opened to aid in draining.
4. Continue draining the unit until a *LOW WATER LEVEL* fault message is displayed and the FAULT indicator flashes.
5. Place the unit in the MANUAL mode and raise the valve position above 30%.
6. Set the ON/OFF switch to the ON position. The READY light should remain off and the unit should not start. If the unit does start, shut the unit off immediately and refer the fault to qualified service personnel.
7. Close the drain and pressure relief valve used in draining the unit.
8. Open the water shut-off valve in the return piping to the unit.
9. Open the water supply shut-off valve to the unit to refill.
10. After the shell is full, press the LOW WATER LEVEL RESET button to reset the low water cutoff.
11. Press the CLEAR button to reset the FAULT LED and clear the displayed error message.
12. Set the ON/OFF switch to the ON position. The unit is now ready for operation.

## 5.5 WATER TEMPERATURE FAULT TEST

A high water temperature fault is simulated by adjusting the automatic Over-Temperature switch. This switch is accessible from the front of the unit as shown in Figure 5-4, below.

### Water Temperature Fault Test Instructions

1. Start the unit in the normal operating mode. Allow the unit to stabilize at its setpoint.
2. Lower the adjustable Over-Temperature switch setting to match the displayed *OUTLET TEMPERATURE*.
3. Once the adjustable Over-Temperature switch setting is approximately at, or just below, the actual outlet water temperature, the unit should shut down. The *FAULT* indicator should start flashing and a *HIGH WATER TEMP SWITCH OPEN* fault message should be displayed. It should not be possible to restart the unit until the water temperature is below the new setpoint.
4. Reset the adjustable Over-Temperature switch to its original setting.
5. The unit should start once the adjustable Temperature Limit switch setting is above the actual outlet water temperature.

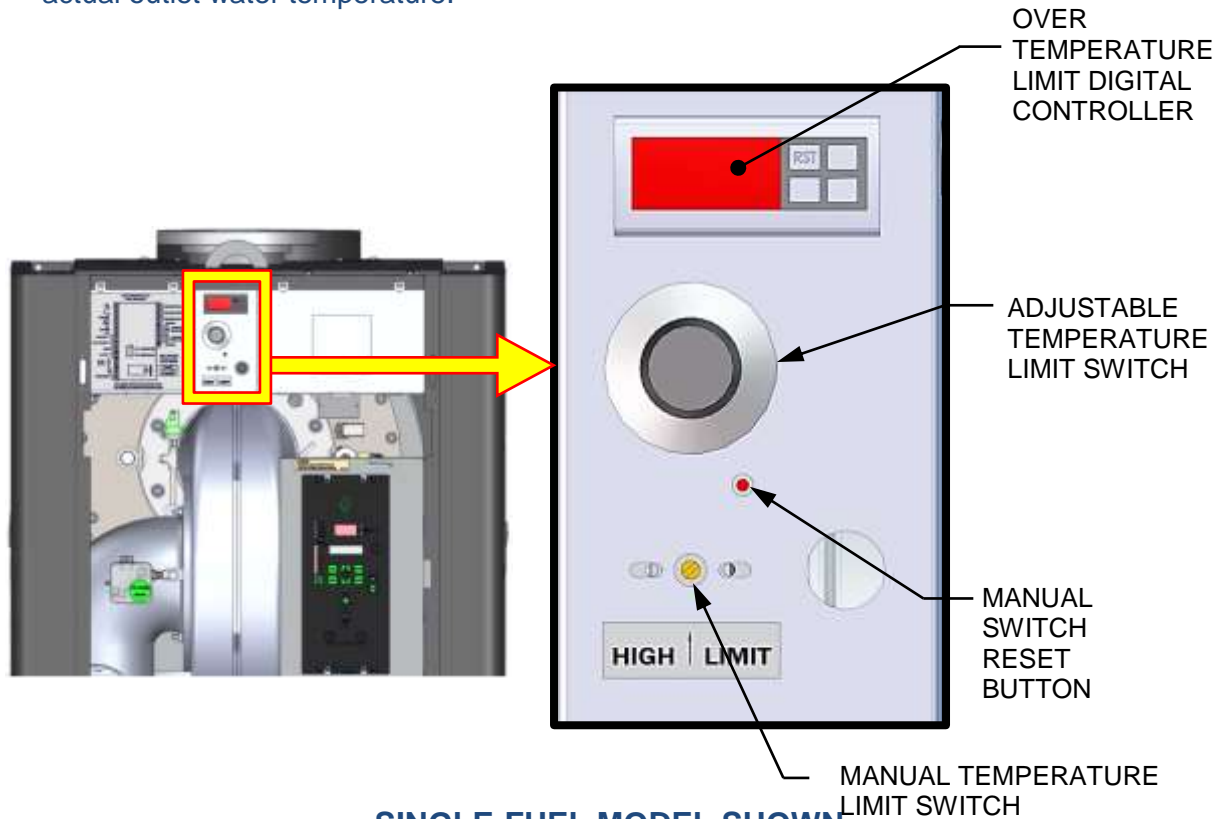

**SINGLE-FUEL MODEL SHOWN**

**Figure 5-4: Temperature Limit Switch Location**

## 5.6 INTERLOCK TESTS

The unit is equipped with two interlock circuits called the Remote Interlock and Delayed Interlock. Terminal connections for these circuits are located in the I/O Box (Figure 2-14) and are labeled *REMOTE INTL'K IN* and *DELAYED INTL'K IN*. These circuits can shut down the unit in the event that an interlock is opened. These interlocks are shipped from the factory jumpered (closed). However, each of these interlocks may be utilized in the field as a remote stop and start, an emergency cut-off, or to prove that a device such as a pump, gas booster, or louver is operational.

### 5.6.1 Remote Interlock Test

#### Remote Interlock Test Instructions

1. Remove the cover from the I/O Box and locate the *REMOTE INTL'K IN* terminals.
2. Start the unit in the *MANUAL* mode and set the valve position between 25% and 30%.
3. If there is a jumper across the *REMOTE INTL'K IN* terminals, remove one side of the jumper. If the interlock is being controlled by an external device, either open the interlock via the external device or disconnect one of the wires leading to the external device.
4. The unit should shut down and display *INTERLOCK OPEN*.
5. Once the interlock connection is reconnected, the *INTERLOCK OPEN* message should automatically clear and the unit should restart.

### 5.6.2 Delayed Interlock Test

#### Delayed Interlock Test Instructions

1. Remove the cover from the I/O Box and locate the *DELAYED INTL'K IN* terminals.
2. Start the unit in the *MANUAL* mode at a valve position between 25% and 30%.
3. If there is a jumper across the *DELAYED INTL'K IN* terminals, remove one side of the jumper. If the interlock is connected to a proving switch of an external device, disconnect one of the wires leading to the proving switch.
4. The unit should shut down and display a *DELAYED INTERLOCK OPEN* fault message. The *FAULT LED* should be flashing.
5. Reconnect the wire or jumper removed in step 3 to restore the interlock.
6. Press the *CLEAR* button to reset the fault
7. The unit should start.

## 5.7 FLAME FAULT TEST

Flame faults can occur during ignition or while the unit is already running. To simulate each of these fault conditions, proceed as follows:

### Flame Fault Test Instructions

1. Set the ON/OFF switch to the **OFF** position.
2. Place the unit in the **MANUAL** mode and set the valve position **between 25% and 30%**.
3. Close the manual gas shutoff valve located between the Safety Shut-Off Valve (SSOV) and the Air/Fuel Valve, as shown on Figure 5-5, below.
4. It may be necessary to jump out the High Gas Pressure switch.
5. Set the ON/OFF switch to the **ON** position to start the unit.
6. The unit should purge and light the Pilot flame and then shut down after reaching the main Burner Ignition cycle and display **FLAME LOSS DURING IGN.**
7. Open the valve previously closed in step 3 and press the **CLEAR** button.
8. Restart the unit and allow it to prove flame.
9. Once flame is proven, close the manual gas valve located between the SSOV and the Air/Fuel Valve (see Figure 5-5, below).
10. The unit should shut down and Lockout. A flashing **FLAME LOSS DURING RUN** should appear in the display.
11. Open the valve previously closed in step 9.
12. Press the **CLEAR** button. The unit should restart and fire.

## 5.8 AIR FLOW FAULT TESTS

These tests check the operation of the **Blower Proof** switch and **Blocked Inlet** switch shown in Figure 5-5.

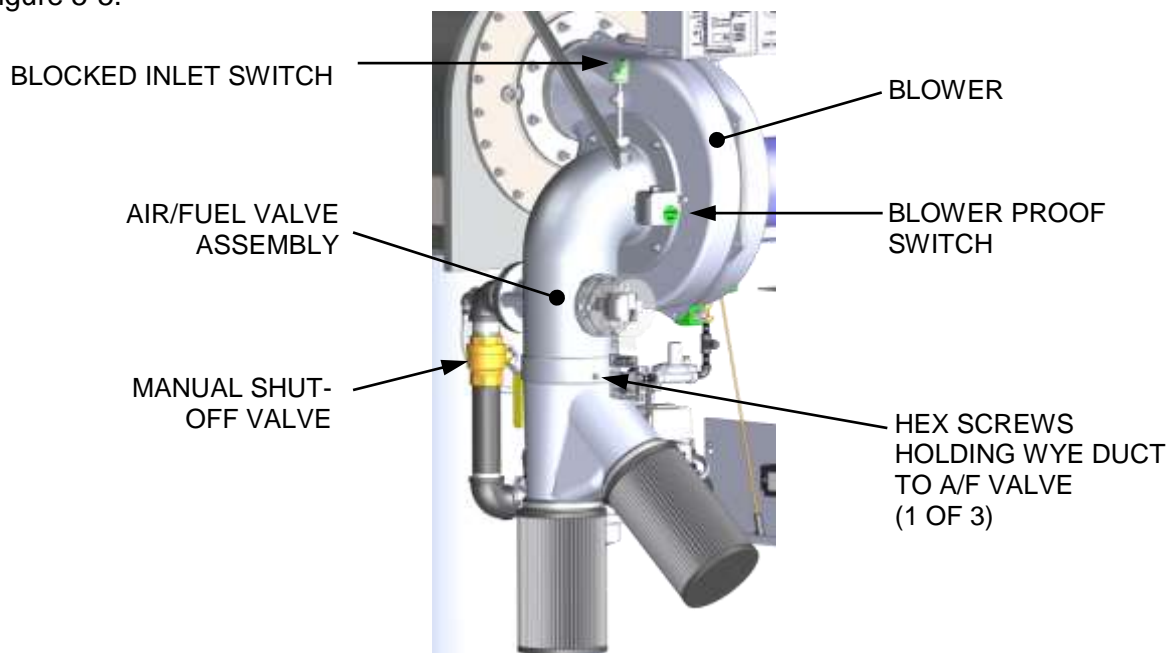

**Figure 5-5: Blower Proof & Blocked Inlet Switch Locations**

### 5.8.1 Blower Proof Switch Test

Complete the test below to check the operation of the Blower Proof switch shown in Figure 5-5.

#### Blower Proof Switch Test Instructions

1. Set the Controller's **On/Off** switch to **Off**.
2. Remove the side and/or front panels to gain access to the Blower Proof Switch (see Figures above for location).
3. Use a Phillips head screw driver to remove the front cover from the switch to reveal the switch setting indicator dial (0.3 in the Figure below).



COVER WITH LABEL

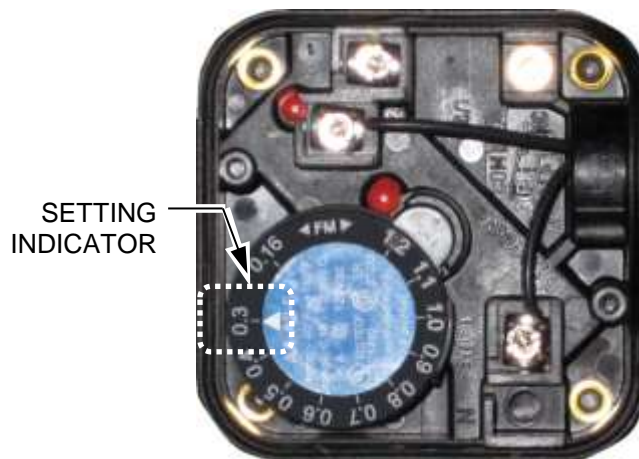

COVER REMOVED

*Figure 5-6: Blower Proof Switch*

4. Set the Controller's **On/Off** switch to **On** and wait for the boiler to go into the Purge sequence.
5. After about 5 seconds, with air flowing into the combustion chamber, slowly turn the dial clock-wise (to higher value) until the unit trips off with an **Air Flow Fault During Purge** message. Optionally, you could attach a manometer and measure the setting at the trip point.
6. After the boiler shuts down, reset the dial indicator to its original position, shown on the switch cover label, then replace the switch cover.
7. Reset the boiler.



## 5.8.2 Blocked Inlet Switch Test

This test will be run in simulated fire mode, with the Blocked Inlet switch isolated from the rest of the control circuitry.

### Blocked Inlet Switch Test Instructions

1. Turn the main ON/OFF switch on the front of the control panel to the OFF position.
2. Remove the air filter (see Figure 5-5, above).

#### WARNING!

The blower suction is very strong and can pull nearby objects into the blower's fan blades. Do NOT allow anything to be pulled into the blower! Do not wear anything that could get caught and pull you into the blower.

3. Turn off the gas supply ball valve to the boiler and then complete the following steps:
  - a) Use jumper wires to jump out the Low Gas Pressure switch and the Blower Proof switch.
  - b) Remove the black connector boot from the Flame Detector.
  - c) Connect the Flame Signal Generator to the black connector boot.

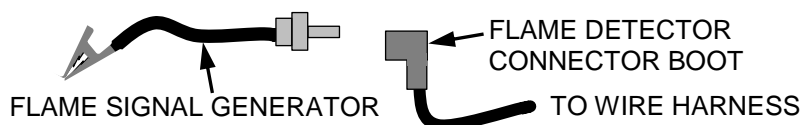

**Figure 5-7: Connecting the Flame Signal Generator**

- d) Keep the alligator clip away from bare metal parts until step 4c.
4. Complete the following with the boiler operating in MANUAL mode:
  - a) Ramp the boiler up to 100% fire rate and then turn the main ON/OFF switch on the front of the control panel to the ON position.
  - b) Push the BACK button three (3) times to return to the upper level menu.
  - c) When the C-More Controller gets into the ignition phase, the control panel will show *IGNITION TRIAL*. At that point attach the alligator clip (see Figure 5-7) to any bare metal surface or ground. The C-More Controller should now show *FLAME PROVEN* and begin to ramp up to 100% fire rate. Note that no gas or flame is present in the boiler at this time.
5. Wait for the boiler to ramp up to at least 90% before continuing.
6. Cover the combustion air inlet opening with a solid, flat object, such as a piece of thick plywood or a thick metal plate.
7. The unit should shut down and display *AIRFLOW FAULT DURING RUN*. This step confirms proper operation of the Blocked Inlet switch.
8. Remove the cover from the air inlet opening and reinstall the Combustion Air Duct or air filter.
9. Remove the jumper wires installed in step 3 and replace the black connector boot on the Flame Detector.
10. Press the CLEAR button. The unit should restart.

## 5.9 SSOV PROOF OF CLOSURE SWITCH CHECK

The SSOV, shown in Figure 5-8, contains the **Proof of Closure** switch. The **Proof of Closure** switch circuit is checked as follows:

### SSOV Proof Of Closure Switch Check Instructions

1. Set the unit's ON/OFF switch to the OFF position.
2. Place the unit in MANUAL mode and set the valve position between 25% and 30%.
3. Remove the cover from the SSOV by loosening the screw shown in Figure 5-8. Lift off the cover to access the terminal wiring connections.
4. Disconnect wire #148 from the SSOV to "open" the Proof Of Closure switch circuit.
5. The unit should fault and display *SSOV SWITCH OPEN*.
6. Replace wire #148 and press the CLEAR button.
7. Set the ON/OFF switch to the ON position to start the unit.
8. Remove the wire again when the unit reaches the purge cycle and *PURGING* is displayed.
9. The unit should shut down and display *SSOV FAULT DURING PURGE*.
10. Replace the wire on the SSOV and press the CLEAR button. The unit should restart.



**Figure 5-8: SSOV Actuator Cover Location**

## 5.10 PURGE SWITCH OPEN DURING PURGE

The **Purge** switch (and **Ignition** switch) is located on the Air/Fuel Valve. To check the switch, proceed as follows:

### Purge Switch Open During Purge Check Instructions

1. Set the unit's ON/OFF switch to the **OFF** position.
2. Place the unit in MANUAL mode and set the valve position **between 25% and 30%**.
3. Remove the Air/Fuel Valve cover by rotating the cover counterclockwise to unlock it (see Figure 5-9).
4. Remove one of the two wires (#171 or #172) from the Purge switch (Figure 5-10).
5. Initiate a unit start sequence.
6. The unit should begin its start sequence, then shut down and display **PRG SWITCH OPEN DURING PURGE**.
7. Replace the wire on the **Purge** switch and depress the **CLEAR** button. The unit should restart.

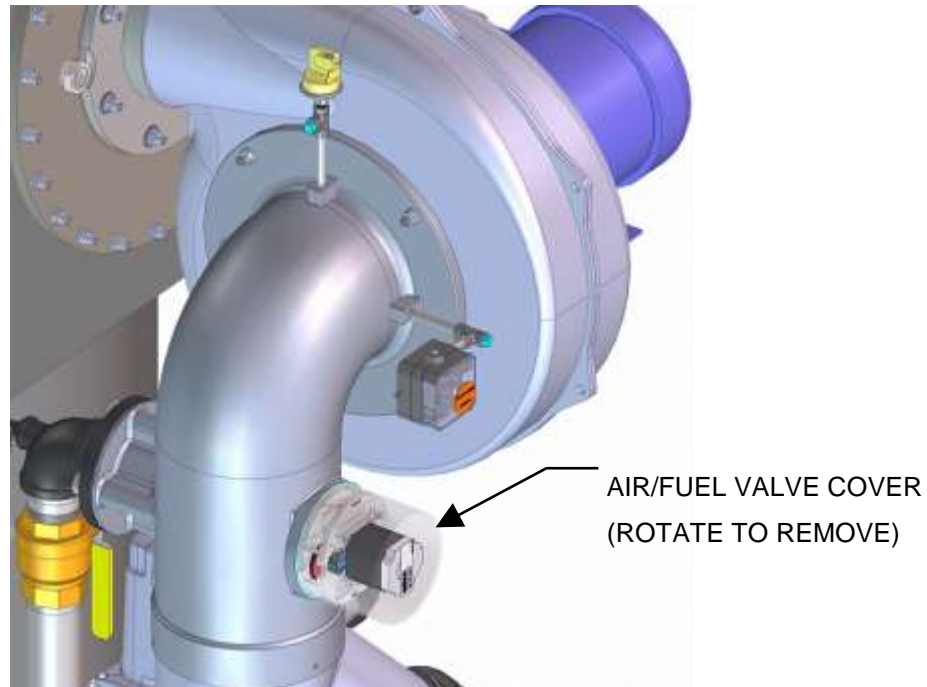

**Figure 5-9: Air/Fuel Valve Cover Location**

## SECTION 5: SAFETY DEVICE TESTING

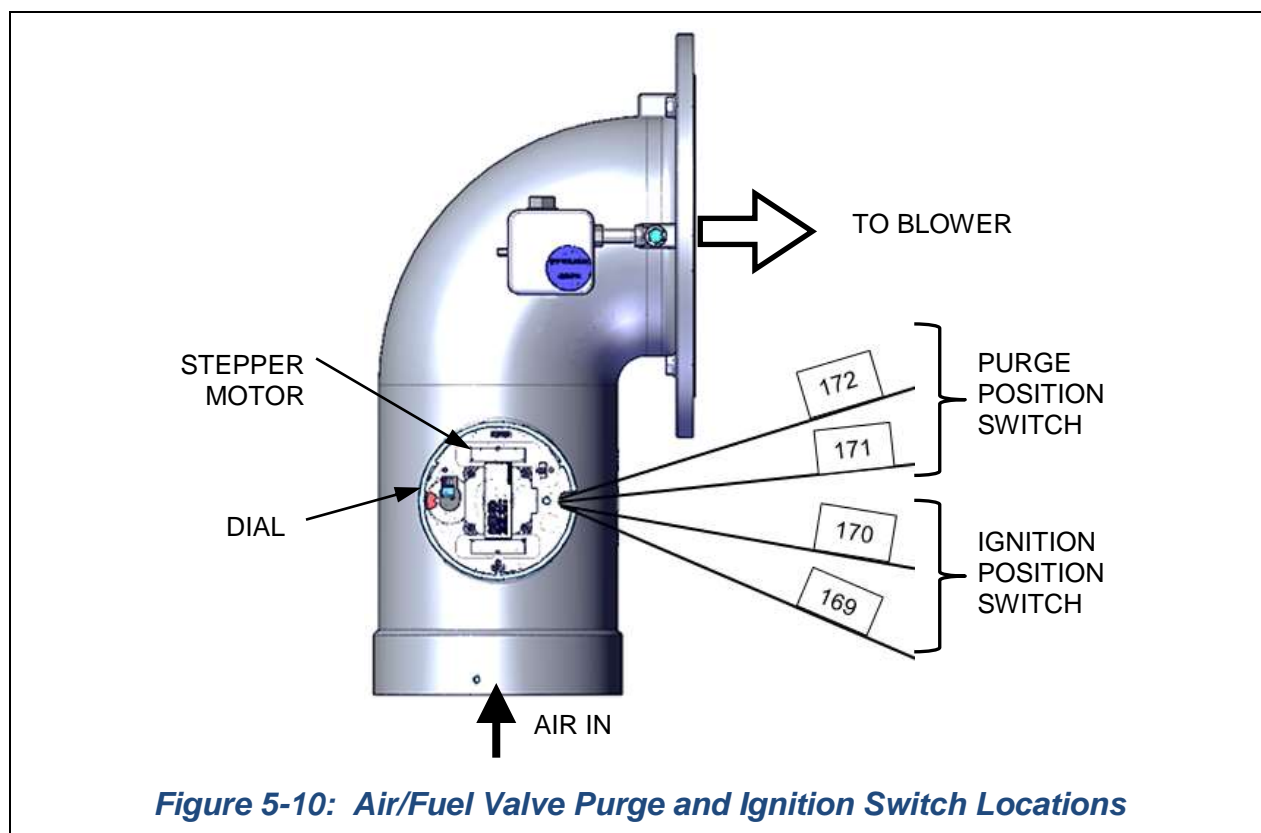

### 5.11 IGNITION SWITCH OPEN DURING IGNITION

The **Ignition** switch (and the **Purge** switch) is located on the Air/Fuel Valve. To check the switch, proceed as follows:

#### Ignition Switch Open During Ignition Check Instructions

1. Set the unit's ON/OFF switch to the OFF position.
2. Place the unit in MANUAL mode and set the valve position between 25% and 30%.
3. Remove the Air/Fuel Valve cover (Figure 5-9, above) by rotating the cover counterclockwise to unlock and lift up to remove.
4. Remove one of the two wires (#169 or #170) from the Ignition switch (see Figure 5-10, above).
5. Initiate a unit start sequence.
6. The unit should begin its start sequence and then shut down and display *IGN SWITCH OPEN DURING IGNITION*.
7. Replace the wire on the Ignition switch and press the CLEAR button. The unit should restart.

### 5.12 SAFETY PRESSURE RELIEF VALVE TEST

Test the safety Pressure Relief Valve in accordance with ASME Boiler and Pressure Vessel Code, Section VI.

# SECTION 6: BOILER SEQUENCING TECHNOLOGY

## 6.1 INTRODUCTION

The Boiler Sequencing Technology system (BST) is built into the C-More Controller. BST is an integrated 8 boiler control system. It has its own sophisticated PID control system designed to simultaneously control the light off and modulation of up to 8 boilers while achieving maximum operational efficiency.

BST is designed to ensure that all Boilers in the system operate at maximum efficiency. This is accomplished by lighting off boilers only when all ignited boilers reach or exceed a defined Valve Position (Fire Rate). Operating all boilers below the defined Fire Rate “Next on VP” (for Next Turn on Valve Position) insures that they are firing at their most efficient Fire Rate. One unit the BST network is defined as the “Manager” unit and all other units on the network are defined as “Client” units. The Manager monitors the system Header Temperature, and also monitors all Client unit’s status information, efficiently controlling all units in order to achieve and maintain the required BST Setpoint Temperature.

When there is a demand, the Manager will light off one of the boilers based on the BST Sequencing selection in the BST menu. As system load increases and the valve position of the ignited unit(s) reach the Next On VP (% valve position), the Manager will light off the next available unit. A simplified block diagram of multiple Boilers connected to a BST is shown in Figure 6-1 below.

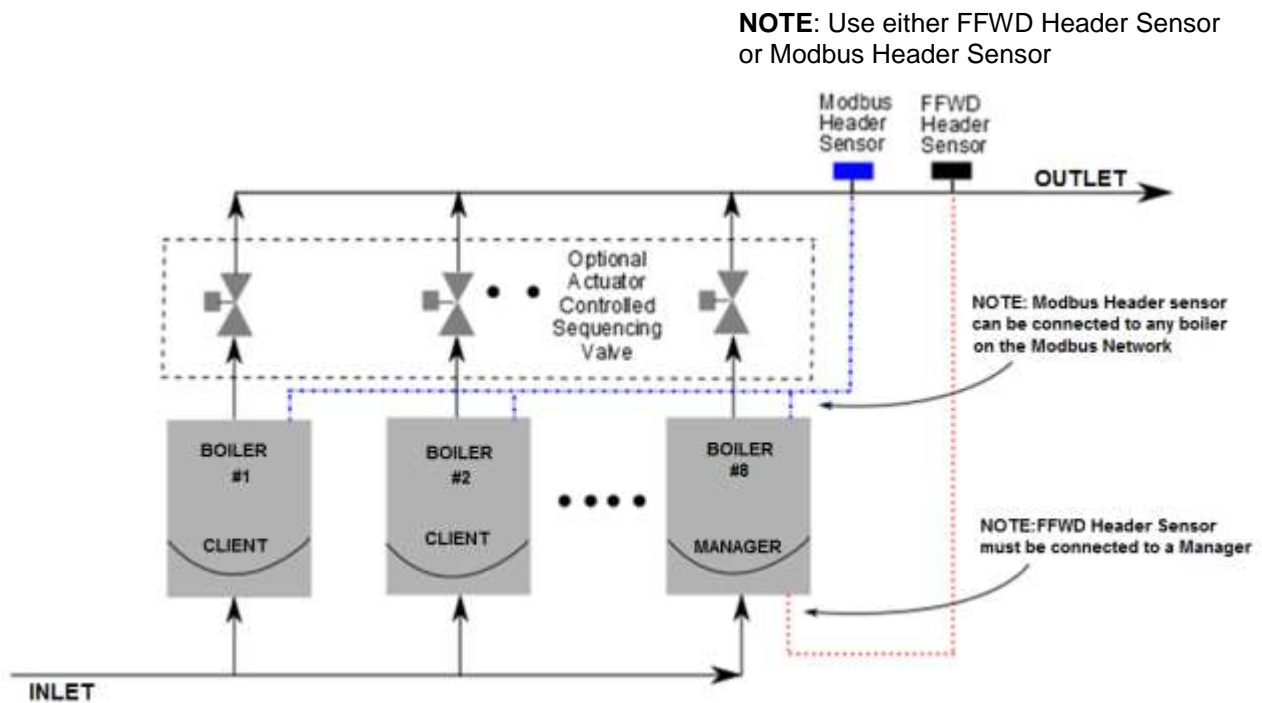

**Figure 6-1: Simplified BST Block Diagram**

**NOTE:**

After the boiler load is satisfied, the isolation valve remains open for a programmed interval (default = 2 minutes) before closing. When the *system load* is satisfied, the panel will open the isolation valves for all of the boilers. The BST controls the valves via a 0-20 mA signal (see Section 2.11.8, above)

### 6.1.1 Installation Notes

If you are installing a BST system that also includes a ProtoNode SSD (Client-Client Device), you **must** adhere to the procedure listed below. Failure to complete these steps can result in the failure of the BST system.

- a) Do **NOT** install the ProtoNode device at the outset of the installation. If the ProtoNode Device is already installed, you must physically disconnect it from the Modbus network in I/O board.
- b) Make sure that the Modbus load and bias resistors are properly configured for the system to operate without the ProtoNode installed.
- c) Temporarily set the BST system for CONSTANT SETPOINT mode of operation (see below).
- d) Turn on and completely test the installation to verify that it is operating proper.
- e) Once the installation is working properly as a BST system, install the ProtoNode device.
- f) Make sure that the Modbus load and bias resistors are properly configured for the system to operate with the ProtoNode installed.
- g) Set the BST system for desired mode of operation (SETPOINT mode).
- h) Test the system completely with the ProtoNode installed.

## 6.2 AERCO BST QUICK START CHART

Select the single option that suites your installation and then complete the instructions in the corresponding sub-section of Section 6.3 *BST Implementation Instructions*.

<b>Constant Setpoint (choose option 1 or 2)</b>	
Option 1 – Direct Wired Header (Header Temp)	Complete Section 6.3.1
Option 2 – Modbus Header (Network)	Complete Section 6.3.2
<b>Outdoor Reset (choose option 3 or 4)</b>	
Option 3 – Direct Wired Header AND Direct Wired Outdoor Air	Complete Section 6.3.3
Option 4 – Modbus Header AND Modbus Outdoor Air	Complete Section 6.3.4
<b>Remote Setpoint (choose option 5 through 8)</b>	
Option 5 – 4-20ma Drive AND Direct Wired Header	Complete Section 6.3.5
Option 6 – Modbus Drive via ProtoNode AND Direct Wired Header	Complete Section 6.3.6
Option 7 – 4-20ma Drive AND Modbus Header	Complete Section 6.3.7
Option 8 – Modbus Drive via ProtoNode AND Modbus Header	Complete Section 6.3.8

## 6.3 BST Implementation Instruction

There are 8 BST implementation options, described below. The instructions for each refer to I/O board connections described in Section 2.11.

All instructions in the sections below refer to one or more of the following components:

- Modbus Transmitter:
  - P/N **24444-1** includes PT1000 Header Temp Sensor P/N **61058**, box and power supply.
  - P/N **24444-3** includes PT1000 Header Temp Sensor P/N **61058**.
- Header Temp Sensor, either:
  - P/N **61040 (BALCO)** if connecting directly to I/O board.
  - P/N **61058 (PT1000)** dual bead, if connecting to Modbus Transmitter
- Outdoor Sensor, either:
  - P/N **61047 (BALCO)** if connecting directly to I/O board.
  - P/N **61060 (PT1000)** if connecting to Modbus Transmitter.

### 6.3.1 OPTION 1 - Constant Setpoint with Direct Wired Header Sensor

#### OPTION 1 - Constant Setpoint with Direct Wired Header Sensor

##### Step 1: HEADER TEMP SENSOR WIRING – BST MANAGER Unit

1. On the **BST Manager** unit, connect the **Header Temp Sensor** to the Feed Forward (FFWD) terminals on the P-1 Harness via the terminal block labeled *Header Temp sensor* in the I/O Box.

**NOTES:**

- The **Header Temp Sensor** must be installed between 2 and 10 feet (0.61 and 3.1m) downstream of the **last** boiler in the plant’s supply water header.
- Shielded pair 18 - 22 AWG cable is recommended for **Header Temp Sensor** wiring. There is no polarity to be observed.
- The ground for the shield is at the “SHLD” terminal in the I/O the Box. The sensor end of the shield must be left free and ungrounded.

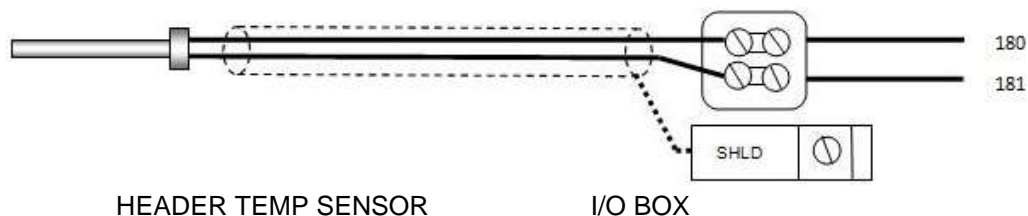

##### Step 2: CONNECT BOILERS IN DAISY CHAIN

1. Connect the boilers in a daisy chain, as shown below.

**Continued on next page**

SECTION 6: BOILER SEQUENCING TECHNOLOGY

OPTION 1 - Constant Setpoint with Direct Wired Header Sensor

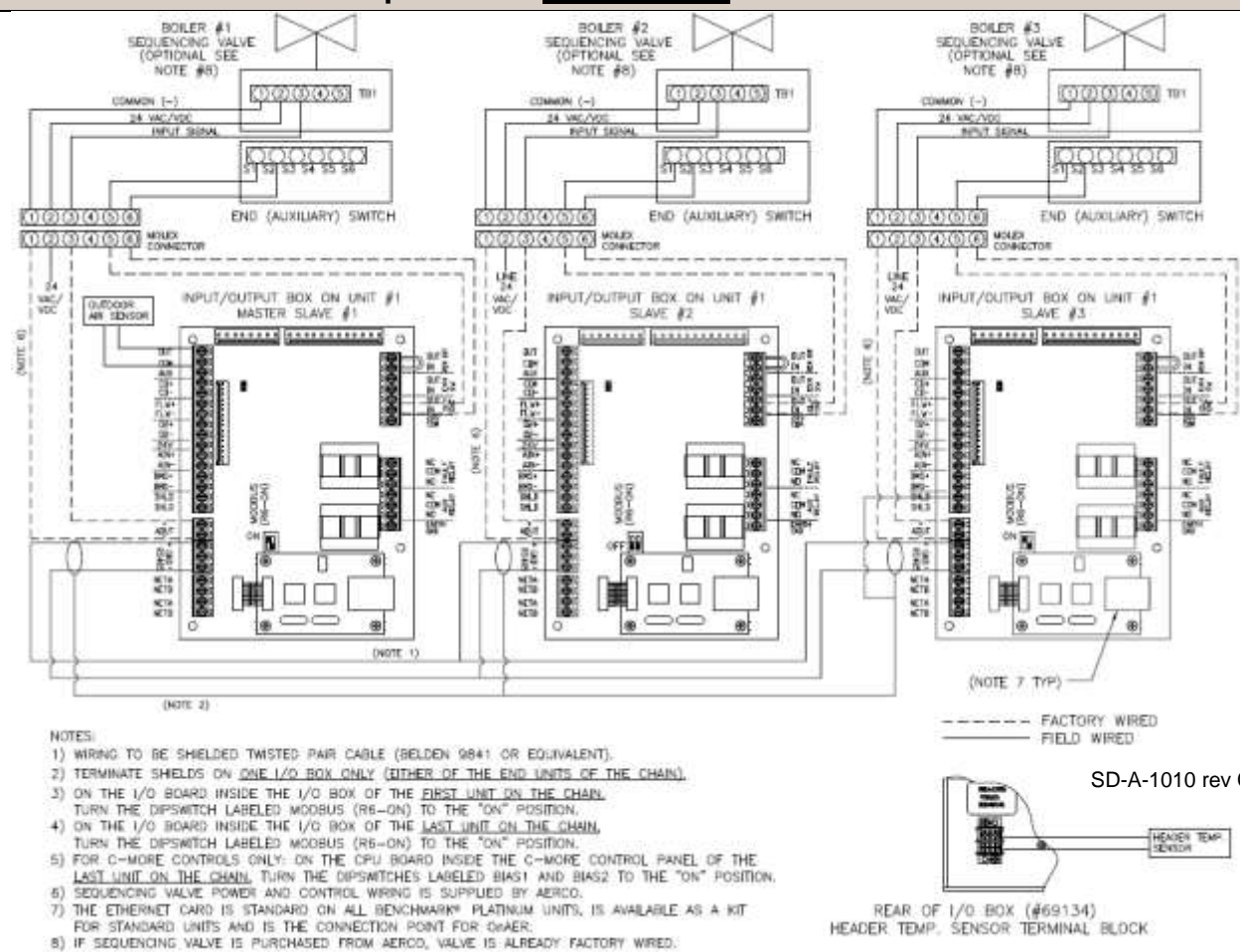

Step 3: Configure ALL C-More Units

On ALL Boilers:

1. Go to the *Configuration* menu and set the BST Menu item to **Enabled**.
2. Go to the Boiler Sequencing Menu and set the BST Mode item to **BST Client** (for now).

On MANAGER only:

3. Go to the BST Setpoint item and enter the desired Setpoint.
4. Go to the BST Setup menu item and set to **Enabled**.
5. Go to the BST Setpoint Mode item and select **Constant Setpoint**.
6. Go to the Head Temp Source item and select **FFWD Temp**.

When ALL C-More units have been configured:

7. Go to the Boiler Sequencing Menu of the Manager unit and set the BST Mode item to **BST MANAGER**.



### 6.3.2 OPTION 2 - Constant Setpoint with Modbus Wired Header Sensor

#### OPTION 2 - Constant Setpoint with Modbus Wired Header Sensor

##### Step 1: MODBUS HEADER TEMP SENSOR WIRING – ANY BOILER

Using the Modbus Transmitter gives the plant the ability to use the Backup manager feature. This allows any of the client units to become a Backup manager if the manager unit is not communicating.

1. Connect the **Modbus Transmitter** terminal **Pin B** to the **RS485+** terminal, and **Pin A** to the **RS485-** terminal on the I/O Board of any Boiler unit, using shielded pair 18 - 22 AWG cable.
2. Connect the **Header Temp Sensor** to pins **2** and **3** of the **Modbus Transmitter** using shielded pair 18 - 22 AWG cable.
3. Install a jumper wire between pins **1** and **2** of the **Modbus Transmitter**.

#### NOTES:

- Polarity must be observed for the RS485 connections.
- Ground the shield to any **SHLD** terminal on the I/O Board.
- The **Header Temp Sensor** must be installed between 2 and 10 feet (0.61 and 3.1m) downstream of the **last** boiler in the plant's supply water header.
- There is no polarity to be observed. The ground for the shield is at the power supply ground. The sensor end of the shield must be left free and ungrounded.

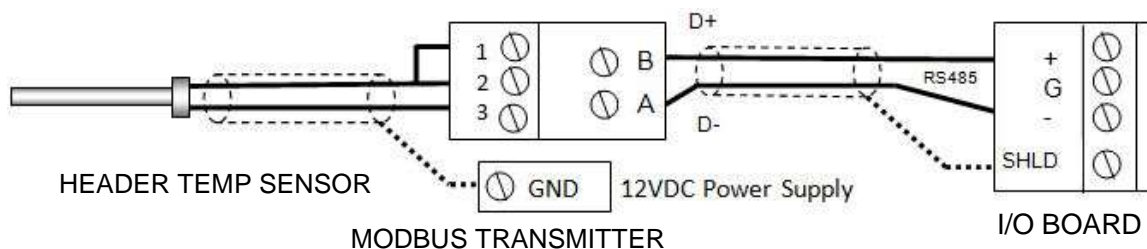

##### Step 2: CONNECT BOILERS IN DAISY CHAIN

1. Connect the boilers in a daisy chain, as shown below.

Continued on next page

SECTION 6: BOILER SEQUENCING TECHNOLOGY

OPTION 2 - Constant Setpoint with Modbus Wired Header Sensor

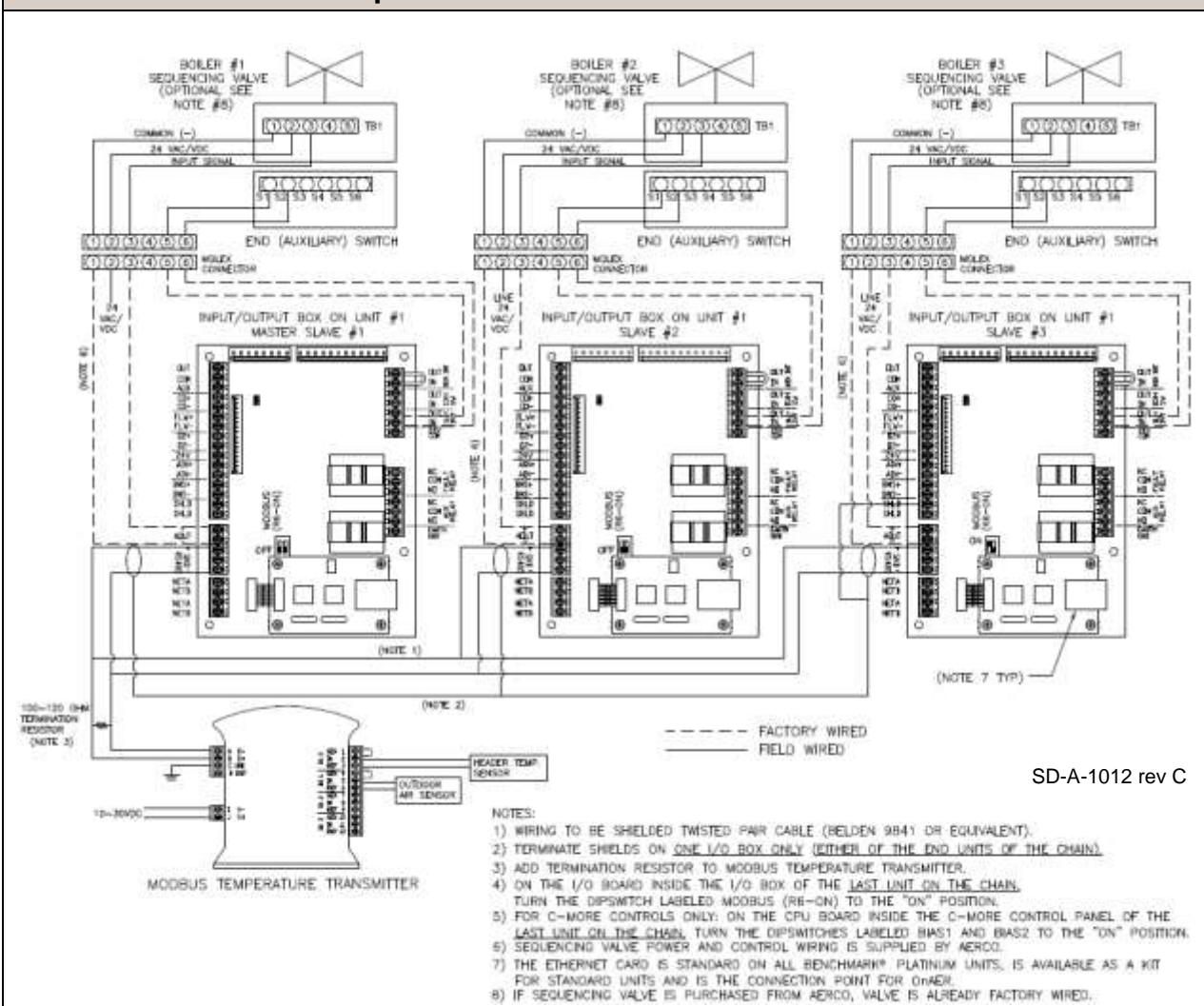

Step 3: Configure ALL C-More Units

On ALL Boilers:

1. Go to the *Configuration* menu and set the BST Menu item to **Enabled**.
2. Go to the Boiler Sequencing Menu and set the BST Mode item to **BST Client** (for now).

On MANAGER only:

3. Go to the BST Setpoint item and enter the desired Setpoint.
4. Go to the BST Setup Menu item and set to **Enabled**.
5. Go to the BST Setpoint Mode item and select **Constant Setpoint**.
6. Go to the Head Temp Source item and select **Network**.
7. Go to the Header Temp Addr item and enter the Modbus Address (240).
8. Go to the Header Temp Point item and enter the Modbus Point (14).

When ALL C-More units have been configured:

9. Go to the Boiler Sequencing Menu of the Manager unit and set the BST Mode item to **BST MANAGER**.

### 6.3.3 OPTION 3 - Outdoor Reset with Direct Wired Header Sensor and Direct Wired Outdoor Sensor

#### OPTION 3 - Outdoor Reset, Direct Wired Header Temp Sensor & Outdoor Sensor

**NOTE:**

Both Header Sensor *and* Outdoor Sensor must be wired. See the *C-More Controller User Manual*, OMM-0032 (GF-112) and *ProtoNode User Manual*, OMM-0080 (GF-129) for more information.

#### Step 1: DIRECT WIRED HEADER TEMP SENSOR WIRING – BST MANAGER Unit

1. On the **BST Manager** unit, connect the **Header Temp Sensor** to the Feed Forward (FFWD) terminals on the P-1 Harness via the terminal block labeled **Header Temp sensor** on the I/O Board.
2. Ground the shield to any **SHLD** terminal on the I/O Board.

**NOTES:**

- The **Header Temp Sensor** must be installed between 2 and 10 feet (0.61 and 3.1m) downstream of the **last** boiler in the plant's supply water header.
- Shielded pair 18 - 22 AWG cable is recommended for **Header Temp Sensor** wiring. There is no polarity to be observed. Ground the shield to the *Shield* terminal on the I/O Board. The sensor end of the shield must be left free and ungrounded.

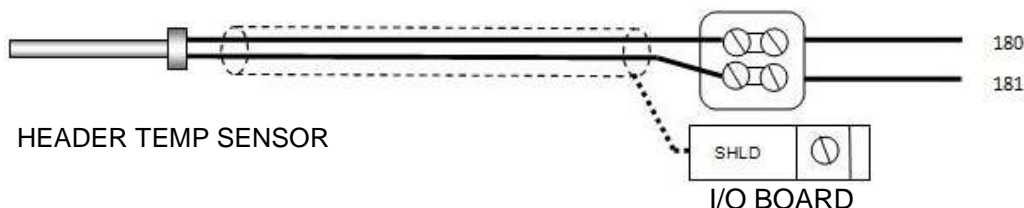

#### Step 2: DIRECT WIRED OUTDOOR SENSOR WIRING – BST MANAGER Unit

1. On the **BST Manager** Unit, connect the **Outdoor Temp Sensor** to the **OUT** and **COM** terminals on the I/O Board.
2. Connect the shield to any **SHLD** terminal on the I/O Board.

**NOTES:**

- Twisted shielded pair 18 - 22 AWG cable is recommended for **Header Temp Sensor** wiring. There is no polarity to be observed. The sensor end of the shield must be left free and ungrounded.
- When mounting the Outdoor sensor, it **must be located on the North side of the building** where an average outside air temperature is expected. The sensor must be shielded from direct sunlight as well as impingement by the elements. The outdoor sensor may be wired up to 200 feet (61m) from the boiler.

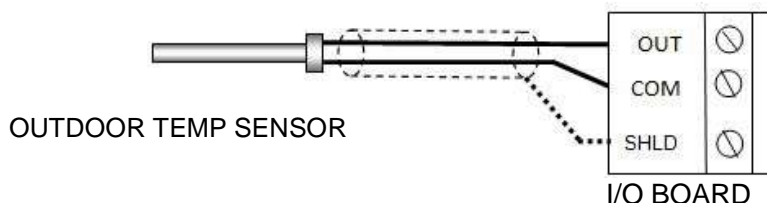

**SECTION 6: BOILER SEQUENCING TECHNOLOGY**

**OPTION 3 - Outdoor Reset, Direct Wired Header Temp Sensor & Outdoor Sensor**

**Step 3 – DAISY CHAIN WIRING BETWEEN BOILERS**

1. Connect the boilers in a daisy chain, as shown below.

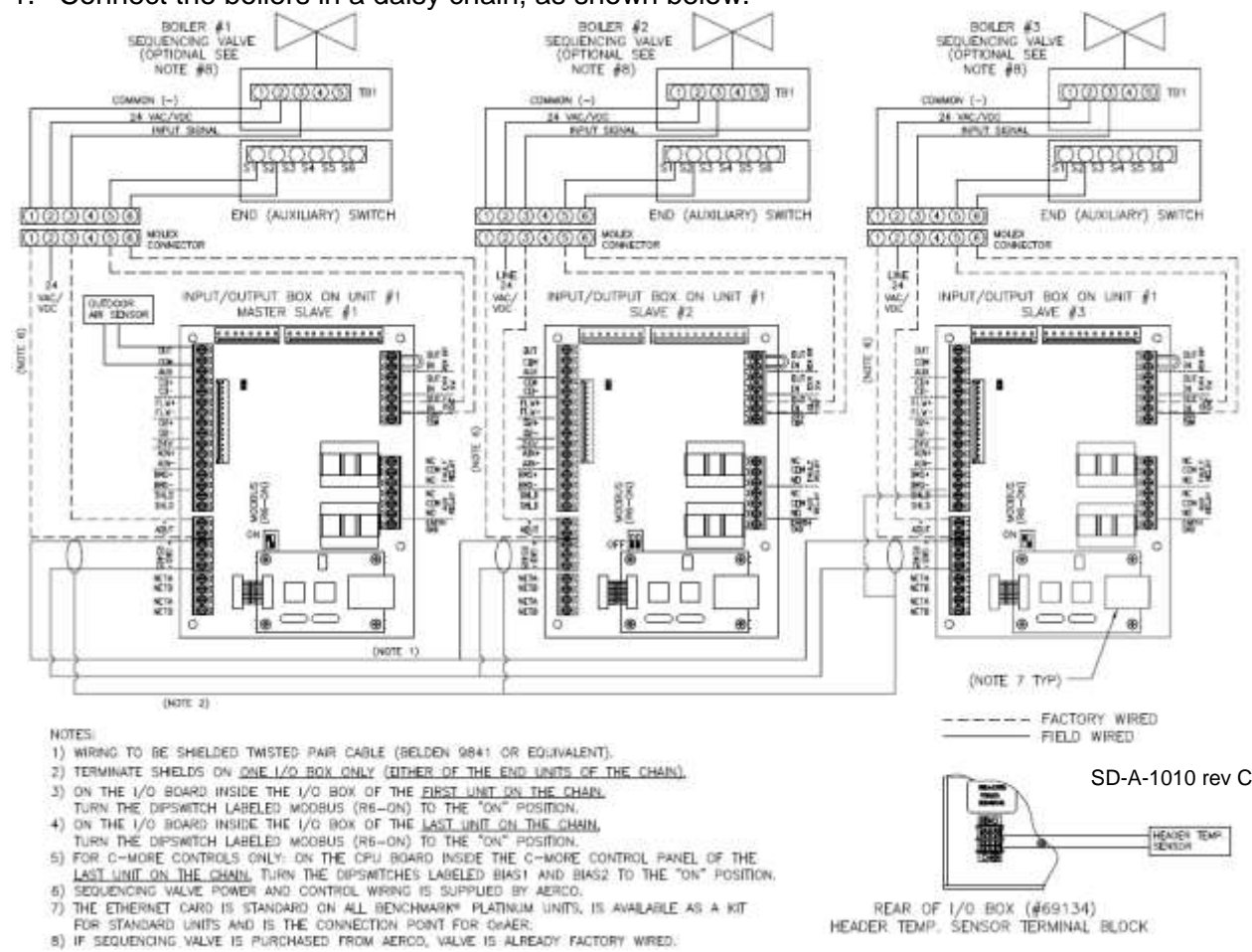

**Step 4 - Configure ALL C-More Units**

**On ALL Boilers:**

1. Go to the *Configuration* menu and set the BST Menu item to **Enabled**.
2. Go to the Boiler Sequencing Menu and set the BST Mode item to **BST Client** (for now).

**On MANAGER only:**

3. Go to the BST Setpoint item and enter the Failsafe Setpoint.
4. Go to the BST Setup Menu item and set to **Enabled**.
5. Go to the BST Setpoint Mode item and select **Outdoor Reset**.
6. Go to the Head Temp Source item and select **FFWD Temp**.
7. Go to the BST Outdoor Sens item and select **Enabled**.
8. Go to the Outdoor Temp Source item and select **Outdoor Temp**.

**When ALL C-More units have been configured:**

9. Go to the Boiler Sequencing Menu of the Manager unit and set the BST Mode item to **BST MANAGER**.

### 6.3.4 OPTION 4 - Outdoor Reset with Modbus Header Sensor and Modbus Outdoor Sensor

#### OPTION 4 - Outdoor Reset with Modbus Header Sensor and Modbus Outdoor Sensor Instructions

**NOTE:**

Both Header Sensor AND Outdoor Sensor must be wired. See the *C-More Controller User Manual*, OMM-0032 (GF-112) and *ProtoNode User Manual*, OMM-0080 (GF-129) for more information.

#### Step 1: HEADER TEMP SENSOR WIRING – ANY BOILER

Using the **Modbus Transmitter** gives the plant the ability to use the **Backup manager** feature. This allows any of the client units to become a **Backup manager** if the manager unit is not communicating.

1. Connect the **Modbus Transmitter** terminal **Pin B** to the **RS485+** terminal, and **Pin A** to the **RS485-** terminal on the I/O Board of any Boiler unit, using shielded pair 18 - 22 AWG cable.
2. Connect the **Header Temp Sensor** (P/N 61040) to pins **2** and **3** of the **Modbus Transmitter**, using shielded pair 18 - 22 AWG cable.
3. Install a jumper wire between pins **1** and **2** of the **Modbus Transmitter**.

**NOTES:**

- Polarity must be observed for the RS485 connections.
- Ground the shield to any **SHLD** terminal on the I/O Board.
- The **Header Temp Sensor** must be installed between 2 and 10 feet (0.61 and 3.1m) downstream of the **last** boiler in the plant's supply water header.
- There is no polarity to be observed. The ground for the shield is at the power supply ground. The sensor end of the shield must be left free and ungrounded.

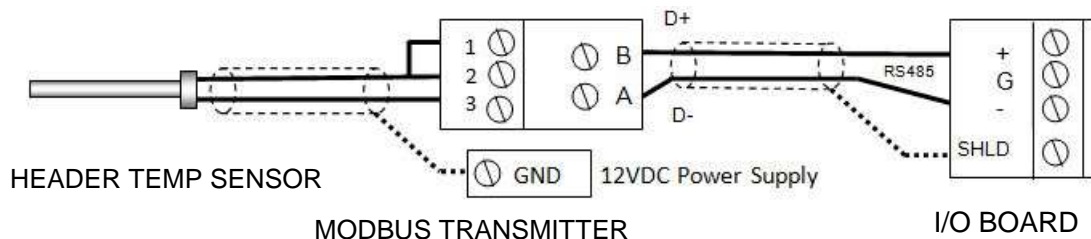

#### Step 2: OUTDOOR SENSOR WIRING

1. If you have not already done so, complete step 1 of the instructions above to connect the **Modbus Transmitter** to the I/O Board.
2. Connect the **Outdoor Temp Sensor** to **Pins 5** and **6** of the **Modbus Transmitter** using a shielded pair 18 - 22 AWG cable.
3. On the **Modbus Transmitter**, install a jumper wire between **Pins 4** and **5**.

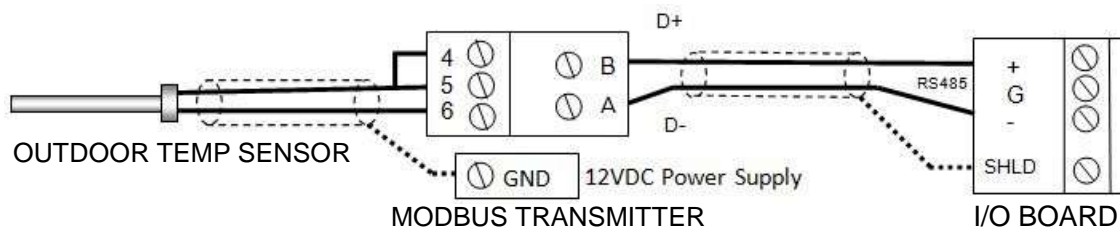

SECTION 6: BOILER SEQUENCING TECHNOLOGY

**OPTION 4 - Outdoor Reset with Modbus Header Sensor and Modbus Outdoor Sensor Instructions**

**NOTES:**

- Polarity must be observed for the RS485 connections.
- Ground the shield at any **SHLD** terminal in the I/O the Board.
- When mounting the Outdoor sensor, it must be located on the North side of the building where an average outside air temperature is expected. The sensor must be shielded from direct sunlight as well as impingement by the elements. The outdoor sensor may be wired up to 200 feet (61m) from the boiler.
- There is no polarity to be observed. The ground for the shield is at the power supply ground. The sensor end of the shield must be left free and ungrounded.

**Step 3 – DAISY CHAIN WIRING BETWEEN BOILERS**

1. Connect the boilers in a daisy chain, as shown below.

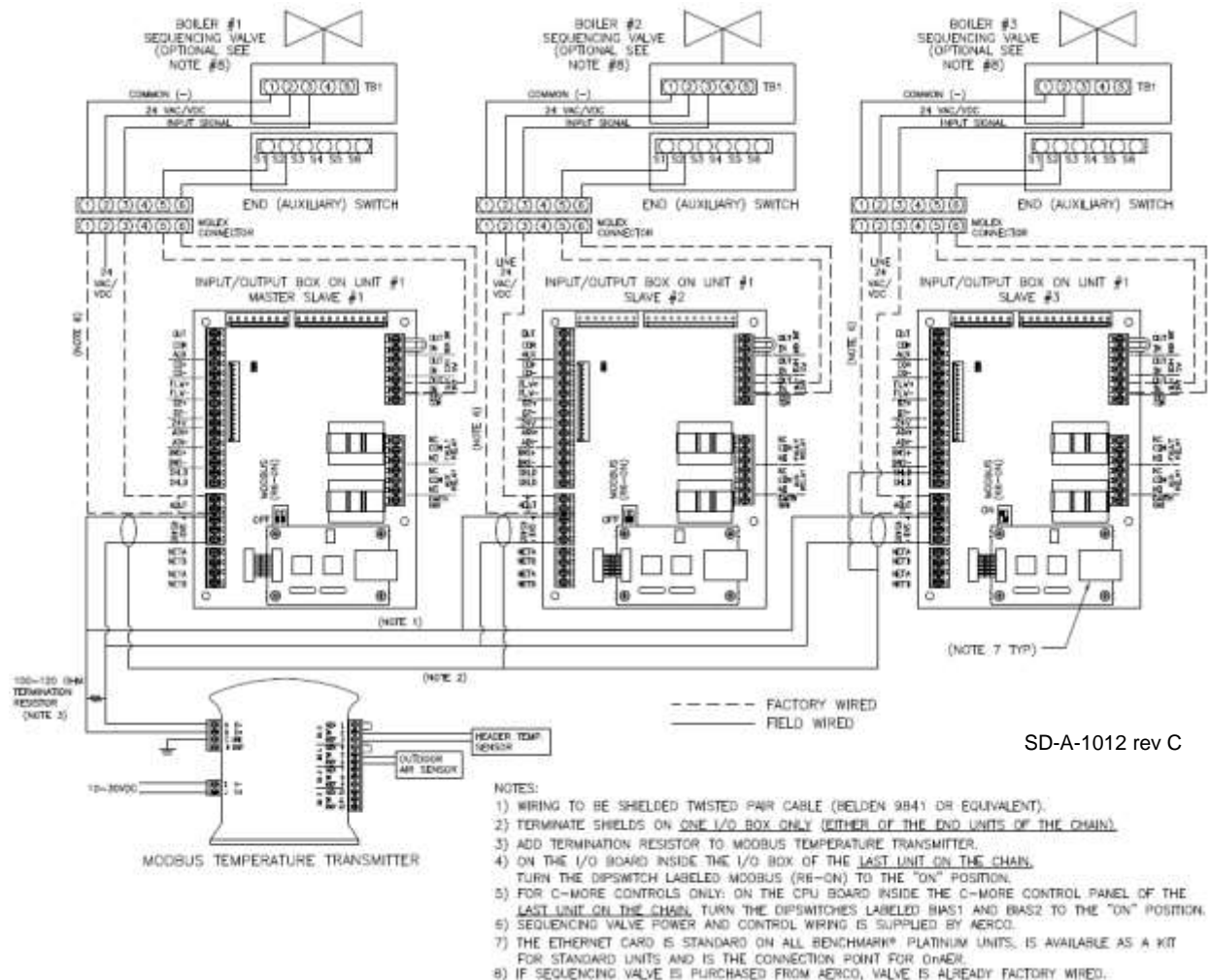

Continued on next page

**OPTION 4 - Outdoor Reset with Modbus Header Sensor and Modbus Outdoor Sensor Instructions****Step 4 - Configure ALL C-More Units****On ALL Boilers:**

1. Go to the *Configuration* menu and set the BST Menu item to **Enabled**.
2. Go to the Boiler Sequencing Menu and set the BST Mode item to **BST Client** (for now).

**On MANAGER only:**

3. Go to the BST Setpoint item and enter the Failsafe Setpoint.
4. Go to the BST Setup Menu item and set to **Enabled**.
5. Go to the BST Setpoint Mode item and select **Outdoor Reset**.
6. Go to the Head Temp Source item and select **Network**.
7. Go to the Header Temp Addr item and enter the Modbus Address (240).
8. Go to the Header Temp Point item and enter the Modbus Point (14).
9. Go to the BST Outdoor Sens item and select **Enabled**.
10. Go to the Outdoor Temp Source item and select **Network**.
11. Go to the Outdoor Temp Addr item and enter the Modbus Address (240).
12. Go to the Outdoor Temp Point item and enter the Modbus Point (15).

**When ALL C-More units have been configured:**

13. Go to the Boiler Sequencing Menu of the Manager unit and set the BST Mode item to **BST MANAGER**.

### 6.3.5 OPTION 5 - Remote Setpoint with Direct Wired Header Sensor and 4-20ma Setpoint Drive

#### OPTION 5 - Remote Setpoint with Direct Wired Header Sensor and 4-20ma Setpoint Drive Instructions

**NOTE:**

Both Header Sensor AND 4-20ma Direct Drive must be wired. See the *C-More Controller User Manual*, OMM-0032 (GF-112) and *ProtoNode User Manual*, OMM-0080 (GF-129) for more information.

#### Step 1: HEADER TEMP SENSOR WIRING – BST MANAGER Unit

1. On the **BST Manager** unit, connect the **Header Temp Sensor** to the **Feed Forward (FFWD)** terminals on the P-1 Harness via the terminal block labeled **Header Temp sensor** on the I/O Board.
2. Ground the shield to any **SHLD** terminal on the I/O Board.

**NOTES:**

- The **Header Temp Sensor** must be installed between 2 and 10 feet (0.61 and 3.1m) downstream of the **last** boiler in the plant's supply water header.
- Shielded pair 18 - 22 AWG cable is recommended for **Header Temp Sensor** wiring. There is no polarity to be observed. The ground for the shield is at the **SHLD** terminal on the I/O Board. The sensor end of the shield must be left free and ungrounded.

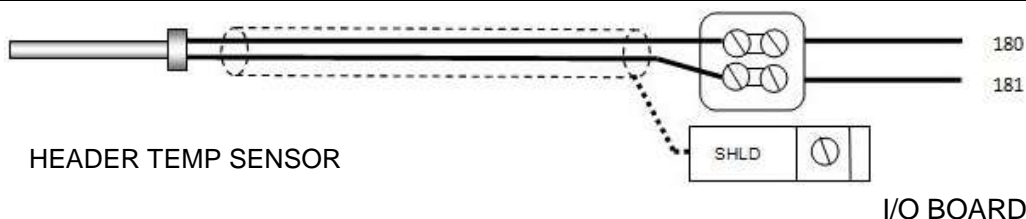

#### Step 2: DIRECT WIRED 0-20mA or 4-20mA WIRING – BST MANAGER Unit

1. Connect the **4-20mA** or **0-20mA** terminals from the Direct Drive source to the **Ain+** and **Ain-** terminals on the BST Manager's I/O Board.
2. Connect the shield to any **SHLD** terminal on the I/O Board.

**NOTES:**

- Shielded pair 18 - 22 AWG cable is recommended for this connection. Polarity must be observed.
- The ground for the shield is at the driver signal source.

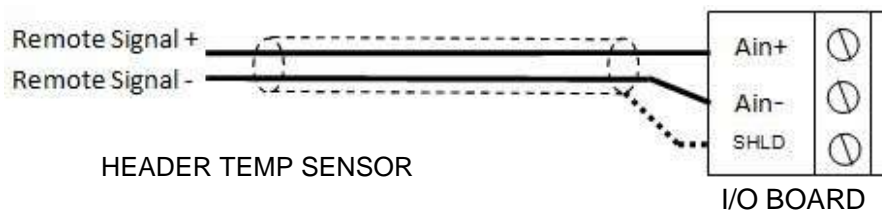



SECTION 6: BOILER SEQUENCING TECHNOLOGY

**OPTION 5 - Remote Setpoint with Direct Wired Header Sensor and 4-20ma Setpoint Drive Instructions**

**Step 3 – DAISY CHAIN WIRING BETWEEN BOILERS**

1. Connect the boilers in a daisy chain, as shown below.

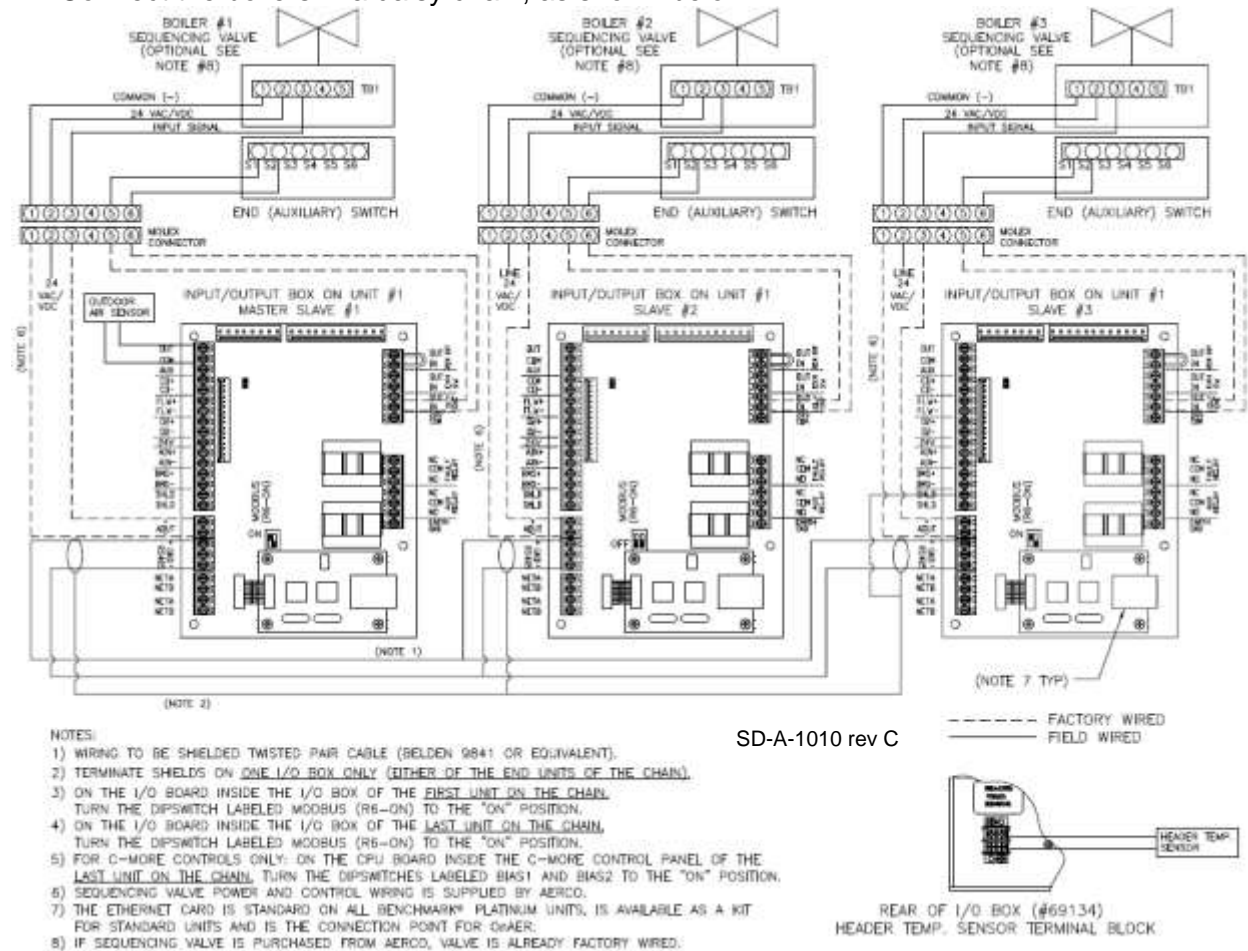

**Step 4: Configure ALL C-More Units**

**On ALL Boilers:**

1. Go to the *Configuration* menu and set the BST Menu item to **Enabled**.
2. Go to the Boiler Sequencing Menu and set the BST Mode item to **BST Client** (for now).

**On MANAGER only:**

3. Go to the BST Setpoint item and enter the Failsafe Setpoint.
4. Go to the BST Setup Menu item and set to **Enabled**.
5. Go to the BST Setpoint Mode item and select **Remote Setpoint**.
6. Go to the Head Temp Source item and select **FFWD Temp**.
7. Go to the BST Remote Signal and select either **4-20ma** or **0-20ma**.

**When ALL C-More units have been configured:**

8. Go to the Boiler Sequencing Menu of the Manager unit and set the BST Mode item to **BST MANAGER**.

### 6.3.6 OPTION 6 - Remote Setpoint with Direct Wired Header Sensor and Modbus Setpoint Drive

#### OPTION 6 - Remote Setpoint with Direct Wired Header Sensor and Modbus Setpoint Drive Instructions

##### NOTE:

Both Header Sensor AND Outdoor Sensor must be wired. See the *C-More Controller User Manual*, OMM-0032 (GF-112) and *ProtoNode User Manual*, OMM-0080 (GF-129) for more information.

#### Step 1: HEADER TEMP SENSOR WIRING – BST MANAGER Unit

1. On the **BST Manager** unit, connect the **Header Temp Sensor** to the **Feed Forward (FFWD)** terminals on the P-1 Harness via the terminal block labeled **Header Temp sensor** on the I/O Board.
2. Ground the shield to any **SHLD** terminal on the I/O Board.

##### NOTES:

- The **Header Temp Sensor** must be installed between 2 and 10 feet (0.61 and 3.1m) downstream of the **last** boiler in the plant's supply water header.
- Shielded pair 18 - 22 AWG cable is recommended for **Header Temp Sensor** wiring. There is no polarity to be observed. The ground for the shield is at the **SHLD** terminal on the I/O Board. The sensor end of the shield must be left free and ungrounded.

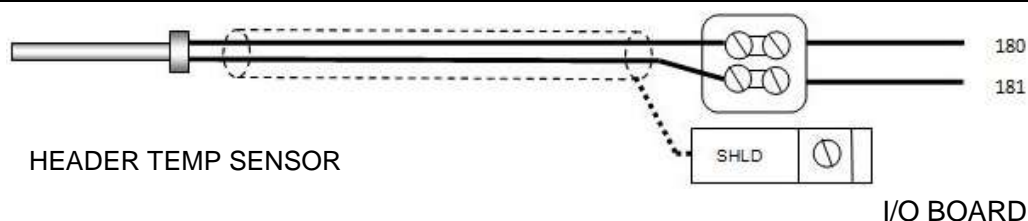

#### Step 2: CONFIGURE AND CONNECT SSD DEVICE (PROTONODE)

1. Connect the ProtoNode per the instructions in one of the *ProtoNode FPC N34, FPC-N35 Manuals*:
  - For FPC-N34 (P/N 64129) or FPC-N35 (P/N 64130), see OMM-0107 (GF-150).
  - For FPC-N34 (P/N 64168) or FPC-N35 (P/N 64169), see OMM-0150 (GF-150\_B).

Continued on next page

**SECTION 6: BOILER SEQUENCING TECHNOLOGY**

**OPTION 6 - Remote Setpoint with Direct Wired Header Sensor and Modbus Setpoint Drive Instructions**

**Step 3 – DAISY CHAIN WIRING BETWEEN BOILERS**

1. Connect the boilers in a daisy chain, as shown below.

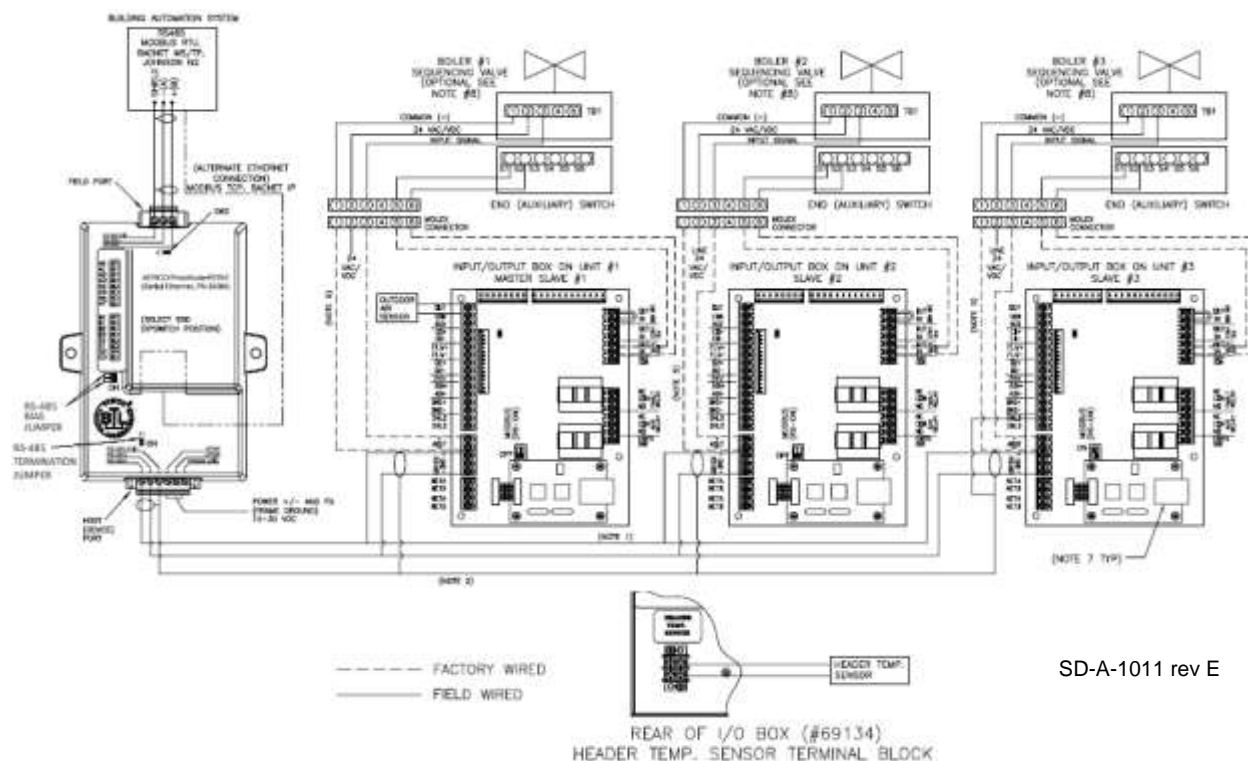

SD-A-1011 rev E

**NOTES:**

- 1) WIRING TO BE SHIELDED TWISTED PAIR CABLE (BELDEN 9841 OR EQUIVALENT).
- 2) TERMINATE SHIELDS ON ONE I/O BOX ONLY (EITHER OF THE END UNITS OF THE CHAIN).
- 3) REMOVE COVER FROM PROTONODE AND PLACE RED "BIAS" JUMPERS IN THE "ON" POSITION AND THE BLUE "TERMINATION" JUMPER IN THE "ON" POSITION.
- 4) ON THE I/O BOARD INSIDE THE I/O BOX OF THE LAST UNIT ON THE CHAIN, TURN THE DIPSWITCH LABELED MODBUS (R6-ON) TO THE "ON" POSITION.
- 5) SEQUENCING VALVE POWER AND CONTROL WIRING IS SUPPLIED BY AERCO.
- 6) IF TERMINATION IS NEEDED AT FIELD PORT CONNECTION TO THE BUILDING AUTOMATION SYSTEM (BAS), ACTIVATE THE "END OF LINE" TERMINATION SWITCH (SW2) JUST BELOW THE FIELD PORT UNDER THE COVER. SEE GF-129 MANUAL FOR MORE DETAILED INFORMATION ON THE PROTONODE.
- 7) THE ETHERNET CARD IS STANDARD ON ALL BENCHMARK® PLATINUM UNITS, IS AVAILABLE AS A KIT FOR STANDARD UNITS AND IS THE CONNECTION POINT FOR OnAER.
- 8) IF SEQUENCING VALVE IS PURCHASED FROM AERCO, VALVE IS ALREADY FACTORY WIRED.

**NOTES:**

- Polarity must be observed for the RS485 connections.
- Connect the shield to any **SHLD** terminal on the I/O Board.
- When mounting the **Outdoor Temp Sensor**, it must be located on the North side of the building where an average outside air temperature is expected. The sensor must be shielded from direct sunlight as well as impingement by the elements. The outdoor sensor may be wired up to 200 feet (61m) from the boiler.
- There is no polarity to be observed. The ground for the shield is at the power supply ground. The sensor end of the shield must be left free and ungrounded.

**Continued on next page**

**OPTION 6 - Remote Setpoint with Direct Wired Header Sensor and Modbus Setpoint Drive Instructions****Step 4 - Configure ALL C-More Units****On ALL Boilers:**

1. Go to the *Configuration* menu and set the BST Menu item to **Enabled**.
2. Go to the Boiler Sequencing Menu and set the BST Mode item to **BST Client** (for now).

**On MANAGER only:**

3. Go to the BST Setpoint item and enter the Failsafe Setpoint.
4. Go to the BST Setup Menu item and set to **Enabled**.
5. Go to the BST Setpoint Mode item and select Outdoor Reset.
6. Go to the Head Temp Source item and select **Network**.
7. Go to the Header Temp Addr item and enter the Modbus Address (240).
8. Go to the Header Temp Point item and enter the Modbus Point (14).
9. Go to the BST Outdoor Sens item and select **Enabled**.
10. Go to the Outdoor Temp Source item and select **Network**.
11. Go to the Outdoor Temp Addr item and enter the Modbus Address (240).
12. Go to the Outdoor Temp Point item and enter the Modbus Point (15).

**When ALL C-More units have been configured:**

13. Go to the Boiler Sequencing Menu item of the Manager unit and set the BST Mode item to **BST MANAGER**.

### 6.3.7 OPTION 7 - Remote Setpoint with Modbus Header Sensor and 4-20ma Setpoint Drive

#### OPTION 7 - Remote Setpoint with Modbus Header Sensor and 4-20ma Setpoint Drive Instructions

**NOTE:**

Both Header Sensor AND 4-20ma Direct Drive must be wired. See the *C-More Controller User Manual*, OMM-0032 (GF-112) and *ProtoNode User Manual*, OMM-0080 (GF-129) for more information.

#### Step 1: MODBUS HEADER TEMP SENSOR WIRING – ANY BOILER

1. Connect the **Modbus Transmitter** terminal **Pin B** to the **RS485+** terminal, and **Pin A** to the **RS485-** terminal on the I/O Board of any Boiler unit, using shielded pair 18 - 22 AWG cable.
2. Connect the shield to any **SHLD** terminal on the I/O Board.
3. Connect the **Header Temp Sensor** to pins **2** and **3** of the **Modbus Transmitter** units using Shielded pair 18 - 22 AWG cable.
4. On the **Modbus Transmitter**, install a jumper wire between pins 1 and 2.

**NOTES:**

- Polarity must be observed for the RS485 connections.
- Connect the shield to any **SHLD** terminal on the I/O Board.
- The **Header Temp Sensor** must be installed between 2 and 10 feet (0.61 and 3.1m) downstream of the **last** boiler in the plant's supply water header.
- There is no polarity to be observed. The ground for the shield is at the power supply ground. The sensor end of the shield must be left free and ungrounded.

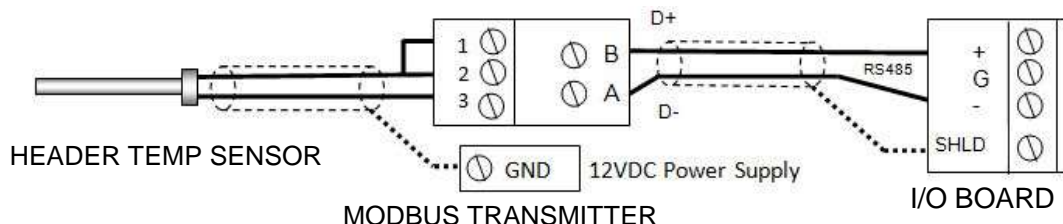

#### Step 2: DIRECT WIRED 0-20mA or 4-20mA WIRING – BST MANAGER

1. Connect the **4-20mA** or **0-20mA** terminals from the Direct Drive source to the **Ain+** and **Ain-** terminals on the BST Manager.
2. Connect the shield to any **SHLD** terminal on the I/O Board.

**NOTES:**

- Shielded pair 18 - 22 AWG cable is recommended for this connection. Polarity must be observed.
- The ground for the shield is at the driver signal source.



SECTION 6: BOILER SEQUENCING TECHNOLOGY

**OPTION 7 - Remote Setpoint with Modbus Header Sensor and 4-20ma Setpoint Drive Instructions**

**Step 3: CONNECT BOILERS IN DAISY CHAIN**

1. Connect the boilers in a daisy chain, as shown below.

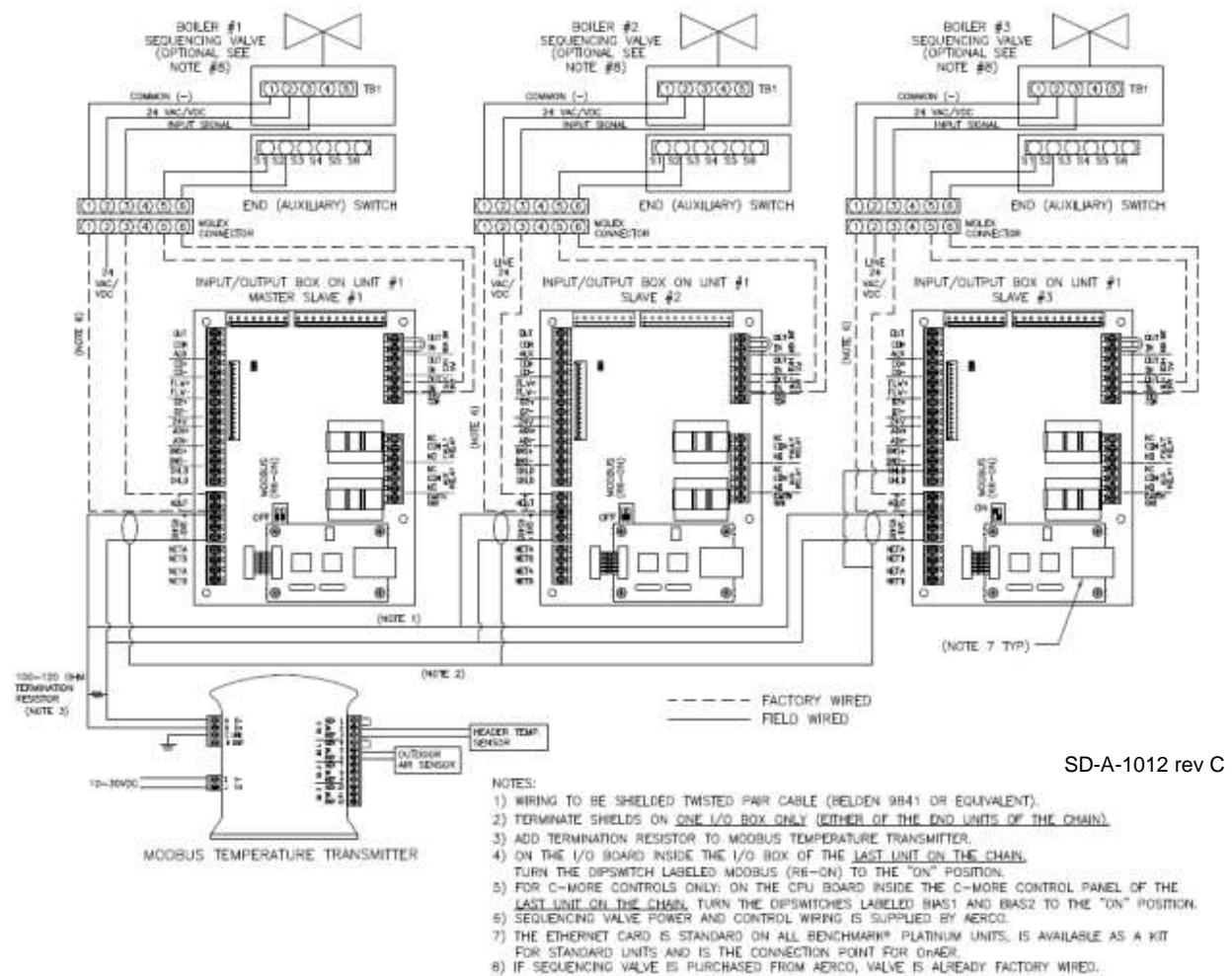

SD-A-1012 rev C

**Step 4: Configure ALL C-More Units**

**On ALL Boilers:**

1. Go to the *Configuration* menu and set the BST Menu item to **Enabled**.
2. Go to the Boiler Sequencing Menu and set the BST Mode item to **BST Client** (for now).

**On MANAGER only:**

3. Go to the BST Setpoint item and enter the Failsafe Setpoint.
4. Go to the BST Setup Menu item and set to **Enabled**.
5. Go to the BST Setpoint Mode item and select **Remote Setpoint**.
6. Go to the BST Remote Signal and select either 4-20ma or 0-20ma.
7. Go to the Head Temp Source item and select **Network**.
8. Go to the Header Temp Addr item and enter the Modbus Address (240).
9. Go to the Header Temp Point item and enter the Modbus Point (14).

**When ALL C-More units have been configured:**

10. Go to the Boiler Sequencing Menu of the Manager unit and set the BST Mode item to **BST MANAGER**.

### 6.3.8 OPTION 8 - Remote Setpoint with Modbus Header Sensor and Modbus Setpoint Drive

#### OPTION 8 - Remote Setpoint with Modbus Header Sensor and Modbus Setpoint Drive Instructions

##### NOTE:

Both Header Sensor AND ProtoNode SSD Device must be wired. See the *C-More Controller User Manual*, OMM-0032 (GF-112) and *ProtoNode User Manual*, OMM-0080 (GF-129) for more information.

#### Step 1: MODBUS HEADER TEMP SENSOR WIRING – ANY BOILER

1. Connect the **Modbus Transmitter** terminal **Pin B** to the **RS485+** terminal, and **Pin A** to the **RS485-** terminal on the I/O Board of any Boiler unit, using shielded pair 18 - 22 AWG cable.
2. Connect the shield to any **SHLD** terminal on the I/O Board.
3. Connect the **Header Temp Sensor** to pins **2** and **3** of the **Modbus Transmitter** using shielded pair 18 - 22 AWG cable.
4. Install a jumper wire between pins 1 and 2 of the **Modbus Transmitter**.

##### NOTES:

- Polarity must be observed for the RS485 connections.
- Connect the shield to any **SHLD** terminal on the I/O Board.
- The **Header Temp Sensor** must be installed between 2 and 10 feet (0.61 and 3.1m) downstream of the **last** boiler in the plant's supply water header.
- There is no polarity to be observed. The ground for the shield is at the power supply ground. The sensor end of the shield must be left free and ungrounded.

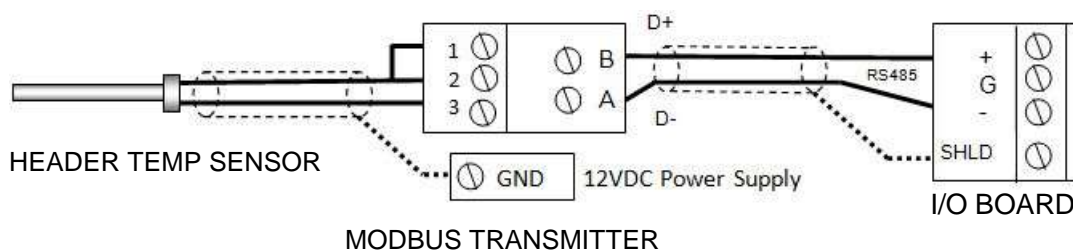

#### Step 2: CONFIGURE AND CONNECT SSD DEVICE (PROTONODE)

1. Connect the ProtoNode per the instructions in one of the *ProtoNode FPC N34, FPC-N35 Manuals*:
  - For FPC-N34 (P/N 64129) or FPC-N35 (P/N 64130), see OMM-0107 (GF-150).
  - For FPC-N34 (P/N 64168) or FPC-N35 (P/N 64169), see OMM-0150 (GF-150\_B).

#### Step 3: CONNECT BOILERS IN DAISY CHAIN

1. Connect the boilers in a daisy chain, as shown below.

Continued on next page

**OPTION 8 - Remote Setpoint with Modbus Header Sensor and Modbus Setpoint Drive Instructions**

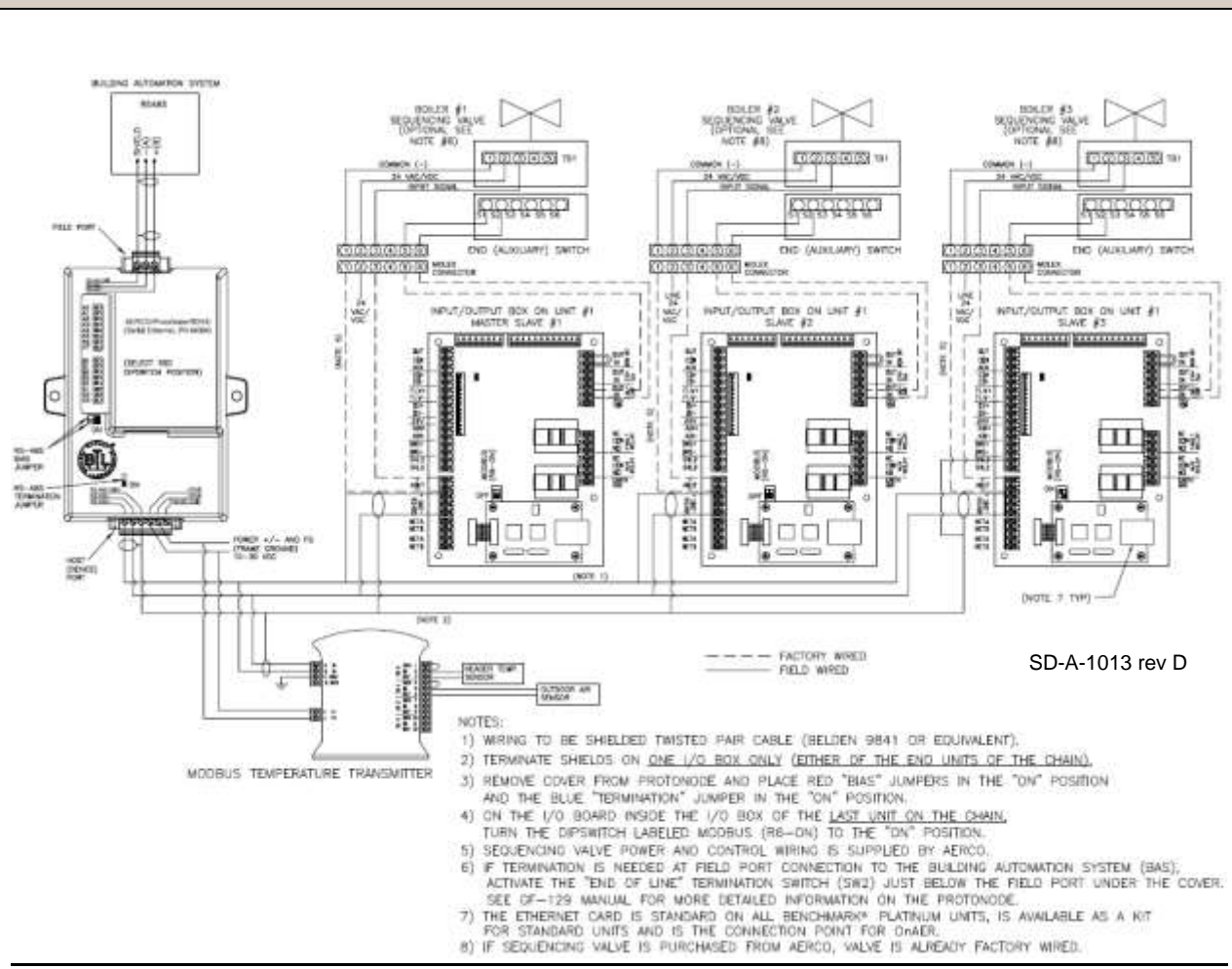

**Step 4: Configure ALL C-More Units**

**On ALL Boilers:**

1. Go to the *Configuration* menu and set the BST Menu item to **Enabled**.
2. Go to the Boiler Sequencing Menu and set the BST Mode item to **BST Client** (for now).

**On MANAGER only:**

3. Go to the BST Setpoint item and enter the failsafe Setpoint.
4. Go to the BST Setup Menu item and set to **Enabled**.
5. Go to the BST Setpoint Mode item and select **Remote Setpoint**.
6. Go to the BST Remote Signal and select either Network.
7. Go to the Header Temp Source item and select **Network**.
8. Go to the Header Temp Addr item and enter the Modbus Address (240).
9. Go to the Header Temp Point item and enter the Modbus Point (14).

**When ALL C-More units have been configured:**

10. Go to the Boiler Sequencing Menu of the Manager unit and set the BST Mode item to **BST MANAGER**.



Appendix A: Dimensional and Clearance Drawings

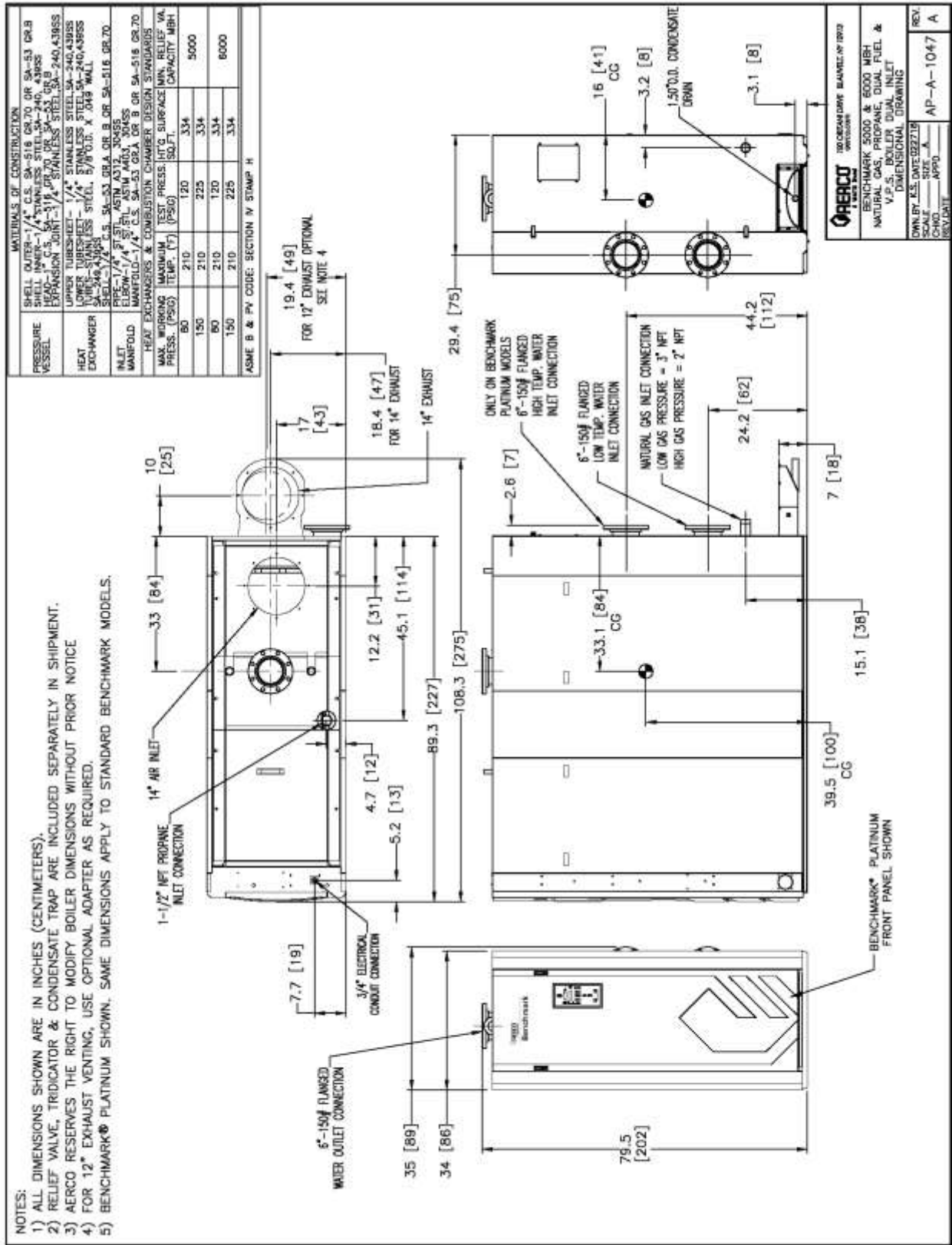

Drawing Number: AP-A-1047 rev A

APPENDIX A: DIMENSIONAL AND CLEARANCE DRAWINGS

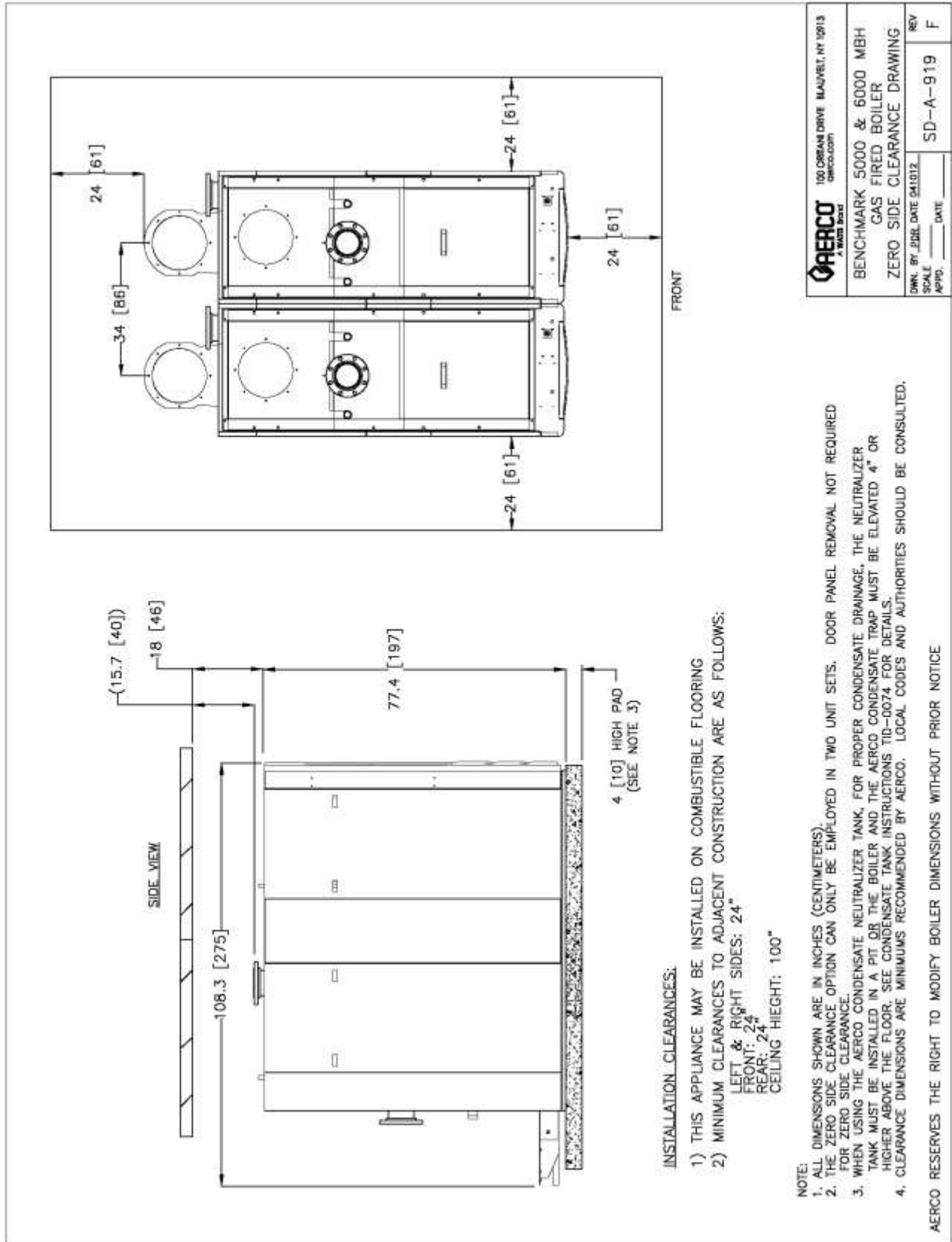

Drawing Number: SD-A-919 rev F

---

**NOTES:**

**Change Log:**

Date	Description	Changed By
12/19/2019	<p><b>Rev E:</b>                      Added manifold pressure values for Low Gas Pressure (LGP) gas trains to Natural Gas Combustion Calibration Table 4-1, page 52.</p>	Linley Thobourne
5/25/2020	<p><b>Rev F:</b>                      Additions to cover Low Gas Pressure (LGP) models, in Sections 2.4, 2.9.3, 3.4, 4.2.2 and 4.3.                      Minor correction to Low Gas Pressure Test, Section 5.2.                      Revised BST setup instructions, Sections 6.3.1 – 6.3.8</p>	Chris Blair