

Operation and Service Manual



Benchmark® Platinum Boilers

Natural Gas, Propane Gas and Dual Fuel
Modulating & Condensing Boilers

Models 750 through 3000



Other documents for this product include:

- OMM-0115, GF-200 210 Installation and Startup Manual
- TAG-0019, GF-2070 Boiler Application Guide
- TAG-0022, GF-2050 Vent-Combustion Air Guide
- TAG-0047, GF-2030 Benchmark Gas Guide
- TAG-0048, GF-2060 Benchmark Power Guide

Applies to serial numbers:

G-19-0001 and above – BMK 750 – 3000

Disclaimer

The information contained in this manual is subject to change without notice from AERCO International, Inc. AERCO makes no warranty of any kind with respect to this material, including, but not limited to, implied warranties of merchantability and fitness for a particular application. AERCO International is not liable for errors appearing in this manual, not for incidental or consequential damages occurring in connection with the furnishing, performance, or use of these materials

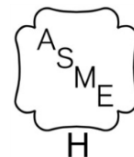

Heating and Hot Water Solutions

TABLE OF CONTENTS

FOREWORD	5
SECTION 1: SAFETY PRECAUTIONS	9
1.1 WARNINGS & CAUTIONS	9
1.2 EMERGENCY SHUTDOWN.....	10
1.3 PROLONGED SHUTDOWN.....	10
1.4 IMPORTANT – FOR MASSACHUSETTS INSTALLATIONS	11
SECTION 2: OPERATION	13
2.1 INTRODUCTION.....	13
2.2 C-MORE CONTROLLER DESCRIPTION	14
2.3 C-MORE CONTROLLER MENUS.....	17
2.3.1 Menu Navigation and Processing Procedure.....	17
2.4 OPERATING MENU	19
2.5 SETUP MENU.....	20
2.6 CONFIGURATION MENU	21
2.7 TUNING MENU.....	23
2.8 COMBUSTION CAL MENU	23
2.8.1 BMK 750/1000 COMBUSTION CAL Menu	23
2.8.2 BMK 1500/2000 COMBUSTION CAL Menus	24
2.8.3 BMK 2500/3000 COMBUSTION CAL Menus	25
2.9 BST (BOILER SEQUENCING TECHNOLOGY) MENU	26
2.10 CALIBRATION MENU.....	29
SECTION 3: MODES OF OPERATION	31
3.1 INTRODUCTION.....	31
3.2 INDOOR/OUTDOOR RESET MODE	31
3.2.1 Reset Ratio.....	31
3.2.2 Building Reference Temperature.....	31
3.2.3 Outdoor Air Temperature Sensor Installation	31
3.2.4 Indoor/Outdoor Startup	32
3.3 CONSTANT SETPOINT MODE	32
3.3.1 Setting the Setpoint.....	33
3.4 REMOTE SETPOINT MODES	33
3.4.1 Remote Setpoint Field Wiring.....	34
3.4.2 Remote Setpoint Startup	34
3.5 DIRECT DRIVE MODES.....	34
3.5.1 Direct Drive Field Wiring.....	35
3.5.2 Direct Drive Startup	35
3.6 AERCO CONTROL SYSTEM (ACS)	36
3.6.1 ACS External Field Wiring.....	36
3.6.2 ACS Setup and Startup.....	36
3.7 COMBINATION CONTROL SYSTEM (CCS)	37
3.7.1 Combination Control System Field Wiring.....	38
3.7.2 Combination Control System Setup and Startup.....	38
SECTION 4: MAINTENANCE	39
4.1 MAINTENANCE SCHEDULE	39
4.2 IGNITER-INJECTOR	40

CONTENTS

4.3 FLAME DETECTOR	45
4.4 O ₂ SENSOR	45
4.5 SAFETY DEVICE TESTING	46
4.6 BURNER INSPECTION	46
4.6.1 BMK 750/1000 BURNER INSPECTION	47
4.6.2 BMK 1500 – 3000 BURNER INSPECTION	49
4.7 CONDENSATE DRAIN TRAP	53
4.8 AIR FILTER CLEANING AND REPLACEMENT	54
4.9 WATER CUTOFF (LWCO) CAPACITOR INTEGRITY TEST	55
4.9.1 Low Water Cutoff (LWCO) - Capacitor Electrical Short Test	56
4.9.2 Low Water Cutoff (LWCO) - Standard C-More Test	57
4.10 SHUTTING BOILER DOWN FOR EXTENDED PERIOD	57
4.11 PLACING THE BOILER BACK IN SERVICE AFTER A PROLONGED SHUTDOWN	58
4.12 SPARK MONITOR (AC CURRENT TRANSDUCER)	58
SECTION 5: TROUBLESHOOTING GUIDE	59
5.1 INTRODUCTION	59
5.2 ADDITIONAL FAULTS WITHOUT SPECIFIC FAULT MESSAGES	71
SECTION 6: AERTRIM OPERATION	73
6.1 AERTRIM INTRODUCTION	73
6.2 AERTRIM ACTIVATION	74
6.3 OPERATION DETAILS	75
6.4 AERTRIM AUTO CALIBRATION	76
6.5 AERTRIM MENU ITEMS	78
6.6 AERTRIM MENU VALUES AND DEFAULTS	79
6.7 AERTRIM MAINTENANCE AND TROUBLESHOOTING	85
APPENDIX A: BOILER MENU ITEM DESCRIPTIONS	88
TABLE A-1: OPERATING MENU ITEM DESCRIPTIONS	88
TABLE A-2: SETUP MENU ITEM DESCRIPTIONS	90
TABLE A-3: CONFIGURATION MENU ITEM DESCRIPTIONS	91
TABLE A-4: TUNING MENU ITEM DESCRIPTIONS	94
TABLE A-5: COMBUSTION CALIBRATION MENU ITEM DESCRIPTIONS	95
TABLE A-6: CALIBRATION MENU ITEM DESCRIPTIONS	96
APPENDIX B: STARTUP, STATUS, & FAULT MESSAGES	100
APPENDIX B-1: STARTUP AND STATUS MESSAGES	100
APPENDIX B-2: FAULT MESSAGES	101
APPENDIX C: SENSOR RESISTANCE/VOLTAGE CHART	104
APPENDIX D: RECOMMENDED PERIODIC TESTING	106
APPENDIX E: INDOOR/OUTDOOR RESET RATIO CHARTS	108
APPENDIX F: BENCHMARK PLATINUM 750/1000 PART LISTS	112
APPENDIX G: BENCHMARK PLATINUM 1500/2000 PART LISTS	122
APPENDIX H: BENCHMARK PLATINUM 2500/3000 PART LISTS	138

CONTENTS

APPENDIX I: WIRING DIAGRAMS 160

APPENDIX J: C-MORE CONTROLLER VIEWS 176

APPENDIX K: RECOMMENDED SPARES 178

FOREWORD

The AERCO Benchmark (BMK) 750, 1000, 1500, 2000, 2500, and 3000 natural gas and propane fueled boilers are modulating and condensing units. They represent a true industry advance that meets the needs of today's energy and environmental concerns. Designed for application in any closed loop hydronic system, the Benchmark's modulating capability relates energy input directly to fluctuating system loads. These BMK models provide extremely high efficiency operation and are ideally suited for modern low temperature, as well as, conventional heating systems.

The Benchmark models operate within the following input and output ranges:

IMPORTANT!

Unless otherwise specified:

- all descriptions provided in this document apply to the Benchmark Platinum Series of boiler.
- all measurements apply to both natural gas and propane models, unless otherwise specified.

Benchmark Boiler Intake and Output Ranges

MODEL	INPUT RANGE (BTU/HR.)		OUTPUT RANGE (BTU/HR.)	
	MINIMUM	MAXIMUM	MINIMUM	MAXIMUM
BMK 750	50,000 (14.6 kW)	750,000 (220 kW)	47,750 (14 kW)	716,250 (210 kW)
BMK 1000	50,000 (14.6 kW)	1,000,000 (293 kW)	48,300 (14.15 kW)	968,000 (284 kW)
BMK 1500	75,000 (22 kW)	1,500,000 (440 kW)	64,500 (18.9 kW)	1,395,000 (409 kW)
BMK 2000	100,000 (29.3 kW)	2,000,000 (586 kW)	86,000 (25.2 kW)	1,860,000 (545 kW)
BMK 2500	167,000 (48.9 kW)	2,500,000 (732 kW)	144,000 (42.2 kW)	2,395,000 (702 kW)
BMK 3000	200,000 (58.6 kW)	3,000,000 (879 kW)	174,000 (51.0 kW)	2,874,000 (842 kW)

The output of the boiler is a function of the unit's firing rate (valve position) and return water temperature.

When installed and operated in accordance with this Instruction Manual, the BMK 750 – 2000 and 5000 & 6000 comply with the NO_x emission standards outlined in: **South Coast Air Quality Management District (SCAQMD), Rule 1146.2**. In addition, the BMK 2500 – 6000 comply with the **Bay Area Air Quality Management District regulation 9, Rule 7**.

Whether used in singular or modular arrangements, the BMK boilers offer the maximum venting flexibility with minimum installation space requirements. These boilers are Category II and IV, positive pressure appliances. Single and/or multiple breeched units are capable of operation in the following vent configurations:

- **Room Combustion Air:**
 - Vertical Discharge
 - Horizontal Discharge
- **Ducted Combustion Air:**
 - Vertical Discharge
 - Horizontal Discharge

These boilers are capable of being vented utilizing Polypropylene and AL29-4C vent systems.

FORWARD

The Benchmark's advanced electronics are available in several selectable modes of operation offering the most efficient operating methods and energy management system integration.

AERCO Technical Terminology Meanings	
TERMINOLOGY	MEANING
A (Amp)	Ampere
ACS	AERCO Control System, AERCO's boiler management systems
ADDR	Address
AGND	Analog Ground
ALRM	Alarm
ANSI	American National Standards Institute,
ASME	American Society of Mechanical Engineers
AUX	Auxiliary
BAS	Building Automation System, often used interchangeably with EMS (see below)
Baud Rate	Symbol rate, or simply the number of distinct symbol changes (signaling events) transmitted per second. It is not equal to bits per second, unless each symbol is 1 bit long.
BMK (Benchmark)	AERCO's Benchmark series boilers
BMS or BMS II	AERCO Boiler Management Systems
BLDG (Bldg)	Building
BST	AERCO on-board Boiler Sequencing Technology
BTU	British Thermal Unit. A unit of energy approximately equal to the heat required to raise 1 pound (0.45 kg) of water 1°F (0.55 °C)
BTU/HR	BTUs per Hour (1 BTU/hr = 0.29 W)
CCP	Combination Control Panel
CCS	Combination Control System
C-More Controller	A control system developed by AERCO and currently used in all Benchmark, Innovation and KC1000 Series product lines.
CFH	Cubic Feet per Hour (1 CFH = 0.028 m ³ /hr)
CO	Carbon Monoxide
COMM (Comm)	Communication
Cal.	Calibration
CNTL	Control
CPU	Central Processing Unit
DBB	Double Block and Bleed, a gas trains containing 2 Safety Shutoff Valves (SSOVs) and a solenoid operated vent valve.
DIP	Dual In-Line Package, a type of switch
ECU	Electronic Control Unit (O ₂ sensor)
EMS	Energy Management System; often used interchangeably with BAS
FM	Factory Mutual. Used to define boiler gas trains.

AERCO Technical Terminology Meanings	
TERMINOLOGY	MEANING
GF-xxxx	Gas Fired (an AERCO document numbering system)
GND	Ground
HDR	Header
Hex	Hexadecimal Number (0 – 9, A – F)
HP	Horse Power
HX	Heat Exchanger
Hz	Hertz (Cycles Per Second)
I.D.	Inside Diameter
IGN	Ignition
IGST Board	Ignition/Stepper Board, contained in C-More Controller
INTLK (INTL'K)	Interlock
I/O	Input/Output
I/O Box	Input/Output (I/O) Box currently used on Benchmark, Innovation and KC1000 Series products
IP	Internet Protocol
ISO	International Organization for Standardization
Lbs.	Pounds (1 lb = 0.45 kg)
LED	Light Emitting Diode
LN	Low Nitrogen Oxide
MA (mA)	Milliampere (1 thousand th of an ampere)
MAX (Max)	Maximum
MBH	1000 BTUs per Hour
MIN (Min)	Minimum
Modbus®	A serial, half-duplex data transmission protocol developed by AEG Modicon
NC (N.C.)	Normally Closed
NO (N.O.)	Normally Open
NO _x	Nitrogen Oxide
NPT	National Pipe Thread
O ₂	Oxygen
O.D.	Outside Diameter
OMM & O&M	Operation and Maintenance Manual
onAER	AERCO's on-line remote monitoring system
PCB	Printed Circuit Board
PMC Board	Primary Micro-Controller (PMC) board, contained in the C-More
P/N	Part Number
POC	Proof of Closure
PPM	Parts per Million

FORWARD

AERCO Technical Terminology Meanings	
TERMINOLOGY	MEANING
PSI	Pounds per Square Inch (1 PSI = 6.89 kPa)
PTP	Point-to-Point (usually over RS232 networks)
P&T	Pressure and Temperature
ProtoNode	Hardware interface between BAS and a boiler or water heater
PVC	Poly Vinyl Chloride, a common synthetic plastic
PWM	Pulse Width Modulation
REF (Ref)	Reference
RES.	Resistive
RS232 (or EIA-232)	A standard for serial, full-duplex (FDX) transmission of data based on the RS232 Standard
RS422 (or EIA-422)	A standard for serial, full-duplex (FDX) transmission of data based on the RS422 Standard
RS485 (or EIA-485)	A standard for serial, half-duplex (HDX) transmission of data based on the RS485 Standard
RTN (Rtn)	Return
SETPT (Setpt)	Setpoint Temperature
SHLD (Shld)	Shield
SPDT	Single Pole Double Throw, a type of switch
SSOV	Safety Shut Off Valve
TEMP (Temp)	Temperature
Terminating Resistor	A resistor placed at each end of a daisy-chain or multi-drop network in order to prevent reflections that may cause invalid data in the communication
Tip-N-Tell	A device that indicates if a package was tipped during shipping
UL	A business that tests and validates products
VAC	Volts, Alternating Current
VDC	Volts, Direct Current
VFD	Vacuum Fluorescent Display, also Variable Frequency Drive
W	Watt
W.C.	Water Column, a unit of pressure (1 W.C. = 249 Pa)
µA	Micro amp (1 million th of an ampere)

SECTION 1: SAFETY PRECAUTIONS

1.1 WARNINGS & CAUTIONS

Installers and operating personnel **MUST**, at all times, observe all safety regulations. The following warnings and cautions are general and must be given the same attention as specific precautions included in these instructions. In addition to all the requirements included in this AERCO Instruction Manual, the installation of units **MUST** conform with local building codes, or, in the absence of local codes, ANSI Z223.1 (National Fuel Gas Code Publication No. NFPA-54) for gas-fired boilers and ANSI/NFPA5B for LP gas-fired boilers. Where applicable, the equipment shall be installed in accordance with the current Installation Code for Gas Burning Appliances and Equipment, CSA B149.1, and applicable Provincial regulations for the class; which should be carefully followed in all cases. Authorities having jurisdiction should be consulted before installations are made.

See section 1.4 for important information regarding installation of units within the Commonwealth of Massachusetts.

IMPORTANT!
This Instruction Manual is an integral part of the product and must be maintained in legible condition. It must be given to the user by the installer and kept in a safe place for future reference.

WARNING!

- Do not use matches, candles, flames, or other sources of ignition to check for gas leaks.
- Fluids under pressure may cause injury to personnel or damage to equipment when released. Be sure to shut off all incoming and outgoing water shutoff valves. Carefully decrease all trapped pressures to zero before performing maintenance.
- Before attempting to perform any maintenance on the unit, shut off all gas and electrical inputs to the unit.
- The exhaust vent pipe of the unit operates under a positive pressure and therefore must be completely sealed to prevent leakage of combustion products into living spaces.
- Electrical voltages up to **120 VAC (BMK 750 – 2000) and 208 or 460 VAC (BMK 2500/3000) and 24 volts AC** may be used in this equipment. Therefore the cover on the unit's power box (located behind the front panel door) must be installed at all times, except during maintenance and servicing.
- A three-pole switch must be installed on the electrical supply line of the unit. The switch must be installed in an easily accessible position to quickly and safely disconnect electrical service. Do not affix switch to unit sheet metal enclosures.

CAUTION!

- Many soaps used for gas pipe leak testing are corrosive to metals. The piping must be rinsed thoroughly with clean water after leak checks have been completed.
- **DO NOT** use this boiler if any part has been under water. Call a qualified service technician to inspect and replace any part that has been under water.

SECTION 1: SAFETY PRECAUTIONS

1.2 EMERGENCY SHUTDOWN

If overheating occurs or the gas supply fails to shut off, close the manual gas shutoff valve (Figure 1-1) located external to the unit.

NOTE:

The Installer must identify and indicate the location of the emergency shutdown manual gas valve to operating personnel.



Figure 1-1: Manual Gas Shutoff Valve

In addition, to ensure safety an emergency shutdown procedure that addresses the following points should be designed and implement at the site:

- For automatically operated unattended boilers located in a boiler room, provide a manually operated remote shutdown switch or circuit breaker located just inside or outside each boiler room door. Design the system so activation of the emergency shutdown switch or circuit breaker will immediately shut off the fuel supply to the unit(s).
- For automatically operated unattended boilers in a location other than a boiler room, provide a manually operated remote shutdown switch or circuit breaker marked for easy identification at a location readily accessible in the event of boiler mis-operation.
- Design the system so activation of the emergency shutdown switch or circuit breaker will immediately shut off the fuel.
- For boilers monitored and/or operated from a continuously occupied control room, provide an emergency shutdown switch in the control room that is hard-wired to immediately shut off the fuel upon activation.

1.3 PROLONGED SHUTDOWN

If there is an emergency, turn off the electrical power supply to the boiler and close the manual gas valve located upstream the unit. The installer must identify the emergency shut-off device.

If the boiler needs to be shut down for a prolonged period, follow the instructions in Section 4.10: *Shutting Boiler Down For Extended Period* of this manual.

After prolonged shutdown, it is recommended that the procedures in Section 4: *Initial Startup* and Section 5: *Safety Device Testing* of the *Benchmark PLATINUM 750-3000 Installation and Startup Guide* (OMM-0115, GF-200) be performed to verify that all system-operating parameters are correct.

1.4 IMPORTANT – FOR MASSACHUSETTS INSTALLATIONS

Requirements For Massachusetts Installations

Boiler Installations within the Commonwealth of Massachusetts must conform to the following requirements:

- Boiler must be installed by a plumber or a gas fitter who is licensed within the Commonwealth of Massachusetts.
- Prior to unit operation, the complete gas train and all connections must be leak tested using a non-corrosive soap.
- The vent termination must be located a minimum of 4 feet above grade level. If side-wall venting is used, the installation must conform to the following requirements **extracted from 248 CMR 5.08 (2)**:

(a) For all side wall horizontally vented gas fueled equipment installed in every dwelling, building or structure used in whole or in part for residential purposes, including those owned or operated by the Commonwealth and where the side wall exhaust vent termination is less than seven (7) feet above finished grade in the area of the venting, including but not limited to decks and porches, the following requirements shall be satisfied:

1. INSTALLATION OF CARBON MONOXIDE DETECTORS: At the time of installation of the side wall horizontal vented gas fueled equipment, the installing plumber or gasfitter shall observe that a hard wired carbon monoxide detector with an alarm and battery back-up is installed on the floor level where the gas equipment is to be installed. In addition, the installing plumber or gasfitter shall observe that a battery operated or hard wired carbon monoxide detector with an alarm is installed on each additional level of the dwelling, building or structure served by the side wall horizontal vented gas fueled equipment. It shall be the responsibility of the property owner to secure the services of qualified licensed professionals for the installation of hard wired carbon monoxide detectors.

a. In the event that the side wall horizontally vented gas fueled equipment is installed in a crawl space or an attic, the hard wired carbon monoxide detector with alarm and battery back-up may be installed on the next adjacent floor level.

b. In the event that the requirements of this subdivision can not be met at the time of completion of installation, the owner shall have a period of thirty (30) days to comply with the above requirements; provided, however, that during said thirty (30) day period, a battery operated carbon monoxide detector with an alarm shall be installed.

2. APPROVED CARBON MONOXIDE DETECTORS: *Each carbon monoxide detector as required in accordance with the above provisions shall comply with NFPA 720 and be ANSI/UL 2034 listed and IAS certified.*

3. SIGNAGE: A metal or plastic identification plate shall be permanently mounted to the exterior of the building at a minimum height of eight (8) feet above grade directly in line with the exhaust vent terminal for the horizontally vented gas fueled heating appliance or equipment. The sign shall read, in print size no less than one-half (1/2) inch in size, "**GAS VENT DIRECTLY BELOW. KEEP CLEAR OF ALL OBSTRUCTIONS**". (Continued)

SECTION 1: SAFETY PRECAUTIONS

Requirements For Massachusetts Installations

4. INSPECTION: The state or local gas inspector of the side wall horizontally vented gas fueled equipment shall not approve the installation unless, upon inspection, the inspector observes carbon monoxide detectors and signage installed in accordance with the provisions of 248 CMR 5.08(2)(a)1 through 4.

(b) **EXEMPTIONS:** The following equipment is exempt from 248 CMR 5.08(2)(a)1 through 4:

1. The equipment listed in Section 10 entitled "Equipment Not Required To Be Vented" in the most current edition of NFPA 54 as adopted by the Board; and
2. Product Approved side wall horizontally vented gas fueled equipment installed in a room or structure separate from the dwelling, building or structure used in whole or in part for residential purposes.

(c) **MANUFACTURER REQUIREMENTS - GAS EQUIPMENT VENTING SYSTEM PROVIDED.** When the manufacturer of Product Approved side wall horizontally vented gas equipment provides a venting system design or venting system components with the equipment, the instructions provided by the manufacturer for installation of the equipment and the venting system shall include:

1. Detailed instructions for the installation of the venting system design or the venting system components; and
2. A complete parts list for the venting system design or venting system.

(d) **MANUFACTURER REQUIREMENTS - GAS EQUIPMENT VENTING SYSTEM NOT PROVIDED.** When the manufacturer of a Product Approved side wall horizontally vented gas fueled equipment does not provide the parts for venting the flue gases, but identifies "special venting systems", the following requirements shall be satisfied by the manufacturer:

1. The referenced "special venting system" instructions shall be included with the appliance or equipment installation instructions; and
2. The "special venting systems" shall be Product Approved by the Board, and the instructions for that system shall include a parts list and detailed installation instructions.

(e) A copy of all installation instructions for all Product Approved side wall horizontally vented gas fueled equipment, all venting instructions, all parts lists for venting instructions, and/or all venting design instructions shall remain with the appliance or equipment at the completion of the installation.

.....[End of Extracted Information From 248 CMR 5.08 (2)].....

SECTION 2: OPERATION

2.1 INTRODUCTION

The information in this section provides a guide to the operation of the Benchmark Boiler using the C-More Controller mounted on the front of the unit. It is imperative that the initial startup of this unit be performed by factory trained personnel. Operation prior to initial startup by factory trained personnel may void the equipment warranty. In addition, the following WARNINGS and CAUTIONS must be observed at all times.

WARNING!

- **ELECTRICAL VOLTAGES IN THIS SYSTEM INCLUDE 120 VAC (BMK 750 – 2000) and 208 or 460 VAC (BMK 2500/3000) and 24 volts AC.** It must be serviced only by factory certified service technicians.
- **DO NOT ATTEMPT TO DRY FIRE THE UNIT.** Starting the unit without a full water level can seriously damage the unit and may result in injury to personnel or property damage. This situation will void any warranty.

CAUTION!

All of the installation procedures in the *Benchmark PLATINUM 750–3000 Installation and Startup Guide*, OMM-0115 (GF-200) must be completed before attempting to start the unit.

2.2 C-MORE CONTROLLER DESCRIPTION

All Benchmark boilers utilize the C-More Controller shown in Figure 2-1. This panel contains all of the controls, indicators and displays necessary to operate, adjust and troubleshoot the boiler. These operating controls, indicators and displays are listed and described in Table 2-1. Additional information on these items is provided in the individual operating procedures and menu descriptions provided in this section.

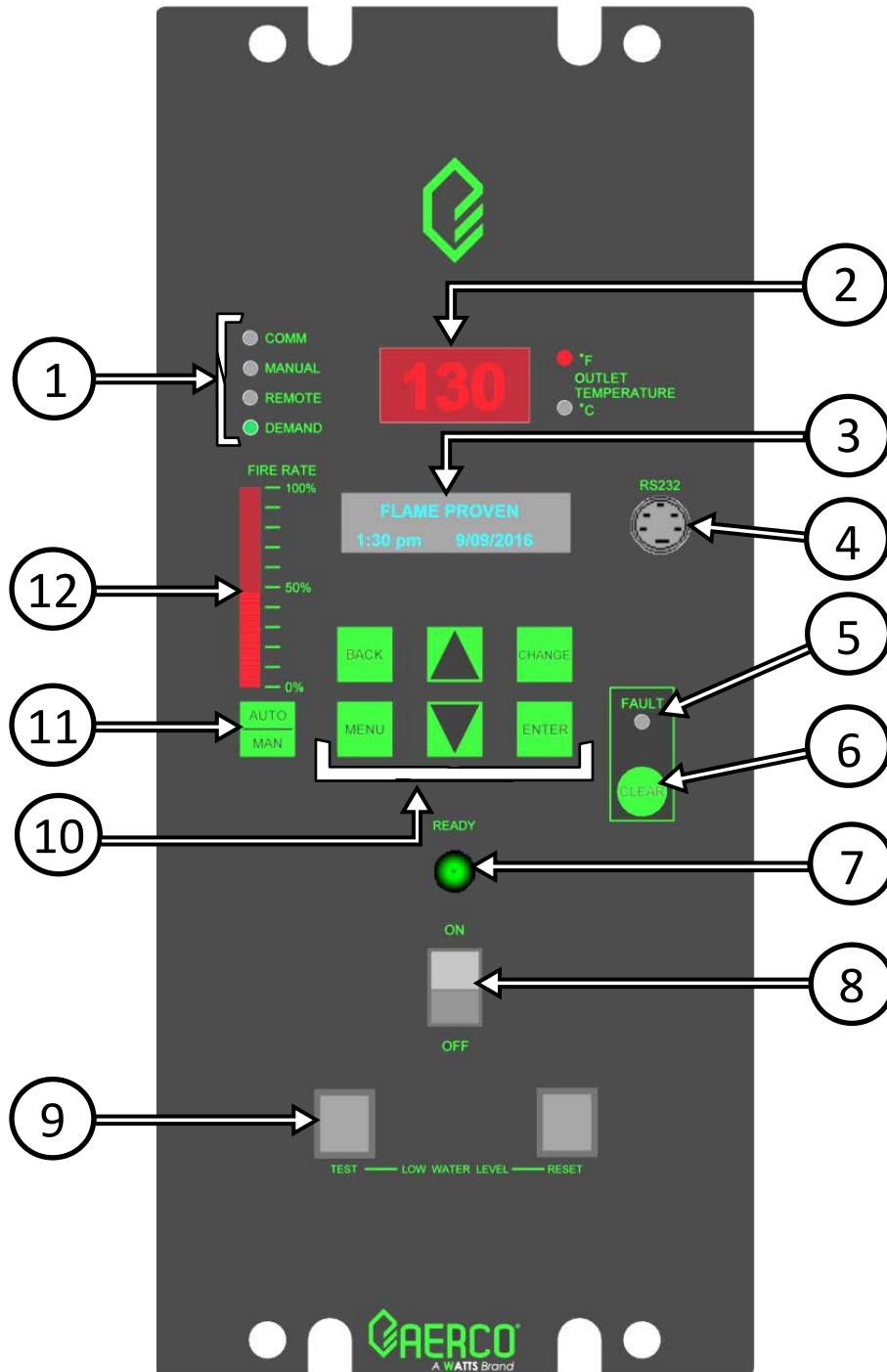

Figure 2-1: C-More Controller Front View

TABLE 2-1: Controls, Indicators, and Displays (ref. Figure 2-1)

ITEM	CONTROL, INDICATOR or DISPLAY	FUNCTION
LED STATUS INDICATORS		
Four Status LEDs indicate the current operating status as follows:		
1	<p>COMM =</p> <p>MANUAL =</p> <p>REMOTE =</p> <p>DEMAND =</p>	<p>Lights when RS232 communication is occurring – see Item 4.</p> <p>Lights when the valve position (fire rate) is being controlled using the front panel keypad. This mode of operation is for service technician use only.</p> <p>Lights when the unit is being controlled by an external signal from an Energy Management System.</p> <p>Lights when there is a demand for heat.</p>
2	OUTLET TEMPERATURE Display	<p>3-Digit, 7-Segment LED display continuously displays the outlet water temperature. The °F or °C LED next to the display lights to indicate whether the displayed temperature is in degrees Fahrenheit or degrees Celsius. The °F or °C blinks when operating in the DEADBAND mode.</p> <p>On a BST Manager, display flashes & shows header temperature.</p>
3	VFD Display	<p>Vacuum Fluorescent Display (VFD) consists of 2 lines each capable of displaying up to 16 alphanumeric characters. The information displayed includes:</p> <ul style="list-style-type: none"> • Startup Messages • Fault Messages • Operating Status Messages • Menu Selection • BST Messages
4	RS232 Port	<p>This port is used only by factory-trained personnel to monitor onAER communications, in combination with the RS232 Adaptor Cable (P/N 124675).</p>
5	FAULT Indicator	<p>Red FAULT LED indicator lights when a boiler alarm condition occurs. An alarm message will appear in the VFD.</p>
6	CLEAR Key	<p>Turns off the FAULT indicator and clears the alarm message if the alarm is no longer valid. Lockout type alarms will be latched and cannot be cleared by simply pressing this key. Troubleshooting may be required to clear these types of alarms.</p>
7	READY Indicator	<p>Lights when ON/OFF switch is set to ON and when all Pre-Purge conditions have been satisfied.</p>
8	ON/OFF switch	<p>Enables and disables boiler operation.</p>
9	LOW WATER LEVEL TEST/RESET switches	<ul style="list-style-type: none"> • Allows operator to test operation of the water level monitor. • Pressing TEST opens the water level probe circuit and simulates a Low Water Level alarm. • Pressing RESET resets the water level monitor circuit. • Pressing the CLEAR key (item 6) resets the display.

SECTION 2: OPERATION

TABLE 2-1: Controls, Indicators, and Displays (ref. Figure 2-1)

ITEM	CONTROL, INDICATOR or DISPLAY	FUNCTION
10	MENU KEYPAD	
	Six (6) keys which provide the following functions for the C-More Controller menus:	
	MENU	Steps through the main menu categories shown in Figure 2-2. The menu categories wrap around in the order shown.
	BACK	Allows you to go back to the previous menu level without changing any information. Continuously pressing this key will bring you back to the default status display in the VFD. Also, this key allows you to go back to the top of a main menu category.
	▲ (UP) Arrow	When in one of the main menu categories (Figure 2-2), pressing the ▲ arrow key will select the displayed menu category. If the CHANGE key was pressed and the menu item is flashing, pressing the ▲ arrow key will increment the selected setting.
	▼ (DOWN) Arrow	When in one of the main menu categories (Figure 2-2), pressing this key will select the displayed menu category. If the CHANGE key was pressed and the menu item is flashing, pressing the ▼ arrow key will decrement the selected setting.
	CHANGE	Permits a setting to be changed (edited). When the CHANGE key is pressed, the displayed menu item will begin to flash. Pressing the ▲ or ▼ arrow key when the item is flashing will increment or decrement the displayed setting.
ENTER	Saves the modified menu settings in memory. The display will stop flashing.	
11	AUTO/MAN switch	<p>This switch toggles the boiler between the AUTOMATIC and MANUAL modes of operation. When in the MANUAL (MAN) mode, the front panel controls are enabled and the MANUAL status LED lights. Manual operation is for service only.</p> <p>When in the AUTOMATIC (AUTO) mode, the MANUAL status LED will be off and the front panel controls disabled.</p>
12	VALVE POSITION Bargraph	20 segment red LED bargraph continuously shows the Air/Fuel Valve position in 5% increments from 0 to 100%

2.3 C-MORE CONTROLLER MENUS

The C-More Controller incorporates an extensive menu structure which permits the operator to set up, and configure the unit. The menu structure consists of five major menu categories which are applicable to this manual. These categories are shown in Figure 2-2. Each of the menus shown, contain options which permit operating parameters to be viewed or changed. The menus are protected by password levels to prevent unauthorized use.

Prior to entering the correct password, the options contained in the *Operation*, *Setup*, *Configuration* and *Tuning* menu categories can be viewed. However, with the exception of Internal Setpoint Temperature (*Configuration* menu), none of the viewable menu options can be changed.

Once the valid **level 1 password (159)** is entered, the options listed in the *Setup*, *Configuration* and *Tuning* menus can be viewed and changed, if desired. The *Combustion Cal* menu is protected by the **level 2 password (6817)**, which is used in initial startup (see Section 4: *Initial Startup* of the *Benchmark PLATINUM 750–3000 Installation and Startup Guide*, OMM-0115 (GF-200)), to perform combustion calibration prior to service use.

2.3.1 Menu Navigation and Processing Procedure

Accessing and initiating each menu and option is accomplished using the menu keys shown in Figure 2-1. Therefore, it is imperative that you be thoroughly familiar with the following basic steps before attempting to perform specific menu procedures:

Menu Navigation and Processing Procedure Instructions

1. The C-More Controller will normally be in the *Operating* menu and the VFD will display the current unit status. Pressing the ▲ or ▼ arrow key will display the other available data items in the *Operating* menu.
2. Press the **MENU** key. The display will show the *Setup* menu, which is the next menu category shown in Figure 2-2. This menu contains the Password option which must be entered if other menu options will be changed.
3. Continue pressing the **MENU** key until the desired menu is displayed.
4. With the desired menu displayed, press the ▲ or ▼ arrow key. The first option in the selected menu will be displayed.
5. Continue to press the ▲ or ▼ arrow key until the desired menu option is displayed. Pressing the ▲ arrow key will display the available menu options in the Top-Down sequence. Pressing the ▼ arrow key will display the options in the Bottom-Up sequence. The menu options will wrap-around after the first or last available option is reached.
6. To change the value or setting of a displayed menu option, press the **CHANGE** key. The displayed option will begin to flash. Press the ▲ or ▼ arrow key to scroll through the available menu option choices for the option to be changed. The menu option choices do not wrap around.
7. To select and store a changed menu item, press the **ENTER** key.

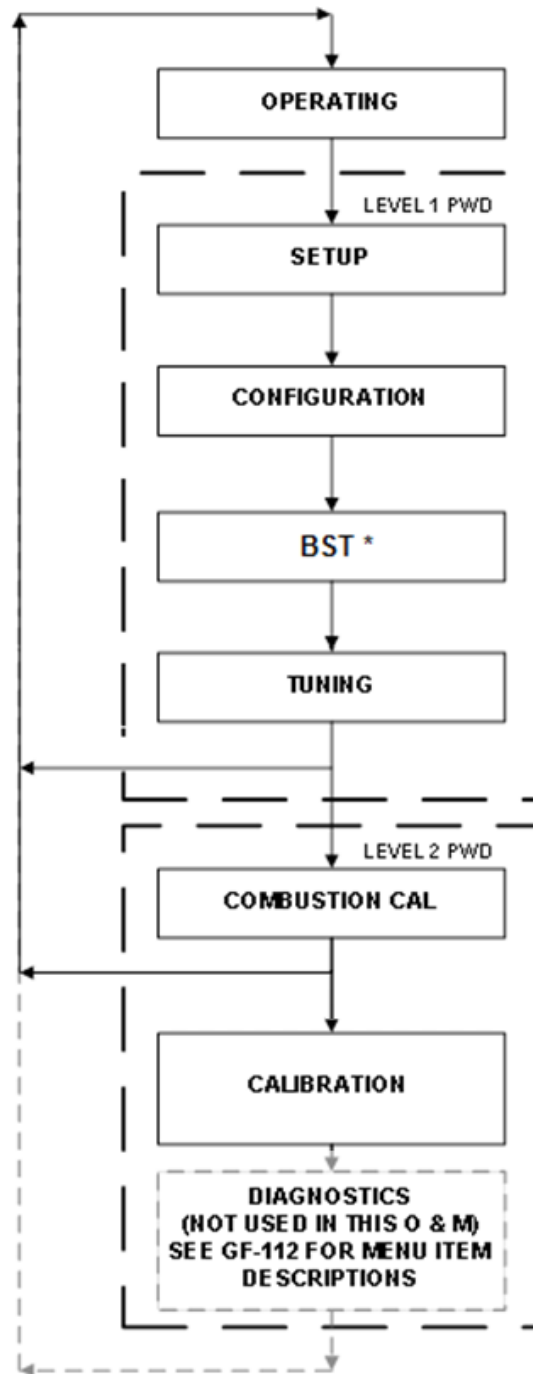

* Only if BST (Boiler Sequencing Technology) is enabled. BST is described in detail in Section 6 of the *Benchmark PLATINUM 750–3000 Installation and Startup Guide*, OMM-0115 (GF-200).

Figure 2-2: Menu Structure

NOTE:

The following sections provide brief descriptions of the options contained in each menu. Refer to Appendix A for detailed descriptions of each menu option. Refer to Appendix B for a list and descriptions of startup, status and error messages.

2.4 OPERATING Menu

The *Operating* menu displays a number of key operating parameters for the unit. All items in this menu except *O2 Monitor* (item 15) are “Read-Only” and cannot be changed. This menu can be accessed without entering a password.

A full description of each item appears in Appendix A-1.

TABLE 2-2: OPERATING Menu				
MENU ITEM DISPLAY		AVAILABLE CHOICES OR LIMITS		Appears Only If Enabled in:
		Minimum	Maximum	
1	Active Setpoint	40°F (4.4°C)	240°F (116°C)	
2	Outlet Temp	30°F (-1.1°C)	240°F (116°C)	Configuration Menu
3	Inlet Temp	30°F (-1.1°C)	240°F (116°C)	
4	Air Temp	-70°F (-56.7°C)	245°F (118°C)	
5	Outdoor Temp	-70°F (-56.7°C)	130°F (54.4°C)	Configuration Menu
6	Valve Position In	0%	100%	
7	Valve Position Out	0%	100%	Configuration Menu
8	FFWD Temp	30°F (-1.1°C)	240°F (115.6°C)	
9	Exhaust Temp	Displays current exhaust temperature		
10	Flame Strength	0%	100%	
11	Min Flame Str	Not Used		
12	O2 Monitor	Enable	Disable	O2 Monitor = Enabled
13	Oxygen Level	0%	21%	
14	Ignition Time	0.00	10.00	
15	SSOV Time to OPN	0.00	10.00	
16	Spark Current	0 amps	2.5 amps	
17	Run Cycles	0	999,999,999	
18	Run Hours	0	999,999,999	
19	Fault Log	0	19	

An additional parameter associated with the Operating menu, **Manual Valve Pos** (Min = 0, Max = 100) does not appear in this menu, but can be displayed by pushing the **Auto/Man** button on the C-More Controller’s front face.

2.5 SETUP Menu

The *Setup* menu permits the operator to enter the unit password (**159**), which is required to change the menu options. To prevent unauthorized use, the password will time-out after 1 hour. Therefore, the correct password must be reentered when required. In addition to permitting password entries, the *Setup* menu is also used to enter date and time, and units of temperature measurements. A view-only software version display is also provided to indicate the current C-More Controller software version.

A full description of each item appears in Appendix A-2.

TABLE 2-3: SETUP Menu				
MENU ITEM DISPLAY		AVAILABLE CHOICES OR LIMITS		DEFAULT
		Minimum	Maximum	
1	Password	0	9999	0
2	Language	English		English
3	Time	12:00 am	11:59 pm	12:00
4	Date	01/01/00	12/31/99	01/01/00
5	Unit of Temp	Fahrenheit or Celsius		Fahrenheit
6	Comm Address	0	127	0
7	Baud Rate	2400, 4800, 9600, 19.2K		9600
8	onAER Mode	Ethernet or SD Card		Ethernet
9	Min Upload Timer	0	9,999 Sec	0
10	Unit Alpha	E, G, H, R, N or A		A
11	Unit Year	0	99	0
12	Unit Serial #	0	9999	0
13	Software	Ver 0.00	Ver 9.99	Current software version

2.6 CONFIGURATION Menu

The *Configuration* menu permits adjustment of the Internal Setpoint (Setpt) temperature regardless of whether the valid password has been entered. Setpt is required for operation in the **CONSTANT SETPOINT** mode. The remaining options in this menu require the valid password to be entered, prior to changing existing entries. This menu contains a number of other configuration settings which may or may not be displayed, depending on the current operating mode setting.

A full description of each item appears in Appendix A-3.

NOTE:
The *Configuration* menu settings are Factory-Set in accordance with the requirements specified for each individual order. Under normal operating conditions, no changes will be required.

TABLE 2-4: CONFIGURATION Menu

MENU ITEM DISPLAY		AVAILABLE CHOICES OR LIMITS		DEFAULT
		Minimum	Maximum	
1	Internal Setpt	40°F (4.4°C)	240°F (115.6°C)	130°F (54.4°C)
2	Unit Type	BMK Blr Std, BMK Blr Std Dual, BMK Blr LN, BMK Blr LN Dual		BMK Boiler LN
3	Unit Size (Only displays sizes available for the unit)	750 MBH (220 kW), 1000 MBH (293 kW), 1500 MBH (439.6 kW), 2000 MBH (586.1 kW), 2500 MBH (732.6 kW), 3000 MBH (879.2 kW)		750 MBH (220 kW),
4	Fuel Type	Natural Gas or Propane		Natural Gas in standard and dual fuel models, Propane in propane only models
5	Boiler Mode	Constant Setpoint, Remote Setpoint, Direct Drive, Combination, Outdoor Reset		Constant Setpoint
6	Remote Signal (If Mode = Remote Setpoint, Direct Drive or Combination)	4 – 20 mA/1 – 5V 0 -20 mA/0 – 5V PWM Input (Legacy BMS), Network		4 – 20 mA, 1-5V
7	Outdoor Sensor	Enabled or Disabled		Disabled
8	* Bldg Ref Temp (If Mode = Outdoor Reset)	40°F (4.4°C)	230°F (110°C)	70°F (21.1°C)
9	* Reset Ratio (If Mode = Outdoor Reset)	0.1	9.9	1.2
10	* System Start Tmp (If Outdoor Sensor = Enabled)	30°F (-1.1°C)	100°F (37.8°C)	60°F (15.6°C)
11	Setpt Lo Limit	40°F (4.4°C)	Setpt Hi Limit	60°F (15.6°C)

SECTION 2: OPERATION

TABLE 2-4: CONFIGURATION Menu				
MENU ITEM DISPLAY		AVAILABLE CHOICES OR LIMITS		DEFAULT
		Minimum	Maximum	
12	Setpt Hi Limit	Setpt Lo Limit	210°F (98.9°C)	180°F (82.2°C)
13	Temp Hi Limit	40°F (4.4°C)	210°F (98.9°C)	195°F (90.6°C)
14	Max Valve Position	40%	100%	100%
15	Pump Delay Timer	0 min.	30 min.	0 min.
16	Aux Start On Dly	0 sec.	120 sec.	0 sec.
17	Failsafe Mode	Shutdown or Constant Setpt		Constant Setpt
18	Analog Output	Off, Setpoint, Outlet Temp, Valve Pos 4-20mA, valve Pos 0-10v		Valve Pos 0-10v (Do NOT change)
19	Low Fire Timer	2 sec.	600 sec.	2 sec.
20	Setpt Limiting	Enabled or Disabled		Disabled
21	Setpt Limit Band	0°F (0°C)	10°F (5.5°C)	5°F (2.75°C)
22	Network Timeout	5 sec.	999 sec.	30 sec.
23	Shutoff Dly Temp	0°F (0°C)	25°F (13.75°C)	10°F (5.5°C)
24	Demand Offset	0°F (0°C)	25°F (13.75°C)	10°F (5.5°C)
25	Deadband High	0°F (0°C)	25°F (13.75°C)	5°F (2.75°C)
26	Deadband Low	0°F (0°C)	25°F (13.75°C)	5°F (2.75°C)
27	IGST Version	Displays current IGST version		V2.02
28	IGN Time Setting	Displays 4 sec. or 7 sec. depending on wiring harness installed		
29	Slow Shutdown	Enabled or Disabled		Disabled
30	Slow Sht Duration	0 sec.	9,999 sec.	60 sec.
31	Slow Sht Threshold	40%	100%	60
32	O2 Warnings	Enabled or Disabled		Disabled
33	O2 Trim ID	Displays 4 digit AERtrim ID		
34	Fixed ID	Displays unit's fixed 4 digit ID		
35	O2 Trim Key	Displays AERtrim 4 digit license key		
36	O2 Trim Menu	Enabled or Disabled		Disabled
37	BST Menu	Enabled or Disabled		Disabled

*NOTE

The *Bldg Ref Temp* and *Reset Ratio* menu Items are only displayed when the *Outdoor Sensor*, item # 7 is set to **Enabled**.

CAUTION!

DO NOT change the *Analog Output* menu item from its default setting (Valve Position 0-10V).

2.7 TUNING Menu

The *Tuning* menu items are Factory set for each individual unit. Do not change these menu entries unless specifically requested to do so by factory-trained personnel.

A full description of each item appears in Appendix A-4.

TABLE 2-5: TUNING Menu					
MENU ITEM DISPLAY		MINIMUM	MAXIMUM	DEFAULT	
1	Prop Band	1°F (0.55°C)	120°F (66°C)	70°F (38.5°C)	
2	Integral Gain	0.00	2.00	1.00	
3	Derivative Time	0.0 min	2.00 min	0.0min	
4	Warmup Prop Band	1°F (0.55°C)	120°F (66°C)	95 °F (52°C)	
5	Warmup Int Gain	0.00	2.00	0.50	
6	Warmup PID timer	0 sec.	240 sec.	20 sec.	
7	Reset Defaults?	Yes, No, Are You Sure?			No

2.8 COMBUSTION CAL Menu

The *Combustion Cal* (Calibration) menu is protected by the level 2 password (**6817**), which must be entered to view or change the menu items shown in Table 2-6, 2-7 and 2-8. These menu items are used to vary the speed of the unit's blower motor based on air temperature and air density at prescribed Air/Fuel Valve positions (% open). This is accomplished by providing a DC drive voltage to the motor, which then adjusts the rotational speed of the blower to maximize combustion efficiency and ensure the unit conforms to the Nitrogen Oxide (NO_x) and Carbon Monoxide (CO) emissions specified in the combustion calibration instructions in Section 4.4 of the *Benchmark PLATINUM 750–3000 Installation and Startup Guide*, OMM-0115 (GF-200).

CAL Voltage values are factory adjusted for each unit prior to shipping, and so may differ from the defaults shown in the tables below. A full description of each item appears in Appendix A-5.

2.8.1 BMK 750/1000 COMBUSTION CAL Menu

TABLE 2-6: COMBUSTION CAL Menu: BMK 750/1000					
MENU ITEM DISPLAY		MINIMUM	MAXIMUM	DEFAULT	
				Natural gas	Propane
1	CAL Voltage 18%	0.25	10.00	2.10	2.10
2	CAL Voltage 30%	0.25	10.00	2.55	2.55
3	CAL Voltage 45%	0.25	10.00	3.10	3.10
4	CAL Voltage 60%	0.25	10.00	3.50	3.50
5	CAL Voltage 80%	0.25	10.00	4.60	4.60
6	CAL Voltage 100%	0.25	10.00	5.60	5.60
7	SET Valve Position	0%	100%	0%	0%
8	Blower Output	Monitor Blower Output Voltage		0.00	0.00
9	Set Stdby Volt	0 V	10.0 V	2.00	2.00
10	Oxygen Level	0%	25%	0.0	0.0

2.8.2 BMK 1500/2000 COMBUSTION CAL Menu

TABLE 2-7a: COMBUSTION CAL Menu: BMK 1500/2000
SINGLE FUEL – NATURAL GAS

MENU ITEM DISPLAY		MINIMUM	MAXIMUM	DEFAULT	
				BMK 1500	BMK 2000
1	CAL Voltage 16%	0.25	10.00	1.80	–
	CAL Voltage 18%			–	1.40
2	CAL Voltage 30%	0.25	10.00	2.30	3.80
3	CAL Voltage 40%	0.25	10.00	2.50	4.30
4	CAL Voltage 50%	0.25	10.00	2.90	5.40
5	CAL Voltage 70%	0.25	10.00	3.80	6.40
6	CAL Voltage 100%	0.25	10.00	7.90	9.50
7	SET Valve Position	0%	100%	Variable	
8	Blower Output	Displays current value			
9	Set Stdby Volt	0	10.00 V	2.00 V	2.00 V
10	Oxygen Level	Displays current value			

TABLE 2-7b: COMBUSTION CAL Menu: BMK 1500/2000
DUAL FUEL

MENU ITEM DISPLAY		MINIMUM	MAXIMUM	DEFAULT			
				Natural gas *		Propane	
				BMK 1500	BMK 2000	BMK 1500	BMK 2000
1	CAL Voltage: 16%	0.25	10.00	1.50	2.10	–	–
	CAL Voltage: 18%			–	–	1.20	2.10
2	CAL Voltage 30%	0.25	10.00	2.60	4.50	2.30	3.50
3	CAL Voltage 40%	0.25	10.00	3.20	4.50	2.80	3.90
4	CAL Voltage 50%	0.25	10.00	3.30	4.50	3.00	4.10
5	CAL Voltage 70%	0.25	10.00	4.10	4.80	3.50	4.10
6	CAL Voltage 100%	0.25	10.00	8.30	9.80	7.70	8.90
7	SET Valve Position	0	100	Variable			
8	Blower Output	Displays current value					
9	Set Stdby Volt	0	10.0	2.00	2.00	2.00	2.00
10	Oxygen Level	Displays current value					

* The default values for Natural Gas on Dual Fuel units are different than the default values for Natural Gas on Single Fuel units. These values do NOT apply to single fuel units.

2.8.3 BMK 2500/3000 COMBUSTION CAL Menu

TABLE 2-8a: COMBUSTION CAL Menu: BMK 2500/3000					
SINGLE FUEL – NATURAL GAS					
MENU ITEM DISPLAY		MINIMUM	MAXIMUM	DEFAULT	
				BMK 2500	BMK 3000
1	CAL Voltage 16%	0.25	10.00	2.20	–
	CAL Voltage 14%			–	2.80
2	CAL Voltage 30%	0.25	10.00	4.10	4.60
3	CAL Voltage 40%	0.25	10.00	4.80	5.00
4	CAL Voltage 50%	0.25	10.00	5.30	5.50
5	CAL Voltage 70%	0.25	10.00	6.80	6.90
6	CAL Voltage 100%	0.25	10.00	8.50	9.10
7	SET Valve Position	0%	100%	Variable	
8	Blower Output	Displays current value			
9	Set Stdby Volt	0	10.00 V	2.00 V	2.00 V
10	Oxygen Level	Displays current value			

TABLE 2-8b: COMBUSTION CAL Menu: BMK 2500/3000 DUAL FUEL							
MENU ITEM DISPLAY		MINIMUM	MAXIMUM	DEFAULT			
				NATURAL GAS *		PROPANE	
				BMK 2500	BMK 3000	BMK 2500	BMK 3000
1	CAL Voltage: 14%	0.25	10.00	–	2.40	–	–
	CAL Voltage: 16%	0.25	10.00	2.15	–	–	–
	CAL Voltage: 18%	0.25	10.00	–	–	2.00	2.30
	CAL Voltage: 20%	0.25	10.00	2.10	–	–	–
	CAL Voltage: 22%	0.25	10.00	–	–	2.00	–
2	CAL Voltage 30%	0.25	10.00	3.90	5.40	3.30	4.40
3	CAL Voltage 45%	0.25	10.00	5.60	6.60	4.60	5.40
4	CAL Voltage 65%	0.25	10.00	–	7.00	–	5.70
	CAL Voltage 70%	0.25	10.00	6.60	–	5.60	–
5	CAL Voltage 75%	0.25	10.00	–	–	–	–
	CAL Voltage 85%	0.25	10.00	–	8.00	–	7.00
6	CAL Voltage 100%	0.25	10.00	8.50	8.70	7.90	8.60
7	SET Valve Position	0	100	Variable			
8	Blower Output	Displays current value					
9	Set Stdby Volt	0	10.0	2.00	2.00	2.00	2.00
10	Oxygen Level	Displays current value					

* The default values for Natural Gas on Dual Fuel units are different than the default values for Natural Gas on Single Fuel units. These values shown DO NOT APPLY to single fuel units.

2.9 BST (Boiler Sequencing Technology) Menu

The *BST* menu must be enabled in order to be displayed and accessed. The **BST Menu** item, located at the end of the *Configuration* menu (item 37 in Table 2-4), must be set to **Enabled**.

The *BST* menu contains all of the items required to configure, operate and monitor the functionality of the BST System. There are over 50 items in this menu, and selecting any particular item from the list, for inspection or modification, could be time consuming. As a result, the *BST* menu has been segmented into FIVE logical groups based on functionality.

The five Item groups are:

1. **BST Monitor Items**
2. ***BST SETUP MENU***
3. ***OPERATE MENU***
4. ***TEMP CTRL MENU***
5. ***BST COMM MENU***

These displayed item groups are displayed in UPPER CASE letters, and are bounded by an asterisk * in order to readily identify them within the item list.

The Items contained in group 1 (BST Monitor Items) are *always* displayed within the menu, as these items are critical for proper system operation. Therefore, the BST Monitor Items Header itself is *not* displayed.

The Items contained in groups 2-5 are *not displayed* unless that particular item group has been enabled from the C-More keypad.

TABLE 2-9: BST Menu					
MENU ITEM DISPLAY		AVAILABLE CHOICES OR LIMIT			DEFAULT
		Minimum	Maximum		
1	BST Mode	Off	BST Client	BST Manager	Off
2	BST Setpoint	BST Setpt Lo Limit		BST Setpt Hi Limit	130°F (54.4°C)
3	Header Temp	Read Only – current Header temperature in °F			N/A
4	BST Fire Rate	0	100%		Fire rate %
5	BST Ave Fire Rate	0	100%		Avg Fire Rate %
6	BST Outdoor Temp	Read Only – current outdoor temperature in °F			N/A
7	Units Available	0	8		Units Present
8	Units Ignited	0	8		Units firing
9	BST Valve State	0 (CLOSED)		1 (OPEN)	0
10	1 BST Comm Errors 8	0	9		0
11	1 BST Units 8	0 – 8 (see * NOTE below)			0
12	*BST SETUP MENU*	Disabled		Enabled	Disabled
13	BST Setpoint Mode	Constant Setpoint	Remote Setpoint	Outdoor Reset	Constant Setpt
14	BST Remote Signl	4-20 mA/1-5 VDC	0-20 mA/0-5 VDC	Network	Network
15	Head Temp Source	Network		FFWD Temp	FFWD Temp
16	Mdbus Temp Units	Degrees C or Degrees F			Degrees C

SECTION 2: OPERATION

TABLE 2-9: BST Menu

MENU ITEM DISPLAY		AVAILABLE CHOICES OR LIMIT		DEFAULT
		Minimum	Maximum	
17	Header Temp Addr	0	255	240
18	Header Temp Point	0	255	14
19	BST Outdoor Sens	Disabled	Enabled	Disabled
20	Outdr Tmp Source	Outdoor Temp	Network	Outdoor Temp
21	Outdoor Tmp Addr	0	255	240
22	Outdoor Tmp Pnt	0	255	215
23	BST Auto Mstr	No	Yes NOTE! A Modbus temperature transmitter must be installed in conjunction with this feature.	No
24	BST Auto Timer	10 sec	120 sec	30 sec
25	Remote Intlk Use	Boiler Shutdown	System Shutdown	System Shutdown
26	One Boiler Mode	Off	On-Outlet Temp On-Avg Temp	Off
27	1 Blr Threshold	10	35	25
28	Setpoint Setback	Disable	Enable	Disable
29	Setback Setpoint	BST Setpt Lo Limit	BST Setpt HI Limit	130°F (54.4°C)
30	Setback Start	12:00am	11:59pm	12.00am
31	Setback End	12:00am	11:59pm	12.00am
32	Rate Threshold	1°F (0.55°C)	30°F (16.5°C)	15°F (8.25°C)

33	*OPERATE MENU*	Disabled	Enabled	Disabled
34	BST Next On VP	16%	100%	50%
35	BST Max Boilers	1	8	8
36	BST On Delay	30 sec	300 sec	60 sec
37	BST On Timeout	15 sec	300 sec	60 Sec
38	Valve Override	Off	Closed Open	Off
39	Valve Off Delay	0	15 min	1 min
40	BST Sequencing	Run Hours	Unit Size Select Lead	Run Hours
41	Select Lead Unit	0	127	0
42	Select Lag Unit	0	127	0
43	Lead/Lag Hours	25 hours	225 hours	72 hours

44	*TEMP CTRL MENU*	Disabled	Enabled	Disabled
45	BST Temp Hi Limit	40°F (4.4°C)	210°F (98.9°C)	210°F (98.9°C)
46	BST Setpt Lo Limit	40°F (4.4°C)	BST Setpt HI Limit	60°F (15.5°C)
47	BST Setpt HI Limit	BST Setpt Lo Limit	220°F (104.4°C)	195°F (90.6°C)
48	BST Prop Band	1°F (-17.2°C)	120°F (48.9°C)	100°F (37.8°C)
49	BST Intgral Gain	0.00	2.00	0.50
50	BST Deriv Time	0.00 Min	2.00 Min	0.10 Min

SECTION 2: OPERATION

TABLE 2-9: BST Menu

MENU ITEM DISPLAY		AVAILABLE CHOICES OR LIMIT		DEFAULT
		Minimum	Maximum	
51	BST Deadband Hi	0	25	1
52	BST Deadband Lo	0	25	1
53	Deadband En Time	0	120 Sec	30 Sec
54	BST FR Up Rate	1	120	20
55	BST Bldg Ref Tmp	40°F (4.4°C)	230°F (110°C)	70°F (21.1°C)
56	BST Reset Ratio	0.1	9.9	1.2
57	System Start Tmp	30°F (-1.1°C)	120°F (48.9°C)	60°F (15.6°C)

58	*BST COMM MENU*	Disabled	Enabled	Disabled
59	Comm Address	0	127	0
60	BST Min Addr	1	128	1
61	BST Max Addr	1	128	8
62	SSD Address	0	250	247
63	SSD Poll Control	0	1000	0
64	Err Threshold	1	9	5
65	SSD Temp Format	Degrees	Points	Degrees
66	BST Upld Timer	0	9999 sec	0

*** NOTE:**

The **1 BST Units 8** menu item shows the current status for each unit controlled by BST, up to a maximum of 8 units. The possible characters displayed are:

- = Off Line
- * = Not Available (fault, etc.)
- 0 = Off
- 1 = On,
- A = Lead On
- a = Lead Off
- B = Lag On
- b = Lag Off
- S = Setpoint Limit Active

The following example shows the status of 5 units being controlled by BST where:

- Unit 1 & 3 are **On**
- Unit 2 is **Off**
- Unit 4 is **Not Available**
- Unit 5 is **Lead On**
- Unit 6 is **Lag Off**

1 BST Units 8

1	0	1	*	A	b		
---	---	---	---	---	---	--	--

2.10 CALIBRATION MENU

The Calibration menu is used by factory trained service personnel to adjust or reset the parameters listed below.

A full description of each item appears in Appendix A-6.

TABLE 2-10: CALIBRATION Menu				
MENU ITEM DISPLAY		AVAILABLE CHOICES OR LIMIT		DEFAULT
		Minimum	Maximum	
1	Stepper Fbk	Cal 0%, Verify 50%, Cal 100%		Cal 0%
2	Purge Timer	5 sec.	60 sec	Depends on unit type/size
3	Post Purge Timer	0 sec.	60 sec.	0 sec.
4	IGN Position	5%	60%	Depends on unit type/size
5	Ign Pos Hold Tmr	0 sec.	60 sec.	0 sec.
6	FFWD Temp Dsply	Enabled or Disabled		Disabled
7	Outlet Tmp Dsply	Enabled or Disabled		Disabled
8	Inlet Tmp Dsply	Enabled or Disabled		Disabled
9	Valv Pos Out Dsp	Enabled or Disabled		Enabled
10	Exhaust Tmp Dsp	Enabled or Disabled		Disabled
11	Exhaust Safety	Enabled or Disabled		Enabled
12	Flue Material	PVC,CPVC; PolyPro; Stainless		PVC,CPVC
13	Exhst Fault Temp	100 °F	500 °F	200 °F
14	Exhst Module Temp	100 °F	500 °F	190 °F
15	Exhst Warn Temp	100 °F	500 °F	180 °F
16	Exhst Tmp VP Adj	0	10	5
17	Exhst Adj Rate	1	600	30
18	VP Change Rate	5	600	25
19	VP Up Rate	0.5	60.0	Depends on unit type/size
20	VP Down Rate	0.5	60.0	Depends on unit type/size
21	Purge Blwr Offst	-1.0	8.0	Depends on unit type/size
22	4-20mA Purge Pct	60%	100%	70%
23	PWM In Adj	-5.0%	5.0%	0.0%
24	Analog In Adj	-5.0%	5.0%	0.0%
25	Flow In Adj	-5.0%	5.0%	0.0%
26	Supply Gas Pressure In Adj	-5.0%	5.0%	0.0%
27	Gas Plate dp In Adj	-5.0%	5.0%	0.0%
28	mA Out Adj	-1.0 mA	1.0 mA	0.0 mA

SECTION 2: OPERATION

TABLE 2-10: CALIBRATION Menu				
MENU ITEM DISPLAY		AVAILABLE CHOICES OR LIMIT		DEFAULT
		Minimum	Maximum	
29	A/F Sensitivity	1%	5%	2%
30	Power Reset	Automatic or Manual		Automatic
31	Water Temp Reset	Automatic or Manual		Automatic
32	Gas Press Reset	Automatic or Manual		Manual
33	Min Off Time	0 Min	15 Min	1 Min
34	Heatr Tuning Dsp	Enabled or Disabled		Disabled
35	Heatr Bkpt Dsp	Enabled or Disabled		Disabled
36	Stop Level	0%	Start Level	16
37	Start Level	Stop Level	40%	22
38	Skip Range Cntr	10	95	40
39	Skip Range Span	0	3	0%
40	Skip Speed	0.5	2.0	0.5%
41	O2 Gain	0.500	1.500	1.000
42	O2 Offset	-24.0	+2.0	1.0
43	O2 Sensor	Enabled or Disabled		Depends on unit type/size
44	Cal Temp Sensors	Off or Start		Off
45	FFWD Temp Offset	-20	+20	0
46	Exhst Tmp Offset	-20	+20	0
47	Outdr Air Offset	-20	+20	0
48	Inlet Air Offset	-20	+20	0
49	Inlet Wtr Offset	-20	+20	0
50	Outlet Wtr Offset	-20	+20	0
51	24 hr Max Cycles	0	9999	0
52	24 hr Max Ovrtemp	0	9999	0
53	0-10v Out Test	0.0	10.0	0.00
54	Spark Monitor	Enabled or Disabled		Depends on unit type/size
55	Min Spark Amps	0.0 Amps	2.5 Amps	0.10 Amps
56	Max Spark Amps	0.0 Amps	2.5 Amps	0.40 Amps

SECTION 3: MODES OF OPERATION

3.1 INTRODUCTION

The boiler is capable of being operated in any one of six different modes. The following sections provide descriptions of each of these operating modes. Each boiler is shipped from the factory tested and configured for the ordered mode of operation. All temperature related parameters are at their factory default values, which work well in most applications. However, it may be necessary to change certain parameters to customize the unit to the system environment. After reading this section, parameters can be customized to suit the needs of the specific application. A complete listing and descriptions of the temperature related parameters are included in Appendix A, while factory defaults are listed in Sections 2.4 – 2.10, above.

3.2 INDOOR/OUTDOOR RESET MODE

This mode of operation is based on outside air temperatures. As the outside air temperature decreases, the supply header temperature will increase and vice versa. For this mode, it is necessary to install an outside air sensor as well as select a building reference temperature and a reset ratio.

3.2.1 Reset Ratio

Reset ratio is an adjustable number from 0.1 to 9.9. Once adjusted, the supply header temperature will increase by that number for each degree that the outside air temperature decreases. For instance, if a reset ratio of 1.6 is used, for each degree that outside air temperature decreases the supply header temperature will increase by 1.6 degrees.

3.2.2 Building Reference Temperature

This is a temperature from 40°F to 230°F (4.4°C to 110°C). Once selected, it is the temperature that the system references to begin increasing its temperature. For instance, if a reset ratio of 1.6 is used, and we select a building reference temperature of 70°F (21.1°C), then at an outside temperature of 69°F (20.6°C), the supply header temperature will increase by 1.6° to 71.6°F (0.9°C to 22°C).

3.2.3 Outdoor Air Temperature Sensor Installation

The outdoor air temperature sensor must be mounted on the North side of the building in an area where the average outside air temperature is expected. The sensor must be shielded from the sun's direct rays, as well as direct impingement by the elements. If a cover or shield is used, it must allow free air circulation. The sensor may be mounted **up to 200 feet (61m)** from the unit. Sensor connections are made at the Input/Output (I/O) Box on the front of the boiler. Connections are made at the terminals labeled *OUTDOOR AIR IN* and *AIR SENSOR COM* inside the I/O Box. Use shielded 18 to 22 AWG wire for connections. A wiring diagram is provided on the cover of the I/O Box. Refer to Section 2.10: *AC Electrical Power Wiring* of the *Benchmark PLATINUM 750–3000 Installation and Startup Guide*, OMM-0115 (GF-200) for additional information on wiring.

3.2.4 Indoor/Outdoor Startup

Startup in the INDOOR/OUTDOOR RESET mode is accomplished as follows:

NOTE:

A design engineer typically provides design outdoor air temperature and supply header temperature data.

Indoor / Outdoor Setup Instructions

1. Refer to the Indoor/Outdoor reset ratio charts in Appendix E.
2. Choose the chart corresponding to the desired Building Reference Temperature.
3. Go down the left column of the chart to the coldest design outdoor air temperature expected in your area.
4. Once the design outdoor air temperature is chosen, go across the chart to the desired supply header temperature for the design temperature chosen in step 3.
5. Next, go up that column to the RESET RATIO row to find the corresponding reset ratio.
6. Access the *Configuration* menu and scroll through it until the display shows **BLDG REF TEMP** (Building Reference Temperature). If necessary, refer to Section 2.3: *C-More Controller Menus*, above, for detailed instructions on navigating the menus.
7. Press the **CHANGE** key. The display will begin to flash.
8. Use the **▲** and **▼** arrow keys to select the desired Building Reference Temperature.
9. Press **ENTER** to save any changes.
10. Next, scroll through the *Configuration* menu until the display shows **RESET RATIO**.
11. Press the **CHANGE** key. The display will begin to flash.
12. Use the **▲** and **▼** arrow keys to select the Reset Ratio determined in step 5.
13. Press **ENTER** to save the change.

3.3 CONSTANT SETPOINT MODE

The CONSTANT SETPOINT mode is used when a fixed header temperature is desired. Common uses of this mode of operation include water source heat pump loops, and indirect heat exchangers for potable hot water systems or processes.

No external sensors are required to operate in this mode. While it is necessary to set the desired setpoint temperature, it is not necessary to change any other temperature-related functions. The unit is factory preset with settings that work well in most applications. Prior to changing any temperature-related parameters, other than the setpoint, it is suggested that an AERCO representative be contacted. See Appendix A for descriptions of temperature-related functions, and Sections 2.4 – 2.10 for their range of values and factory defaults.

3.3.1 Setting the Setpoint

The setpoint temperature of the unit is adjustable from 40°F to 240°F (4.4°C to 115.6°C). To set the unit for operation in the CONSTANT SETPOINT mode, you must set menu items **Internal Setpt** and **Boiler Mode** in the *Configuration* menu as follows:

TABLE 3-1: Constant Setpoint Mode Settings

MENU OPTION	SETTING
Internal Setpt	Select desired setpoint using ▲ and ▼ arrow keys (40°F to 240°F, 4.4°C to 115.6°C)
Boiler Mode	Constant Setpoint

See Section 2.3: *C-More Controller Menus* for detailed instructions on changing menu options.

3.4 REMOTE SETPOINT MODES

The unit's setpoint can be remotely controlled by an Energy Management System (EMS) or Building Automation System (BAS). The Remote Setpoint can be driven by a current or voltage signal within the following ranges:

- 4-20 mA/1-5 VDC
- 0-20 mA/0-5 VDC

The factory default setting for the REMOTE SETPOINT mode is 4 - 20 mA/1 - 5 VDC. With this setting, a 4 to 20 mA/1 to 5 VDC signal, sent by an EMS or BAS, is used to change the unit's setpoint. The 4 mA/1V signal is equal to a 40°F (4.4°C) setpoint while a 20 mA /5V signal is equal to a 240°F (115.6°C) setpoint. When a 0 to 20 mA/0 to 5 VDC signal is used, 0 mA is equal to a 40°F (4.4°C) setpoint.

In addition to the current and voltage signals described above, the REMOTE SETPOINT mode can also driven by a RS-485 Modbus Network signal from an EMS or BAS.

The REMOTE SETPOINT modes of operation can be used to drive single as well as multiple units.

NOTE:

If a voltage, rather than current signal is used to control the remote setpoint, a DIP switch adjustment must be made on the PMC Board located in the C-More Controller. Contact your local AERCO representative for details.

In order to enable the REMOTE SETPOINT mode, you must set menu items **Boiler Mode** and **Remote Signal** in the *Configuration* menu as follows:

TABLE 3-2: Remote Setpoint Mode Settings

MENU OPTION	SETTING
Boiler Mode	Remote Setpoint
Remote Signal	4-20mA/1-5V, 0-20mA/0-5V, or Network

Refer to section 2.3: *C-More Controller Menus* for detailed instructions on changing menu options.

If the Network setting is selected for RS-485 Modbus operation, a valid Comm Address must be entered in the *Setup* menu. Refer to Modbus Communication Manual GF-114 for additional information.

While it is possible to change the settings of temperature related functions, the unit is factory preset with settings that work well in most applications. It is suggested that an AERCO representative be contacted, prior to changing any temperature related function settings. See Appendix A for descriptions of temperature-related functions, and Sections 2.4 – 2.10 for their range of options and factory defaults.

3.4.1 Remote Setpoint Field Wiring

The only wiring connections necessary for the REMOTE SETPOINT mode are connection of the remote signal leads from the source to the unit's I/O Box. The I/O Box is located on the front panel of the boiler. For either a 4-20mA/0-5V or a 0-20mA/0-5V setting, the connections are made at the ANALOG IN terminals in the I/O Box. For a Network setting, the connections are made at the RS-485 COMM terminals in the I/O Box. The signal must be floating, (ungrounded) at the I/O Box and the wire used must be a two wire shielded pair from 18 to 22 AWG. Polarity must be observed. The source end of the shield must be connected at the source. When driving multiple units, each unit's wiring must conform to the above.

3.4.2 Remote Setpoint Startup

Since this mode of operation is factory preset and the setpoint is being externally controlled, no startup instructions are necessary. In this mode, the REMOTE LED will light when the external signal is present.

To operate the unit in the MANUAL mode, press the **AUTO/MAN** switch. The REMOTE LED will go off and the MANUAL LED will light.

To change back to the REMOTE SETPOINT mode, simply press the **AUTO/MAN** switch. The REMOTE LED will again light and the MANUAL LED will go off.

3.5 DIRECT DRIVE MODES

The unit's air/fuel valve position (% open) can be changed by a remote signal which is typically sent from an Energy Management System (EMS) or from a Building Automation System (BAS). The Direct Drive mode can be driven by a current or voltage signal within the following ranges:

- 4-20 mA/1-5 VDC
- 0-20 mA/0-5 VDC

The factory default setting for the DIRECT DRIVE mode is 4-20 mA/1-5 VDC. With this setting, a 4 to 20 mA signal, sent by an EMS or BAS is used to change the unit's valve position from 0% to 100%. A 4 mA/1V signal is equal to a 0% valve position, while a 20 mA /5V signal is equal to a 100% valve position. When a 0-20 mA/0-5 VDC signal is used, zero is equal to a 0% valve position.

In addition to the current and voltage signals described above, the DIRECT DRIVE mode can also driven by a RS-485 Modbus Network signal from an EMS or BAS.

When in a DIRECT DRIVE mode, the unit is a slave to the EMS or BAS and does not have a role in temperature control. DIRECT DRIVE can be used to drive single, or multiple units.

SECTION 3 – MODES OF OPERATION

NOTE:

If a voltage, rather than current signal is used to control the remote setpoint, a DIP switch adjustment must be made on the CPU Board located in the C-More Controller. Contact your local AERCO representative for details.

To enable the DIRECT DRIVE mode, you must set menu items **Boiler Mode** and **Remote Signal** in the *Configuration* menu as follows:

TABLE 3-3: Direct Drive Mode Settings

MENU OPTION	SETTING
Boiler Mode	Direct Drive
Remote Signal	4-20mA/1-5V, 0-20mA/0-5V, or Network

Refer to section 2.3: *C-More Controller Menus* for instructions on changing menu options.

If the Network setting is selected for RS-485 Modbus operation, a valid Comm Address must be entered in the *Setup* menu. Refer to Modbus Communication Manual GF-114 for additional information.

3.5.1 Direct Drive Field Wiring

The only wiring connections necessary for DIRECT DRIVE mode are connection of the remote signal leads from the source to the unit’s I/O Box. For either a 4-20mA/0-5V or a 0-20mA/0-5V setting, the connections are made at the ANALOG IN terminals in the I/O Box. For a Network setting, the connections are made at the RS-485 COMM terminals in the I/O Box. The signal must be floating, (ungrounded) at the I/O Box and the wire used must be a two wire shielded pair from 18 to 22 AWG. Polarity must be observed. The source end of the shield must be connected at the source. When driving multiple units, each unit’s wiring must conform to the above.

3.5.2 Direct Drive Startup

Since this mode of operation is factory preset and the valve position is being externally controlled, no startup instructions are necessary. In this mode, the REMOTE LED will light when the signal is present.

To operate the unit in MANUAL mode, press the **AUTO/MAN** switch. The REMOTE LED will go off and the MANUAL LED will light.

To change back to the Direct Drive mode, simply press the **AUTO/MAN** switch. The REMOTE LED will again light and the MANUAL LED will go off.

3.6 AERCO CONTROL SYSTEM (ACS)

NOTE:

ACS is for installations with 9 or more boilers. It utilizes only RS-485 signaling to the boiler. Installations with 1 to 8 boilers can use Boiler Sequencing Technology (BST), as described in Section 6 of the *Benchmark PLATINUM 750–3000 Installation and Startup Guide*, OMM-0115 (GF-200).

The **ACS** mode of operation is used in conjunction with an AERCO Control System. The **ACS** mode is used when it is desired to operate multiple units in the most efficient manner possible. For this mode of operation, an ACS Header Sensor must be installed **between 2 and 10 feet (0.61 and 3m)** downstream of the **last** boiler in the boiler plant's supply water header. The ACS can control up to 40 boilers; up to 32 via Modbus (RS-485) network communication. For ACS programming, operation, and Header Sensor installation details, see the *ACS Operations Guide* (OMM-081, GF-131). For operation via an RS-485 Modbus network, refer to *Modbus Communication Manual* (OMM-0035, GF-114). To enable the ACS mode, you must set menu items **Boiler Mode** and **Remote Signal** in the *Configuration* menu as follows:

TABLE 3-4: ACS Mode Settings

MENU OPTION	SETTING
Boiler Mode	Direct Drive
Remote Signal	Network (RS485)

Refer to section 2.3: *C-More Controller Menus* for instructions on changing menu options.

3.6.1 ACS External Field Wiring

Wiring connections for RS-485 Modbus control are made between the 485 A- and 485 B+ terminals on the ACS (boilers 9 through 40) and the RS-485 COMM terminals in the I/O Box on the front of the boilers.

Wire the units using shielded twisted pair wire between 18 and 22 AWG. Observe the proper polarity for the ACS RS-485 COMM wiring connections. Shields should be terminated only at the ACS and the boiler end must be left floating. Each unit's wiring must conform to the above.

3.6.2 ACS Setup and Startup

This mode of operation is factory preset and the ACS controls the firing rate (air/fuel valve % open position). There are no setup instructions for each individual unit.

To operate the unit in MANUAL mode, press the **AUTO/MAN** switch. The REMOTE LED will go off and the MANUAL LED will light

To change back to the ACS mode, simply press the **AUTO/MAN** switch. The REMOTE LED will again light and the MANUAL LED will go off.

3.7 COMBINATION CONTROL SYSTEM (CCS)

NOTE:

Only ACS can be utilized for the Combination Control System.

A Combination Control System (CCS) is one that uses multiple boilers to cover both space-heating and domestic hot water needs. The theory behind this type of system is that the maximum space-heating load and the maximum domestic hot water load do not occur simultaneously. Therefore, boilers used for domestic hot water are capable of switching between constant setpoint and ACS control.

For a typical CCS, an adequate number of boilers are installed to cover the space-heating load on the design-day. However, one or more units are used for the domestic hot water load as well. These boilers are the combination units and are referred to as the combo boilers. The combo boilers heat water to a constant setpoint temperature. That water is then circulated through a heat exchanger in a domestic hot water storage tank.

Only the AERCO Control System (ACS) is necessary to configure this system if only a single valve is used to switch from space heating to domestic hot water. However, the ACS Relay Panel is required in combination with the ACS when there are up to two isolation valves, boiler interlocks, and/or a Domestic Hot Water (DHW) pump in a Combination heating plant where AERCO boilers are being used for both Building Heat and Domestic Hot Water heating.

The following two options are available for using a combination system; one that uses only the ACS, and one that requires the optional ACS Relay Box:

- **OPTION 1** - This option is selected when the ACS controls a boiler plant containing up to eight combination boilers that are Domestic Hot Water Priority (DHW PRIORITY) boilers, along with building heat (BLDG HEAT) boilers, and *one* hydronic isolation valve in the main header between the BLDG HEAT boilers and the DHW PRIORITY boilers.
- **OPTION 2** – When this option is selected, the ACS Relay Panel must be used in conjunction with the ACS. For this option, the ACS controls a boiler plant containing up to eight combination boilers that are divided up into Building Priority (BLDG PRIORITY) boilers and Domestic Hot Water Priority (DHW PRIORITY) boilers, along with building heat (BLDG HEAT) boilers, and using *two* hydronic isolation valves in the main header, one between the BLDG HEAT and BLDG PRIORITY boilers, and the other between the BLDG PRIORITY and the DHW PRIORITY boilers.

In Option 2, when the space-heating load is such that when all the space-heating boilers are at the 100% valve position, the ACS will then ask the ACS Relay Box for the domestic boilers to become space-heating boilers. Provided the domestic hot water load is satisfied, the combo (hot water) boilers will then become space-heating boilers. If the domestic hot water load is not satisfied, the combo boiler(s) remain on the domestic hot water load. If the combo boilers switch over to space heating, but there is a call for domestic hot water, the ACS Relay Box switches the combo units back to the domestic load. The ACS in combination with the ACS Relay Box will ask the BLDG PRIORITY boilers to help with domestic hot water heating if the DHW PRIORITY boilers are not able to satisfy the domestic hot water demand.

When the combo units are satisfying the domestic load, they are in the CONSTANT SETPOINT mode of operation. When the combo units switch over to space heating, their mode of operation changes to follow the ACS command. For more information concerning the operation of the ACS, consult the ACS Operations Guide, GF-131. For more information on the ACS Relay Box, see section 2.14 in the same manual.

3.7.1 Combination Control System Field Wiring

Wiring for this system is between the ACS, the ACS Relay Box, and the terminals in the I/O Box. Wire the units using a shielded twisted pair of 18 to 22 AWG wire. When wiring multiple units, each unit’s wiring must conform to the above.

3.7.2 Combination Control System Setup and Startup

Setup for the COMBINATION mode requires entries to be made in the *Configuration* menu for boiler mode, remote signal type and setpoint (see Section 2.6: *Configuration Menu* for details). The setpoint is adjustable from 40°F to 190°F (4.4°C to 87.8°C).

To enable the COMBINATION mode, you must set menu items **Boiler Mode**, **Remote Signal** and **Internal Setpt** in the *Configuration* menu as follows:

TABLE 3-5: Combination Mode Settings

MENU OPTION	SETTING
Boiler Mode	Combination
Remote Signal	Network
Internal Setpt	40°F to 190°F (4.4°C to 87.8°C)

Refer to section 2.3: *C-More Controller Menus* for instructions on changing menu options.

While it is possible to change other temperature-related functions for COMBINATION mode, these functions are preset to their factory default values. These default settings work well in most applications. It is suggested that AERCO be contacted prior to changing settings other than the unit’s setpoint. For a complete listing of temperature related function defaults, see Sections 2.4 – 2.10.

To set the unit to the MANUAL mode, press the **AUTO/MAN** switch. The MANUAL LED will light.

To set the unit back to the AUTO mode, press the **AUTO/MAN** switch. The MANUAL LED will go off and the REMOTE LED will light.

When the boiler is switched to ACS control, the ACS controls the valve position. There are no setup requirements to the boiler(s) in this mode.

SECTION 4: MAINTENANCE

4.1 MAINTENANCE SCHEDULE

All Benchmark boilers require regular routine maintenance to keep up efficiency and reliability. For best operation and life of the unit, the following routine maintenance procedures should be performed in the time periods specified in Table 4-1. For a complete inspection check list see ASME CSD-1 chart.

The following maintenance kits are available through your local AERCO Sales Representative:

Model	Kit P/N	Type	Components Serviced
750-3000	58025-01	12 Month	Ignitor, Flame Rod & Condensate trap
750-1000	58025-08	24-Month	58025-01 plus: Burner, LWCO, Air Filter replacement
	58025-17	Water/Fireside	Same as 58025-08 except <i>clean</i> Air Filter
1500-2000	58025-13	24-Month	58025-01 plus: Burner, LWCO, Air Filter replacement
	58025-19	Water/Fireside	Same as 58025-13 except <i>clean</i> Air Filter
2500-3000	58025-10	24-Month	58025-01 plus: Burner, LWCO, Air Filter replacement
	58025-18	Water/Fireside	Same as 58025-10 except <i>clean</i> Air Filter

WARNING!

Prior to servicing, ensure that the following guidelines are strictly observed:

- Disconnect the AC power supply by turning off the service switch and AC supply circuit breaker.
- Shut off the gas supply at the manual shut-off valve provided with the unit
- Allow the unit to cool to a safe water temperature to prevent burning or scalding

TABLE 4-1: Maintenance Schedule

SEC	ITEM	6 MOS.	12 MOS.	24 MOS.	LABOR TIME
4.2	Igniter-Injector Kit (P/N 58023)	*Inspect	Inspect, replace if necessary	Replace	15 mins.
4.3	Flame Detector Kit (P/N 24356-1)	*Inspect	Inspect, replace if necessary	Replace	15 mins.
4.4	Lean O ₂ Sensor (P/N 61026)	*Inspect	Inspect		15 mins.
**	Combustion Calibration	*Check	Check		1 hr.
4.5	Testing of Safety Devices		See ASME CSD-1 Chart		45 mins.
4.6	Burner			Inspect	2 hrs.
4.7	Condensate Drain Trap	*Inspect	Inspect, Clean & Replace Gaskets	Inspect, Clean & Replace Gaskets	30 mins.
4.8	Air Filter		Clean	Replace	15 mins.

* Only performed after initial 6 month period after initial startup.

** Combustion Calibration instructions are in Section 4.4 of OMM-0115 (GF-200)

4.2 IGNITER-INJECTOR

The igniter-injector (Kit P/N **58023**) is located on the burner plate at the top of the boiler. In addition to providing the ignition spark required to light the burner, the igniter-injector also contains a gas injector tube which connects to the staged ignition assembly. Figure 4-1a through Figure 4-1c shows the complete burner assembly removed from the boiler and indicates the location of the igniter-injector flame detector and other related components.

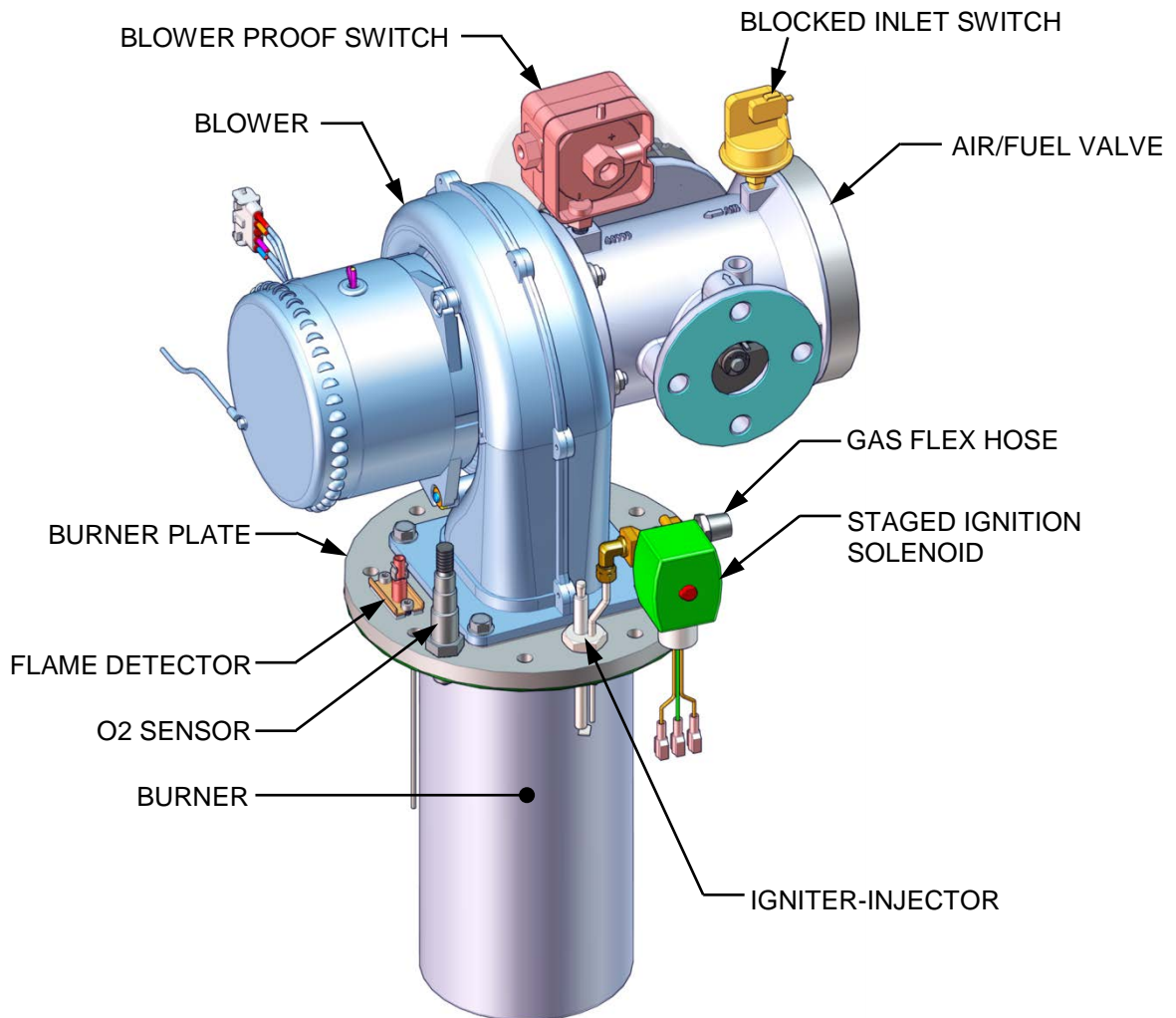

Figure 4-1a: BMK 750/1000 Burner Assembly (Removed from Boiler)

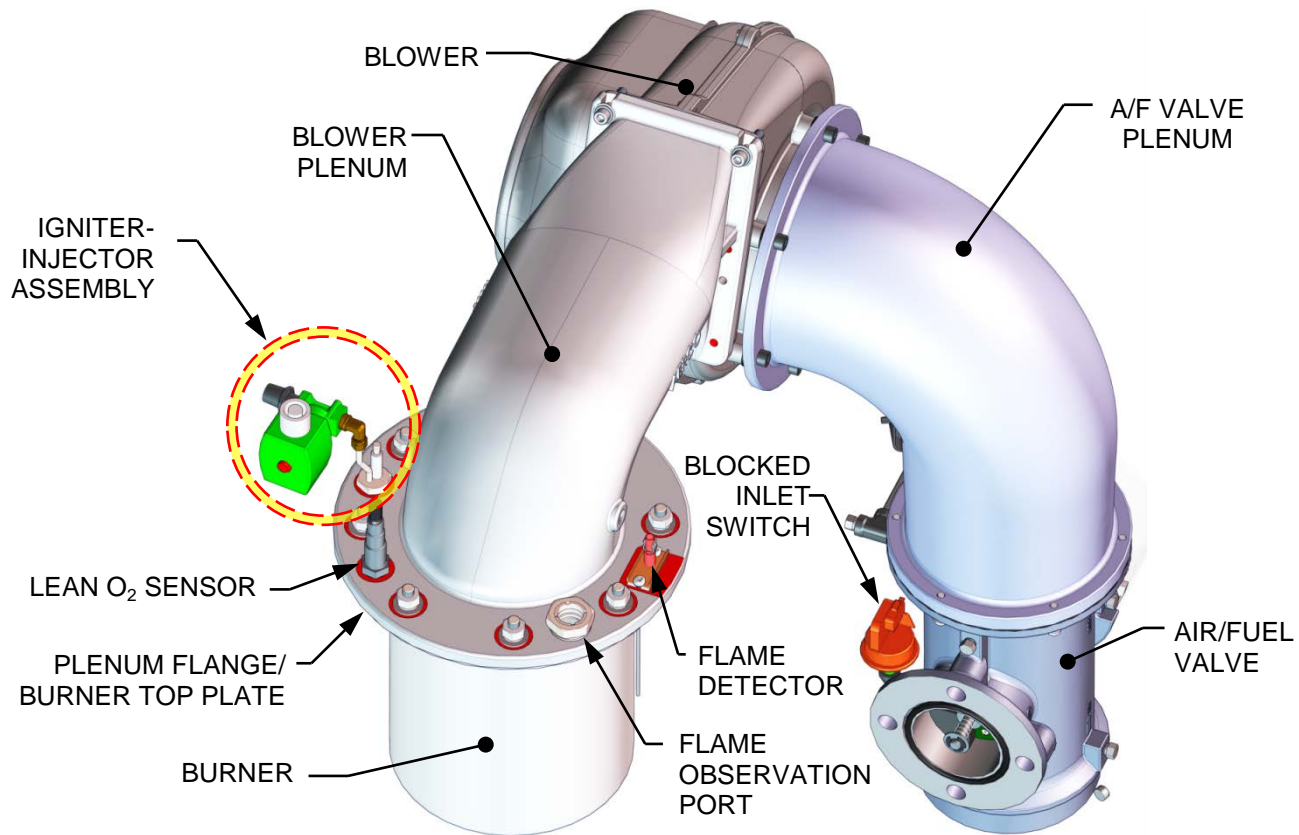

Figure 4-1b: BMK 1500/2000 Burner Assembly (Removed from Boiler)

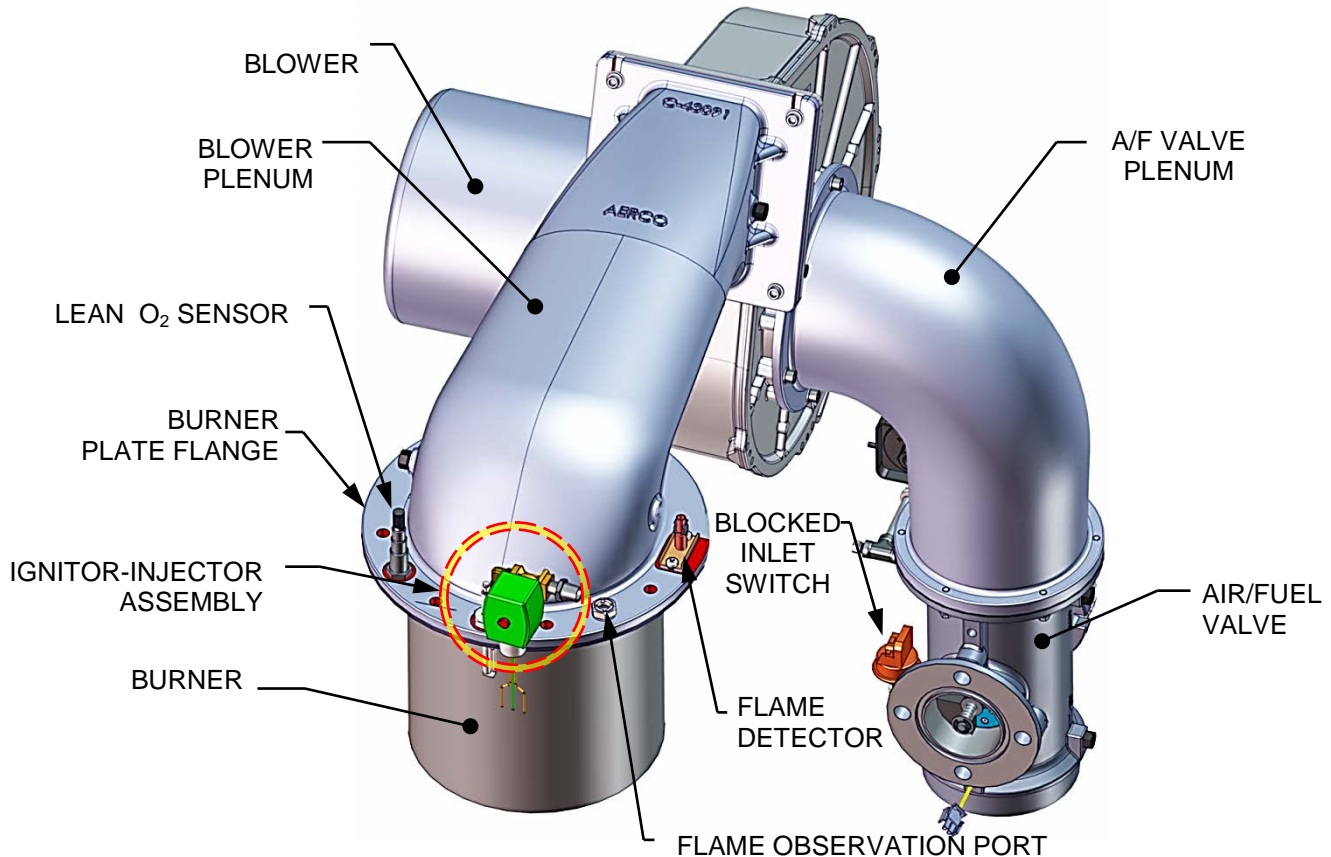

Figure 4-1c: BMK 2500/3000 Burner Assembly (Removed from Boiler)

SECTION 4 – MAINTENANCE

The igniter-injector may be hot, therefore, care should be exercised to avoid burns. It is easier to remove the igniter-injector from the unit after the unit has cooled to room temperature. To inspect/replace the Igniter:

Igniter-Injector Maintenance Procedure Instructions

1. Set the ON/OFF switch on the C-More Controller to the **OFF** position. Disconnect AC power from the unit
2. Remove the top shroud from the unit by grasping the top handle and lifting straight up. This will disengage the shroud from the four (4) pins in the side panels.
3. Disconnect the cable from the igniter-injector (see Figure 4-1a – Figure 4-1c, above).
4. Referring to Figure 4-2a – Figure 4-2c, below, use a 7/16” open-end wrench to disconnect the compression nut securing the gas injector tube of the igniter-injector to the elbow of the staged ignition assembly. Disconnect the staged ignition assembly from the igniter-injector.

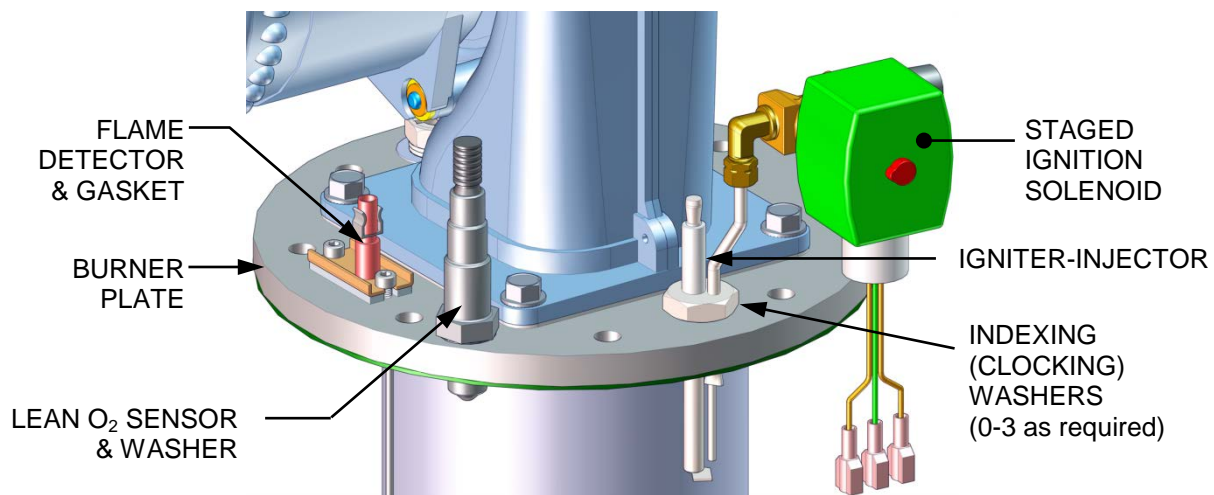

Figure 4-2a: BMK 750/1000 Igniter-Injector & Flame Detector Mounting Details

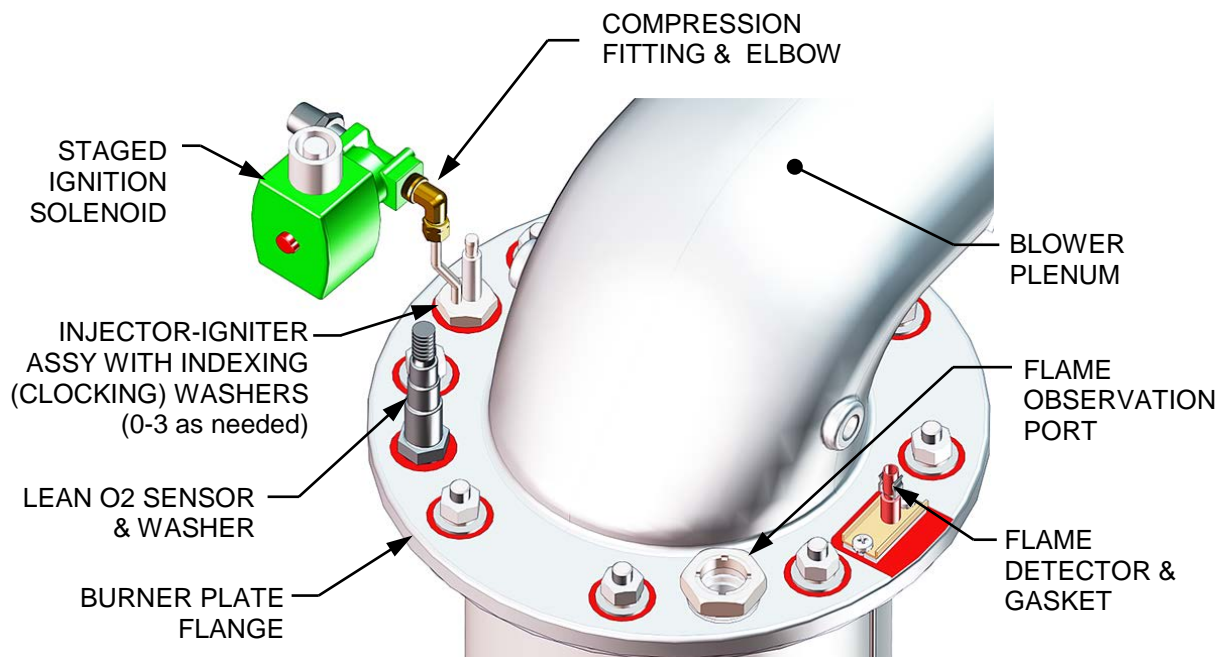

Figure 4-2b: BMK 1500/2000 Igniter-Injector & Flame Detector Mounting Details

Igniter-Injector Maintenance Procedure Instructions

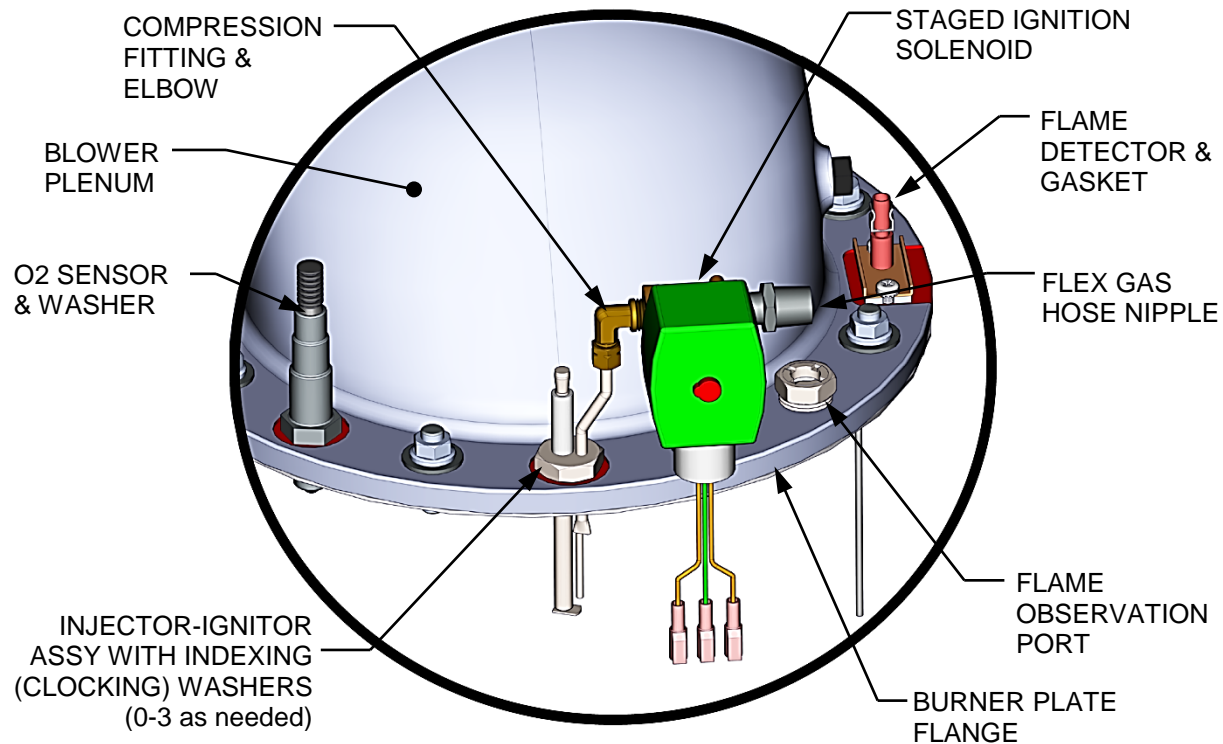

Figure 4-2c: BMK 2500/3000 Igniter-Injector & Flame Detector Mounting Details

5. Next, loosen and remove the igniter-injector from the burner plate using a 1" open-end wrench.
6. Check the igniter-injector for evidence of erosion or carbon build-up. If there is evidence of substantial erosion or carbon build-up, the igniter-injector should be replaced. If carbon build-up is present, clean the component using fine emery cloth. Repeated carbon build-up is an indication that the combustion settings of the unit should be checked. To review combustion calibration procedures, refer to Section 4.4 of the *Benchmark PLATINUM 750–3000 Installation and Startup Guide*, OMM-0115 (GF-200).
7. Prior to reinstalling the igniter-injector, apply a high temperature, conductive, anti-seize compound to the threads.
8. Reinstall the igniter-injector in the burner plate using 1 to 3 indexing washers, as needed, so that when the igniter-injector is tightened, its injector tube will be positioned within the approximately 120° arc shown in Figure 4-3a through Figure 4-3c, below. Note, the recommended injection tube positioning differs for the positioning recommended in the past.
9. Torque the igniter-injector to **170 - 180 in-lbs (19.2 – 20.3 Nm)**. **DO NOT over tighten.**

NOTE:

If replacement igniter-injector (Kit P/N **58023**) is being installed, a compression nut containing a built-in ferrule and 3 indexing washers are included with the kit.

10. Connect the staged ignition assembly to the gas injector tube of the igniter-injector by securing the compression nut to the elbow of the staged ignition assembly.
11. Reconnect the igniter-injector cable.
12. Reinstall the shroud on the unit.

Igniter-Injector Maintenance Procedure Instructions

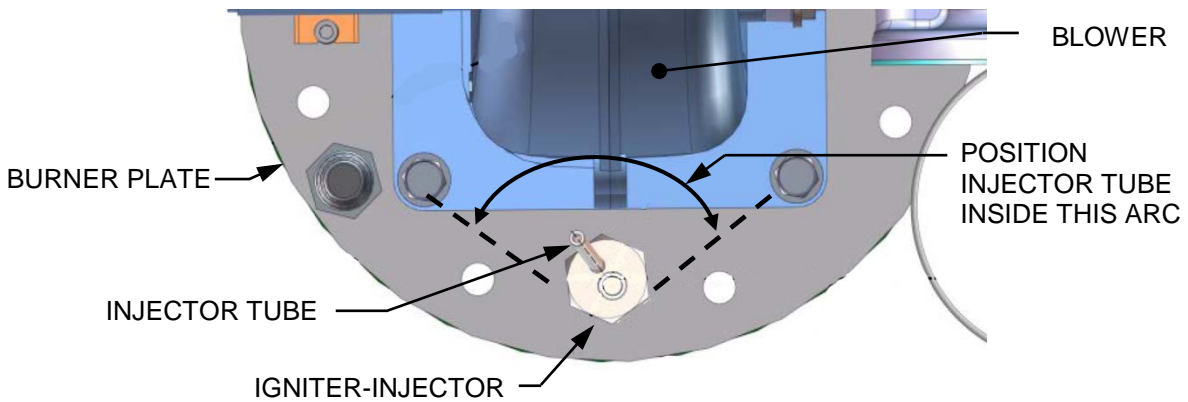

Figure 4-3a: BMK 750/1000 Igniter-Injector Orientation

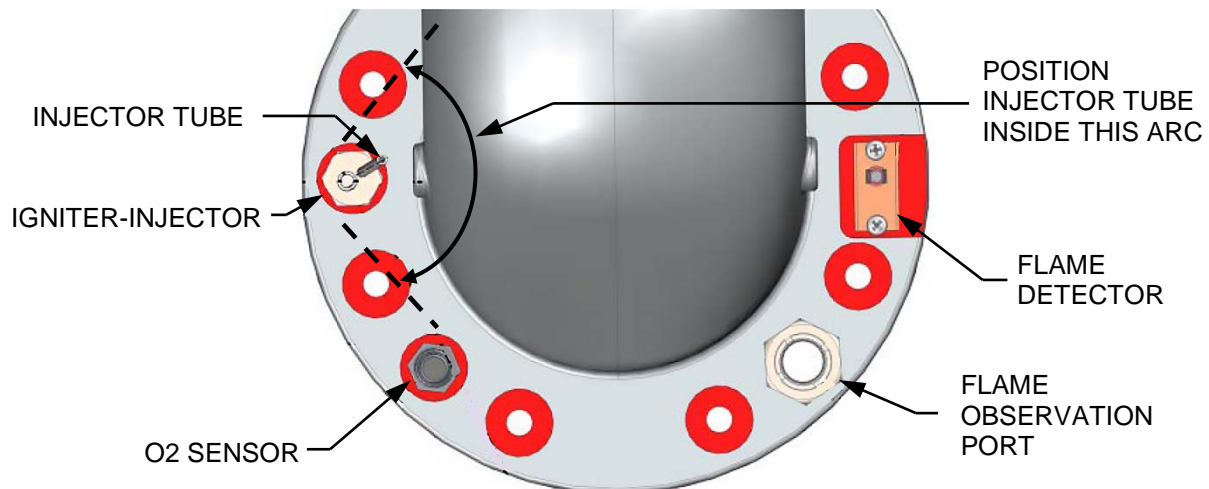

Figure 4-3b: BMK 1500/2000 Igniter-Injector Orientation

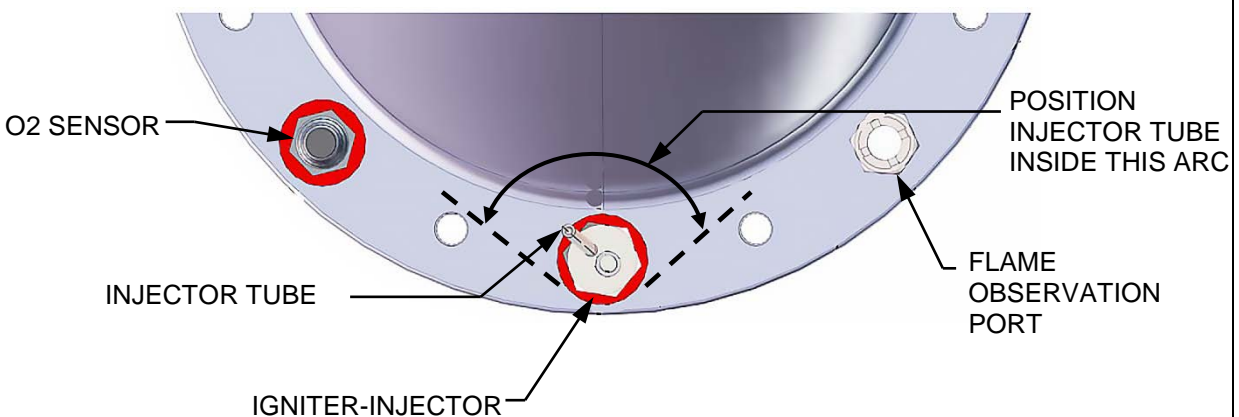

Figure 4-3c. BMK 2500/3000 Igniter-Injector Orientation

4.3 FLAME DETECTOR

The flame detector (kit P/N **24356-1**) is located on the burner plate at the top of the unit (see Figure 4-1a through 4-1c and Figure 4-2a through 4-2c). The flame detector may be hot. Allow the unit to cool sufficiently before removing the flame detector. Inspect or replace the flame detector as follows:

Flame Detector Maintenance Instructions

1. Set the C-More Controller ON/OFF switch to the **OFF** position. Disconnect AC power from the unit.
2. Remove the top shroud from the unit by grasping the top handle and lifting straight up. This will disengage the shroud from the four (4) pins in the side panels.
3. Disconnect the flame detector lead wire.
4. Remove the two (2) screws securing the flame detector to the plate (Figure 4-2a – 4-2c).
5. Remove the flame detector and gasket from the burner plate.
6. Thoroughly inspect the flame detector. If eroded, the detector should be replaced. Otherwise clean the detector with a fine emery cloth.
7. Reinstall the flame detector and flame detector gasket.
8. Reconnect the flame detector lead wire.
9. Reinstall the shroud on the unit.

4.4 O₂ SENSOR

The Lean Oxygen Sensor (P/N **61026**) is located on the burner plate at the top of the unit (see Figure 4-1a through 4-1c and Figure 4-2a through 4-2c). The sensor may be hot. Allow the unit to cool sufficiently before removing or replacing the O₂ sensor.

O₂ Sensor Maintenance Instructions

1. Set the ON/OFF switch on the C-More Controller to the **OFF** position. Disconnect AC power from the unit.
2. Remove the top shroud from the unit by grasping the top handle and lifting straight up. This will disengage the shroud from the four (4) pins in the side panels.
3. Disconnect the O₂ sensor lead wire by pushing in on the release tab and pulling apart the connector.
4. Next, loosen and remove the O₂ sensor and crush washer from the burner plate using a 15/16" open-end wrench.
5. Thoroughly inspect the O₂ sensor. If eroded, the sensor should be replaced. Otherwise clean the sensor with a fine emery cloth.
6. Reinstall the O₂ sensor and crush washer on the burner plate.
7. Reconnect the sensor lead wire.
8. Reinstall the shroud on the unit.

NOTE:

If the AERtrim technology system is functioning, it should be inspected at the same time as O₂ sensor maintenance. See Section 6: *AERtrim Operation*, above, for instructions.

4.5 SAFETY DEVICE TESTING

Systematic and thorough tests of the operating and safety devices should be performed to ensure that they are operating as designed. Certain code requirements, such as ASME CSD-1, require that these tests be performed on a scheduled basis. Test schedules must conform to local jurisdictions. The results of the tests should be recorded in a log book.

See Section 5 of the *Benchmark PLATINUM 750–3000 Installation and Startup Guide*, OMM-0115 (GF-200) for a description and instructions for performing these tests.

4.6 BURNER INSPECTION

The burner assembly is located at the top of the unit's heat exchanger. The burner assembly may be hot. Therefore, allow the unit to cool sufficiently before removing the burner assembly.

The following parts will be required for reassembly after burner inspection:

BMK 750/1000 Burner Inspection Parts	
Part No.	Description
81143	Burner Gasket
81048	Flame Detector Gasket
81064	Blower Gasket

BMK 1500/2000 Burner Inspection Parts	
Part No.	Description
81166	Burner Gasket (1 each)
88183	Burner Release Gasket (1 each)
81186	Burner Lower Release Gasket (1 each)
81048	Flame Detector Gasket (1 each)

BMK 2500/3000 Burner Inspection Parts	
Part No.	Description
88173	Burner Upper Release Gasket
81180	Burner Gasket (Middle)
81185	Burner Lower Release Gasket
81048	Flame Detector Gasket (1 each)

NOTE:
 Illustrations for the burner inspection procedure for all BMK Platinum models are presented first, starting on the next page, followed by the written instructions.

4.6.1 BMK 750/1000 BURNER INSPECTION

BMK 750/1000 Burner Inspection Instructions

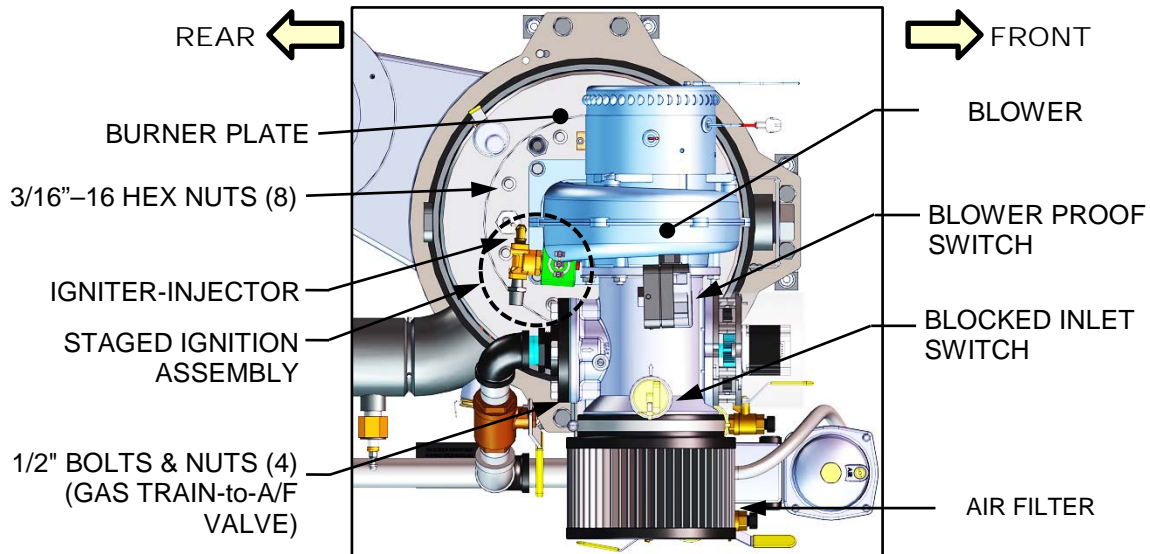

Figure 4-4a: BMK 750/1000 Burner Assembly Mounting Details (Overhead View)

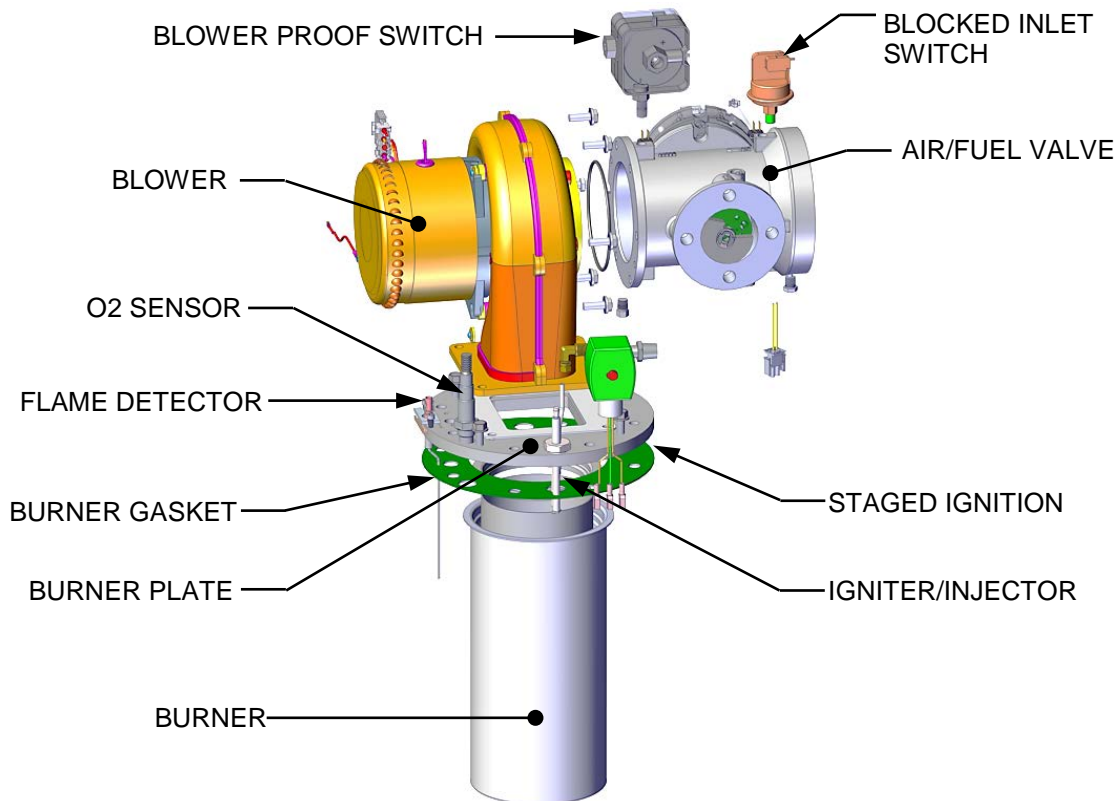

Figure 4-4b: BMK 750/1000 Burner Assembly (Exploded View)

1. Set the ON/OFF switch on the C-More Controller to the **OFF** position. Disconnect AC power from the unit and turn off the gas supply.
2. Remove the top shroud from the unit by grasping the top handle and lifting straight up. This will disengage the shroud from the four (4) pins in the side panels.

BMK 750/1000 Burner Inspection Instructions

3. Disconnect the lead wire from the flame detector installed on the burner plate. See Figure 4-4b.
4. Remove the two (2) screws securing the flame detector to the plate. The flame detector is secured to the burner plate with one (1) #10-32 screw and one (1) #8-32 screw.
5. Remove the flame detector and gasket from the burner plate.
6. Disconnect the cable from the igniter-injector.
7. Using a 7/16" open-end wrench, disconnect the compression nut securing the gas injector tube of the igniter-injector to the elbow of the staged ignition assembly (see Figure 4-1a). Disconnect the staged ignition assembly from the igniter-injector.
8. Next, loosen and remove the igniter-injector from the burner plate using a 1" open-end wrench.
9. Disconnect the unit wiring harness connectors from the air/fuel valve and blower motor.
10. Disconnect the wire leads connected to the Blower Proof switch and Blocked Inlet switch (Figure 4-4a and Figure 4-4b).
11. Disconnect the gas train from the air/fuel valve by removing the four (4) 1/2" bolts and nuts (Figure 4-4a).
12. Disconnect the flex hose from the air/fuel valve by loosening the hose clamp.
13. Remove the four 5/16-18 hex head screws securing the blower to the burner plate (Figure 4-4b).
14. Remove the blower and air/fuel valve from the burner plate by lifting straight up. Also, remove the blower gasket.
15. Remove the eight (8) 3/8-16 nuts from the burner flange (Figure 4-4a) using a 9/16" wrench.

NOTE:

The burner assembly weighs approximately 25 pounds (11.3 kg).

16. Remove the burner assembly from burner flange by pulling straight up.
17. Remove and replace the burner gasket.

NOTE:

During reassembly, apply a light coating of high-temperature, anti-seize lubricant to the threads of the igniter-injector and grounding screw. Also, ensure that the igniter-injector is properly positioned as indicated in Figure 4-3a. Torque the igniter-injector to **14 - 15 ft-lbs. (19.0 - 20.3 Nm)**.

18. Beginning with the burner assembly removed in step 16, reinstall all the components in the reverse order that they were removed. When reinstalling the burner flange (removed in step 15), tighten the 3/8-16 nuts using a typical torque pattern. For example, loosely tighten one nut, then loosely tighten a second nut on the opposite side, a third at 90 degrees to the first two, and a fourth opposite the third, and then repeat this pattern with the remaining four nuts. Repeat the entire pattern a second time to partially tighten all eight nuts, and then repeat a third time until all eight nuts are fully torqued to 30 ft. lbs. (40.7 Nm).
19. Ensure that the igniter-injector and flame detector cutouts in the burner plate are properly aligned with the heat exchanger top flange.

This completes the Benchmark 750/1000 burner inspection.

4.6.2 BMK 1500 – 3000 BURNER INSPECTION

BMK 1500-3000 Burner Inspection Instructions

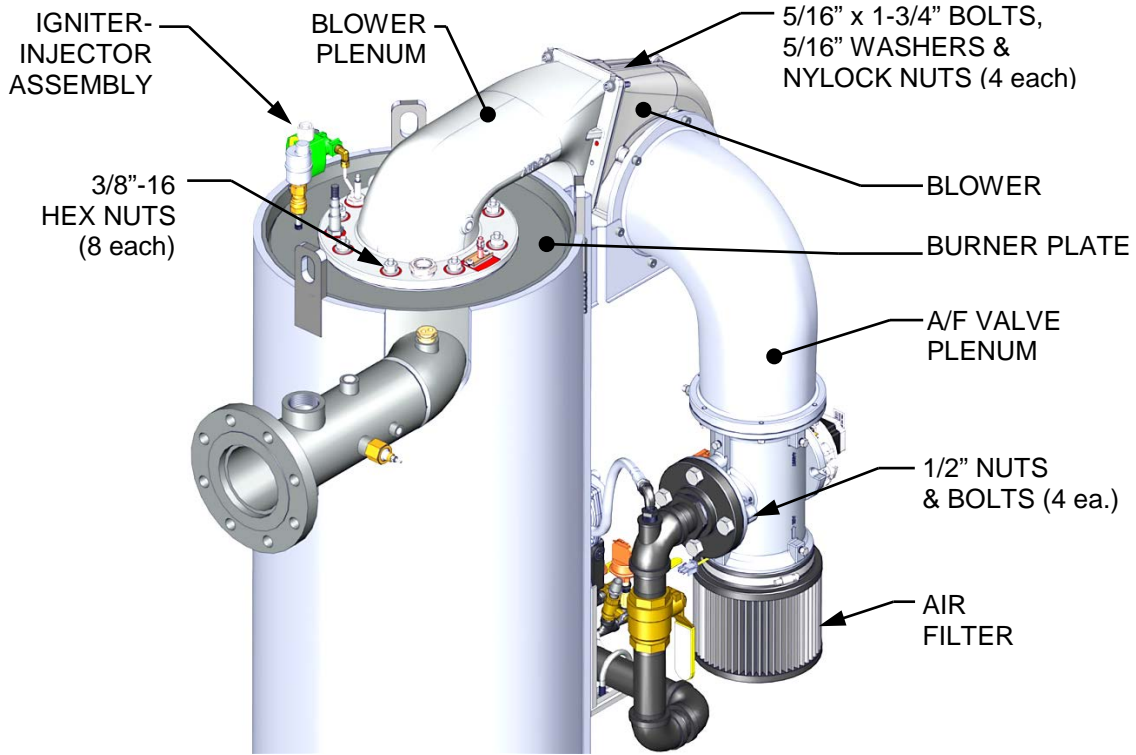

Figure 4-5a: BMK 1500/2000 Burner Assembly Mounting Details

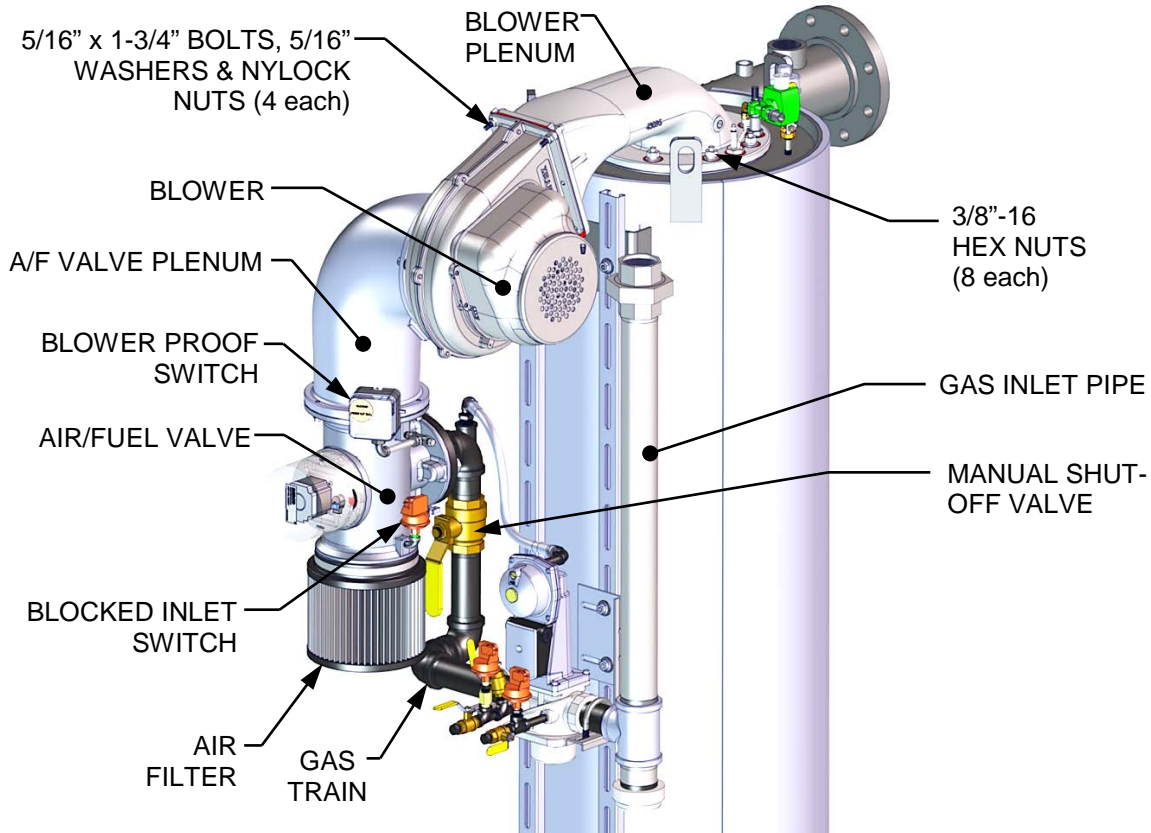

Figure 4-5b: BMK 1500/2000 Burner Assembly Mounting Details

BMK 1500-3000 Burner Inspection Instructions

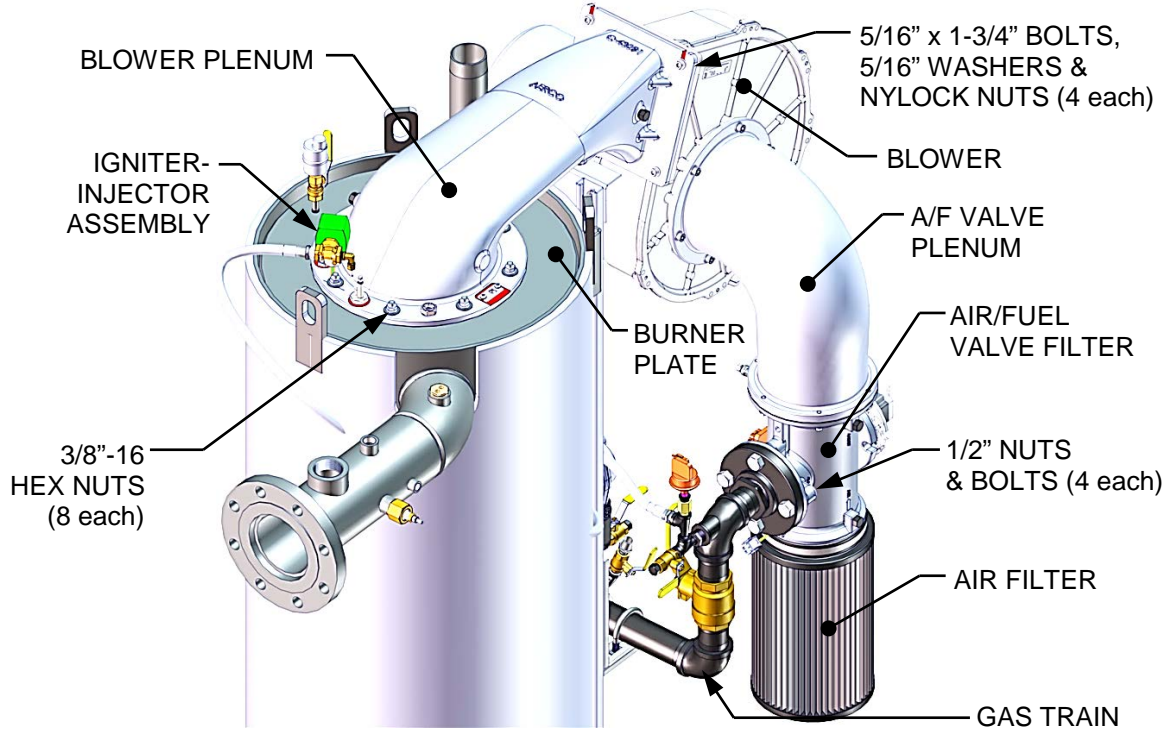

Figure 4-5c: BMK 2500/3000 Burner Assembly Mounting Details

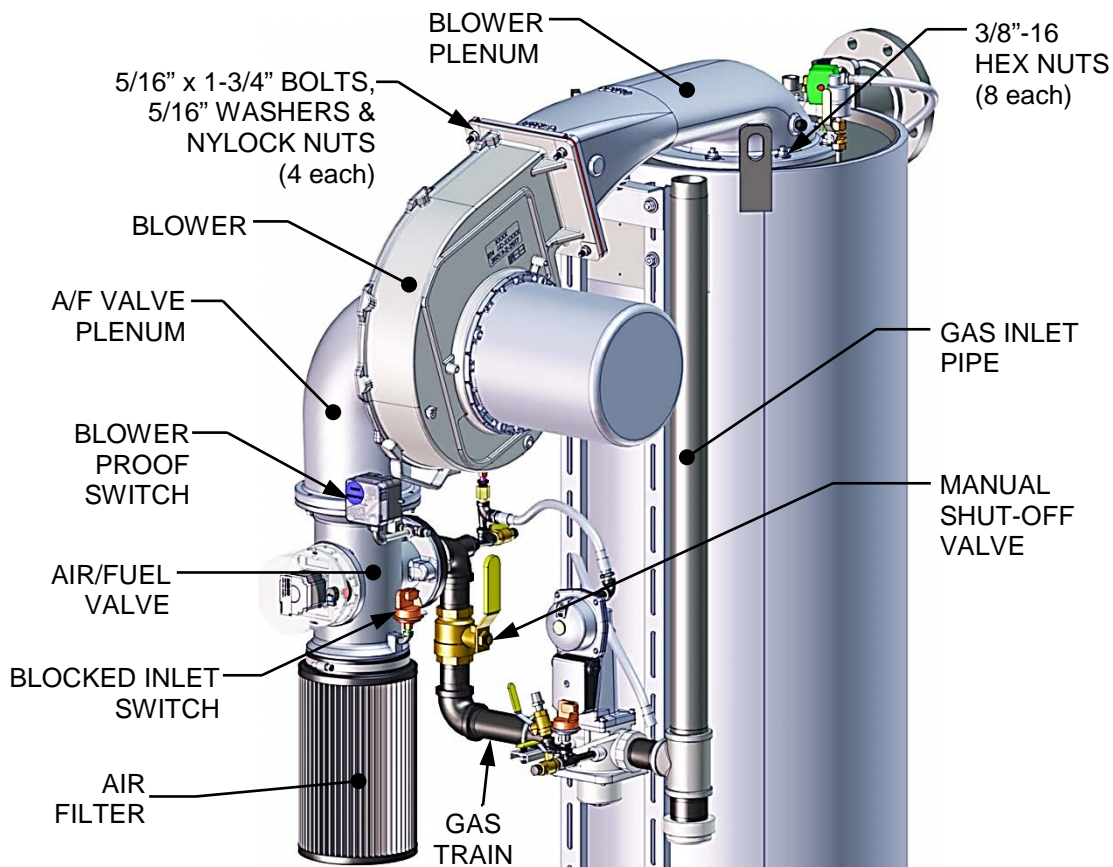

Figure 4-5d: BMK 2500/3000 Burner Assembly Mounting Details

BMK 1500-3000 Burner Inspection Instructions

1. Set the ON/OFF switch on the C-More Controller to the **OFF** position. Disconnect AC power from the unit and turn off the gas supply.
2. Remove the top shroud from the unit by grasping the top handle and lifting straight up. This will disengage the shroud from the four (4) pins in the side panels.
3. Disconnect the lead wire from the flame detector installed on the burner plate. See Figure 4-2b (BMK 1500/2000) or Figure 4-2c (BMK 2500/3000).
4. Remove the two (2) screws securing the flame detector to the plate. The flame detector is secured to the burner plate with one (1) #10-32 screw and one (1) #8-32 screw.
5. Remove the flame detector and gasket from the burner plate.
6. Disconnect the cable from the igniter-injector.
7. Using a 7/16" open-end wrench, disconnect the compression nut securing the gas injector tube of the igniter-injector to the elbow of the staged ignition assembly (see Figure 4-2b (BMK 1500/2000) or Figure 4-2c (BMK 2500/3000). Disconnect the staged ignition assembly from the igniter-injector.
8. Next, loosen and remove the igniter-injector from the burner plate using a 1" open-end wrench.
9. Loosen and remove the four 5/16 x 1-3/4" bolts, washers, and nuts from the blower plenum where it attaches to the blower. See Figure 4-5a & 4-5b (BMK 1500/2000) or Figure 4-5c & 4-5d (BMK 2500/3000).
10. You must either rig a support for the blower to hold it in place or remove the blower from the unit and set it aside for later reassembly.
11. Remove the eight (8) 3/8-16 nuts, using a 9/16" wrench, attaching the blower plenum to the burner. See Figure 4-5a & 4-5b (BMK 1500/2000) or Figure 4-5c & 4-5d (BMK 2500/3000).
12. Remove the blower plenum from between the blower and the burner and set it aside for later reassembly. The O₂ sensor and flame observation port remain assembled to the plenum flange.
13. Remove the burner by pulling straight up.

NOTE:

The burner assembly weighs approximately 65 lbs. (29.5 kg).

14. Remove and replace the burner gasket(s) (see Figure 4-6, below).

IMPORTANT!

ALL THREE gaskets provided for maintenance **MUST** be installed during this procedure, as shown in Figure 4-6, even if there is only one existing gasket being replaced. Note that the **LOWER RELEASE GASKET** has tabs, which the others do not.

NOTE:

During reassembly, apply a light coating of high-temperature, anti-seize lubricant to the threads of the igniter-injector and grounding screw. Also, ensure that the igniter-injector is properly positioned as indicated in Figure 4-3b or Figure 4-3c. Torque the igniter-injector to **14 - 15 ft.-lbs. (19.0 - 20.3 Nm)**.

(Continued)

BMK 1500-3000 Burner Inspection Instructions

NOTE:

The LOWER RELEASE GASKET (P/N 81186) features four tabs around its periphery.

IMPORTANT!

Use ALL THREE gaskets provided, even if there is only one existing gasket being replaced.

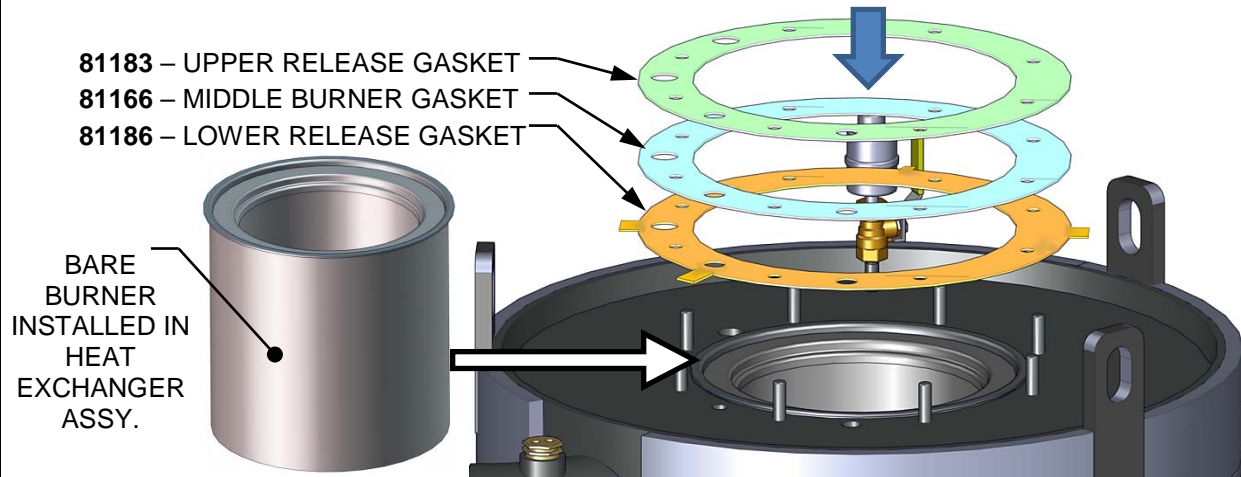

Figure 4-6: Bare Burner and Replacement Gaskets Location

15. Beginning with the burner assembly, reinstall all the components in the reverse order that they were removed. When reinstalling the blower plenum (removed in step 11), tighten the 3/8-16 nuts using a typical torque pattern (for example, loosely tighten one nut, then loosely tighten a second nut on the opposite side, a third at 90 degrees to the first two, and a fourth opposite the third, and then repeat this pattern with the remaining four nuts. Repeat the entire pattern a second time to partially tighten all eight nuts, and then repeat a third time until all eight nuts are fully torqued to 35 ft. lbs. (47.5 Nm).
16. Ensure that the igniter-injector and flame detector cutouts in the burner plate are properly aligned with the heat exchanger top flange.

This completes the Benchmark 1500/3000 burner inspection.

4.7 CONDENSATE DRAIN TRAP

Benchmark boilers contain a condensate trap (P/N **24441**), located external to the unit and attached to the drain connection from the exhaust manifold at the rear of the unit (shown in Figure 2-6a and 2-6b of the *Benchmark PLATINUM 750–3000 Installation and Startup Guide*, OMM-0115 (GF-200)). This trap should be inspected and cleaned in accordance with the maintenance schedule shown in Table 4-1, above, to ensure proper operation.

To inspect and clean the trap, proceed as follows:

Condensate Drain Trap Maintenance Instructions

1. Disconnect the external condensate trap by loosening and then removing connections on the inlet and outlet sides of the condensate trap (see Figure 4-7).
2. Loosen the four (4) thumbscrews securing the trap's cover and then remove the cover and the O-ring from under the cover.
3. Remove the float and then thoroughly clean the trap and float. Also inspect the drain piping for blockage. If the trap cannot be thoroughly cleaned, replace the entire trap (P/N **24441**).
4. Replace the float, install the O-ring (P/N **84017**), and then replace the trap cover.
5. Reassemble all piping and hose connections to the condensate trap inlet and outlet.

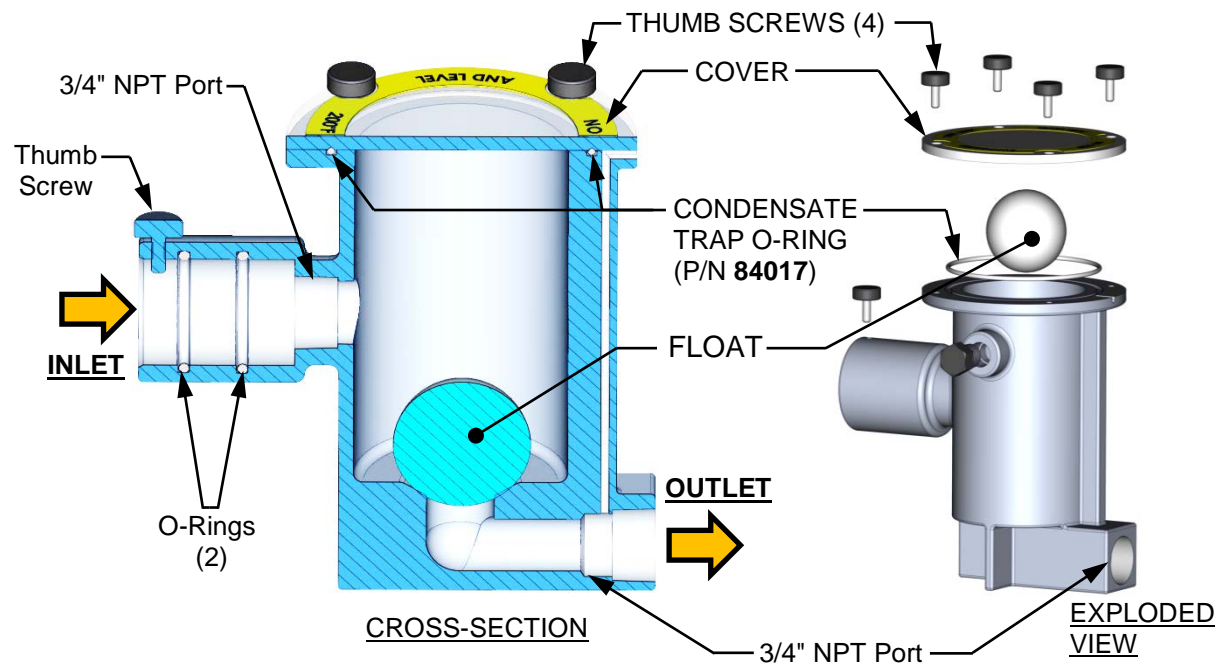

Figure 4-7: External Condensate Trap – Cross-Section & Exploded View

4.8 AIR FILTER CLEANING and REPLACEMENT

The Benchmark boiler is equipped with an air filter which should be cleaned and re-oiled every 12 months and replaced every 24 months. The air filter is located at the air fuel valve inlet, as shown in Figure 4-8.

TABLE 4-2: Available Air Filters	
Benchmark Model	Part Number
750, 1000	59139
1500, 2000	59138
2500, 3000	88014

To inspect/replace the air filter, proceed as follows:

Air Filter Cleaning and Replacement Instructions

1. Set the ON/OFF switch on the C-More Controller to the **OFF** position. Disconnect AC power from the unit.
2. Remove the top shroud from the unit by grasping the top handle and lifting straight up. This will disengage the shroud from the four (4) pins in the side panels.
3. Refer to Figure 4-8 and locate the air filter attached to the air/fuel valve inlet.

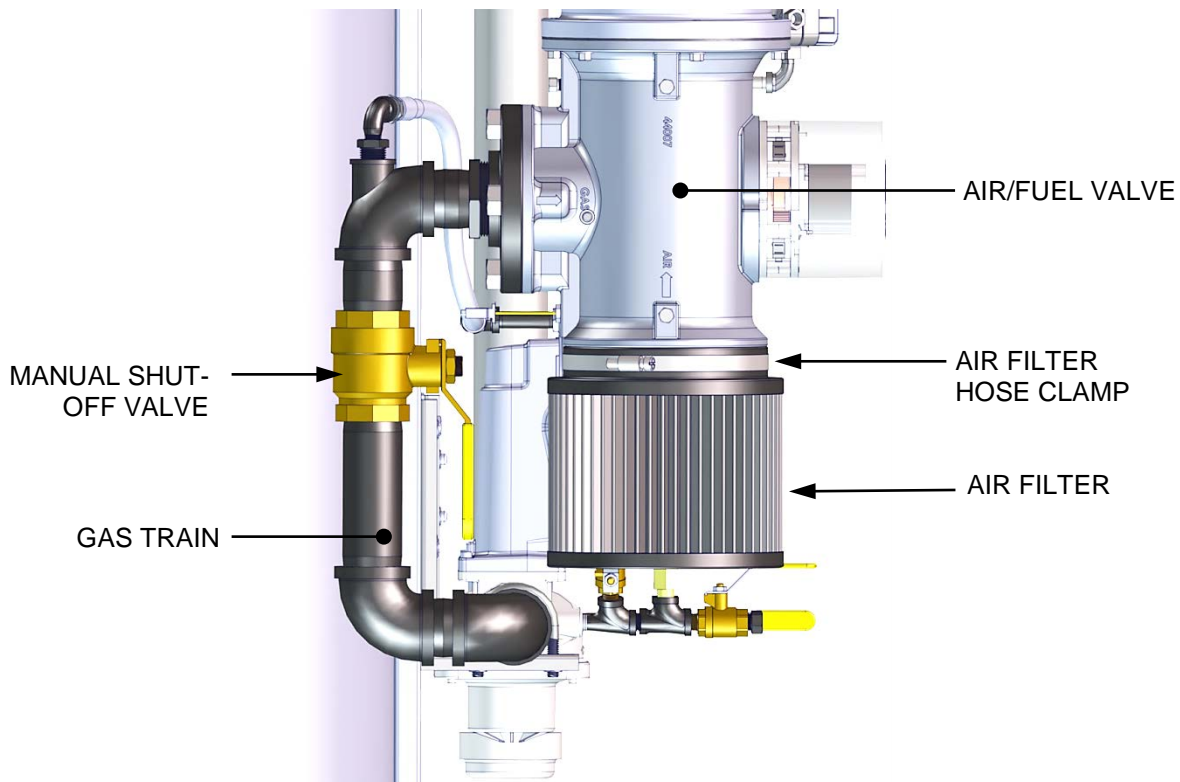

Figure 4-8: Air Filter Location (BMK 1500/2000 Shown)

4. Using a flat-tip screwdriver or 5/16" nut driver, loosen the clamp securing the filter to the inlet flange of the air/fuel valve. Remove the filter and clamp.

Air Filter Cleaning and Replacement Instructions

5. The filter may be cleaned in hot soapy water to remove oil and dirt. It should then be thoroughly dried and then sprayed with a light coating of K&N® Air Filter Oil (or equivalent specifically formulated for air filters) prior to reinstallation. **Do NOT use WD-40.**
6. Each replacement air filter is equipped with its own clamp. Therefore, simply install the replacement air filter on inlet flange of the air fuel valve and tighten the clamp with a flat-tip screwdriver or 5/16" nut driver.
7. Replace the top shroud on the unit and return boiler to service use.

4.9 WATER CUTOFF (LWCO) CAPACITOR INTEGRITY TEST

The LWCO capacitor (FRU Kit P/N **69126**) should be tested for electrical shorts every 12 months and replaced, then tested, every 24 months. The LWCO capacitor integrity test consists of two parts as described in the next two sections. The first procedure explains how to test for electrical shorting of the LWCO probe capacitor, while the second procedure instructs how to perform the standard Low Water Cutoff test using the C-More controls.

Refer to Figure 4-9 for an illustration of the LWCO probe assembly and its typical installation.

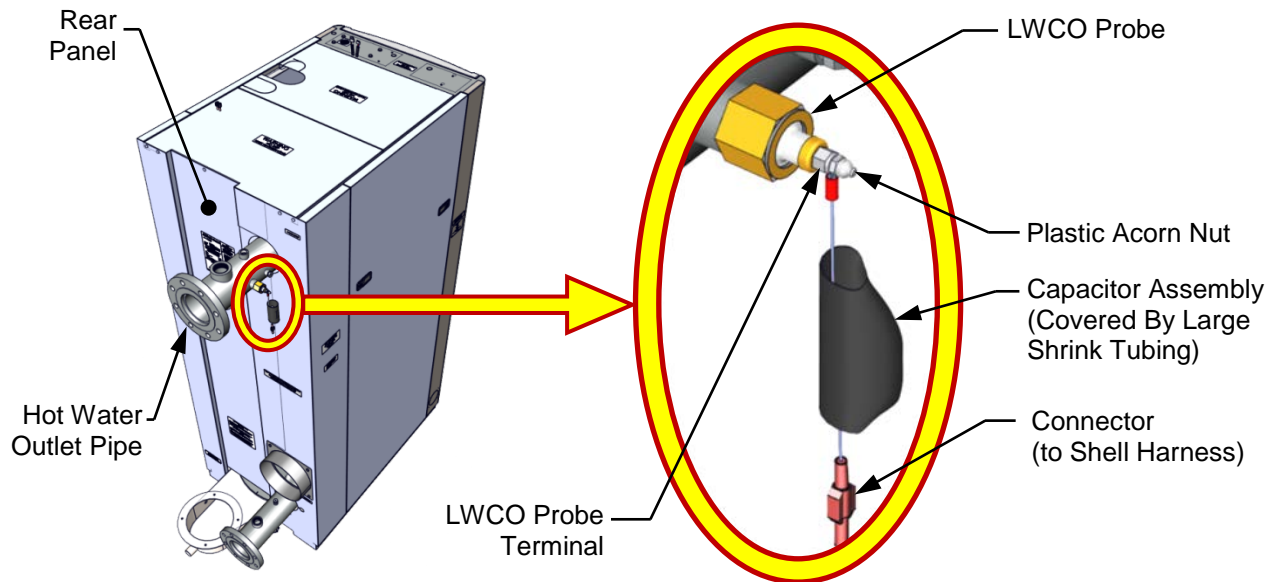

Figure 4-9: LWCO Probe Location (BMK1500 Shown)

4.9.1 Low Water Cutoff (LWCO) - Capacitor Electrical Short Test

This test determines if there is an electrical short between the LWCO capacitor and the heat exchanger. Perform the capacitor electrical short test as described below.

Low Water Cutoff – Capacitor Electrical Short Test Instructions

1. Turn the AC power to the unit to OFF.

WARNING!
 High voltages are used to power these units and so it is required that power applied to these units is removed first before performing the procedure described in this instruction. Serious personal injury or death may occur if this warning is not observed.

2. Remove the Shell Harness Cable (male) connector from the P-5 (female) connector on the rear panel of the C-More controller (see Figure 4-10).

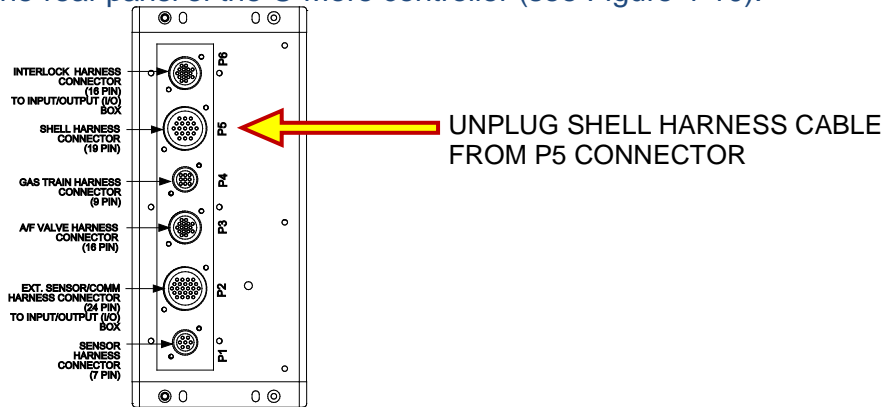

Figure 4-10: Removing Shell Harness Cable from P5 Conn. on C-More Rear Panel

3. Using an ohmmeter, connect one ohmmeter probe to the LWCO capacitor terminal on the unit shell as shown on left in Figure 4-11.
4. Connect the second ohmmeter probe to Pin #6 of Shell Harness Connector (removed from the C-More controller) as shown on right in Figure 4-11.

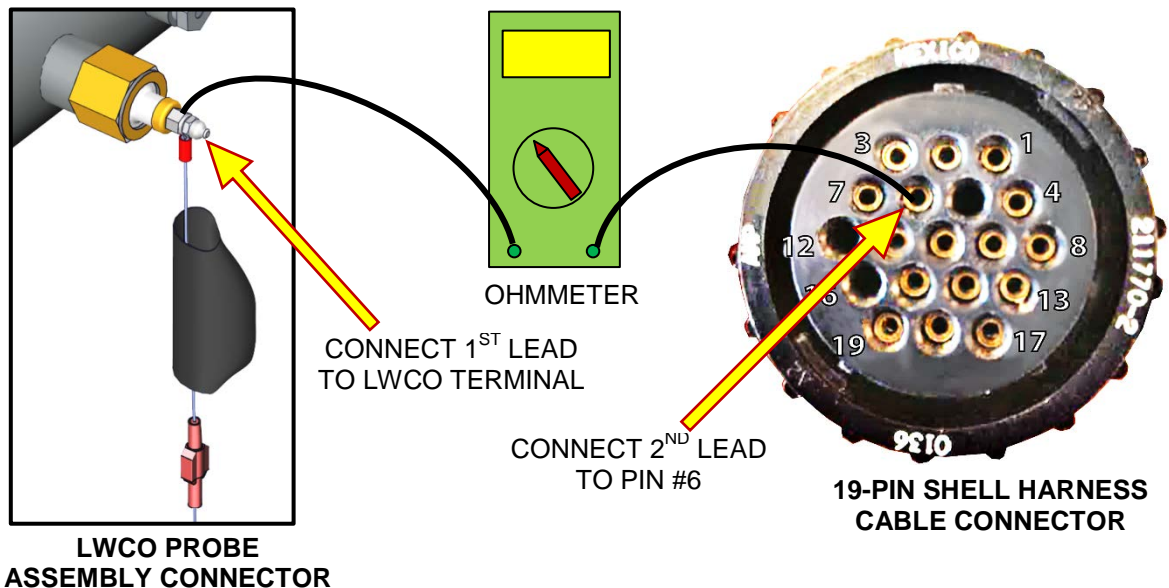

Figure 4-11: Connecting Ohmmeter between LWCO Probe & Shell Harness Cable

4.9.2 Low Water Cutoff (LWCO) - Standard C-More Test

Perform the standard Low Water Cutoff test using the C-More controls as described below.

Low Water Cutoff (LWCO) - Standard C-More Test Instructions

1. Turn the AC power to the unit to the **ON** position.
2. Press the TEST switch on the C-More controller and confirm that the blinking *LOW WATER LEVEL* message appears on the C-More display within 4 seconds.
3. Press the RESET key, followed by the Clear button, and confirm that the *LOW WATER LEVEL* message is cleared.

4.10 SHUTTING BOILER DOWN FOR EXTENDED PERIOD

If the boiler is to be taken out of service for an extended period of time (one year or more), the following instructions must be followed.

Shutting Boiler Down For An Extended Period Instructions

1. Set ON/OFF switch on the front panel to the OFF position to shut down the boiler's operating controls.
2. Disconnect AC power from the unit.
3. Close the water supply and return valves to isolate boiler.
4. Close external gas supply valve.
5. Open relief valve to vent water pressure.
6. Open the drain valve and drain all water from the unit.
7. If the temperature in the storage location will ever get below freezing, **for even a short time**, you must drain **all** water from the unit **before** the temperature falls below freezing. Step 6 is not sufficient, as it leaves some water in the bottom of the heat exchanger chamber. You must then use a suction pump inserted through the inspection ports to remove all water from the bottoms of the heat exchanger chamber and base assembly.

WARNING!

If the temperature will ever fall below freezing, failure to drain **all** water can cause heat exchanger tubes to crack and fail.

4.11 PLACING THE BOILER BACK IN SERVICE AFTER A PROLONGED SHUTDOWN

After a prolonged shutdown (one year or more), the following procedures must be followed:

Placing The Boiler Back In Service After A Prolonged Shutdown Instructions

1. Review installation requirements included in Section 2 of the *Benchmark PLATINUM 750–3000 Installation and Startup Guide*, OMM-0115 (GF-200).
2. Inspect all piping and connections to the unit.
3. Inspect exhaust vent and air inlet duct work (if applicable).
4. Perform initial startup per Section 4 of the *Benchmark PLATINUM 750–3000 Installation and Startup Guide*, OMM-0115 (GF-200).
5. Perform safety device testing and scheduled maintenance procedures per Sections 5 and 6 of this manual.

4.12 SPARK MONITOR (AC CURRENT TRANSDUCER)

The spark monitor (P/N 61034) evaluates the strength of the current between the ignition transformer and igniter-injector. Wire# 140, connected to the ignition transformer (see Figure 4-12), passes through the monitor's orifice. If an adequate AC current is not detected in the wire during ignition, the unit automatically shuts down. The monitor's wires are connected to the I/O board's Spark Signal terminals (see section 2.11.4 in the *Benchmark PLATINUM 750–3000 Installation and Startup Guide*, OMM-0115 (GF-200) for details).

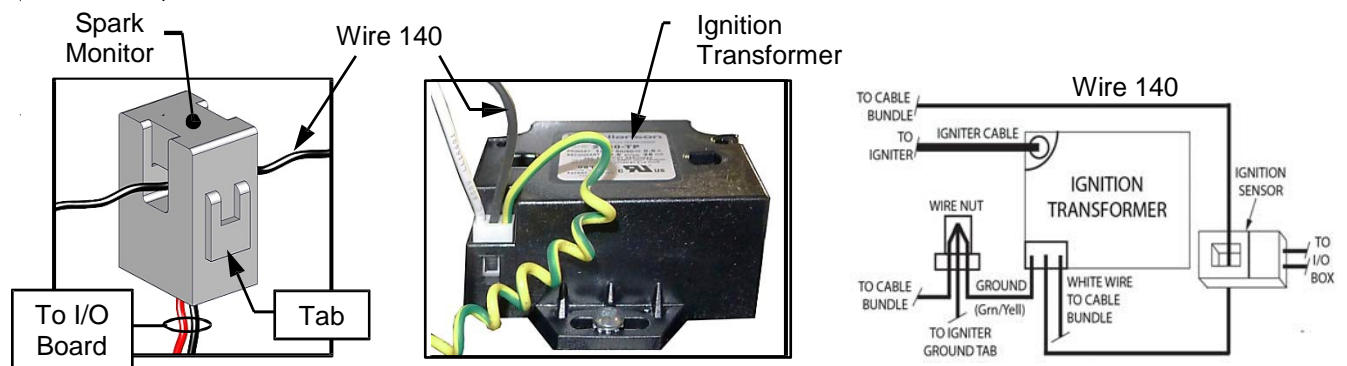

Figure 4-12: Spark Detector Sensor (AC Current Transducer) P/N 61034

If the spark monitor needs to be replaced, open the monitor's orifice by pulling on the tab at the side, remove Wire# 140, disconnect the monitor's wires from the I/O board, remove the old monitor from its position, install a new monitor in its place, route wire# 140 through the new sensor orifice, and connect the wires to the I/O board's Spark Signal terminals, red wire to the positive (+) terminal and black to negative (-).

SECTION 5: TROUBLESHOOTING GUIDE

5.1 INTRODUCTION

This troubleshooting guide is intended to aid service/maintenance personnel in isolating the cause of a fault in Benchmark 750 through 3000 boilers. The troubleshooting procedures contained herein are presented in tabular form on the following pages. These tables are comprised of three columns labeled: Fault Indication, Probable Cause and Corrective Action. The numbered items in the Probable Cause and Corrective Action columns correspond to each other. For example, Probable Cause No. 1 corresponds to Corrective Action No. 1, etc.

When a fault occurs in the unit, proceed as follows to isolate and correct the fault:

Fault Correction Instructions

1. Observe the fault messages displayed in the C-More Controller display.
2. Refer to the Fault Indication column in Troubleshooting Table 5-1 which follows and locate the Fault that best describes the existing conditions.
3. Proceed to the Probable Cause column and start with the first item (1) listed for the Fault Indication.
4. Perform the checks and procedures listed in the Corrective Action column for the first Probable Cause candidate.
5. Continue checking each additional Probable Cause for the existing fault until the fault is corrected.
6. Section 6-2 contains additional troubleshooting information which may apply when a no fault message is displayed.

If the fault cannot be corrected using the information provided in the Troubleshooting Tables, contact your local AERCO Representative.

NOTE:

The front panel of the C-More Controller contains an RS232 port. This port is used only by factory-trained personnel to monitor onAER communications via a portable computer.

(This page intentionally blank)

TABLE 5-1: Boiler Troubleshooting Procedures

Fault Indication	Probable Causes	Corrective Action
<p>AIRFLOW FAULT DURING IGNITION</p>	<ol style="list-style-type: none"> 1. Blower stopped running due to thermal or current overload. 2. Blocked Blower inlet or inlet air filter. 3. Blockage in Blower Proof switch. 4. Blockage in Blocked Inlet switch. 5. Defective Blower Proof switch. 6. Defective Blocked Inlet switch. 7. Loose temperature to AUX connection in I/O Box. 8. Defective temperature sensor. 9. Loose wire connection between the 0-10V signal from I/O box to the Blower input. 10. Defective I/O Box. 11. Wrong 0-10V output selection on the C-More Controller. 12. Defective Air-Fuel Valve potentiometer. 13. Hard light. 	<ol style="list-style-type: none"> 1. Check combustion blower for signs of excessive heat or high current drain that may trip thermal or current overload devices. 2. Inspect the inlet to the combustion blower including the air filter at the air/fuel valve for signs of blockage. 3. Remove the Blower Proof switch and inspect for signs of blockage, clean or replace as necessary. 4. Remove the Blocked Inlet switch and inspect for signs of blockage, clean or replace as necessary. 5. Check the continuity of the Blower Proof switch with the combustion blower running. If there is an erratic resistance reading or the resistance reading is greater than zero ohms, replace the switch. 6. Turn off unit and check the continuity of the Blocked Inlet switch. If there is an erratic resistance reading or the resistance reading is greater than zero ohms, replace the switch. 7. Check the actual inlet air temperature and measure voltage at AUX input in the I/O Box. Verify that the voltage conforms to the values shown in Appendix C. 8. Refer to CORRECTIVE ACTION 7 and verify that the voltage conforms to the values shown in Appendix C. 9. Check wire connection from I/O Box 0-10V signal to the Blower Motor. 10. Measure voltage at the I/O box 0-10V output. A voltage of 10V equates to a 100% open valve position. 11. Check the <i>Analog Out</i> option on the C-More <i>Configuration</i> menu. Valve Position 0-10V should be selected. 12. Check Air/Fuel Valve position at 0%, 50% and 100% open positions. The positions on the VALVE POSITION bargraph should match the readings on the Air/Fuel Valve dial. 13. Check igniter-injector for soot or erosion of electrode. Check injector solenoid valve to insure proper open/close operation.

SECTION 5 – TROUBLESHOOTING GUIDE

TABLE 5-1: Boiler Troubleshooting Procedures

Fault Indication	Probable Causes	Corrective Action
AIRFLOW FAULT DURING PURGE	<ol style="list-style-type: none"> 1. Blower not running or running too slow. 2. Defective Blocked Inlet switch. 3. Blockage in air filter or Blocked Inlet switch. 4. Blocked blower inlet or inlet ductwork. 5. No voltage to Blocked Inlet switch from C-More Controller. 6. PROBABLE CAUSES from 3 to 12 for AIRFLOW FAULT DURING IGNITION apply for this fault. 	<ol style="list-style-type: none"> 1. Start the unit. If the blower does not run check the blower solid state relay for input and output voltage. If the relay is OK, check the blower. 2. Start the unit. If the blower runs, turn off unit and check the Blocked Inlet switch for continuity. Replace the switch if continuity does not exist. 3. Remove the air filter and Blocked Inlet switch and inspect for signs of blockage. Clean or replace as necessary. 4. Inspect the inlet to the combustion blower including any ductwork leading up to the combustion blower for signs of blockage. 5. During the start sequence, verify that 24 VAC is present between each side of the switch and ground. If 24 VAC is not present, refer fault to qualified service personnel. 6. See CORRECTIVE ACTIONS from 3 to 12 for AIRFLOW FAULT DURING IGNITION.
AIRFLOW FAULT DURING RUN	<ol style="list-style-type: none"> 1. Blower stopped running due to thermal or current overload. 2. Blocked Blower inlet or inlet ductwork. 3. Blockage in air filter or Blocked Inlet switch. 4. Defective Blocked Inlet switch. 5. Combustion oscillations. 6. Probable causes from 3 to 16 for AIRFLOW FAULT DURING IGNITION applies for this fault. 	<ol style="list-style-type: none"> 1. Check combustion blower for signs of excessive heat or high current draw that may trip thermal or current overload devices. 2. Inspect the inlet to the combustion blower, including any ductwork leading up to the combustion blower, for signs of blockage. 3. Remove the air filter and Blocked Inlet switch and inspect for signs of blockage, clean or replace as necessary. 4. Verify that 24 VAC is present between each side of the switch and ground. If 24 VAC is not present at both sides, replace switch. 5. Run unit to full fire. If the unit rumbles or runs rough, perform combustion calibration. 6. See CORRECTIVE ACTIONS from 3 to 12 for AIRFLOW FAULT DURING IGNITION.

TABLE 5-1: Boiler Troubleshooting Procedures

Fault Indication	Probable Causes	Corrective Action
DELAYED INTERLOCK OPEN	<ol style="list-style-type: none"> 1. Delayed Interlock Jumper not properly installed or missing. 2. Device proving switch hooked to interlocks is not closed. 	<ol style="list-style-type: none"> 1. Check to insure jumper is properly installed across the delayed interlock terminals in the I/O Box. 2. If there are 2 external wires on these terminals, check to see if an end switch for a proving device (such as a pump, louver, etc.) is tied these interlocks. Ensure that the device and/or its end switch is functional. A jumper may be temporarily installed to test the interlock.
DIRECT DRIVE SIGNAL FAULT	<ol style="list-style-type: none"> 1. Direct drive signal is not present: <ul style="list-style-type: none"> --Not yet installed. --Wrong polarity. --Signal defective at source. --Broken or loose wiring. 2. Signal is not isolated (floating). 3. C-More Controller signal type selection switches not set for correct signal type (voltage or current). 	<ol style="list-style-type: none"> 1. Check I/O Box to ensure signal is hooked up. <ul style="list-style-type: none"> --Hook up if not installed. --If installed, check polarity. --Measure signal level. --Check wiring continuity between source and unit. 2. Check signal at source to ensure it is isolated. 3. Check DIP switch on PMC board to ensure it is set correctly for the type of signal being sent. Check control signal type set in <i>Configuration</i> menu.
FLAME LOSS DURING IGN	<ol style="list-style-type: none"> 1. Worn Flame Detector. 2. No spark from Spark Igniter. 3. Defective Ignition Transformer. 4. Defective Ignition/Stepper (IGST) Board. 5. Defective SSOV. 	<ol style="list-style-type: none"> 1. Remove and inspect the Flame Detector for signs of wear. Replace if necessary. 2. Close the internal gas valve in the unit. Install and arc a spark igniter outside the unit. 3. If there is no spark, check for 120VAC at the primary side to the ignition transformer during the ignition cycle. 4. If 120VAC is not present, the IGST Board in the C-More Controller may be defective. Refer fault to qualified service personnel. 5. While externally arcing the spark igniter, observe the open/close indicator in the Safety Shut-Off Valve to ensure it is opening. If the valve does not open, check for 120VAC at the valve input terminals. If 120VAC is not present, the IGST board in the C-More Controller may be defective. Refer fault to qualified service personnel.

SECTION 5 – TROUBLESHOOTING GUIDE

TABLE 5-1: Boiler Troubleshooting Procedures

Fault Indication	Probable Causes	Corrective Action
FLAME LOSS DURING RUN	<ol style="list-style-type: none"> 1. Worn Flame Detector or cracked ceramic. 2. Defective Regulator. 3. Poor combustion calibration. 4. Debris on burner. 5. Blocked condensate drain. 	<ol style="list-style-type: none"> 1. Remove and inspect the Flame Detector for signs of wear or cracked ceramic. Replace if necessary. 2. Check gas pressure readings using a gauge or manometer into and out of the Air/Fuel Valve to ensure that the gas pressure into and out of the valve is correct. 3. Check combustion calibration using the procedures in Section 4.4 of the <i>Benchmark PLATINUM 750–3000 Installation and Startup Guide</i>, OMM-0115 (GF-200). 4. Remove the burner and inspect for any carbon build-up or debris. Clean and reinstall. 5. Remove blockage in condensate drain.
HEAT DEMAND FAILURE	<ol style="list-style-type: none"> 1. The Heat Demand Relays on the Ignition/Stepper (IGST) board failed to activate when commanded. 2. Relay is activated when not in Demand. 	<ol style="list-style-type: none"> 1. Press CLEAR button and restart the unit. If the fault persists, replace Ignition/Stepper (IGST) Board. 2. Defective relay. Replace IGST Board.
HIGH EXHAUST TEMPERATURE	<ol style="list-style-type: none"> 1. Poor combustion calibration. 2. Carboned heat exchanger due to incorrect combustion calibration. 	<ol style="list-style-type: none"> 1. Check combustion calibration using procedures in Section 4.4 of the <i>Benchmark PLATINUM 750–3000 Installation and Startup Guide</i>, OMM-0115 (GF-200). 2. If exhaust temperature is greater than 200° F (93.3°C), check combustion calibration. Calibrate or repair as necessary.
HIGH GAS PRESSURE	<ol style="list-style-type: none"> 1. Incorrect supply gas pressure. 2. Defective SSOV Actuator. 3. Defective High Gas Pressure switch. 	<ol style="list-style-type: none"> 1. Check to ensure gas pressure at inlet of SSOV does not exceed 14” W.C. (3.49 kPa). 2. If gas supply pressure downstream of SSOV Actuator cannot be lowered to the range specified in Table 4-1 (Natural Gas) or Table 4-4 (Propane) in Section 4.4 of the <i>Benchmark PLATINUM 750–3000 Installation and Startup Guide</i>, OMM-0115 (GF-200), the SSOV Actuator may be defective. 3. Remove the leads from the High Gas Pressure switch. Measure continuity across the common (C) and normally closed (NC) terminals with the unit not firing. Replace the switch if continuity does not exist.

SECTION 5 – TROUBLESHOOTING GUIDE

TABLE 5-1: Boiler Troubleshooting Procedures

Fault Indication	Probable Causes	Corrective Action
HIGH WATER TEMP SWITCH OPEN	<ol style="list-style-type: none"> 1. Faulty Water temperature switch. 2. Incorrect PID settings. 3. Faulty shell temperature sensor. 4. Unit in MANUAL mode. 5. Unit setpoint is greater than Over Temperature switch setpoint. 6. System flow rate changes are occurring faster than units can respond. 	<ol style="list-style-type: none"> 1. Test the temperature switch to insure it trips at its actual water temperature setting. 2. Check PID settings (see Section 2-7: <i>Tuning Menu</i>, items 1 -3, for details). If the settings have been changed, record the current readings then reset them to the default values. 3. Using the resistance charts in Appendix C, measure the resistance of Shell sensor and BTU sensor at a known water temperature. 4. If unit is in MANUAL mode, switch to AUTO mode. 5. Check setpoint of unit and setpoint of Temperature switch; Ensure that the temperature switch is set higher than the unit's setpoint. 6. If the system is a variable flow system, monitor system flow changes to ensure that the rate of flow change is not faster than what the units can respond to.
HIGH WATER TEMPERATURE	<ol style="list-style-type: none"> 1. See HIGH WATER TEMPERATURE SWITCH OPEN. 2. Temp HI Limit setting is too low. 	<ol style="list-style-type: none"> 1. See HIGH WATER TEMPERATURE SWITCH OPEN. 2. Check Temp HI Limit setting.
IGN BOARD COMM FAULT	<ol style="list-style-type: none"> 1. Communication fault has occurred between the PMC board and Ignition/Stepper (IGST) board. 	<ol style="list-style-type: none"> 1. Press CLEAR button and restart unit. If fault persists, contact qualified Service Personnel.

SECTION 5 – TROUBLESHOOTING GUIDE

TABLE 5-1: Boiler Troubleshooting Procedures

Fault Indication	Probable Causes	Corrective Action
IGN SWTCH CLOSED DURING PURGE	<ol style="list-style-type: none"> 1. Air/Fuel Valve not rotating. 2. Defective or shorted switch. 3. Switch wired incorrectly. 4. Defective Power Supply Board or fuse. 5. Defective IGST Board. 	<ol style="list-style-type: none"> 1. Start the unit. The Air/Fuel Valve should rotate to the purge (open) position. If the valve does not rotate at all or does not rotate fully open, check the Air/Fuel Valve calibration. If calibration is okay, the problem may be in the Air-Fuel Valve or the C-More Controller. Refer to qualified service personnel. 2. If the Air/Fuel Valve does rotate to purge, check the ignition switch for continuity between the N.O. and COM terminals. If the switch shows continuity when not in contact with the cam replace the switch. 3. Check to ensure that the switch is wired correctly (correct wire numbers on the normally open terminals). If the switch is wired correctly, replace the switch. 4. Check DS1 & DS2 LEDs on Power Supply Board. If they are not steady ON, replace Power Supply Board. 5. Check “Heartbeat” LED DS1 and verify it is blinking ON & OFF every second. If not, replace IGST Board.
IGN SWTCH OPEN DURING IGNITION	<ol style="list-style-type: none"> 1. Air/Fuel Valve not rotating to ignition position. 2. Defective Ignition switch. 3. Defective Power Supply Board or fuse. 4. Defective IGST Board. 	<ol style="list-style-type: none"> 1. Start the unit. The Air/Fuel Valve should rotate to the purge (open) position, then back to ignition position (towards closed) during the ignition cycle. If the valve does not rotate back to the ignition position, check the Air/Fuel Valve calibration. If calibration is okay, the problem may be in the Air/Fuel Valve or the C-More Controller. Refer fault to qualified service personnel. 2. If the Air/Fuel Valve does rotate to the ignition position, check the ignition position switch for continuity between the N.O. and COM terminals when in contact with the cam. 3. Check DS1 & DS2 LEDs on Power Supply Board. If they are not steady ON, replace Power Supply Board. 4. Check “Heartbeat” LED DS1 and verify it is blinking ON & OFF every second. If not, replace IGST Board.

SECTION 5 – TROUBLESHOOTING GUIDE

TABLE 5-1: Boiler Troubleshooting Procedures

Fault Indication	Probable Causes	Corrective Action
INTERLOCK OPEN	<ol style="list-style-type: none"> 1. Interlock jumper not installed or removed. 2. Energy Management System does not have unit enabled. 3. Device proving switch hooked to interlocks is not closed. 	<ol style="list-style-type: none"> 1. Check for a jumper properly installed across the interlock terminals in the I/O box. 2. If there are two external wires on these terminals check any Energy Management system to see if they have the units disabled (a jumper may be temporarily installed to see if the interlock circuit is functioning). 3. Check that proving switch for any device hooked to the interlock circuit is closing and that the device is operational.
LINE VOLTAGE OUT OF PHASE	<ol style="list-style-type: none"> 1. Line and Neutral switched in AC Power Box. 2. Incorrect power supply transformer wiring. 	<ol style="list-style-type: none"> 1. Check hot and neutral in AC Power Box to ensure they are not reversed. 2. Check transformer wiring, in AC Power Box, against the power box transformer wiring diagram to ensure it is wired correctly.
LOW GAS PRESSURE	<ol style="list-style-type: none"> 1. Incorrect supply gas pressure. 2. Defective Low Gas Pressure switch. 	<ol style="list-style-type: none"> 1. Measure gas pressure upstream of the SSOV Actuator(s) with the unit firing. Ensure it is above the value in Table 5-1 (BMK 750-2500) or above the value calculated in step 4 in section 5.2.2 (BMK 3000) of the <i>Benchmark PLATINUM 750–3000 Installation and Startup Guide</i>, OMM-0115 (GF-200). 2. Measure gas pressure at the Low Gas Pressure switch. If it is greater than 1 inch above the Low Gas Pressure switch setting in Table 5-1 (BMK750-2500) or above the value calculated in step 4 in section 5.2.2 (BMK3000) of the <i>Benchmark PLATINUM 750–3000 Installation and Startup Guide</i>, OMM-0115 (GF-200)), measure continuity across the switch and replace if necessary.
LOW WATER LEVEL	<ol style="list-style-type: none"> 1. Insufficient water level in system. 2. Defective water level circuitry. 3. Defective water level probe. 	<ol style="list-style-type: none"> 1. Check system for sufficient water level. 2. Test water level circuitry using the C-More Controller front panel LOW WATER TEST and RESET buttons. Replace water level circuitry if it does not respond. 3. Check continuity of probe end to the shell, change probe if there is no continuity.
MODBUS COMMFAULT	Unit not seeing information from Modbus network.	Check network connections. If fault persists, contact qualified Service Personnel.

SECTION 5 – TROUBLESHOOTING GUIDE

TABLE 5-1: Boiler Troubleshooting Procedures

Fault Indication	Probable Causes	Corrective Action
<p>PRG SWTCH CLOSED DURING IGNITION</p>	<ol style="list-style-type: none"> 1. A/F Valve rotated open to purge and did not rotate to ignition position. 2. Defective or shorted switch. 3. Switch wired incorrectly. 4. Defective Power Supply Board or fuse. 5. Defective IGST Board. 	<ol style="list-style-type: none"> 1. Start the unit. The Air/Fuel Valve should rotate to the purge (open) position, then back to ignition position (towards closed) during the ignition cycle. If the valve does not rotate back to the ignition position, check the Air/Fuel Valve calibration. If calibration is okay, the problem may be in the Air/Fuel Valve or the C-More Controller. Refer fault to qualified service personnel. 2. If the Air/Fuel Valve does rotate to the ignition position, check the purge switch for continuity between the N.O. and COM terminals. If the switch shows continuity when not in contact with the cam, check to ensure that the switch is wired correctly (correct wire numbers on the normally open terminals). 3. If the switch is wired correctly, replace the switch. 4. Check DS1 & DS2 LEDs on Power Supply Board. If they are not steady ON, replace Power Supply Board. 5. Check “Heartbeat” LED DS1 and verify it is blinking ON & OFF every second. If not, replace IGST Board.
<p>PRG SWTCH OPEN DURING PURGE</p>	<ol style="list-style-type: none"> 1. Defective Purge switch. 2. No voltage present at switch. 3. Switch wired incorrectly. 4. Defective Power Supply Board or fuse 5. Defective IGST Board. 	<ol style="list-style-type: none"> 1. If the air-fuel valve does rotate, check Purge switch for continuity when closing. Replace switch if continuity does not exist. 2. Measure for 24 VAC from each side of the switch to ground. If 24VAC is not present, refer fault to qualified service personnel. 3. Check to ensure that the switch is wired correctly (correct wire numbers on the normally open terminals). 4. Check DS1 & DS2 LEDs on Power Supply Board. If they are not steady ON, replace Power Supply Board. 5. Check “Heartbeat” LED DS1 and verify it is blinking ON & OFF every second. If not, replace IGST Board.
<p>OUTDOOR TEMP SENSOR FAULT</p>	<ol style="list-style-type: none"> 1. Loose or broken wiring. 2. Defective Sensor. 3. Incorrect Sensor. 	<ol style="list-style-type: none"> 1. Inspect Outdoor Temperature sensor for loose or broken wiring. 2. Check resistance of sensor to determine if it is within specification. 3. Ensure that the correct sensor is installed.

SECTION 5 – TROUBLESHOOTING GUIDE

TABLE 5-1: Boiler Troubleshooting Procedures

Fault Indication	Probable Causes	Corrective Action
O2 % OUT OF RANGE	<ol style="list-style-type: none"> 1. Combustion Calibration incorrect. 2. Blocked inlet air duct or louver. 	<ol style="list-style-type: none"> 1. Check Combustion Analyzer and recalibrate the boiler. 2. Unblock air inlet and measure open area for combustion air to the room.
RECIRC PUMP FAILURE	<ol style="list-style-type: none"> 1. Internal recirculation pump failed. 	<ol style="list-style-type: none"> 1. Replace recirculation pump.
REMOTE SETPT SIGNAL FAULT	<ol style="list-style-type: none"> 1. Remote setpoint signal not present: Not yet installed. Wrong polarity. Signal defective at source. Broken or loose wiring. 2. Signal is not isolated (floating) if 4 to 20 mA. 3. C-More Controller signal type selection switches not set for correct signal type (voltage or current). 	<ol style="list-style-type: none"> 1. Check I/O Box to ensure signal is hooked up. Hook up if not installed. If installed, check polarity. Measure signal level. Check continuity of wiring between source and unit. 2. Check signal at source to ensure it is isolated. 3. Check DIP switch on PMC board to ensure it is set correctly for the type of signal being sent. Check control signal type set in item 6 of the <i>Configuration</i> menu (see Section 2.6: <i>Configuration Menu</i>).
RESIDUAL FLAME	<ol style="list-style-type: none"> 1. Defective Flame Detector. 2. SSOV not fully closed. 	<ol style="list-style-type: none"> 1. Replace Flame Detector. 2. Check open/close indicator window of Safety Shut-Off Valve (SSOV) and ensure that the SSOV is fully closed. If not fully closed, replace the valve and or actuator. Close the Gas Shut-Off Valve downstream of SSOV (see Section 1, Figure 1-1). Install a manometer or gauge at the leak detection port between the SSOV and Gas Shut Off Valve. If a gas pressure reading is observed replace the SSOV Valve and/or Actuator.
SSOV FAULT DURING PURGE	See SSOV SWITCH OPEN	
SSOV FAULT DURING RUN	SSOV switch closed for 15 seconds during run.	<ol style="list-style-type: none"> 1. Replace actuator.

TABLE 5-1: Boiler Troubleshooting Procedures

Fault Indication	Probable Causes	Corrective Action
SSOV RELAY FAILURE	<ol style="list-style-type: none"> 1. SSOV relay failed on IGST board. 2. Floating Neutral. 3. Hot and Neutral reversed at SSOV. 	<ol style="list-style-type: none"> 1. Press CLEAR button and restart unit. If fault persists, replace Ignition/Stepper (IGST) Board. 2. The Neutral and Earth Ground are not connected at the source and therefore there is a voltage measured between the two. Normally this measurement should be near zero or no more than a few millivolts. 3. Check SSOV power wiring.
SSOV SWITCH OPEN	<ol style="list-style-type: none"> 1. Actuator not allowing for full closure of gas valve. 2. SSOV powered when it should not be 3. Defective switch or Actuator. 4. Incorrectly wired switch. 	<ol style="list-style-type: none"> 1. Observe operation of the Safety Shut-Off Valve (SSOV) through indicator on the Valve actuator and ensure that the valve is fully and not partially closing. 2. If the SSOV never closes, it may be powered continuously. Close the gas supply and remove power from the unit. Refer fault to qualified service personnel. 3. Remove the electrical cover from the SSOV and check switch continuity. If the switch does not show continuity with the gas valve closed, either adjust or replace the switch or actuator. 4. Ensure that the SSOV Proof of Closure switch is correctly wired.
STEPPER MOTOR FAILURE	<ol style="list-style-type: none"> 1. Air/Fuel Valve out of calibration. 2. Air/Fuel Valve unplugged. 3. Loose wiring connection to the stepper motor. 4. Defective Air/Fuel Valve stepper motor. 5. Defective Power Supply Board or fuse. 6. Defective IGST Board. 	<ol style="list-style-type: none"> 1. Refer to the C-More User Manual OMM-0032 (GF-112) and perform the Stepper Feedback Calibration procedure in Section 6, section 6.2.1. 2. Check that the Air/Fuel Valve is connected to the C-More Controller. 3. Inspect for loose connections between the Air/Fuel Valve motor and the wiring harness. 4. Replace stepper motor. 5. Check DS1 & DS2 LEDs on Power Supply Board. If they are not steady ON, replace Power Supply Board. 6. Check “Heartbeat” LED DS1 and verify it is blinking ON & OFF every second. If not, replace IGST Board.

5.2 ADDITIONAL FAULTS WITHOUT SPECIFIC FAULT MESSAGES

Refer to Table 5-2 to troubleshoot faults which may occur without a specific fault message being displayed.

TABLE 5-2: Boiler Troubleshooting With No Fault Message Displayed		
Observed Incident	Probable Causes	Corrective Action
Hard Light-Off	<ol style="list-style-type: none"> 1. Clogged/damaged Gas Injector on Igniter-Injector (Figure 4-1a through Figure 4-1c). 2. Defective Staged Ignition Solenoid (Figure 4-1a through Figure 4-1c). 	<ol style="list-style-type: none"> 1. Disconnect the Staged Ignition Assembly solenoid from the Gas injector Tube of the Igniter-Injector (Figure 4-1a through Figure 4-1c) and inspect Gas Injector to ensure it is not clogged or damaged. 2. Close the Manual Shutoff Valve. Attempt to start the unit and listen for a “clicking” sound that the Staged Ignition Solenoid makes during Ignition Trial. If “clicking” sound is not heard after 2 or 3 attempts, replace the Staged Ignition Solenoid.
Fluctuating Gas Pressure	<ol style="list-style-type: none"> 1. Gas pressure going into unit is fluctuating. 2. Damping Orifice not installed. 	<ol style="list-style-type: none"> 1. Stabilize gas pressure going into unit. If necessary, troubleshoot Building Supply Regulator. 2. Check if the gas train is supposed to have a Damping Orifice, and if so, ensure that it is installed in the SSOV Actuator shown in Figure 5-1, below. For DBB Gas Trains, the Damping Orifice is installed in the downstream SSOV Actuator).
Air/Fuel Valve “hunting” at the 70% Valve Position	<ol style="list-style-type: none"> 1. IGST and Power Supply Boards in C-More Controller are outdated. 	<ol style="list-style-type: none"> 1. Check to ensure that the IGST and Power Supply Boards are Rev. E or higher.

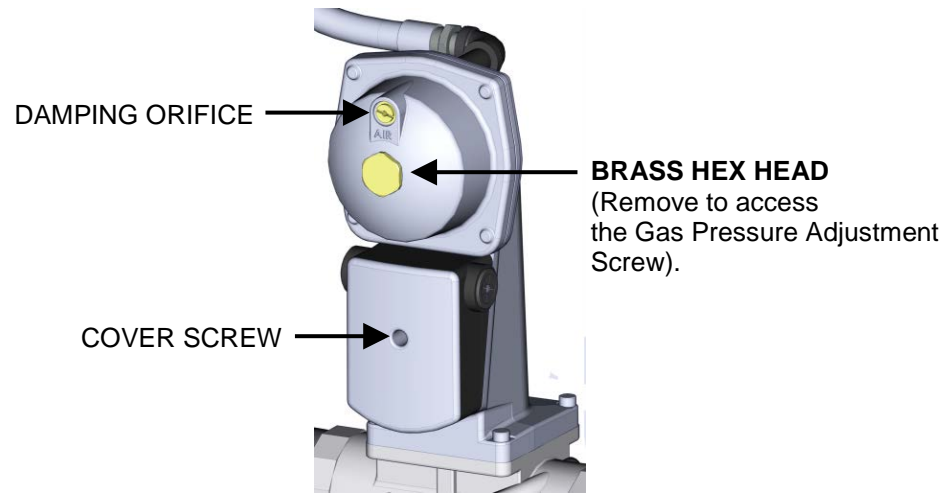

Figure 5-1: SSOV Actuator With Gas Pressure Adjustment (SKP25)

SECTION 6: AERTRIM OPERATION

6.1 AERtrim INTRODUCTION

Advanced combustion control systems need to maintain precise air/fuel ratios to maximize efficiency. Gas and oil-fired boilers often deviate from the ideal air-fuel ratio due to environmental variations such as humidity, atmospheric pressure, filter dust loading, delivered gas energy content and other factors. If the boiler is operating with fixed blower/damper positions, the air/fuel ratio will normally vary within an acceptable level, but will not be fully optimized for efficiency and reliability.

The AERtrim system is designed to measure and maintain an ideal air-fuel ratio in Benchmark boilers, thus maximizing efficiency and reliability while minimizing emissions. It does this by first measuring post combustion oxygen percentages inside the combustion chamber. This data is fed through the Electronic Control Unit (ECU) which is connected to the C-More Controller inside the boiler. If the oxygen readings are outside of preset or user defined values, the blower voltage is changed in small increments until the reading falls within the ideal range.

A simplified representation of the system is shown in Figure 6-1.

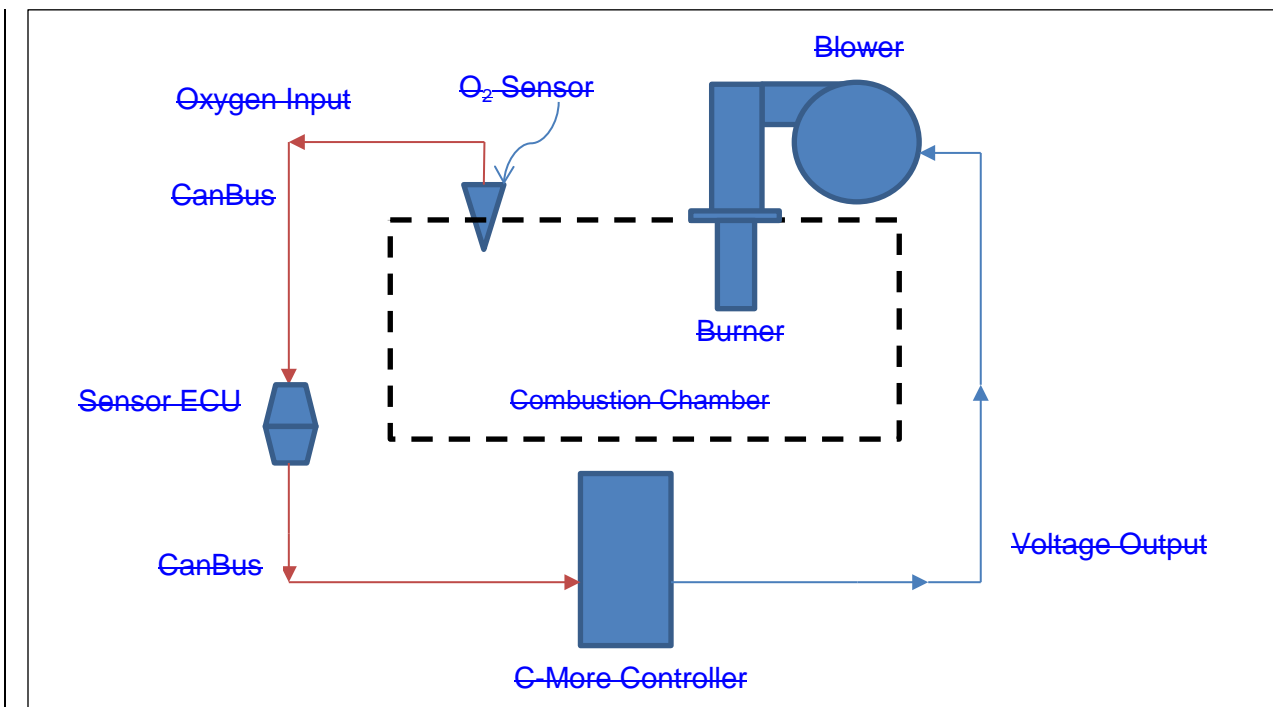

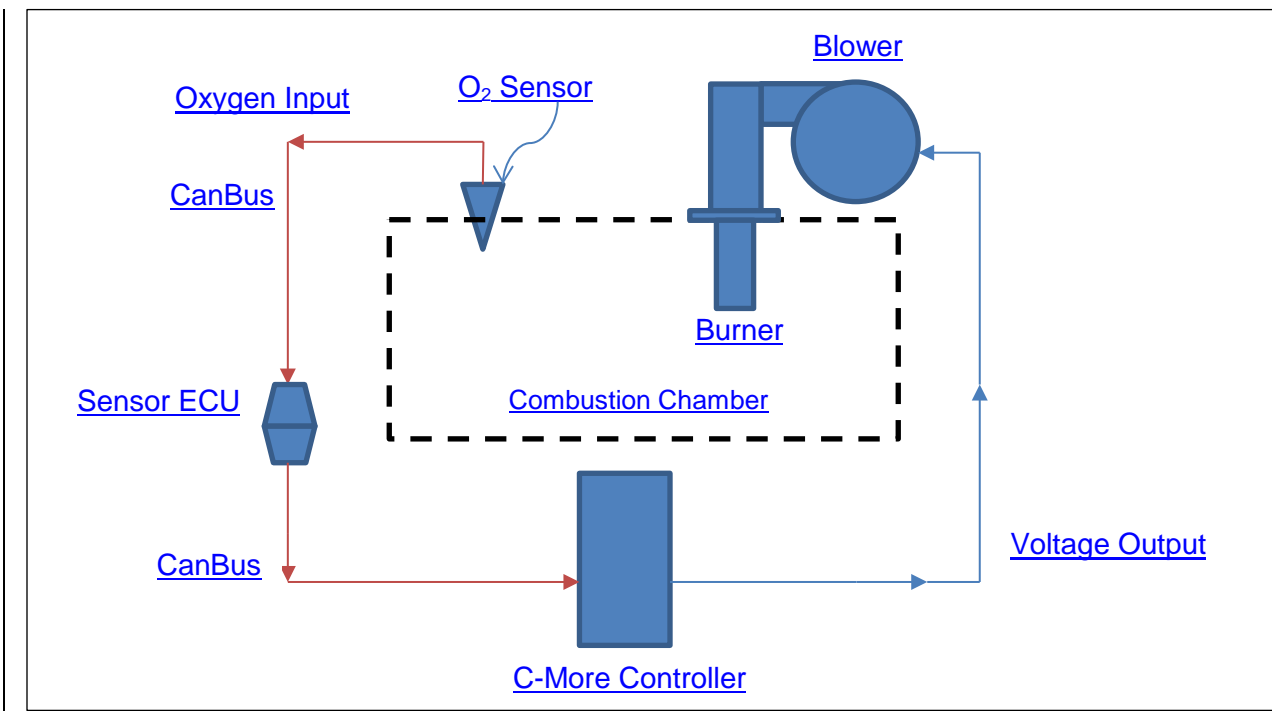

Figure 6-1: Simplified AERtrim Diagram

6.2 AERtrim ACTIVATION

AERtrim is activated at the factory prior to shipping all Benchmark Platinum boilers. However, if the C-More Controller is changed for any reason, you must activate the AERtrim function by completing the procedures below. Note that the activation code for each unit is unique, and thus cannot be transferred to any other unit; **if you have multiple units, you must take care to install the correct code on the correct unit.**

AERtrim Activation Instructions

1. Record the following information from the unit you wish to activate:
 - The unit's **Alpha – Year – Serial Number**, found on the unit's code plate. For example, for a unit built in 2017: G-17-2291.
 - **O₂ Trim ID**, found in the **O₂ Trim Key** in the C-More Controller's *Configuration Menu* (item 33 in Section 2.6).
 - **Fixed ID**, found in the **Fixed Key** in the *Configuration Menu* (item 34 in Section 2.6).
2. Contact AERCO Sales Administration with the recorded information. They will provide you with a license key.
3. Once you have obtained the license key, navigate to the **O₂ Trim Key** in the *Configuration menu* and enter the key. The *O₂ Trim Menu* and AERtrim should automatically enable. If the display does not change to the *O₂ Trim Menu*, something is wrong with the values provided to obtain the key, or with the key itself. Double check your numbers and Contact Sales Administration for another key.
4. The target O₂%, O₂ upper range, and lower range are at default values but can be changed as needed. However, you must enable the **Adjust O₂ Trgts** option in the *O₂ Trim Menu* before you can change these settings.

6.3 OPERATION DETAILS

During operation, the AERtrim system will adjust the command voltage sent to the combustion air blower within a limited range. The amount of voltage trim depends on the error between the desired O₂% (target %) and the current reading of the O₂ sensor (O₂%) and also on high and low limits of blower voltage for each valve position. The total amount of corrective voltage trim is limited by the controller to insure safe and reliable operation of the system.

The AERtrim system has a rolling active/inactive operation based on 4 hours on / 10 hours off sequence. Since this is a trim function and not an active control function, the trim activity can make adjustments in the blower voltage calibration values on the 4/10 schedule to effectively control the air/fuel mixture without continuous operation of the sensor. This method achieves the objective for long term efficiency of boiler operation while maximizing the sensor life in the boiler environment. The 14 hour cycle insures that the 4 hour on period will be active for any hour of the day every four days as shown below.

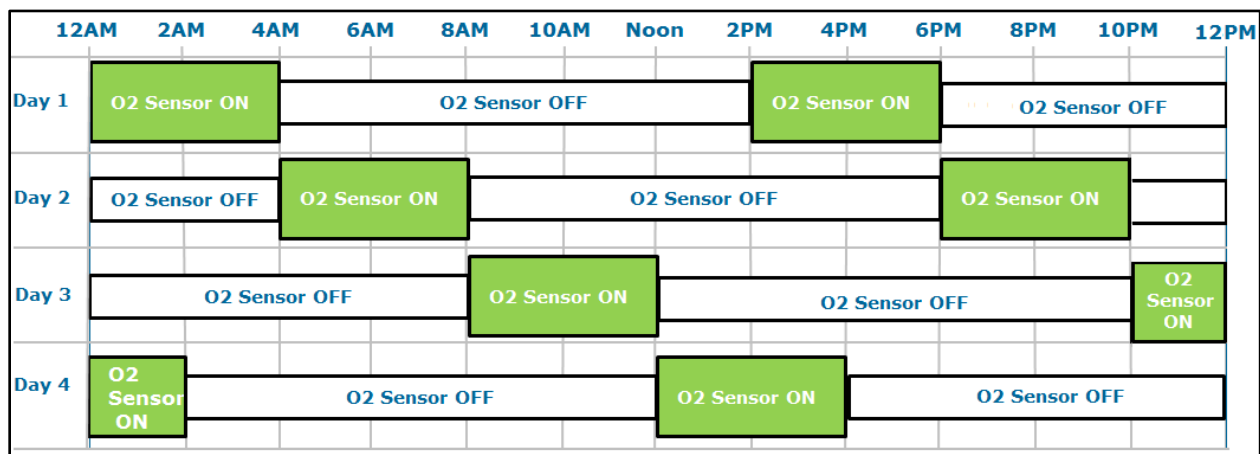

Figure 6-2: Active O₂ Sensor Cycle Coverage Chart

Figure 6-3 graphically shows the functional logic of the AERtrim system and how the blower voltage (BV), O₂ Limits, and air/fuel ratio interact during an AERtrim operation. The limits are fixed presets within the controller. The target range is adjustable within these limits to allow the user to select the optimal air/fuel ratio for a particular boiler or application.

Figure 6-3 shows how the controller would react to an O₂% reading above the upper limit. The controller will reduce the blower voltage (BV) until the O₂% reading is within the Target Range, provided the BV adjustments are within the BV limits for that unit at that fire rate. The control will then store this as the new BV calibration setting until changed manually or by another cycle of the AERtrim function.

NOTE:

When the O₂ sensor is off during the 10 hour O₂ Sensor OFF periods shown above, Modbus sends an Oxygen Level of **99** (rather than 0) to building automation system via ProtoNode.

SECTION 6 – AERTRIM OPERATION

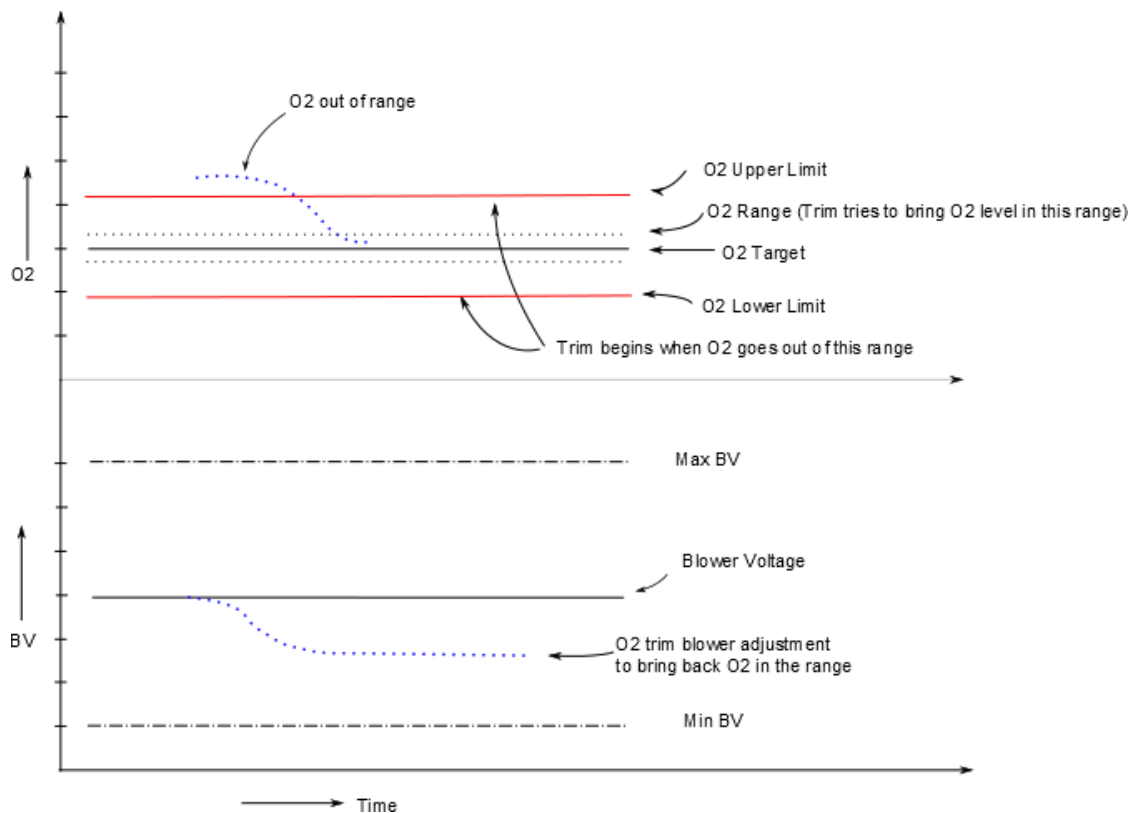

Figure 6-3: AERtrim Logic

Once the system operational stability conditions are met, the AERtrim system will execute the following steps:

1. Lock the fire rate at the current position that needs adjustment to the air/fuel ratio.
2. The Demand LED will flash once per second to indicate that the trim function has started.
3. Check the oxygen levels inside the combustion chamber:
 - If oxygen levels are within the set range, AERtrim releases control.
 - If oxygen levels are outside the set range, AERtrim will adjust Blower Voltage to bring the boiler back to the Target O₂ value.

This process repeats until the target oxygen range is achieved or the unit reaches the allowable blower voltage limit.

6.4 AERtrim AUTO CALIBRATION

AERtrim includes an automatic sensor calibration feature, which helps maintain oxygen sensor readout accuracy. This feature is disabled by default but may be enabled during AERtrim activation. Calibration frequency and time adjustments are located in the **Auto Cal Freq**, and the **Auto Cal Time** setting in the *O₂ Trim Menu* (see Section 6.5 for details).

Auto Calibration occurs only when the unit is in STANDBY Mode. For example, if the time and day for an auto calibration passes, the controller will wait for the boiler to cycle off and go into standby mode before executing the sensor calibration function. If desired, a manual calibration can be initiated by the user, by enabling the *AUTO CAL NOW* menu item.

When sensor calibration occurs, the controller starts the O₂ Cal Purge for 40 seconds (55 seconds on the BMK 6000) in order to remove residual combustion fumes. Once purged the controller reads the oxygen level of ambient air used for purging and calculates a calibration offset between -3 and +3. The offset is applied to correct the sensor reading to the expected air

O₂% level of 20.9%. If the calculated offset is more than $\pm 3\%$, “**O₂ Sensor OOR Maintenance Required**” will be displayed, and the trim function is disabled. (*OO*R is used throughout this manual for Out Of Range)

6.5 AERtrim MENU ITEMS

Most of the menu items below require the level 3 password to access.

TABLE 6-1: AERtrim Menu Items

MENU ITEMS	DESCRIPTION
*O2 Monitor	This is available in operating menu. Selecting and enabling O2 Monitoring activates the O ₂ sensor for 2 hours during the 10 hours O ₂ off period. Whenever the O ₂ sensor is enabled this option will be enabled by default.
O2 Trim	This option enables and disables AERtrim.
Settle Time	The time to settle blower speed after adjusting the blower voltage.
Trim Gain	The multiplier used to calculate an offset to a blower voltage.
Adjust O2 Target	A user can enable or disable this item to show the O ₂ targets and limit values for adjustment if a change in the O ₂ curve is desired.
onAER O2 Time	Timer to send O ₂ data periodically to AERCO's onAER or SD card
Trim State	Displays the current state of a trim function.
Fire Rate In	Displays the input fire rate.
Fire Rate Out	Displays the output fire rate.
Calc Blower Out	Displays the calculated blower voltage adjustment after each O ₂ trim iteration.
Blower Voltage	Displays the current blower voltage.
Percent Oxygen	Displays the O ₂ level.
O2 Error1 Codes	Displays O ₂ error code1. Check Error code in Section 4.7 for more details.
O2 Error2 Codes	Displays O ₂ error code2. Check Error code in Section 4.7 for more details.
Auto Cal Freq	Select calibration frequency (Never, Monthly, Weekly, Daily)
Auto Cal Time	Enter time of the day to initiate Auto calibration process if active.
Auto Cal Now	Manually enables O ₂ Auto Calibration using ambient air at 20.9% O ₂ .
O2 Offset	Displays the current O ₂ offset. Default of 1% to account for wet sample value.
O2 Timer Active	Display the active O ₂ trim timer.
**O2 Warnings	Enables or Disables all warnings from AERtrim system

*This item is in the top level operating menu

**This item is in the configuration menu

6.6 AERtrim MENU VALUES and DEFAULTS

BMK 750 AERtrim Values				
MENU ITEM		MINIMUM	MAXIMUM	DEFAULT
Settle Time		0	120 Sec	20 Sec
Trim Gain		0.1	5.0	0.250
Max Tries		0	100	15
O ₂ Target (must be between O ₂ Upper & O ₂ Lower)	18%	3%	8%	5.5%
	30%	3%	8%	5.5%
	45%	3%	8%	5.5%
	60%	3%	8%	5.5%
	80%	3%	8%	5.5%
	100%	3%	8%	5.0%
O ₂ Lower Limit (must be at least 1% lower than O ₂ Upper)	18%	2.5%	5.5%	4.5%
	30%	2.5%	5.5%	4.5%
	45%	2.5%	5.5%	4.5%
	60%	2.5%	5.5%	5.0%
	80%	2.5%	5.5%	5.0%
	100%	2.5%	5.5%	4.5%
O ₂ Upper Limit (must be at least 1% higher than O ₂ Lower)	18%	5.5%	8.5%	6.5%
	30%	5.5%	8.5%	6.5%
	45%	5.5%	8.5%	6.5%
	60%	5.5%	8.5%	6.0%
	80%	5.5%	8.5%	6.0%
	100%	5.5%	8.5%	5.5%
O ₂ Offset		-3.0	3.0	1.0

BMK 750 AERtrim Adjustment Range			
CALIBRATION POINT	BLOWER VOLTAGE		
	Minimum	Maximum	Default
18%	1.75	2.85	2.10
30%	1.95	2.60	2.55
45%	2.35	3.60	3.10
60%	3.00	3.90	3.50
80%	3.80	4.75	4.60
100%	4.75	6.00	5.60

BMK 1000 AERtrim Values

SECTION 6 – AERTRIM OPERATION

MENU ITEM		MINIMUM	MAXIMUM	DEFAULT
Settle Time		0	120 Sec	20 Sec
Trim Gain		0.1	5.0	0.250
Max Tries		0	100	15
O ₂ Target (must be between O ₂ Upper & O ₂ Lower)	18%	3%	8%	5.5%
	30%	3%	8%	5.5%
	45%	3%	8%	5.5%
	60%	3%	8%	5.5%
	80%	3%	8%	5.5%
	100%	3%	8%	5.0%
O ₂ Lower Limit (must be at least 1% lower than O ₂ Upper)	18%	2.5%	5.5%	4.5%
	30%	2.5%	5.5%	4.5%
	45%	2.5%	5.5%	5.0%
	60%	2.5%	5.5%	5.0%
	80%	2.5%	5.5%	5.0%
	100%	2.5%	5.5%	4.5%
O ₂ Upper Limit (must be at least 1% higher than O ₂ Lower)	18%	5.5%	8.5%	6.5%
	30%	5.5%	8.5%	6.5%
	45%	5.5%	8.5%	6.0%
	60%	5.5%	8.5%	6.0%
	80%	5.5%	8.5%	6.0%
	100%	5.5%	8.5%	5.5%
O ₂ Offset		-3.0	3.0	1.0

BMK 1000 AERtrim Adjustment Range			
CALIBRATION POINT	BLOWER VOLTAGE		
	Minimum	Maximum	Default
18%	1.20	2.85	2.10
30%	1.95	2.60	2.55
45%	2.35	3.60	3.10
60%	3.00	3.90	3.50
80%	3.80	4.75	4.60
100%	4.75	6.00	5.60

SECTION 6 – AERTRIM OPERATION

BMK 1500 AERtrim Values				
MENU ITEM		MINIMUM	MAXIMUM	DEFAULT
Settle Time		0	120 Sec	20 Sec
Trim Gain		0.1	5.0	0.250
Max Tries		0	100	15
O ₂ Target (must be between O ₂ Upper & O ₂ Lower)	16%	3%	8%	5.5%
	30%	3%	8%	6.5%
	40%	3%	8%	6.5%
	50%	3%	8%	6.5%
	70%	3%	8%	6.0%
	100%	3%	8%	5.0%
O ₂ Lower Limit (must be at least 1% lower than O ₂ Upper)	16%	2.5%	5.5%	5.0%
	30%	2.5%	5.5%	5.0%
	40%	2.5%	5.5%	5.0%
	50%	2.5%	5.5%	5.0%
	70%	2.5%	5.5%	5.0%
	100%	2.5%	5.5%	4.5%
O ₂ Upper Limit (must be at least 1% higher than O ₂ Lower)	16%	5.5%	8.5%	6.0%
	30%	5.5%	8.5%	7.0%
	40%	5.5%	8.5%	7.0%
	50%	5.5%	8.5%	7.0%
	70%	5.5%	8.5%	6.5%
	100%	5.5%	8.5%	5.5%
O ₂ Offset		-3.0	3.0	1.0

BMK 1500 AERtrim Adjustment Range			
CALIBRATION POINT	BLOWER VOLTAGE		
	Minimum	Maximum	Default
16%	1.40	3.30	1.80
30%	1.90	4.60	2.30
40%	2.30	5.70	2.50
50%	2.50	5.70	2.90
70%	2.70	6.30	3.80
100%	6.00	10.00	7.90

SECTION 6 – AERTRIM OPERATION

BMK 2000 AERtrim Values				
MENU ITEM		MINIMUM	MAXIMUM	DEFAULT
Settle Time		0	120 Sec	20 Sec
Trim Gain		0.1	5.0	0.250
Max Tries		0	100	15
O ₂ Target (must be between O ₂ Upper & O ₂ Lower)	18%	3%	8%	6.5%
	30%	3%	8%	6.0%
	40%	3%	8%	6.0%
	50%	3%	8%	5.5%
	70%	3%	8%	5.5%
	100%	3%	8%	5.0%
O ₂ Lower (must be at least 1% lower than O ₂ Upper)	18%	2.5%	5.5%	5.0%
	30%	2.5%	5.5%	5.5%
	40%	2.5%	5.5%	5.5%
	50%	2.5%	5.5%	5.0%
	70%	2.5%	5.5%	5.0%
	100%	2.5%	5.5%	4.5%
O ₂ Upper (must be at least 1% higher than O ₂ Lower)	18%	5.5%	8.5%	7.0%
	30%	5.5%	8.5%	6.5%
	40%	5.5%	8.5%	6.5%
	50%	5.5%	8.5%	6.0%
	70%	5.5%	8.5%	6.0%
	100%	5.5%	8.5%	5.5%
O ₂ Offset		-3.0	3.0	1.0

BMK 2000 AERtrim Adjustment Range			
CALIBRATION POINT	BLOWER VOLTAGE		
	Minimum	Maximum	Default
18%	1.90	4.00	1.40
30%	2.70	7.70	3.80
40%	3.00	7.70	4.30
50%	3.30	7.70	5.40
70%	4.00	9.60	6.40
100%	6.00	10.00	9.50

SECTION 6 – AERTRIM OPERATION

BMK 2500 AERtrim Values				
MENU ITEM		MINIMUM	MAXIMUM	DEFAULT
Settle Time		0	120 Sec	20 Sec
Trim Gain		0.1	5.0	0.250
Max Tries		0	100	15
O ₂ Target (must be between O ₂ Upper & O ₂ Lower)	16%	3%	8%	5.5%
	30%	3%	8%	6.5%
	40%	3%	8%	7.0%
	50%	3%	8%	6.0%
	70%	3%	8%	6.0%
	100%	3%	8%	5.0%
O ₂ Lower (must be at least 1% lower than O ₂ Upper)	16%	2.5%	5.5%	5.0%
	30%	2.5%	5.5%	4.5%
	40%	2.5%	5.5%	5.0%
	50%	2.5%	5.5%	5.5%
	70%	2.5%	5.5%	5.5%
	100%	2.5%	5.5%	4.5%
O ₂ Upper (must be at least 1% higher than O ₂ Lower)	16%	5.5%	8.5%	6.0%
	30%	5.5%	8.5%	7.0%
	40%	5.5%	8.5%	7.5%
	50%	5.5%	8.5%	6.5%
	70%	5.5%	8.5%	6.5%
	100%	5.5%	8.5%	5.5%
O ₂ Offset		-3.0	3.0	1.0

BMK 2500 AERtrim Adjustment Range			
CALIBRATION POINT	BLOWER VOLTAGE		
	Minimum	Maximum	Default
16%	1.90	2.90	2.20
30%	3.00	4.90	4.10
40%	3.70	5.90	4.80
50%	4.20	6.40	5.30
70%	5.20	8.40	6.80
100%	6.50	9.20	8.50

SECTION 6 – AERTRIM OPERATION

BMK 3000 AERtrim Values				
MENU ITEM		MINIMUM	MAXIMUM	DEFAULT
Settle Time		0	120 Sec	20 Sec
Trim Gain		0.1	5.0	0.250
Max Tries		0	100	15
O ₂ Target (must be between O ₂ Upper & O ₂ Lower)	14%	3%	8%	6.5%
	30%	3%	8%	7.3%
	40%	3%	8%	7.5%
	50%	3%	8%	7.0%
	70%	3%	8%	5.5%
	100%	3%	8%	5.0%
O ₂ Lower (must be at least 1% lower than O ₂ Upper)	14%	2.5%	5.5%	5.5%
	30%	2.5%	5.5%	5.5%
	40%	2.5%	5.5%	5.5%
	50%	2.5%	5.5%	5.5%
	70%	2.5%	5.5%	5.0%
	100%	2.5%	5.5%	4.5%
O ₂ Upper (must be at least 1% higher than O ₂ Lower)	14%	5.5%	8.5%	7.0%
	30%	5.5%	8.5%	7.8%
	40%	5.5%	8.5%	8.0%
	50%	5.5%	8.5%	7.5%
	70%	5.5%	8.5%	6.0%
	100%	5.5%	8.5%	5.5%
O ₂ Offset		-3.0	3.0	1.0

BMK 3000 AERtrim Adjustment Range			
CALIBRATION POINT	BLOWER VOLTAGE		
	Minimum	Maximum	Default
14%	2.60	4.90	2.80
30%	3.60	7.00	4.60
40%	4.60	8.00	5.00
50%	5.00	9.20	5.50
70%	6.10	10.00	6.90
100%	7.60	10.00	9.10

6.7 AERtrim MAINTENANCE and TROUBLESHOOTING

The AERtrim system, which maximizes blower efficiency, depends on the O₂ sensor. The AERtrim system needs only minimal maintenance. It is recommended that you **inspect the oxygen sensor for accuracy every 12 months** by comparing it to a sensor reading from a properly calibrated flue analyzer. This is strongly advised because contaminated air or gas supplies may cause impurity buildup and shift the calibration point. An offset value of ±3% can be entered in the Trim menu to correct the reading during manual calibration. If the sensor has a large amount of offset, a replacement may be required soon.

Occasional software updates to the device may be required. See TID-0156 for the software update procedure.

TABLE 6-2: AERtrim General Warnings		
WARNING	CAUSE	POSSIBLE SOLUTIONS
O2 PERCENTAGE LOW	O ₂ Levels less than 2% for more than 30 seconds {auto-reset when valve comes back in range}	Dirty filter or poor combustion calibration – recalibrate unit
		O ₂ Offset too low – Increase Offset value
		Bad Sensor-Replace
O2 SENSOR MALFUNCTION	O ₂ Levels less than -4% or more than 24% for more than 10 seconds {manual clearing of this fault is required}	Bad Sensor-Replace Communication Issue – check wires and connections
WARNING O2 LEVEL HIGH	O ₂ Levels > 9% and < 24% for more than 30 seconds {auto-reset when value comes back in range}	Gas Pressure Regulator or Air Blower Problem, or bad Combustion Calibration
		O ₂ Offset too high
		Bad Sensor-Replace
O2 SENSOR OOR MAINT REQUIRED (OutOfRange)	Sensor auto calibration offset required is more than ±3%	Reset Unit-Recalibrate Sensor
		Bad Sensor-Replace
		Bad ECU-Replace (Rare)
O2 WARNING SERVICE REQUIRED	If the O ₂ level is outside of its limits for more than 5 minutes. For example: 1) Reading < Lower Limit & Blower Voltage = BV Limit OR 2) Reading > Upper Limit & Blower Voltage = BV Limit	Gas Supply, Air Filter, or Air Blower issue
		Bad Sensor-Replace

SECTION 6 – AERTRIM OPERATION

The C-More does not display a message when O₂ levels are within the target range. However, if O₂ levels fall outside the target range, one of the messages listed in Table 6-3 will be displayed when you view the **Trim State** menu item in the **O2 Trim** menu.

TABLE 6-3: AERtrim Operation Interruption Errors		
ERROR MESSAGE	CAUSE	POSSIBLE SOLUTIONS
BV Hi Err	Trim operation exceeds allowable blower voltage limits	Check air filter, gas regulator, combustion calibration
BV Lo Err		Check sensor calibration; it may need to be replaced
Max Iter	Trim Operation reached maximum iteration. Wait and try again	Check sensor calibration for inaccuracies
		Increase gain or iteration attempts
Tmp Rng Err	Outlet temp is outside of temperature range	None-Normal Operation
FR Rng Err	Fire Rate is not within track range during trim operation	None – Steady State has not been achieved

(This page intentionally blank)

Appendix A: BOILER MENU ITEM DESCRIPTIONS

TABLE A-1: OPERATING MENU ITEM DESCRIPTIONS

See Section 2-4 OPERATING Menu for a range of choices and the default values.

TABLE A-1: OPERATING Menu Item Descriptions		
MENU OPTIONS		DESCRIPTION
1	Active Setpoint	This is the setpoint temperature to which the control is set when operating in the Constant Setpoint, Remote Setpoint or Outdoor Reset Mode. When in the Constant Setpoint Mode, this value is equal to the Internal Setpoint setting in the Configuration Menu. When in the Remote Setpoint Mode, this value is the setpoint equivalent to the remote analog signal supplied to the unit. When in the Outdoor Reset Mode, this is the derived value from the charts in Appendix E.
2	Outlet Temp	Displays the outlet water temperature.
3	Inlet Temp	Displays the inlet water temperature.
4	Air Temp	Air Temp is the air temperature at the input to the Air/Fuel Valve. This reading is one of the parameters used to control the Blower Motor speed.
5	Outdoor Temp	Outdoor temperature is displayed in °F or °C, only if outdoor temperature sensor is installed and enabled.
6	Valve Position In	Desired input valve position. This would normally be the same as the fire valve position shown on the bar graph (valve position out) when the boiler is operating.
7	Valve Position Out	Displays actual real time Valve Position.
8	FFWD Temp	Displays BST header temperature
9	Exhaust Temp	Displays the exhaust temperature in °F (default) or °C.
10	Flame Strength	Displays flame strength from 0% to 100%.
11	Min Flame Str	Not Used
12	O2 Monitor	Enables or disables the O2 Monitor.
13	Oxygen Level	Displays the real-time combustion oxygen (O ₂) level (%) measured by the O ₂ sensor.
14	Ignition Time	Displays the elapsed time between confirmation of gas valve opening (POC) until a stable flame is detected.
15	SSOV Time to OPN	Displays the elapsed time between 120VAC being applied to the Gas Valve and confirmation of gas valve opening (POC).
16	Spark Current	Displays the current going to the ignition transformer.
17	Run Cycles	Displays the total number of run cycles.
18	Run Hours	Displays total run time of unit in hours.

APPENDIX A: BOILER MENU DESCRIPTIONS

TABLE A-1: OPERATING Menu Item Descriptions		
MENU OPTIONS		DESCRIPTION
19	Fault Log	Displays information on the last 20 faults.

An additional parameter associated with the Operating menu, **Manual Valve Pos** (Min = 0, Max = 100) does not appear in this menu, but can be displayed by pushing the **Auto/Man** button on the C-More Controller's front face.

TABLE A-2: Setup Menu Item Descriptions

See Section 2-5 SETUP Menu for a range of choices and the default values.

MENU OPTIONS		DESCRIPTION
1	Password	Allows Level 1 or Level 2 password to be entered. Entering the Level 1 Password (159) allows options in the <i>Setup</i> , <i>Configuration</i> and <i>Tuning</i> menus to be modified. Entering the Level 2 Password (6817) allows options in the Calibration and Diagnostics Menus to be changed or activated, in addition to all Level 1 Menu options.
2	Language	Permits selection of the language of displayed messages. English is the only option at this time.
3	Time	Allows user to set the time, from 12:00 am to 11:59 pm.
4	Date	Allows user to set the date, from 01/01/00 to 12/31/99
5	Unit of Temp	Permits selection of temperature displays in degrees Fahrenheit (°F) or degrees Celsius (°C).
6	Comm Address	For RS-485 communications. RS232 should have its own (programmable) password.
7	Baud Rate	Allows communications Baud Rate to be set (2400 to 19.2K). Default is 9600.
8	onAER Mode	Allows selection of either Ethernet or SD Card .
9	Min Upload Timer	Mandatory for AERCO onAER Remote Data Collection (ORDC). This parameter enables ORDC and defines the minimum amount of time between heartbeat data uploads in seconds. The COMM LED will light during the upload.
10	Unit Alpha	Mandatory for AERCO onAER Remote Data Collection. This value must match the first alpha digit on the Code Plate, e.g., G-12-1234 .
11	Unit Year	Mandatory for AERCO onAER Remote Data Collection. This value must match the 2-digit year on the Code Plate, e.g., G- 12 -1234.
12	Unit Serial #	Mandatory for AERCO onAER. Remote Data Collection. This value must match the 4-digit serial # on the Code Plate, e.g., G-12- 1234 .
13	Software Version	Identifies the current software version of the C-More Controller.

TABLE A-3: Configuration Menu Item Descriptions

See Section 2-6 CONFIGURATION Menu for a range of choices and the default values.

The *Configuration* menu settings are Factory-Set in accordance with the requirements specified with each individual order. No changes will be required under normal operating conditions.

MENU OPTIONS		DESCRIPTION
1	Internal Setpoint	Allows internal setpoint to be set from Lo Temp Limit of 40°F to Hi Temp Limit of 240°F (4.4°C to 115.6°C).
2	Unit Type	Can be one of the following: BMK Blr Std, BMK Blr Std Dual, BMK Blr LN, BMK Blr LN Dual.
3	Unit Size	Sets unit size, depending on the Unit Type: 750 MBH (220 kW), 1000 MBH (293 kW), 1500 MBH (439.6 kW), 2000 MBH (586.1 kW), 2500 MBH (732.6 kW), 3000 MBH (879.2 kW)
4	Fuel Type	Allows selection of Natural Gas or Propane.
5	Boiler Mode	Only available if Unit Type = Boiler. Allows selection of: Constant Setpoint, Remote Setpoint, Direct Drive, Combination, or Outdoor Reset Mode.
6	Remote Signal	Only available if Mode = Remote Setpoint, Direct Drive or Combination. Used to set the type of external signal which will be used when operating in the Remote Setpoint, Direct Drive or Combination Mode.
7	Outdoor Sensor	Allows outdoor sensor function to be set to Enabled or Disabled.
8	Bldg Ref Temp	Only available if Boiler Mode = Outdoor Reset . Allows the building reference temperature to be set when operating a boiler in the Outdoor Reset Mode.
9	Reset Ratio	Only available if Boiler Mode = Outdoor Reset . Permits setting of Reset Ratio when operating boiler in the Outdoor Reset Mode.
10	System Start Tmp	Only if Outdoor Sensor = Enabled . This menu item allows the system start temperature to be set.
11	Setpt Lo Limit	Used to set the <i>minimum</i> allowable setpoint, from 40°F (4.4°C) up to the Setpt Hi Limit.
12	Setpt Hi Limit	Used to set the <i>maximum</i> allowable setpoint, from the Setpt Lo Limit up to 210°F (98.9°C).

APPENDIX A: BOILER MENU DESCRIPTIONS

TABLE A-3: CONFIGURATION Menu Item Descriptions		
MENU OPTIONS		DESCRIPTION
13	Temp Hi Limit	This is the maximum allowable outlet temperature, up to 210°F (98.9°C). Any temperature above this setting will turn off the unit. The temperature must then drop 5°F (2.75°C) below this setting to allow the unit to run.
14	Max Valve Position	Sets the maximum allowable valve position for the unit.
15	Pump Delay Timer	Specifies the amount of time, up to 30 minutes, to keep the pump running after the unit turns off.
16	Aux Start On Dly	Specifies the amount of time to wait, up to 120 seconds, between activating the Aux Relay (due to a demand) and checking the pre-purge string to start the boiler.
17	Failsafe Mode	Allows the Failsafe mode to be set to either Constant Setpoint or Shutdown.
18	Analog Output	Must be set to Valve Pos 0-10V for all Benchmark models. DO NOT CHANGE from its default value.
19	Lo Fire Timer	Specifies how long, from 2 to 600 seconds, to remain in the low fire position after ignition, before going to the desired output.
20	Setpt Limiting	Setpoint Limiting can be Enabled or Disabled.
21	Setpt Limit Band	The Setpoint Limit Band can be set from 0°F to 10°F (0°C to 5.5°C) .
22	Network Timeout	Specifies the timeout value in seconds before a Modbus fault is declared, up to 999 seconds.
23	Shutoff Dly Temp	This feature delays the shutdown of a boiler in order to reduce excessive cycling. This specifies the temperature value the Outlet Temperature is permitted to rise above setpoint before being shut down.
24	Demand Offset	<p>This entry will reduce excessive ON/OFF cycling in AUTO mode. When this entry is a non-zero value, the unit will not turn on again until <i>Valve Position In</i> (Operating menu item 7) reaches the Start Level value AND the Outlet Temperature goes below the <i>Active Setpoint – Demand Offset</i>. In addition, the boiler will fire at the 29% Valve Position level or below for a period of one minute.</p> <p>When this entry is set to zero, the unit will turn on again as soon as the <i>Valve Position In</i> reaches the <i>Start Level</i> value (Calibration menu item 37). There will not be a one minute delay when firing at the 29% Valve Position level.</p>

APPENDIX A: BOILER MENU DESCRIPTIONS

TABLE A-3: CONFIGURATION Menu Item Descriptions		
MENU OPTIONS		DESCRIPTION
25	Deadband High	Deadband High and Deadband Low settings create an “Outlet Temperature” Zone in which no Valve Position corrections will be attempted.
26	Deadband Low	The Deadband ZONE is defined as operating with an Outlet Temperature between Active Setpoint + Deadband High and Active Setpoint – Deadband Low. When the Outlet Temperature reaches Active Setpoint and remains there for a period of 15 seconds, the unit will go into a DEADBAND MODE at which point no Valve Position corrections will be attempted while the Outlet Temperature remains anywhere within the Deadband ZONE. When the unit is in the DEADBAND MODE, the °F or °C LED will flash on and off. When the Outlet Temperature drifts out of the Deadband ZONE, the DEADBAND MODE will be terminated and the PID LOOP will again attempt Valve Position corrections. Setting range is 0°F (0°C) to 25°F (13.75°C). Default is 5°F (2.75°C) for both Deadband High and Deadband Low).
27	IGST Version	Displays the version of the IGST Board installed.
28	IGN Time Setting	Displays the MAX Ignition time of 4 Seconds or 7 Seconds as set in the Safety String Harness.
29	Slow Shutdown	Set the Slow Shutdown feature to Enabled or Disabled.
30	Slow Sht Duration	If Slow Shutdown = Enabled , sets the time a boiler will continue to run at the Stop Level after running above the Slow Sht Threshold level, up to 9,999 seconds.
31	Slow Sht Threshold	Sets the Fire Rate above which a boiler will trigger the Slow Shutdown feature.
32	O2 Warnings	Enables or disables AERtrim warning messages.
33	O2 Trim ID	Displays 4 digit AERtrim ID number. Pre-populated on all units. Changes each time the unit is powered up.
34	Fixed ID	Displays the unit’s fixed 4 digit ID number. Pre-populated on all units. Does not change.
35	O2 Trim Key	Displays the value of the AERtrim 4 digit license key. Pre-populated on all units.
36	O2 Trim Menu	When set to Enabled, the AERtrim menu options appears.
37	BST Menu	When set to Enabled, the BST menu options appears.

TABLE A-4: Tuning Menu Item Descriptions

See Section 2-7 TUNING Menu for a range of choices and the default values.

TABLE A-4: TUNING Menu Item Descriptions			
MENU OPTIONS		DESCRIPTION	
1	Prop Band	Generates a fire rate based on the error that exists between the setpoint temperature and the actual outlet temperature. If the actual error is less than the proportional band setting (1°F to 120°F, 0.55°C to 66°C), the fire rate will be less than 100%. If the error is equal to or greater than the proportional band setting, the fire rate will be 100%.	
2	Integral Gain	This sets the fraction of the output, due to setpoint error, to add or subtract from the output each minute to move towards the setpoint. Gain is adjustable from 0.00 to 1.00 (Default is 1.0).	
3	Derivative Time	This value (0.0 to 2.0 min.) responds to the rate of change of the setpoint error. This is the time that this action advances the output.	
<p>Warmup – The feature embodied in menu items 4, 5 and 6 eliminates Temperature Overshoots during the “Warmup” period of a cold ignition cycle on all boilers by temporarily modifying the PID Gain parameter during warmup and for a period defined in the <i>Tuning</i> menu.</p>			
4	Warmup Prop Band	Range = 1 – 120°F (0.55°C to 66°C)	Default = 95 (52°C)
5	Warmup Int Gain	Range = 0.00 – 2.00	Default = .50
6	Warmup PID Timer	Range = 0 - 240 seconds	Default = 20 seconds
7	Reset Defaults?	Allows <i>Tuning</i> menu options to be reset to their Factory Default values.	

TABLE A-5: Combustion Calibration Menu Item Descriptions

See Section 2-8 COMBUSTION CAL Menu for a range of choices and the default values.

NOTE:

The Level 2 Password must be entered to view the options in the *Combustion Cal* menu. This Menu is used during the Combustion Calibration procedures described in Section 4.4 of the *Benchmark PLATINUM 750–3000 Installation and Startup Guide*, OMM-0115 (GF-200).

TABLE A-5: COMBUSTION CAL Menu Item Descriptions

MENU OPTION		DESCRIPTION	
1	CAL Voltage: BMK 750 = 18% BMK 1000 = 18% BMK 1500 = 16% BMK 2000 = 18% BMK 2500 = 16% BMK 3000 = 14%	Displays the default DC drive voltage provided to the blower at each Air/Fuel Valve position (Items 1 – 6). This drive voltage adjusts the rotational speed of the blower to maximize combustion efficiency.	
	2		CAL Voltage 30%
	3		CAL Voltage 40%
	4		CAL Voltage 50%
	5		CAL Voltage 70%
	6		CAL Voltage 100%
7	Set Valve Position	Permits selection of the Air/Fuel Valve position (% open) to be set from 0 to 100%.	
8	Blower Output	Permits the DC drive voltage to the blower to be monitored.	
9	Set Stby V out	Permits the Standby Voltage to be set from 0 to 4.00 Volts.	
10	Oxygen Level	Permits the combustion oxygen level to be displayed (0% to 25%)	

TABLE A-6: Calibration Menu Item Descriptions

See Section 2-10 CALIBRATION Menu for a range of choices and the default values.

TABLE A-6: CALIBRATION Menu Item Descriptions

MENU OPTION		DESCRIPTION
1	Stepper Fbk	Allows the Air/Fuel Valve stepper motor feedback current to be calibrated at the 0% (fully closed) and 100% (fully open) positions. Verification can also be accomplished at the 50% position.
2	Purge Timer	Allows adjustment of the pre-ignition purge time.
3	Post Purge Timer	Allows adjustment of the purge time when a unit shuts down.
4	IGN Position	Allows adjustment of the valve position (Fire Rate) during the ignition sequence.
5	Ign Pos Hold Tmr	
6	FFWD Temp Disply	Enabled or Disabled.
7	Outlet Tmp Dsply	Enabled or Disabled.
8	Inlet Tmp Dsply	Enabled or Disabled.
9	Valv Pos Out Dsp	Enabled or Disabled.
10	Exhaust Tmp Dsp	Enabled or Disabled.
11	Exhaust Safety	Enabled or Disabled.
12	Flue Material	Select flue material: PVC, Polypropylene, or stainless
13	Exhst Fault Temp	Fault threshold temperature
14	Exhst Module Temp	Decreases Valve Position to lower exhaust temperature.
15	Exhst Warn Temp	Flue temperature high warning
16	Exhst Tmp VP Adj	VP adjust value
17	Exhst Adj Rate	VP adjust rate
18	VP Change Rate	
19	VP Up Rate	Allows adjustment of the Valve Position (Fire Rate) increase rate when raising the Valve Position. VP Up Rate is defined as Seconds per Step.
20	VP Down Rate	Allows adjustment of the Valve Position (Fire Rate) decrease rate when lowering the Valve Position. VP Down Rate is defined as Seconds per Step.
21	Purge Blwr Offst	Allows adjustment of the blower speed (Blower Output Voltage) during the Purge cycle.
22	4-20mA Purge Pct	Allows adjustment of the blower speed (Blower Output Voltage) during the Purge cycle when using an Emerson VFD Drive to control the Blower Motor.
23	PWM In Adj	Allows the Pulse Width Modulation (PWM) duty cycle to be adjusted from -5.0% to +5.0% in 0.1% increments.
24	Analog In Adj	Allows adjustment of the analog input from -5.0% to +5.0%.
25	Flow In Adj	Allows adjustment of the water Flow Rate Input from -5.0% to +5.0%.
26	Supply Gas Pressure	Allows adjustment of the Supply Gas Pressure level from

APPENDIX A: BOILER MENU DESCRIPTIONS

TABLE A-6: CALIBRATION Menu Item Descriptions		
MENU OPTION		DESCRIPTION
	In Adj	-5.0% to +5.0% in 0.1 % increments.
27	Gas Plate dp In Adj	Allows adjustment of the Gas Plate dp level from -5.0% to +5.0% in 0.1% increments.
28	mA Out Adj	Allows adjustment of the milliamp output from -5.0 mA to +5.0 mA.
29	A/F Sensitivity	Allows adjustment of the Air/Fuel (A/F) Valve stepper motor sensitivity to be adjusted from 1% to 5% in 1% increments.
30	Power Reset	Allows the Power Reset Option to be set to AUTO or MANUAL.
31	Water Temp Reset	Allows the Water Temperature Reset function to be set to AUTO or MANUAL.
32	Gas Press Reset	Allows the Gas Pressure Reset function to be set to AUTO or MANUAL.
33	Min Off Time	Allows the minimum Off time to be set from 0 to 10 minutes.
34	Heatr Tuning Dsp	Allows Heater Tuning Display to be Enabled or Disabled.
35	Heatr Bkpt Dsp	Allows Heater Breakpoint Display to be Enabled or Disabled. When Enabled, Breakpoints can be viewed and/or changed.
36	Stop Level	Allows the Stop Level to be set to a valve position ranging from 0% to the presently set Start Level.
37	Start Level	Allows the Start Level to be set to a valve position ranging from the presently set Stop Level to a maximum of 40%.
SKIP FEATURE:		
Items 38 – 40 embody a feature that allows the user to define a Fire Zone the C-More will avoid. In the rare instance when a unit emits an objectionable noise at a certain Fire Rate and no other remedy solves the problem, a Fire Rate skip zone may be defined to command the C-More to Skip-Over the defined Fire Rate.		
38	– Skip Range CNTR	Defines the Center (Fire Rate) of the skip band.
39	– Skip Range Span	Defines the + and – band of the Skip Zone Size.
40	– Skip Speed	Defines the speed (Seconds/Fire Rate) at which the band will be skipped.
O2 Settings:		
Items 41 – 43 allow calibration of oxygen readings.		
41	– O2 Gain	Range = 0.5 to 1.5. (Unity Gain, No Mods)
42	– O2 Offset	Range = -3.0 to +3.0.
43	– O2 Sensor	Enables the O ₂ Sensor
44	Cal Temp Sensors	Allows calibration of the temperature sensor
Temperature Channel Offset:		
Items 45 – 50 embody the feature, which allow the user to field calibrate all six temperature channels by entering an offset corresponding to the desired temperature channel.		
45	– FFWD Temp Offset	Range: -20 to + 20 (either °F or °C)
46	– Exhst Tmp Ofset	Range: -20 to + 20 (either °F or °C)

APPENDIX A: BOILER MENU DESCRIPTIONS

TABLE A-6: CALIBRATION Menu Item Descriptions		
MENU OPTION		DESCRIPTION
47	– Outdr Air Offset	Range: -20 to + 20 (either °F or °C)
48	– Inlet Air Offset	Range: -20 to + 20 (either °F or °C)
49	– Inlet Wtr Offset	Range: -20 to + 20 (either °F or °C)
50	– Outlet Wtr Offset	Range: -20 to + 20 (either °F or °C)
51	24 hr Max Cycles	Maximum cycles in 24 hour period.
52	24 hr Max Ovrtemp	Maximum over-temp in 24 hour period.
53	0-10v Out Test	Set the blower voltage at 0-10v for testing.
54	Spark Monitor	Enables or disables the Spark Monitor function, which displays the AC current on the input of the Ignition Transformer.
56	Min Spark Amps	Allows the adjustment of the minimum spark current required at the spark transformer input.
56	Max Spark Amps	Allows the adjustment of the maximum spark current required at the spark transformer input.

(This page intentionally blank)

Appendix B: STARTUP, STATUS, & FAULT MESSAGES

Appendix B-1: STARTUP AND STATUS MESSAGES

TABLE B-1: Startup and Status Messages	
MESSAGE	DESCRIPTION
DEMAND DELAY XX sec	Displayed if Demand Delay is active.
DISABLED HH:MM pm, pm MM/DD/YY	Displayed if ON/OFF switch is set to OFF . The display also shows the time (am or pm) and date that the unit was disabled.
FLAME PROVEN	Displayed after flame has been detected for a period of 2 seconds. Initially, the flame strength is shown in %. After 5 seconds has elapsed, the time and date are shown in place of flame strength.
IGNITION TRIAL XX sec	Displayed during ignition trial of startup sequence. The duration of cycle counts up in seconds.
PURGING XX sec	Displayed during the purge cycle during startup. The duration of the purge cycle counts up in seconds.
STANDBY	Displayed when ON/OFF switch is in the ON position, but there is no demand for heat. The time and date are also displayed.
WAIT	Prompts the operator to wait.
WARMUP XX sec	Displayed for 2 minutes during the initial warm-up only.

Appendix B-2: FAULT MESSAGES

TABLE B-2: Fault Messages	
FAULT MESSAGE	FAULT DESCRIPTION
AIRFLOW FAULT DURING PURGE	The Blower Proof switch opened during purge, or air inlet is blocked.
AIRFLOW FAULT DURING IGN	The Blower Proof switch opened during ignition.
AIRFLOW FAULT DURING RUN	The Blower Proof switch opened during run.
DELAYED INTERLOCK OPEN	The Delayed Interlock is open.
DIRECT DRIVE SIGNAL FAULT	The direct drive signal is not present or is out of range.
FFWD TEMP SENSOR FAULT	The temperature measured by the Feed Forward (FFWD) Sensor is out of range.
FLAME LOSS DURING IGN	The Flame signal was not seen during ignition or lost within 5 seconds after ignition.
FLAME LOSS DURING RUN	The Flame signal was lost during run.
HEAT DEMAND FAILURE	The Heat Demand Relays on the Ignition board failed to activate when commanded.
HIGH EXHAUST TEMPERATURE	The Exhaust Temperature has exceeded 200°F (93.3°C).
GAS PRESSURE FAULT	The High Gas Pressure Limit switch is open or the Low Gas Pressure Limit switch is open.
HIGH WATER TEMPERATURE	The temperature measured by the Outlet Sensor exceeded the Temp Hi Limit setting.
HIGH WATER TEMP SWITCH OPEN	The High Water Temperature Limit switch is open.
IGN BOARD COMM FAULT	A communication fault has occurred between the PMC board and Ignition board.
IGN SWTCH CLOSED DURING PURGE	The Ignition Position Limit switch on the Air/Fuel Valve closed during purge.
IGN SWTCH OPEN DURING IGNITION	The Ignition Position Limit switch on the Air/Fuel Valve opened during ignition.
INTERLOCK OPEN	The Remote Interlock is open.
LINE VOLTAGE OUT OF PHASE	The Line (Hot) and Neutral wires are reversed.
LOW WATER LEVEL	The Low Water Cutoff board is indicating low water level.

APPENDIX B – STARTUP, STATUS, AND FAULT MESSAGES

TABLE B-2: Fault Messages	
FAULT MESSAGE	FAULT DESCRIPTION
NETWORK COMM FAULT	The RS-485 network information is not present or is corrupted.
O ₂ % OUT OF RANGE	The O ₂ % has gone below 3% or above 8%.
OUTDOOR TEMP SENSOR FAULT	The temperature measured by the Outdoor Air Sensor is out of range.
OUTLET TEMP SENSOR FAULT	The temperature measured by the Outlet Sensor is out of range: <ul style="list-style-type: none"> • OUTLET TEMPERATURE display = SHt Indicates sensor is shorted • OUTLET TEMPERATURE display = Opn indicates sensor is open-circuited
PRG SWTCH CLOSED DURING IGNITION	The Purge Position Limit switch on the Air/Fuel Valve closed during ignition.
PRG SWTCH OPEN DURING PURGE	The Purge Position Limit switch on the Air/Fuel Valve opened during purge.
REMOTE SETPT SIGNAL FAULT	The Remote Setpoint signal is not present or is out of range.
RESIDUAL FLAME	The Flame signal was seen for more than 60 seconds during standby.
SSOV SWITCH OPEN	The SSOV switch opened during standby.
SSOV FAULT DURING PURGE	The SSOV switch opened during purge.
SSOV FAULT DURING IGN	The SSOV switch closed or failed to open during ignition.
SSOV FAULT DURING RUN	The SSOV switch closed for more than 15 seconds during run.
SSOV RELAY FAILURE	A failure has been detected in one of the relays that control the SSOV.
STEPPER MOTOR FAILURE	The Stepper Motor failed to move the Air/Fuel Valve to the desired position.

(This page intentionally blank)

Appendix C: SENSOR RESISTANCE/VOLTAGE CHART

Temperature Sensor Resistance Voltage Chart (BALCO)			
TEMPERATURE		RES (OHMS)	VOLTS*
°F	°C		
-40	-40	779.0	1.93
-30	-34.4	797.5	1.96
-20	-28.9	816.3	1.99
-10	-23.3	835.4	2.02
0	-17.2	854.8	2.05
10	-12.2	874.6	2.07
20	-6.7	894.7	2.10
30	-1.1	915.1	2.12
40	4.4	935.9	2.15
50	10	956.9	2.17
60	15.5	978.3	2.20
70	21.1	1000.0	2.23
80	26.7	1022.0	2.25
90	32.2	1044.4	2.27
100	37.8	1067.0	2.30
110	43.3	1090.0	2.32
120	48.9	1113.3	2.34
130	54.4	1137.0	2.36
140	60	1160.9	2.39
150	65.6	1185.2	2.41
160	71.1	1209.5	2.43
170	76.7	1234.7	2.45
180	82.2	1260.0	2.47
190	87.8	1285.6	2.50
200	93.3	1311.4	2.52
210	98.9	1337.7	2.54
220	104.4	1364.2	2.56
230	110	1391.0	2.58
240	115.6	1418.2	
250	121.1	1445.7	

(This page intentionally blank)

Appendix D: RECOMMENDED PERIODIC TESTING

WARNING!
 Periodic testing of all boiler controls and safety devices is required to determine that they are operating as designed. Precautions shall be taken while tests are being performed to protect against bodily injury and property damage. The owner or user of an automatic boiler system should set up a formal system of periodic preventive maintenance and testing. Tests should be conducted on a regular basis and the results recorded in a log-book.

Recommended Periodic Testing			
ITEM	FREQUENCY	ACTION BY	REMARKS
NOTE: Refer to indicated sections of this manual and the <i>Benchmark Platinum 750–3000 Installation and Startup Guide</i> for detailed procedures.			
Gauges, monitors and indicators	Daily	Operator	Visual inspection and record readings in operator log
Instrument and equipment settings	Daily	Operator	Visual check against factory recommended specifications
	Weekly	Operator	Verify factory settings
Firing Rate Control	Semi-Annually	Service Technician	Verify factory settings
	Annually	Service Technician	Check with combustion calibration test equipment (see Section 4 of the <i>Benchmark PLATINUM 750–3000 Installation and Startup Guide</i> , OMM-0115 (GF-200)), and the O ₂ sensor in Section 5.4 of this guide.
Flue, vent, stack or intake air duct	Monthly	Operator	Visually inspection condition and check for obstructions
Spark Igniter-Injector	Weekly	Operator	See Section 5.2.
Air/Fuel Valve position	Weekly	Operator	Check position indicator dial. See Section 3.2 in the <i>Benchmark PLATINUM 750–3000 Installation and Startup Guide</i> , OMM-0115 (GF-200)).
SSOV Leakage test	Annually	Service Technician	Check for leakage in accordance with the SSOV manufacturer's (Siemens) recommendations.
Flame failure	Weekly	Operator	Close manual gas shutoff valve and check safety shutdown. See Section 5.7 in the <i>Benchmark PLATINUM 750–3000 Installation and Startup Guide</i> , OMM-0115 (GF-200).
Flame signal strength	Weekly	Operator	Check flame strength using the C-More Controller's <i>Operating</i> menu (see section 2.4).
Low water level cut off and alarm	Weekly	Operator	See section 5.4 in the <i>Benchmark PLATINUM 750–3000 Installation and Startup Guide</i> , OMM-0115 (GF-200).
Slow drain test	Semi-Annually	Operator	Perform a slow drain test in accordance with ASME Boiler and Pressure Vessel Code, Section IV.

APPENDIX D – RECOMMENDED PERIODIC TESTING

Recommended Periodic Testing			
ITEM	FREQUENCY	ACTION BY	REMARKS
High water temp. safety control test	Annually	Service Technician	See section 5.5 in the <i>Benchmark PLATINUM 750–3000 Installation and Startup Guide</i> , OMM-0115 (GF-200).
Operating controls	Annually	Operator	See section 2.2.
Low air flow	Monthly	Operator	See section 5.8 in the <i>Benchmark PLATINUM 750–3000 Installation and Startup Guide</i> , OMM-0115 (GF-200).
High and low gas pressure interlocks	Monthly	Operator	See sections 5.2 and 5.3 in the <i>Benchmark PLATINUM 750–3000 Installation and Startup Guide</i> , OMM-0115 (GF-200)
Air/Fuel Valve purge position switch	Annually	Service Technician	See section 5.10 in the <i>Benchmark PLATINUM 750–3000 Installation and Startup Guide</i> , OMM-0115 (GF-200)
Air/Fuel Valve ignition position switch	Annually	Service Technician	See section 5.11 in the <i>Benchmark PLATINUM 750–3000 Installation and Startup Guide</i> , OMM-0115 (GF-200)
Safety valves	As required	Operator	Check per A.S.M.E. Boiler and Pressure Vessel Code, Section IV.
Inspect burner components	Semi-Annually	Service Technician	See section 4.6.
Condensate Trap	Semi-Annually	Operator	See section 4.7.
Oxygen (O ₂) Level	Monthly	Operator	Verify oxygen level is between 3% and 8% during boiler operation.

Appendix E: INDOOR/OUTDOOR RESET RATIO CHARTS

Header Temperature for a Building Reference Temperature = 50°F (10.0°C)											
AIR TEMP		RESET RATIO									
°F	°C	0.6	0.8	1.0	1.2	1.4	1.6	1.8	2.0	2.2	2.4
50	10.0	50	50	50	50	50	50	50	50	50	50
45	7.2	53	54	55	56	57	58	59	60	60	62
40	4.4	56	58	60	62	64	66	68	70	72	74
35	1.7	59	62	65	68	71	74	77	80	83	86
30	-1.1	62	66	70	74	78	82	86	90	94	98
25	-3.9	65	70	75	80	85	90	95	100	105	110
20	-6.7	68	74	80	86	92	98	104	110	116	122
15	-9.4	71	78	85	92	99	106	113	120	127	134
10	-12.2	74	82	90	98	106	114	122	130	138	146
5	-15.0	77	86	95	104	113	122	131	140	149	158
0	-17.8	80	90	100	110	120	130	140	150	160	170
-5	-20.6	83	94	105	116	127	138	149	160	171	182
-10	-23.3	86	98	110	122	134	146	158	170	182	194
-15	-26.1	89	102	115	128	141	154	167	180	193	206
-20	-28.9	92	106	120	134	148	162	176	190	204	218

Header Temperature for a Building Reference Temperature = 60°F (15.6°C)											
AIR TEMP		RESET RATIO									
°F	°C	0.6	0.8	1.0	1.2	1.4	1.6	1.8	2.0	2.2	2.4
60	15.6	60	60	60	60	60	60	60	60	60	60
55	12.8	63	64	65	66	67	68	69	70	71	72
50	10.0	66	68	70	72	74	76	78	80	82	84
45	7.2	69	72	75	78	81	84	87	90	93	96
40	4.4	72	76	80	84	88	92	96	100	104	108
35	1.7	75	80	85	90	95	100	105	110	115	120
30	-1.1	78	84	90	96	102	108	114	120	126	132
25	-3.9	81	88	95	102	109	116	123	130	137	144
20	-6.7	84	92	100	108	116	124	132	140	148	156
15	-9.4	87	96	105	114	123	132	141	150	159	168
10	-12.2	90	100	110	120	130	140	150	160	170	180
5	-15.0	93	104	115	126	137	148	159	170	181	192
0	-17.8	96	108	120	132	144	156	168	180	192	204
-5	-20.6	99	112	125	138	151	164	177	190	203	216
-10	-23.3	102	116	130	144	158	172	186	200	214	
-15	-26.1	105	120	135	150	165	180	195	210		
-20	-28.9	108	124	140	156	172	188	204			

APPENDIX E: INDOOR/OUTDOOR RESET RATIO CHARTS

Header Temperature for a Building Reference Temperature = 65°F (18.3°C)											
AIR TEMP		RESET RATIO									
°F	°C	0.6	0.8	1.0	1.2	1.4	1.6	1.8	2.0	2.2	2.4
65	18.3	65	65	65	65	65	65	65	65	65	65
60	15.6	68	69	70	71	72	73	74	75	76	77
55	12.8	71	73	75	77	79	81	83	85	87	89
50	10.0	74	77	80	83	86	89	92	95	98	101
45	7.2	77	81	85	89	93	97	101	105	109	113
40	4.4	80	85	90	95	100	105	110	115	120	125
35	1.7	83	89	95	101	107	113	119	125	131	137
30	-1.1	86	93	100	107	114	121	128	135	142	149
25	-3.9	89	97	105	113	121	129	137	145	153	161
20	-6.7	92	101	110	119	128	137	146	155	164	173
15	-9.4	95	105	115	125	135	145	155	165	175	185
10	-12.2	98	109	120	131	142	153	164	175	186	197
5	-15.0	101	113	125	137	149	161	173	185	197	209
0	-17.8	104	117	130	143	156	169	182	195	208	
-5	-20.6	107	121	135	149	163	177	191	205	219	
-10	-23.3	110	125	140	155	170	185	200	215		
-15	-26.1	113	129	145	161	177	193	209			
-20	-28.9	116	133	150	167	201	218				

Header Temperature for a Building Reference Temperature = 70°F (21.1°C)											
AIR TEMP		RESET RATIO									
°F	°C	0.6	0.8	1.0	1.2	1.4	1.6	1.8	2.0	2.2	2.4
70	21.1	70	70	70	70	70	70	70	70	70	70
65	18.3	73	74	75	76	77	78	79	80	81	82
60	15.6	76	78	80	82	84	86	88	90	92	94
55	12.8	79	82	85	88	91	94	97	100	103	106
50	10.0	82	86	90	94	98	102	106	110	114	118
45	7.2	85	90	95	100	105	110	115	120	125	130
40	4.4	88	94	100	106	112	118	124	130	136	142
35	1.7	91	98	105	112	119	126	133	140	147	154
30	-1.1	94	102	110	118	126	134	142	150	158	166
25	-3.9	97	106	115	124	133	142	151	160	169	178
20	-6.7	100	110	120	130	140	150	160	170	180	190
15	-9.4	103	114	125	136	147	158	169	180	191	202
10	-12.2	106	118	130	142	154	166	178	190	202	214
5	-15.0	109	122	135	148	161	174	187	200	213	
0	-17.8	112	126	140	154	168	182	196	210		
-5	-20.6	115	130	145	160	175	190	205			
-10	-23.3	118	134	150	166	182	198	214			
-15	-26.1	121	138	155	172	189	206				
-20	-28.9	124	142	160	178	196	214				

Header Temperature for a Building Reference Temperature = 75°F (23.9°C)											
AIR TEMP		RESET RATIO									
°F	°C	0.6	0.8	1.0	1.2	1.4	1.6	1.8	2.0	2.2	2.4
75	23.9	75	75	75	75	75	75	75	75	75	75
70	21.1	78	79	80	81	82	83	84	85	86	87
65	18.3	81	83	85	87	89	91	93	95	97	99
60	15.6	84	87	90	93	96	99	102	105	108	111
55	12.8	87	91	95	99	103	107	111	115	119	123
50	10.0	90	95	100	105	110	115	120	125	130	135
45	7.2	93	99	105	111	117	123	129	135	141	147
40	4.4	96	103	110	117	124	131	138	145	152	159
35	1.7	99	107	115	123	131	139	147	155	163	171
30	-1.1	102	111	120	129	138	147	156	165	174	183
25	-3.9	105	115	125	135	145	155	165	175	185	195
20	-6.7	108	119	130	141	152	163	174	185	196	207
15	-9.4	111	123	135	147	159	171	183	195	207	219
10	-12.2	114	127	140	153	166	179	192	205	218	
5	-15.0	117	131	145	159	173	187	201	215		
0	-17.8	120	135	150	165	180	195	210			
-5	-20.6	123	139	155	171	187	203	219			
-10	-23.3	126	143	160	177	194	211				
-15	-26.1	129	147	165	183	201	219				

Header Temperature for a Building Reference Temperature = 80°F (26.7°C)											
AIR TEMP		RESET RATIO									
°F	°C	0.6	0.8	1.0	1.2	1.4	1.6	1.8	2.0	2.2	2.4
80	26.7	80	80	80	80	80	80	80	80	80	80
75	23.9	83	84	85	86	87	88	89	90	91	92
70	21.1	86	88	90	92	94	96	98	100	102	104
65	18.3	89	92	95	98	101	104	107	110	113	116
60	15.6	92	96	100	104	108	112	116	120	124	128
55	12.8	95	100	105	110	115	120	125	130	135	140
50	10.0	98	104	110	116	122	128	134	140	146	152
45	7.2	101	108	115	122	129	136	143	150	157	164
40	4.4	104	112	120	128	136	144	152	160	168	176
35	1.7	107	116	125	134	143	152	161	170	179	188
30	-1.1	110	120	130	140	150	160	170	180	190	200
25	-3.9	113	124	135	146	157	168	174	190	201	212
20	-6.7	116	128	140	152	164	176	188	200	212	
15	-9.4	119	132	145	158	171	184	197	210		
10	-12.2	122	136	150	164	178	192	206			
5	-15.0	125	140	155	170	185	200	215			
0	-17.8	128	144	160	176	192	208				
-5	-20.6	131	148	165	182	199	216				
-10	-23.3	134	152	170	188	206					

Header Temperature for a Building Reference Temperature = 90°F (32.2°C)											
AIR TEMP		RESET RATIO									
°F	°C	0.6	0.8	1.0	1.2	1.4	1.6	1.8	2.0	2.2	2.4
90	32.2	90	90	90	90	90	90	90	90	90	90
85	29.4	93	94	95	96	97	98	99	100	101	102
80	26.7	96	98	100	102	104	106	108	110	112	114
75	23.9	99	102	105	108	111	114	117	120	123	126
70	21.1	102	106	110	114	118	122	126	130	134	138
65	18.3	105	110	115	120	125	130	135	140	145	150
60	15.6	108	114	120	126	132	138	144	150	156	162
55	12.8	111	118	125	132	139	146	153	160	167	174
50	10.0	114	122	130	138	146	154	162	170	178	186
45	7.2	117	126	135	144	153	162	171	180	189	198
40	4.4	120	130	140	150	160	170	180	190	200	210
35	1.7	123	134	145	156	167	178	189	200		
30	-1.1	126	138	150	162	174	186	198	210		
25	-3.9	129	142	155	168	181	194	207			
20	-6.7	132	146	160	174	188	202	216			
15	-9.4	135	150	165	180	195	210				
10	-12.2	138	154	170	186	202	218				
5	-15.0	141	158	175	192	209					
0	-17.8	144	162	180	198	216					

Appendix F: Benchmark PLATINUM 750/1000 Part Lists

Benchmark 750 & 1000 Part List

Item #	Qty	Part #	Description
EXHAUST MANIFOLD			
1	1	43086	MANIFOLD: EXHAUST
2	1	84045	SEAL: EXHAUST MANIFOLD
3	1	9-22	PIPE PLUG: 1/4" NPT: STEEL
GAS TRAIN ASSEMBLY			
4	1	22140-1	STD FM GAS TRAIN ASSY
		22140-2	DBB GAS TRAIN ASSY
		22140-3	PROPANE GAS TRAIN ASSY
5	1	81155	GASKET: 1 1/4" PIPE FLANGE
BURNER, AIR/FUEL VALVE, HEAT EXCHANGER			
8	1	24276-TAB	BURNER A/F VALVE ASSEMBLY
10	1	46026	BURNER
12	1	24367-1	BMK 1000 A/F Valve Replacement Kit
		24367-2	BMK 750 A/F Valve Replacement Kit
13	1	24277	STAGED IGNITION ASSY
14	1	81143	GASKET: BURNER
17	1	28317	BMK 750 HEAT EXCHANGER (Dual Inlet)
		28249	BMK 1000 HEAT EXCHANGER (Dual Inlet)
HOSES & INSULATION			
18	1	97087-20	TUBE: FLEXIBLE GAS 20" (50.8 cm)
19	1	80080	INSULATION: SHELL
BLOWER			
20	1	58061	BLOWER BMK 750/100 Replacement Kit
24	1	24356-1	FLAME DETECTOR Replacement Kit
25	1	61026	LEAN OXYGEN SENSOR
26	1	58023	IGNITER-INJECTOR Replacement Kit
27	1	59139	AIR FILTER: 6" X 4.5 (11.4 cm) LG
CONTROLS			
28	1	123966	SWITCH: OVER TEMP-AUTO RESET
29	1	123552	SWITCH: OVER TEMP-MANUAL RESET
30	1	60011-4	BLOWER PROOF SWITCH ASSY:
31	1	61002-5	BLOCKED INLET SWITCH -4.5 W.C.
32	1	65085	IGNITION TRANSFORMER
33	1	61034	SPARK MONITOR (AC Transducer)
34	1	60026	CIRCUIT BREAKER 2 POLE 20A
35	1	64081	ECU
36	1	65011	TRANSFORMER 115V/24V 100VA
37	1	65109	12V POWER SUPPLY
39	2	65120	TERMINAL BLOCK: DIN MOUNTED: BLK
40	2	65121	TERMINAL BLOCK: DIN MOUNTED: WHT
41	3	65122	TERMINAL GROUND BLOCK: DIN MOUNTED
42	2	65118	FUSE TERMINAL: DIN MOUNTED
43	1	64088	LIMIT CONTROL TEMPERATURE
45	1	24327	ASSEMBLY: POWER SUPPLY COVER
46	1	69102-2	BENCHMARK PUMP RELAY
47	2	124512	FUSE: 4 AMP
48	2	123449	SENSOR: TEMPERATURE
49	1	58132	THERMOWELL Replacement Kit
51	1	69186-4	C-MORE CONTROLLER
52	1	69172	I/O (PCB) ASSEMBLY
53	1	69227	ONAER COMMUNICATION BOARD
60	1	65156	FLAME ROD SIGNAL AMPLIFIER
61	1	61030	OUTLET TEMP SENSOR
62	1	123449	AIR INLET TEMPERATURE SENSOR
69	1	65162	24V POWER SUPPLY (SEQUENCING VALVE)
SHEET METAL/PANEL ASSEMBLY			
70	1	37155	PANEL: LEFT (Black)
71	1	37156	PANEL: RIGHT (Black)
72	1	37154	TOP COVER ASSY (Black)
73	1	25087	FRONT FRAME ASSY. (Black)
74	1	25086	FRONT PANEL (Platinum)
77	6	59133	LATCH: COMPRESSION
78	1	50010	LATCH: DRAW
79	1	50011	KEEPER: DRAW LATCH
82	1	39217	AIR INLET ADAPTER: 6" PVC (Black)
OTHER ACCESSORIES / PARTS			
89	1	63126	LOW WATER CUTOFF CAPACITOR FRU Kit
90	1	123863	VALVE: BALL 1/8" NPT
91	1	92094	BOILER DRAIN VALVE: 3/4 MNPT x GHT
94	1	59178	VENT: AIR 1/8 NPT

❶ Not shown on drawing

AERCO International, Inc. Blauvelt, NY 10913	Benchmark 750 – 1000 Part List	09/28/2017
	BMK 750:28321-TAB rev F BMK 1000 28253-TAB rev F	Sheet 1 of 6

Benchmark 750/1000 Spare Parts Kit P/N 58037-TAB

Part Number	Description	58037-1	58037-2	58037-3	58037-4	58037-5	58037-6	58037-7	58037-8
		30 PSI Apollo	50 PSI Conbraco	75 PSI Apollo	100 PSI Watts	150 PSI Watts	60 PSI Watts	125 PSI Watts	160 PSI Kunkle
24286	6" Exhaust Kit	1	1	1	1	1	1	1	1
24441	Condensate Trap Assy.	1	1	1	1	1	1	1	1
92006-5	1" Ball Valve	1	1	1	1	1	1	1	1
123675-2	Tridicator	1	1						
123675-3	Tridicator			1	1		1	1	
123675-4	Tridicator					1			1
92014	Pressure Relief Valve		1						
92015-13	Pressure Relief Valve						1		
92015-15	Pressure Relief Valve				1				
92015-16	Pressure Relief Valve							1	
92015-20	Pressure Relief Valve			1					
92015-484	Pressure Relief Valve								1
92015-361	Pressure Relief Valve	1							
123659	Pressure Relief Valve					1			
9-234	¾" Close Nipple	1		1	1	1	1	1	1

Wiring Harnesses (not shown in figures below)

Part #	Description
63182	HARNESS: SHELL
63083	HARNESS: O2 SENSOR
63085	HARNESS: CONTROL
63090	HARNESS: TEMPERATURE LIMIT CONTROL
63097	HARNESS: I/O SENSOR/COMM
63147	HARNESS: WIRING: GAS TRAIN
63150	HARNESS: FLAME ROD
65104	CABLE: H.V. IGNITION
124327	HARNESS: INTERLOCK

Additional Benchmark 750/1000 Kits Available

Part #	Description
27086-1	ACTUATOR: SSOV w/o P.O.C. SWITCH Replacement Kit
64048	SSOV WITH PRESSURE REGULATOR Replacement Kit

Other Accessories / Parts (Optional)

Part #	Description
92084-6	MOTORIZED SEQUENCING VALVE

AERCO International, Inc. Blauvelt, NY 10913	Benchmark 750 – 1000 Part List	09/28/2017
	BMK 750:28321-TAB rev F BMK 1000 28253-TAB rev F	Sheet 2 of 6

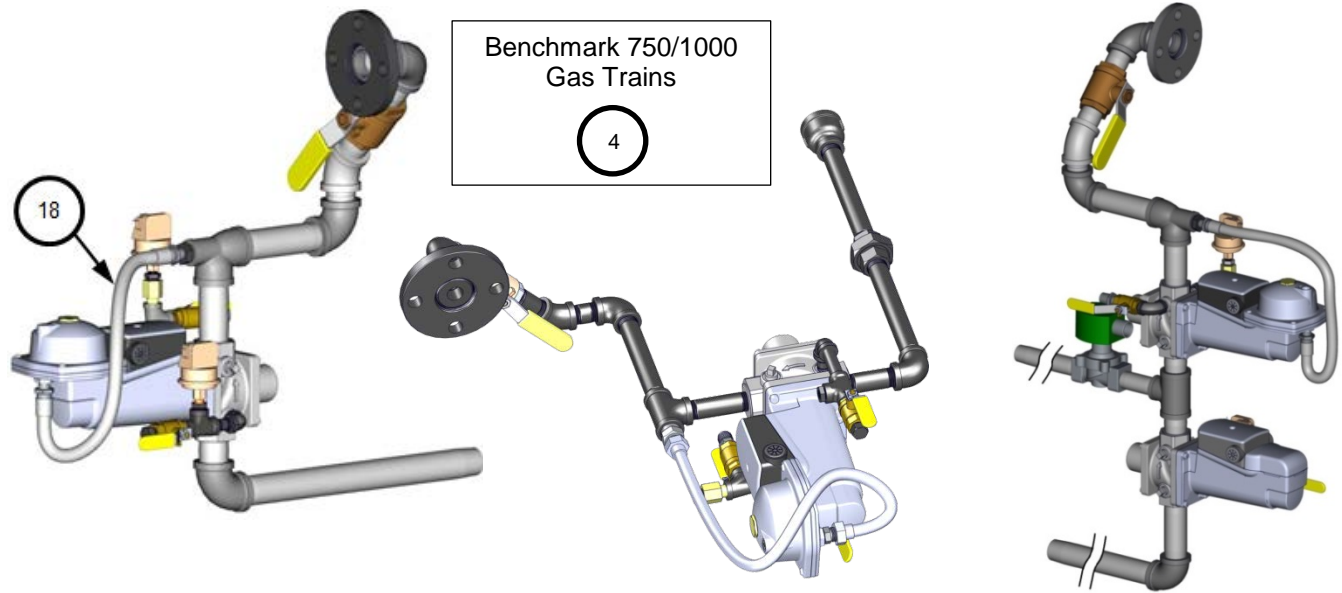

FM Gas Train 22140-1

Propane Gas Train 22140-3

DBB Gas Train 22140-2

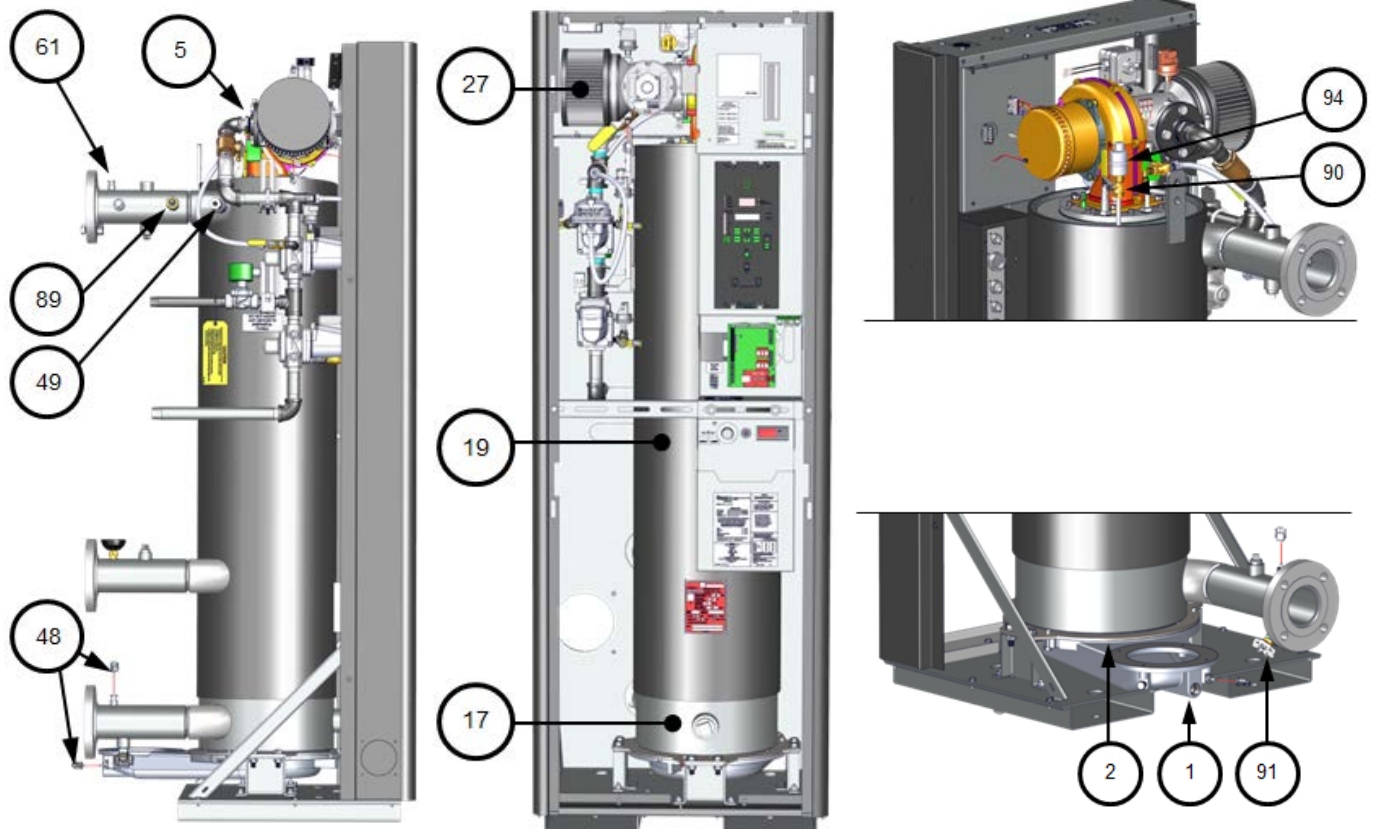

LEFT-REAR VIEW

FRONT VIEW

RIGHT-REAR VIEW

AERCO International, Inc. Blauvelt, NY 10913	Benchmark 750 – 1000 Part List	09/28/2017
	BMK 750:28321-TAB rev F BMK 1000 28253-TAB rev F	Sheet 3 of 6

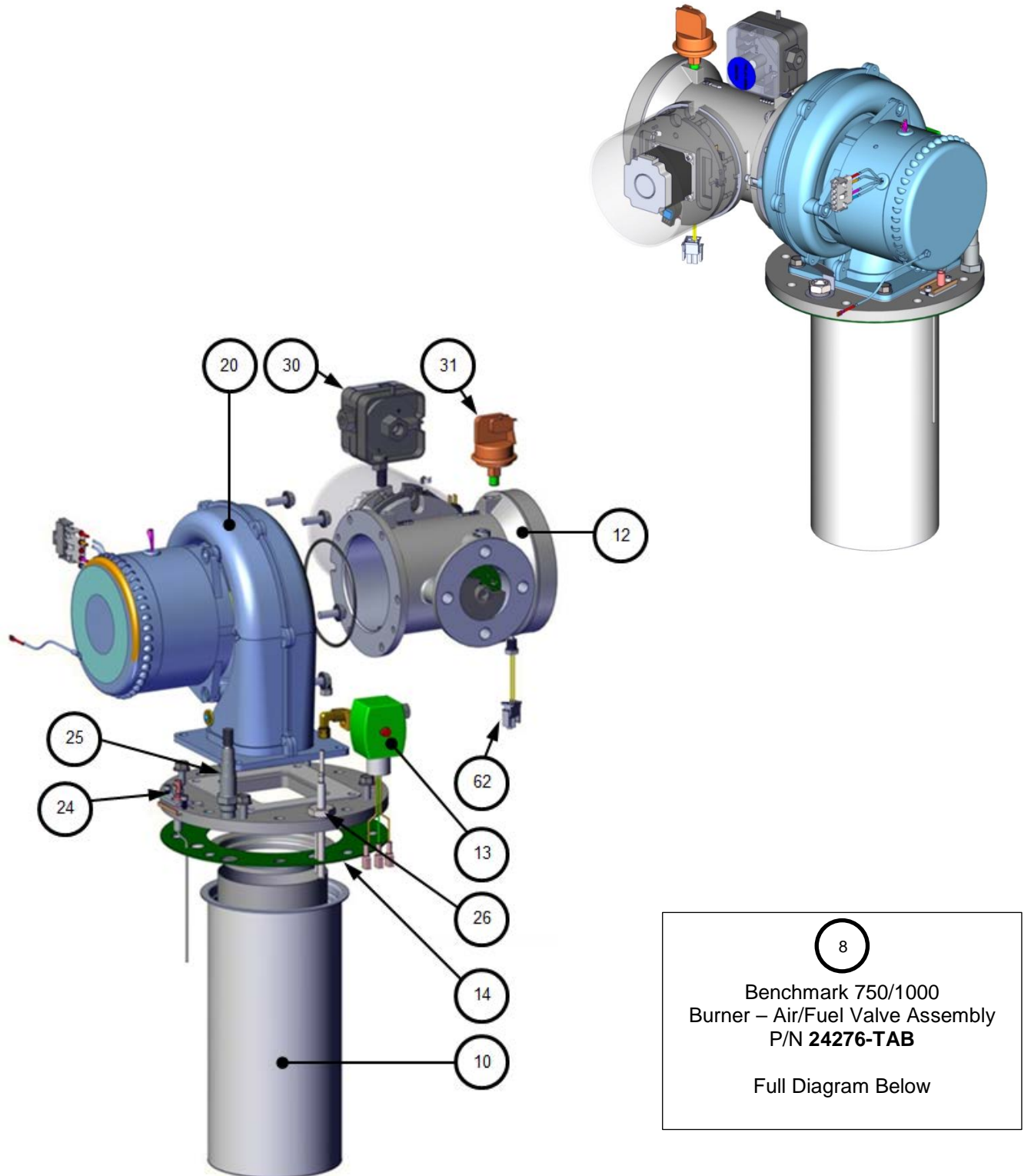

8
 Benchmark 750/1000
 Burner – Air/Fuel Valve Assembly
 P/N 24276-TAB
 Full Diagram Below

AERCO International, Inc. Blauvelt, NY 10913	Benchmark 750 – 1000 Part List	09/28/2017
	BMK 750:28321-TAB rev F BMK 1000 28253-TAB rev F	Sheet 4 of 6

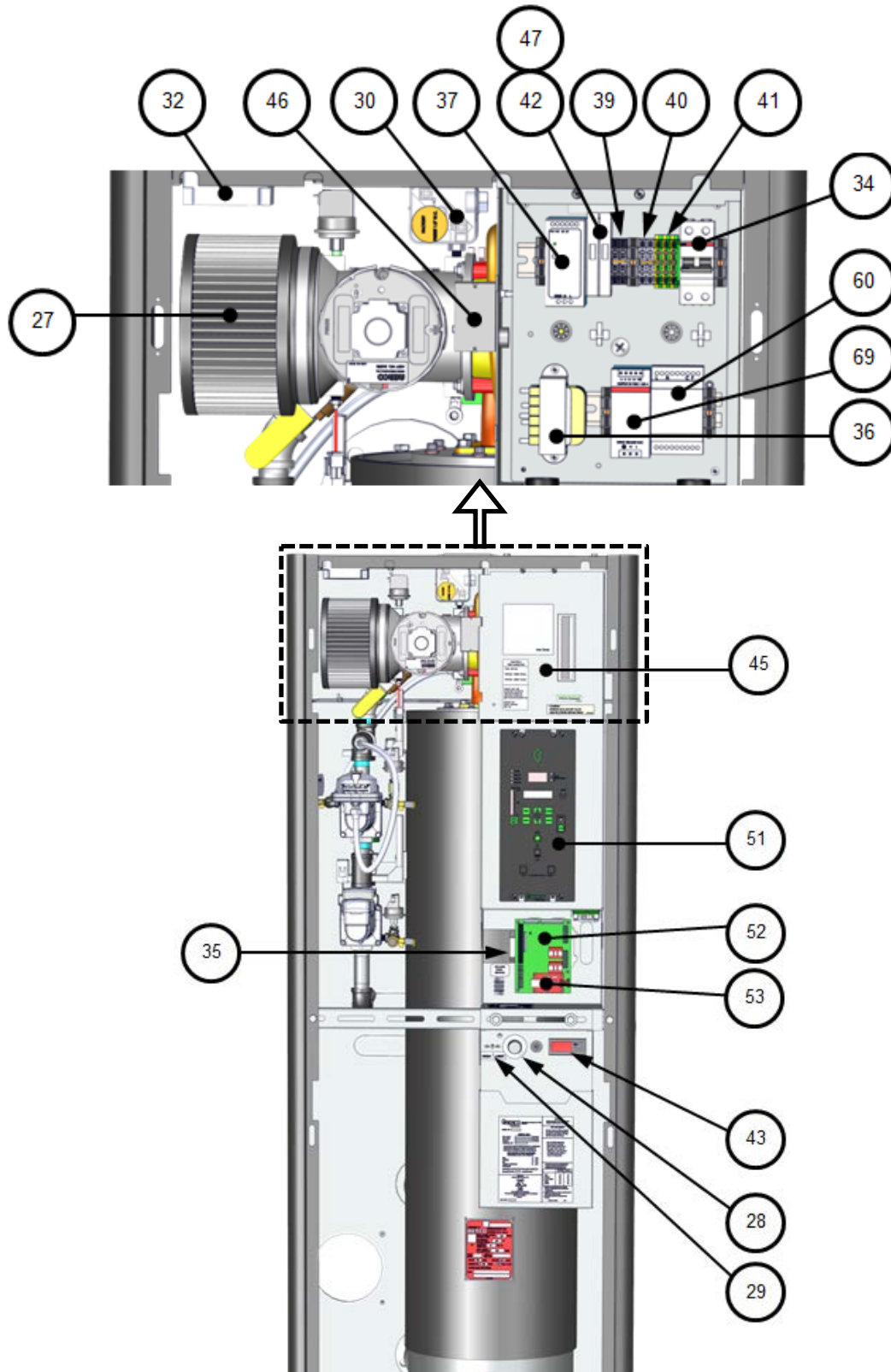

AERCO International, Inc. Blauvelt, NY 10913	Benchmark 750 – 1000 Part List	09/28/2017
	BMK 750:28321-TAB rev F BMK 1000 28253-TAB rev F	Sheet 5 of 6

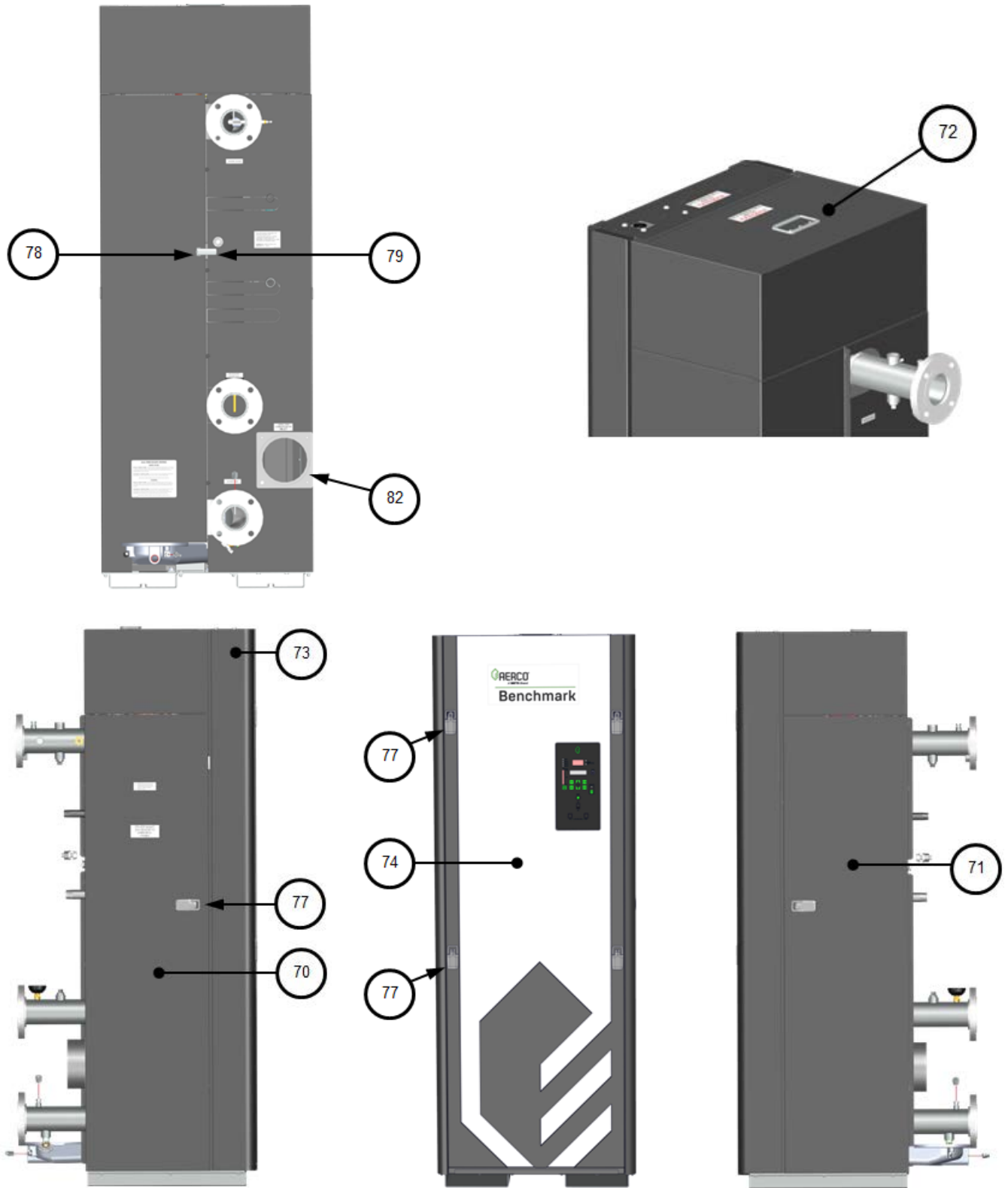

AERCO International, Inc. Blauvelt, NY 10913	Benchmark 750 – 1000 Part List	09/28/2017
	BMK 750:28321-TAB rev F BMK 1000 28253-TAB rev F	Sheet 6 of 6

Benchmark 750-1000 FM Gas Train – 22140-1

Item	Qty	Part #	Description	Item	Qty	Part #	Description
1	1	95026	1.25"NPT 125#: THREADED FLANGE	16	1	92006-5	VALVE: BALL 1" NPT
3	1	92036	VALVE: SSOV 1" NPT	23	1	61002-12	HIGH GAS PRESSURE SWITCH 4.7" W.C.
4	1	64048	ACTUATOR: SSOV W/ REGULATOR	25	3	92077	1/4" NPT MXF BRASS BALL VALVE
6	2	12951-2	BUSHING: CONTROL BOX	27	1	99017	SNUBBER: PRESSURE: 1/4"
7	1	61002-1	LOW PRESSURE SWITCH: 2.6" W.C. FALL N.O.	29	1	97087-20	TUBE: FLEXIBLE GAS 20" (50.8 cm) LG
13	2	9-22	PIPE PLUG: 1/4" NPT: STEEL	30	1	99015	DAMPING ORIFICE: SSOV

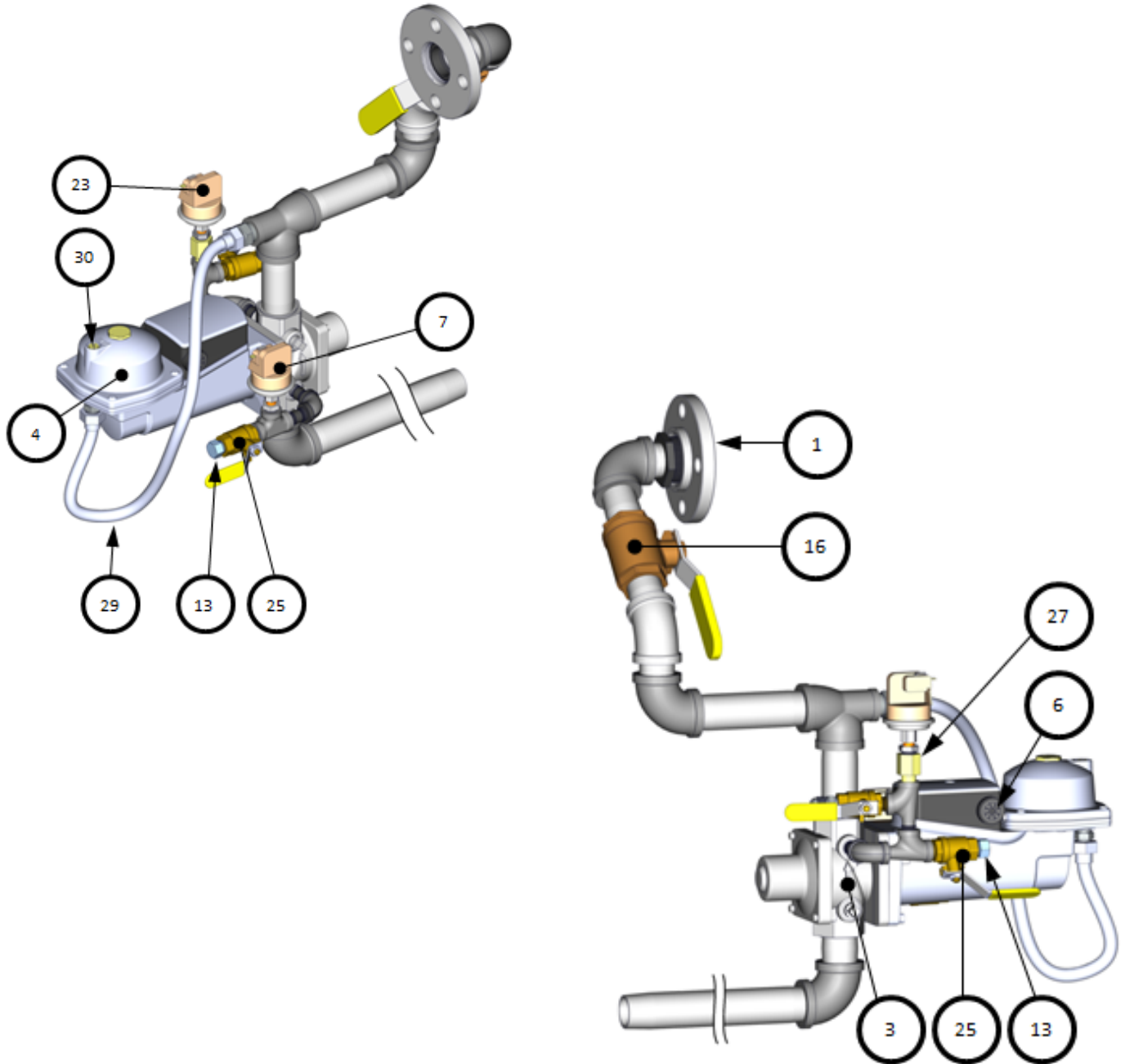

AERCO International, Inc. Blauvelt, NY 10913	Benchmark 750-1000 FM Gas Train	04/11/2017
	22140-1 rev G	Sheet 1 of 1

Benchmark 750-1000 DBB Gas Train – P/N 22140-2

Item	Qty	Part #	Description	Item	Qty	Part #	Description
1	1	95026	1.25" NPT 125#: THREADED FLANGE	16	1	92006-5	VALVE: BALL 1" NPT
3	2	92036	VALVE: SSOV 1" NPT	18	1	27086-1	ACTUATOR: SSOV w/o P.O.C. SWITCH
4	1	64048	ACTUATOR: SSOV W/ REGULATOR	19	1	61002-12	HIGH GAS PRESSURE SWITCH 4.7" W.C.
6	4	12951-2	BUSHING: CONTROL BOX	21	1	122774	VALVE: VENT 3/4" NPT
7	1	61002-1	LOW PRESSURE SWITCH: 2.6" W.C. FALL N.O.	23	1	99017	SNUBBER: PRESSURE: 1/4"
8	1	99015	DAMPING ORIFICE: SSOV	33	3	92077	1/4" NPT MXF BRASS BALL VALVE
13	2	9-22	PIPE PLUG: 1/4" NPT: STEEL	36	1	97087-20	TUBE: FLEXIBLE GAS 20" (50.8 cm) LG

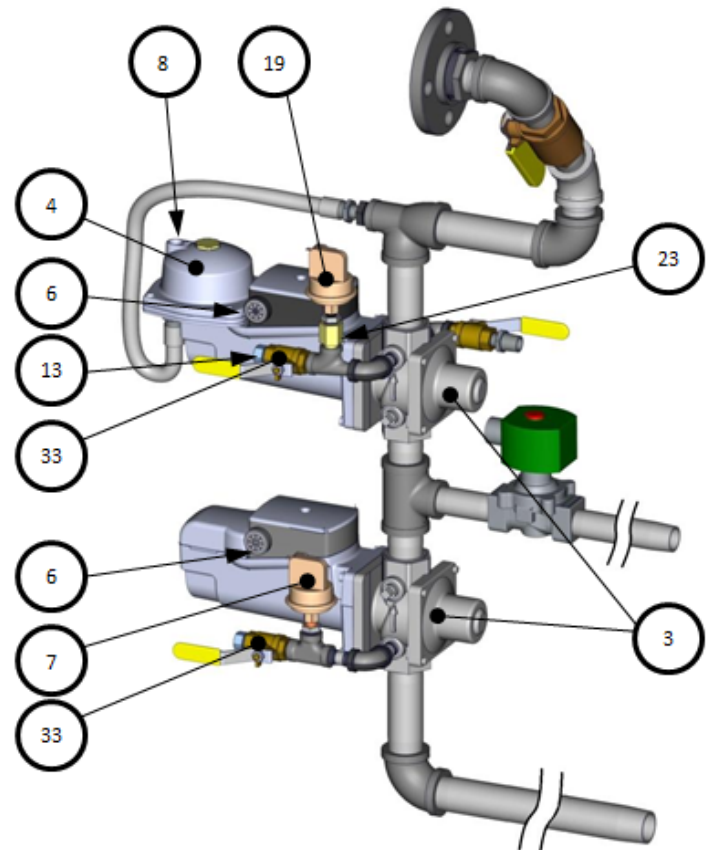
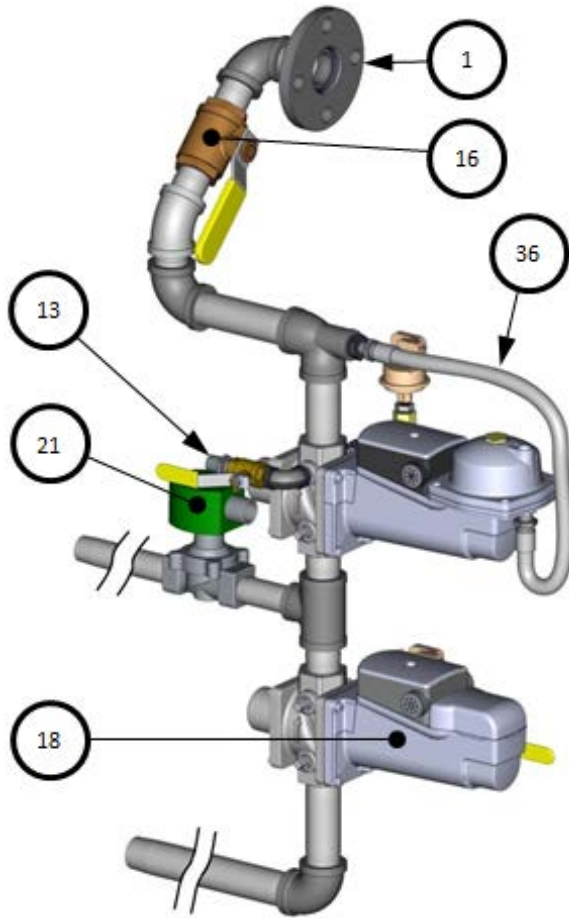

AERCO International, Inc. Blauvelt, NY 10913	Benchmark 750-1000 DBB Gas Train	10/15/2015
	22140-2 rev E	Sheet 1 of 1

APPENDIX F – BENCHMARK 750/1000 PART LISTS

BMK 750-1000 PROPANE Gas Train – P/N 22140-3							
Item	Qty	Part #	Description	Item	Qty	Part #	Description
1	1	95026	THREADED FLANGE: 1.25" NPT 125#	24	1	92006-3	VALVE: FULL PORT BALL 1/2" NPT BRASS
2	1	92103	VALVE: SSOV 1/2" NPT	25	3	92077	1/4" NPT MXF BRASS BALL VALVE
3	1	64048	ACTUATOR: SSOV W/ REGULATOR	29	1	93474	REDUCING COUPLING 1 X 1/2"
11	1	93420	UNION 1/2" NPT FEMALE BLACK MI	31	1	99017	SNUBBER: PRESSURE: 1/4"
12	2	9-22	PIPE PLUG: 1/4" NPT: STEEL	32	1	97087-20	TUBE, FLEXIBLE GAS 20"
23	2	12951-2	BUSHING: CONTROL BOX	33	1	99015	DAMPING ORIFICE: SSOV

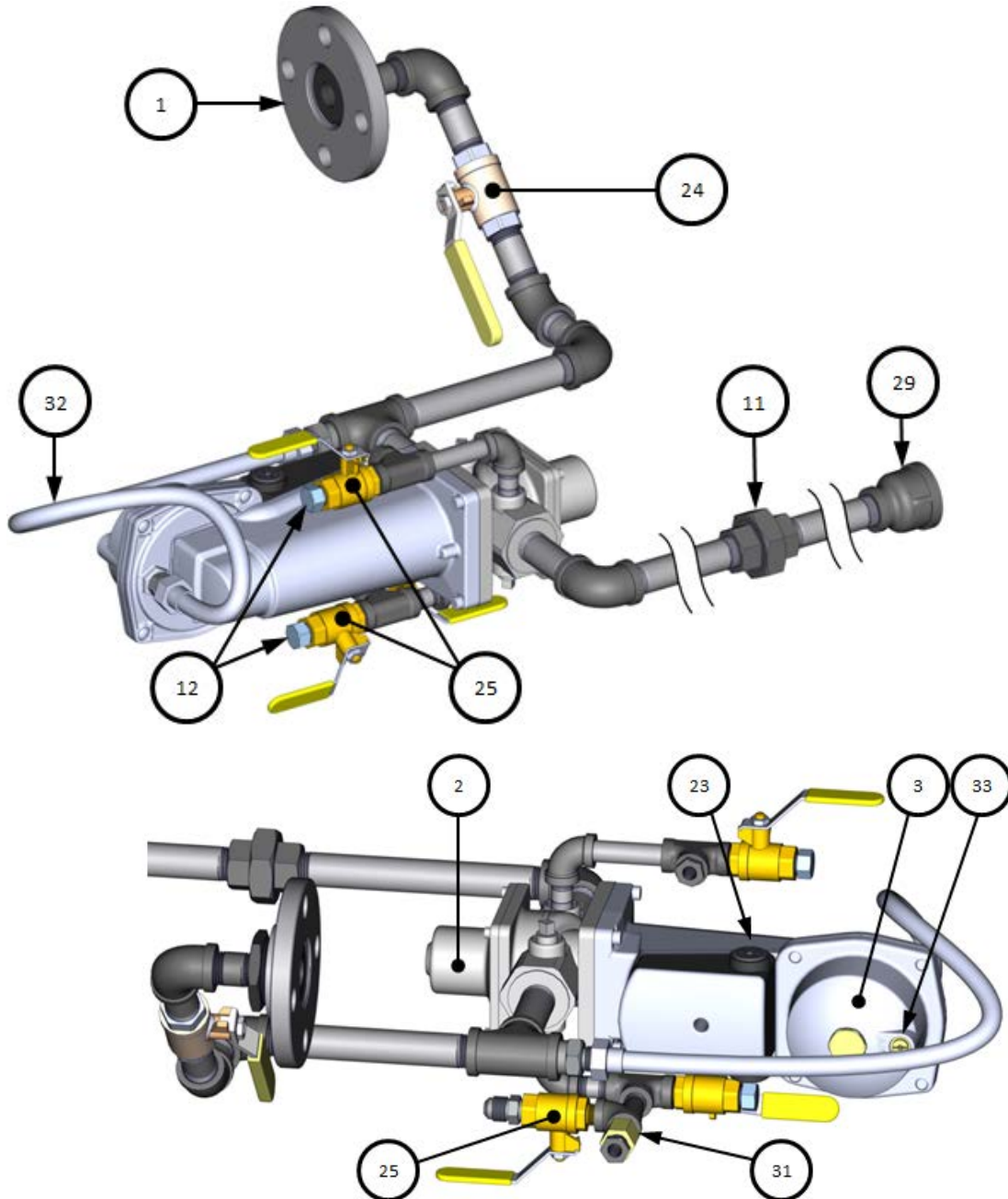

AERCO International, Inc. Blauvelt, NY 10913	Benchmark 750-1000 Gas Train – Propane	04/11/2017
	22140-3 rev H	Sheet 1 of 1

Benchmark 750-1000 Burner, Blower, Air/Fuel Valve – P/N 24276-TAB

Item	Qty	Part #	Description	Item	Qty	Part #	Description
1	1	42140	PLATE: BURNER	12	3	53033	WASHER: CLOCKING
2	1	81143	GASKET: BURNER	13	1	46026	BURNER: BMK 1.0
3	1	81064	GASKET: BLOWER	15	1	See Table	A/F VALVE ASSY
4	1	24111	BLOWER: AMETEK 8.9"	17	1	61002-5	BLOCKED INLET SWITCH -4.5" W.C.
5	1	59104	OBSERVATION PORT	18	1	59171	REFLECTOR: SIGHT GLASS
6	1	24277	STAGED IGNITION ASSY	19	1	61026	O ₂ SENSOR
7	1	66034	FLAME ROD	23	1	66026	IGNITOR-INJECTOR
8	1	88004	O-RING #2-244 BUNA-N	24	1	9-21	PLUG: HEX HD 1/8 NPT
9	1	81048	GASKET: FLAME ROD LOW NO _x	25	1	123449	AIR INLET TEMPERATURE SENSOR
11	1	60011-4	SWITCH ASSY: BLOWER PROOF				

Part #	Qty	Item 15	Description
24276	1	24298	A/F VALVE ASSY BMK 1000
24276-1		24298-1	A/F VALVE ASSY BMK 750
24276-2		24298-2	A/F VALVE ASSY BMK 750/1000 PROPANE

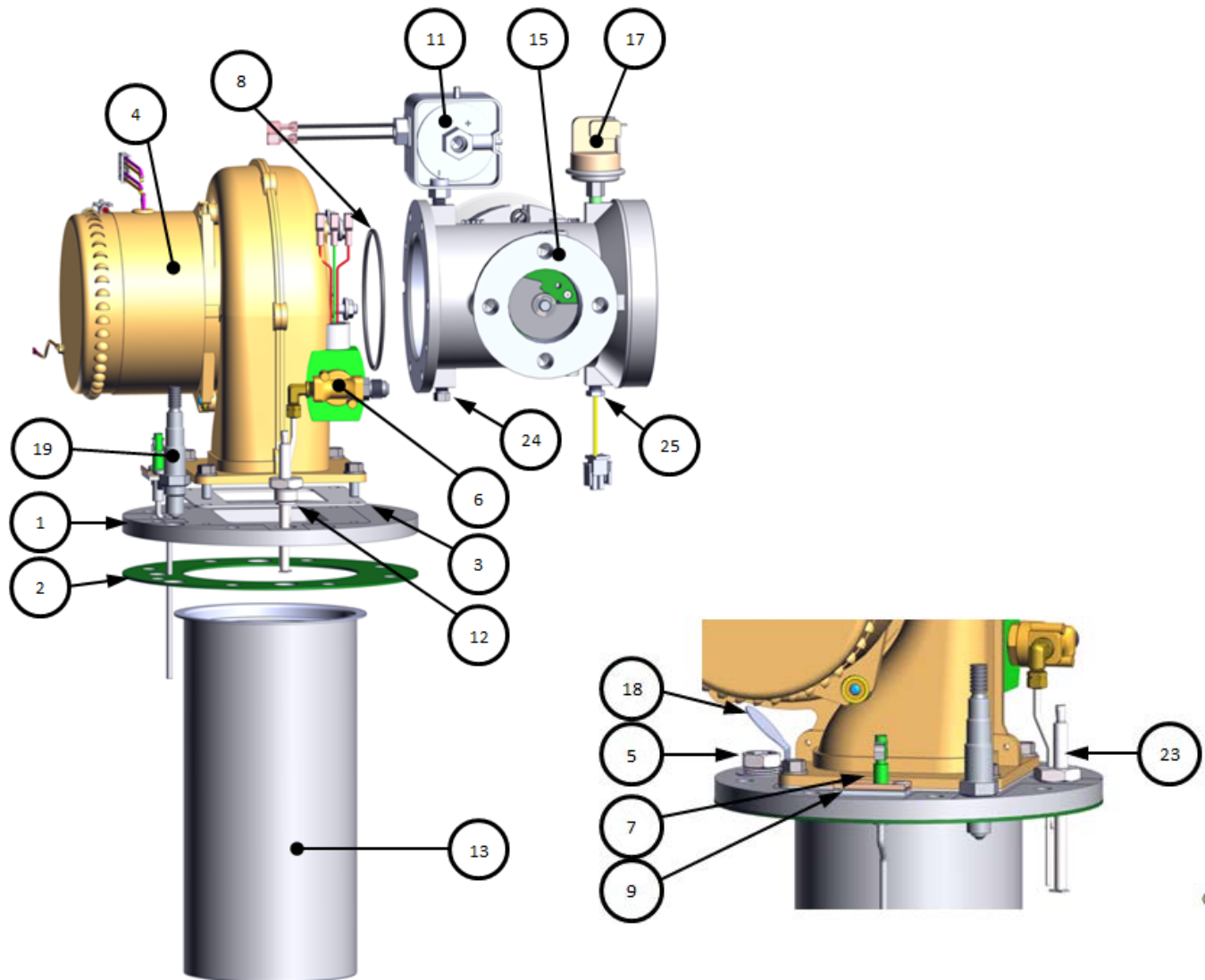

AERCO International, Inc. Blauvelt, NY 10913	Benchmark 750-1000 Burner Assembly	09/11/2018
	BMK 750/1000 24276-TAB Rev K	Sheet 1 of 1

Appendix G: Benchmark PLATINUM 1500/2000 Part Lists

Benchmark 1500/1500DF & 2000/2000DF Part List

Item #	Qty	Part #	Description
EXHAUST MANIFOLD			
1	1	39187	EXHAUST MANIFOLD
2	1	81165	EXHAUST MANIFOLD SEAL
3	1	9-22	PIPE PLUG - EXHAUST MANIFOLD
GAS TRAIN ASSEMBLY			
4	1	22188	BMK 1500 STANDARD GAS TRAIN
		22199	BMK 1500-2000 DBB GAS TRAIN
		22198	BMK 1500/2000 GAS TRAIN Dual Fuel
		22201	BMK 1500/2000 GAS TRAIN Dual Fuel DBB
BURNER, AIR/FUEL VALVE, HEAT EXCHANGER			
8	1	24378	BMK 1500 BURNER ASSY
		24378-1	BMK 2000 BURNER ASSY
		24378-2	BMK 2000 BURNER ASSY Dual Fuel
10	1	46042	BURNER, BMK 1500
		46044	BURNER, BMK 2000
11	1	24277	STAGED IGNITION ASSY
14	1	43090	AIR FUEL VALVE PLENUM
15	1	24311-3	AIR/FUEL VALVE ASSY, BMK 1500, Replacement Kit
		24311-10	AIR/FUEL VALVE ASSY, BMK 2000, Replacement Kit
HOSES & INSULATION			
16	1	97087-72	FLEX GAS TUBE 72" (1.83 m)
17	1	80089	SHELL INSULATION
BLOWER			
18	1	58038	BLOWER Replacement Kit
21	1	24356-1	FLAME DETECTOR KIT - Replacement Kit
22	1	61026	LEAN OXYGEN SENSOR
24	1	58023	IGNITER-INJECTOR Replacement Kit
25	1	59138	AIR FILTER, 6"
26	1	43095	BLOWER PLENUM, BMK 1500-2000
CONTROLS			
27	1	123966	SWITCH: OVER TEMP-AUTO RESET
28	1	123552	SWITCH: OVER TEMP-MANUAL RESET
29	1	60011-4	BMK 1500 BLOWER PROOF SWITCH
		60011-2	BMK 2000 BLOWER PROOF SWITCH
30	1	61002-5	BLOCKED INLET SWITCH -4.5" W.C.
31	1	69186-4	C-MORE CONTROLLER
32	1	65085	IGNITION TRANSFORMER
34	1	93230	SNUBBER - AIR/FUEL VALVE
35	1	64081	ECU, O ₂ SENSOR
36	1	65011	TRANSFORMER 115V/24V 100VA
37	1	65109	12V POWER SUPPLY
38	3	69141	DIN RAIL MOUNT END STOP
39	2	65120	TERMINAL BLOCK: DIN MOUNTED: BLK

40	2	65121	TERMINAL BLOCK: DIN MOUNTED: WHT
41	3	65122	TERMINAL GROUND BLOCK: DIN MOUNTED
42	2	65118	FUSE TERMINAL: DIN MOUNTED
43	1	64088	LIMIT CONTROL TEMPERATURE, DIGITAL CONTROLLER
44	1	60026	CIRCUIT BREAKER
45	1	65156	FLAME DETECTOR SIGNAL AMPLIFIER
46	1	65162	24V POWER SUPPLY (Sequencing Valve)
47	2	124512	FUSE: 4 AMP
48	2	123449	SENSOR: TEMPERATURE
49	1	58132	THERMOWELL Replacement Kit
51	1	63035-1	FUEL SELECTOR SWITCH & HARNESS (Dual Fuel Only)
52	1	69227	ONAER COMMUNICATION BOARD
54	1	33170	MOUNTING PANEL
55	1	124324	GROUND BAR
59	1	123449	AIR INLET TEMPERATURE SENSOR
60	1	69102-3	PUMP RELAY
61	1	61030	SENSOR: OUTLET TEMPERATURE
62	1	69172	INPUT/OUTPUT (PCB) ASSY
63	1	67009	THERMOMETER, DIAL
67	1	61034	SPARK MONITOR (Current Transducer)
68	1	65147	EBM 12VDC AXIAL VENT FAN (Dual Fuel only)
SHEET METAL/PANEL ASSEMBLY			
70	1	38035	I/O PANEL COVER
71	1	38036	POWER PANEL COVER
72	1	37157	BACK PANEL: RIGHT (Black)
73	1	37158	BACK PANEL: LEFT (Black)
74	2	35047	TOP RAIL (Black)
75	1	25087	FRONT FRAME ASSEMBLY (Black)
76	1	25086	FRONT PANEL ASSEMBLY(Platinum)
79	4	59133	LATCH, COMPRESSION
80	1	37159	TOP PANEL: FRONT (Black)
81	1	37160	TOP PANEL: BACK (Black)
82	2	30155	SIDE PANEL (Black)
84	1	39215	8" AIR INLET ADAPTER, BMK 2000 (Black)
		39218	6" AIR INLET ADAPTER, BMK 1500 (Black)
OTHER ACCESSORIES & PARTS			
90	1	69126	LOW WATER CUTOFF CAPACITOR FRU Kit
91	1	123863	1/8" NTP BALL VALVE
92	1	92094	3/4" DRAIN VALVE
95	1	59178	1/8" AIR VENT

❶ Not shown on drawing

AERCO International, Inc. Blauvelt, NY 10913	Benchmark 1500/1500DF, 2000/2000DF Part List	10/02/2017
	Benchmark 1500 29313-TAB rev G Benchmark 2000 29337-TAB rev G	Sheet 1 of 9

Spare Parts Kits: BMK 1500 P/N 58088-TAB, BMK 2000 P/N 58087-TAB

Part #	Description
123540	External 2" Ball Valve
24441	Condensate Trap
See Table Below	Pressure Relief Valve
See Table Below	Pressure/Temp Gauge

Benchmark 1500 Spare Parts Kits P/N 58088-TAB				Benchmark 2000 Spare Parts Kits P/N 58087-TAB			
Kit Number *	Description	Pressure Relief Valve	Pressure/Temp Gauge	Kit Number *	Description	Pressure Relief Valve	Pressure/Temp Gauge
58088-C30	30 PSI (207 kPa) KIT (CONBRACO)	92023-1	123675-5	58087-1	30 PSI (207 kPa)	123620-W30	123675-5
58088-C50	50 PSI (345 kPa) KIT (CONBRACO)	92023-2	123675-5	58087-2	50 PSI (345 kPa)	123620-W50	123675-5
58088-C60	60 PSI (414 kPa) KIT (CONBRACO)	92023-3	123675-6	58087-3	75 PSI (517 kPa)	123620-W75	123675-6
58088-C75	75 PSI (517 kPa) KIT (CONBRACO)	92023-4	123675-6	58087-4	100 PSI (689 kPa)	123620-W100	123675-6
58088-C100	100 PSI (689 kPa) KIT (CONBRACO)	92023-5	123675-6	58087-5	150 PSI (1034 kPa)	123620-W150	123675-7
58088-C125	125 PSI (862 kPa) KIT (CONBRACO)	92023-6	123675-6	58087-6	60 PSI (414 kPa)	123620-W60	123675-6
58088-C150	150 PSI (1034 kPa) KIT (CONBRACO)	92023-7	123675-7	58087-7	125 PSI (862 kPa)	123620-W125	123675-6
58088-W30	30 PSI (207 kPa) KIT (WATTS)	92023-8	123675-5	58087-8	160 PSI (1103 kPa)	123620-K160	123675-7
58088-W50	50 PSI (345 kPa) KIT (WATTS)	92023-9	123675-5	58087-9	40 PSI (276 kPa)	92015-45	123675-5
58088-W60	60 PSI (414 kPa) KIT (WATTS)	92023-10	123675-6				
58088-W75	75 PSI (517 kPa) KIT (WATTS)	92023-11	123675-6				
58088-W100	100 PSI (689 kPa) KIT (WATTS)	92023-12	123675-6				
58088-W125	125 PSI (862 kPa) KIT (WATTS)	92023-13	123675-6				
58088-W150	150 PSI (1034 kPa) KIT (WATTS)	92023-14	123675-7				
58088-K160	160 PSI (1103 kPa) KIT (KUNKLE)	92023-15	123675-7				

* For Dual Fuel units add "DF" to the part number (i.e., 58088-C30-DF)

Wiring Harnesses (not shown in figures below)

Part #	Description
63057	HARNESS: BLOWER POWER
63058	HARNESS: BLOWER SIGNAL
63083	HARNESS: O2 SENSOR
63090	HARNESS, TEMP LIMIT CONTROL
63103	HARNESS: SHELL
63104	HARNESS: I/O INTERLOCK
63105	HARNESS: I/O SENSOR/COMM
63111	HARNESS: CONTROL
63134	VENT FAN POWER WIRE – DUAL FUEL ONLY
63150	HARNESS: FLAME DETECTOR
63156	POWER CABLE, 24V SEQUENCE VALVE
65104	CABLE, H.V. IGNITION

Additional Benchmark 1500/2000 Kits Available

Part #	Description
27086-1	ACTUATOR: SSOV w/o P.O.C. SWITCH Replacement Kit
64048	SSOV WITH PRESSURE REGULATOR Replacement Kit

Other Accessories / Parts (Optional)

Part #	Description
92084-6	MOTORIZED SEQUENCING VALVE

AERCO International, Inc. Blauvelt, NY 10913	Benchmark 1500/1500DF, 2000/2000DF Part List	10/02/2017
	Benchmark 1500 29313-TAB rev G Benchmark 2000 29337-TAB rev G	Sheet 2 of 9

APPENDIX G – BENCHMARK PLATINUM 2500/3000 PART LISTS

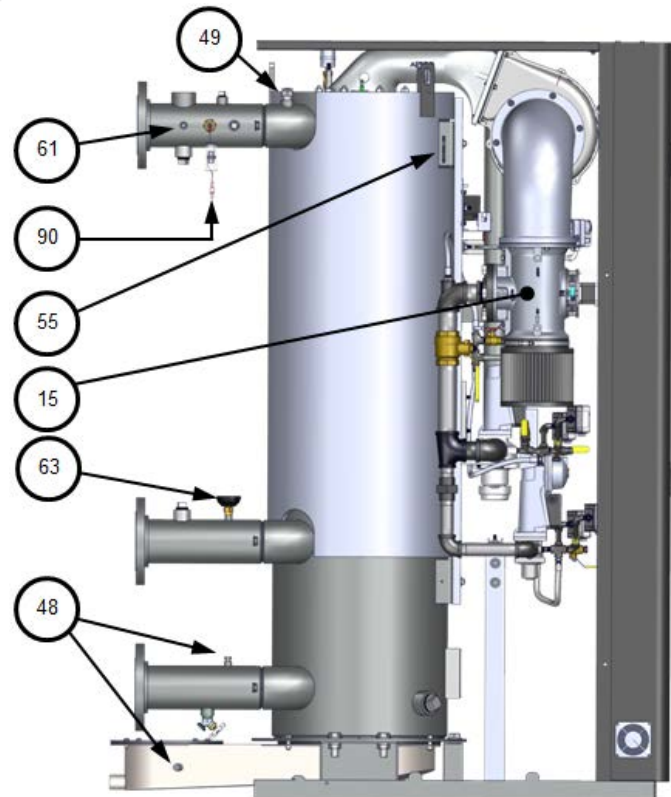
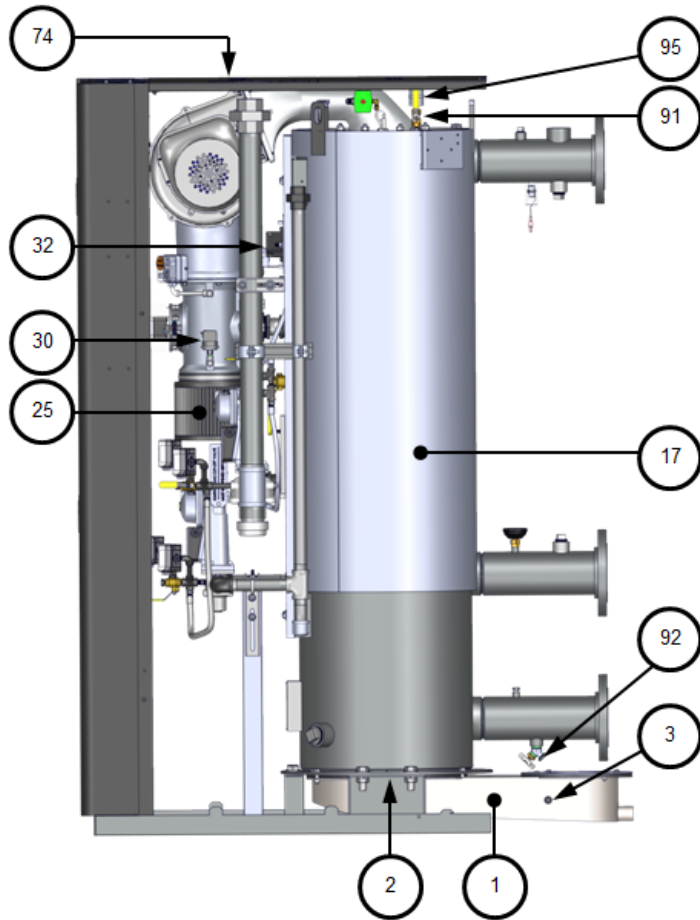

AERCO International, Inc. Blauvelt, NY 10913	Benchmark 1500/1500DF, 2000/2000DF Part List	10/02/2017
	Benchmark 1500 29313-TAB rev G Benchmark 2000 29337-TAB rev G	Sheet 3 of 9

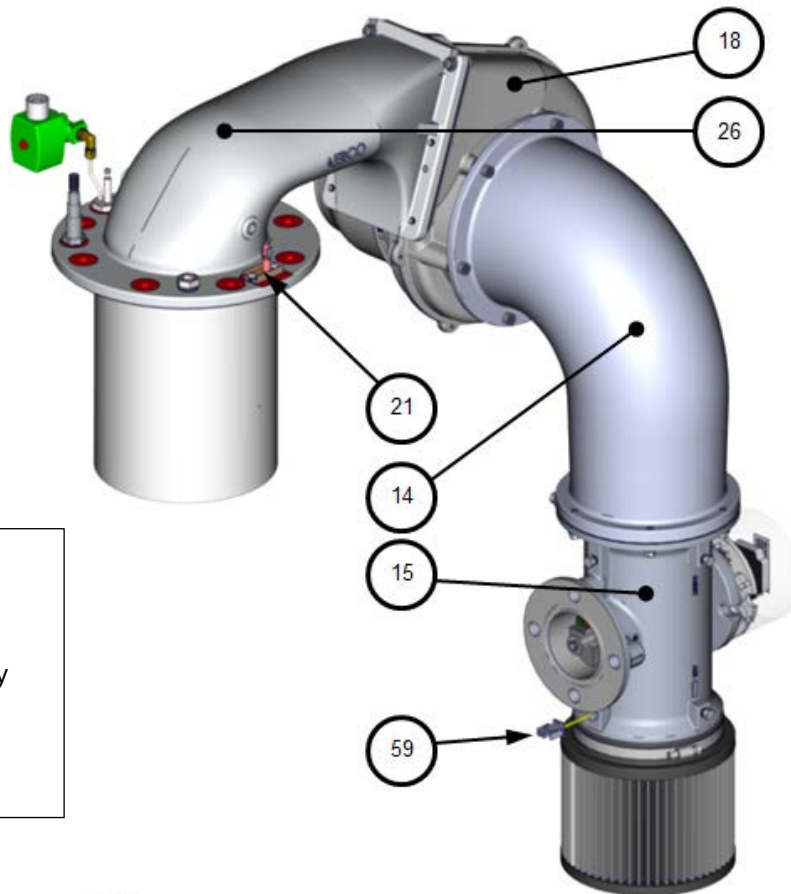

8

Benchmark 1500/2000
 Burner-Air/Fuel Valve Assembly
 P/N 24378 & 24378-1

Full part lists below

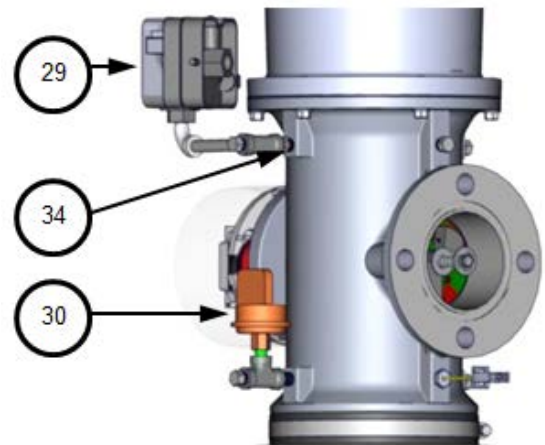
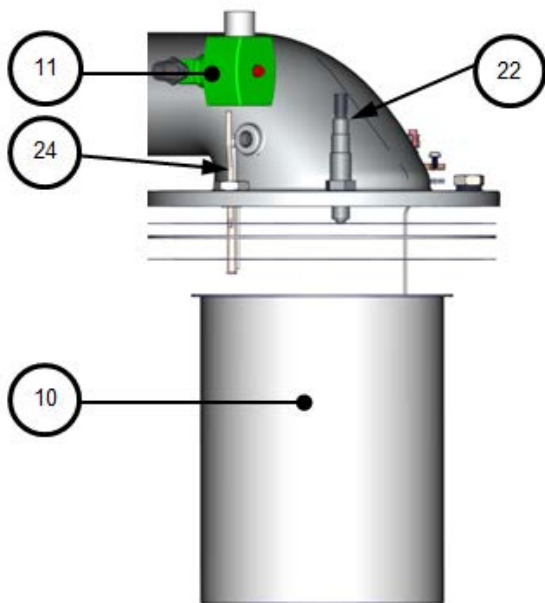

AERCO International, Inc. Blauvelt, NY 10913	Benchmark 1500/1500DF, 2000/2000DF Part List	10/02/2017
	Benchmark 1500 29313-TAB rev G Benchmark 2000 29337-TAB rev G	Sheet 4 of 9

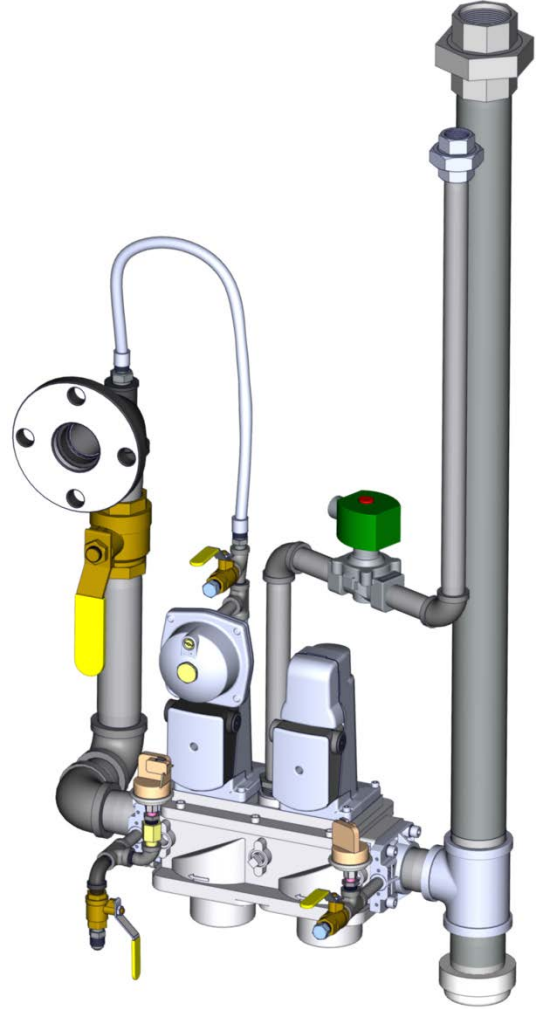
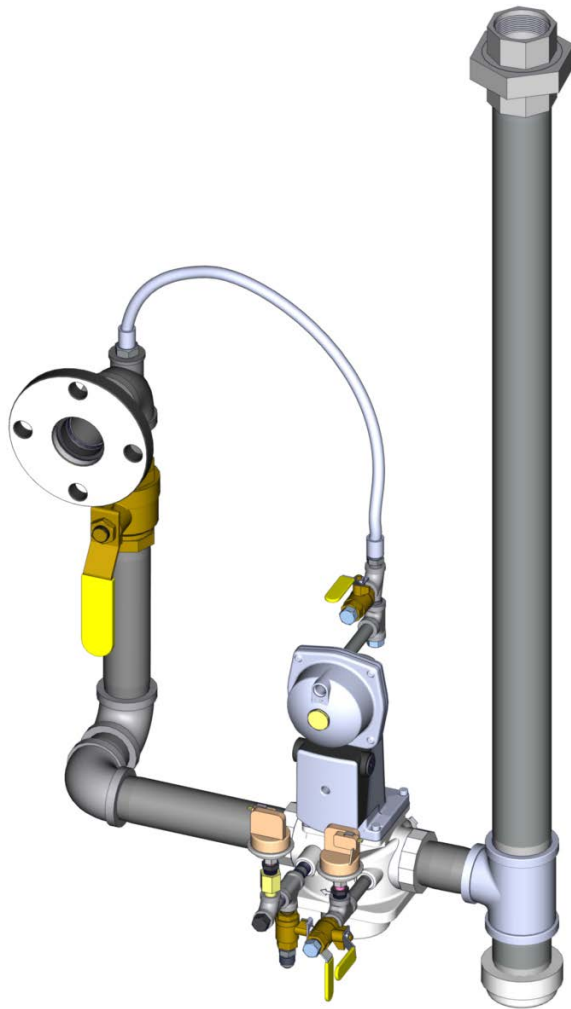

4

Benchmark 1500/2000
 Standard FM Gas Train
 P/N 22188

See full part lists below

4

Benchmark 1500/2000
 Double Block & Bleed Gas Train
 P/N 22199

See full part lists below

AERCO International, Inc. Blauvelt, NY 10913	Benchmark 1500/1500DF, 2000/2000DF Part List	10/02/2017
	Benchmark 1500 29313-TAB rev G Benchmark 2000 29337-TAB rev G	Sheet 5 of 9

4

Benchmark 1500DF/2000DF
 DUAL FUEL Gas Train
 P/N 22198 consists of:

- 22188-1 NATURAL GAS gas train
- 22197 PROPANE train

Full gas train part lists are shown below

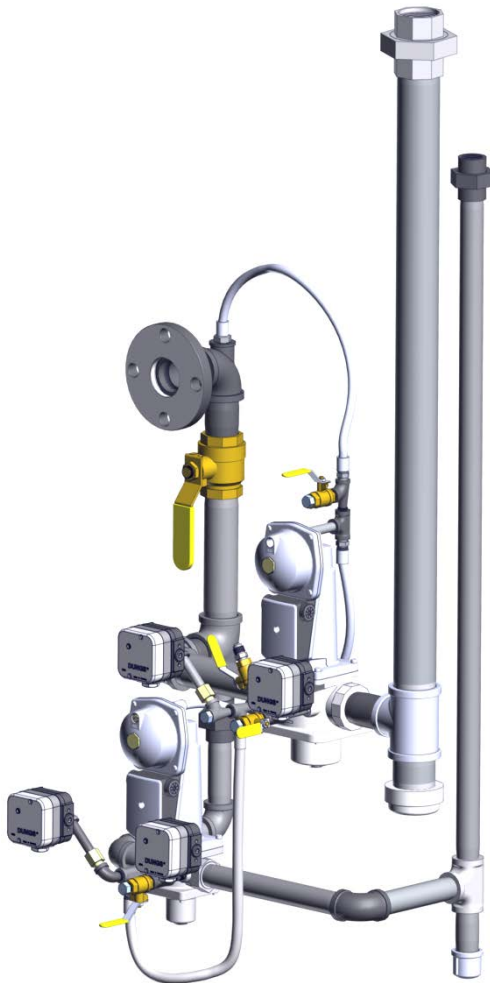

PROPANE
 Gas Train
 P/N 22197



NATURAL GAS
 Gas Train
 P/N 22188-1

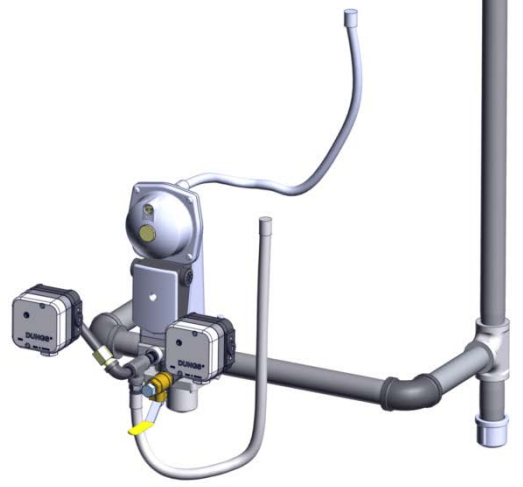

AERCO International, Inc. Blauvelt, NY 10913	Benchmark 1500/1500DF, 2000/2000DF Part List	10/02/2017
	Benchmark 1500 29313-TAB rev G Benchmark 2000 29337-TAB rev G	Sheet 6 of 9

4

Benchmark 1500DF/2000DF
 DUAL FUEL Gas Train P/N **22201**
 consists of:

- **22199-1** NATURAL GAS gas train
- **22200** PROPANE train

Full gas train part lists are shown below



NATURAL GAS
 Gas Train
 P/N **22199-1**

PROPANE
 Gas Train
 P/N **22200**

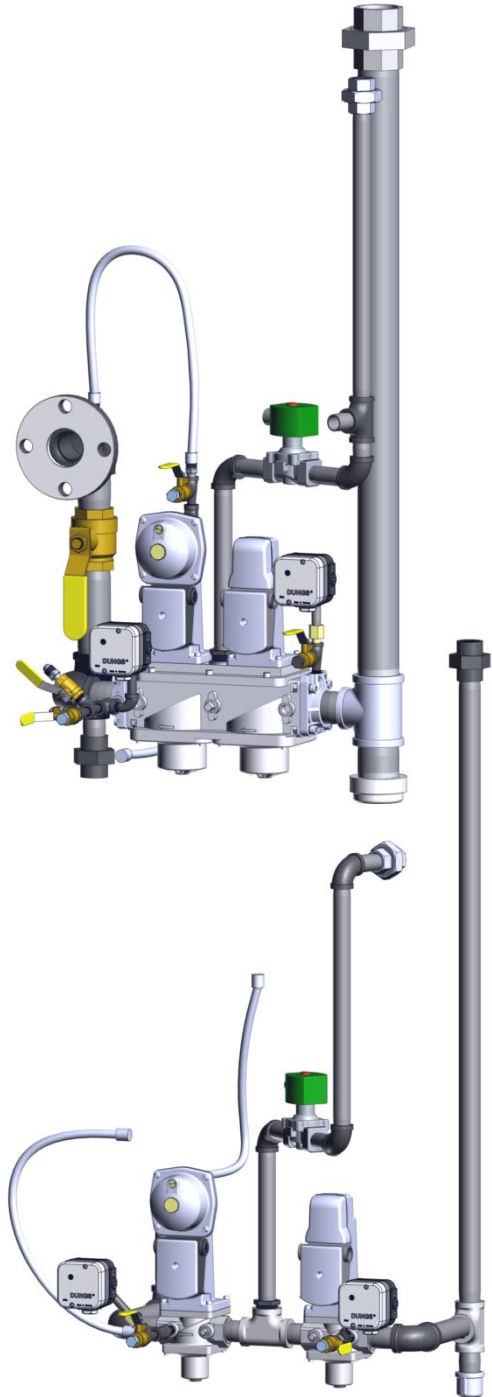

AERCO International, Inc. Blauvelt, NY 10913	Benchmark 1500/1500DF, 2000/2000DF Part List	10/02/2017
	Benchmark 1500 29313-TAB rev G Benchmark 2000 29337-TAB rev G	Sheet 7 of 9

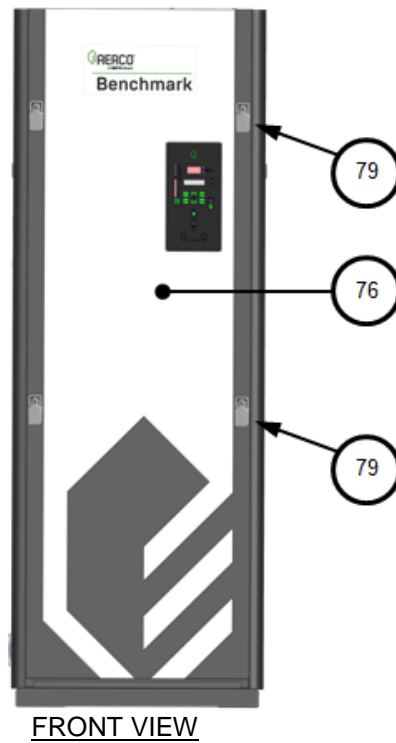
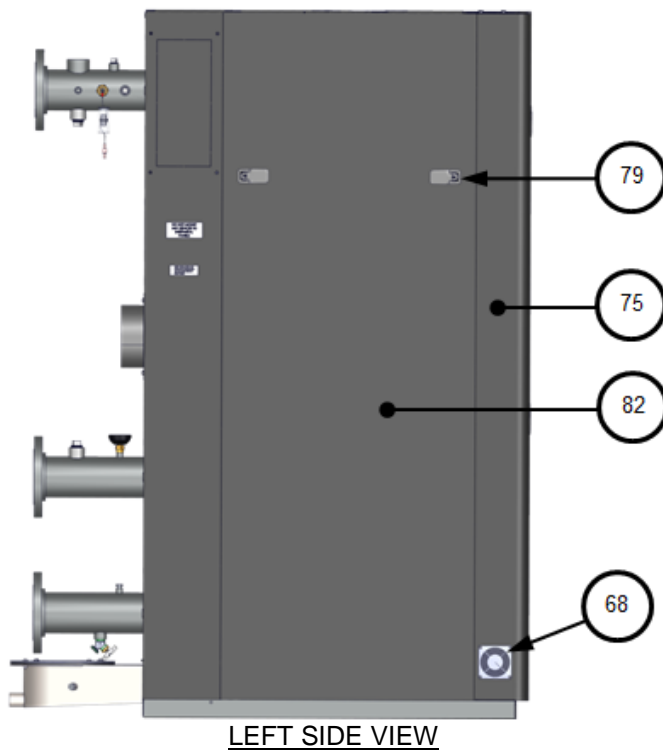
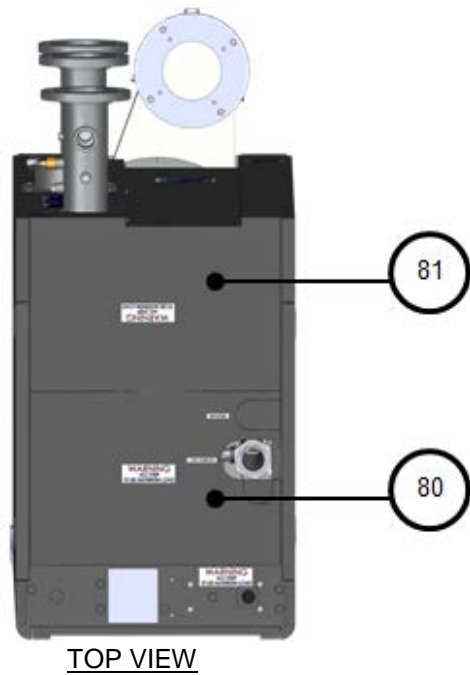
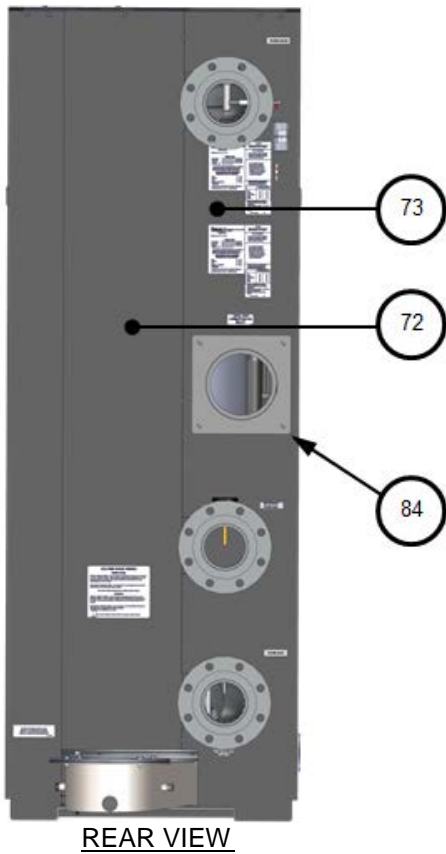

AERCO International, Inc. Blauvelt, NY 10913	Benchmark 1500/1500DF, 2000/2000DF Part List	10/02/2017
	Benchmark 1500 29313-TAB rev G Benchmark 2000 29337-TAB rev G	Sheet 8 of 9

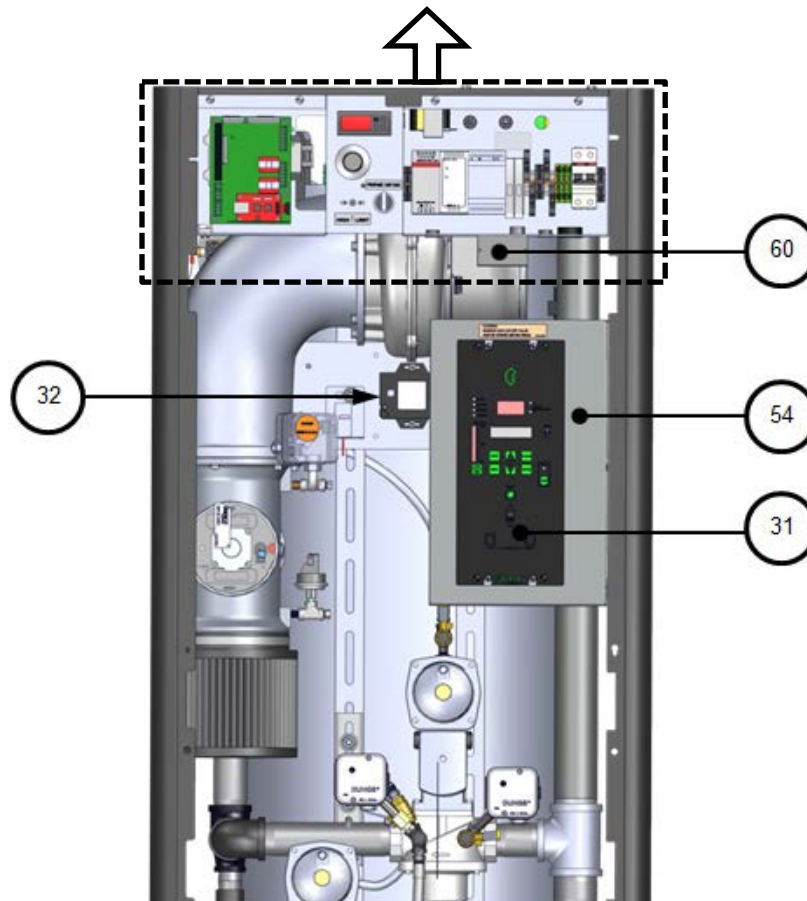
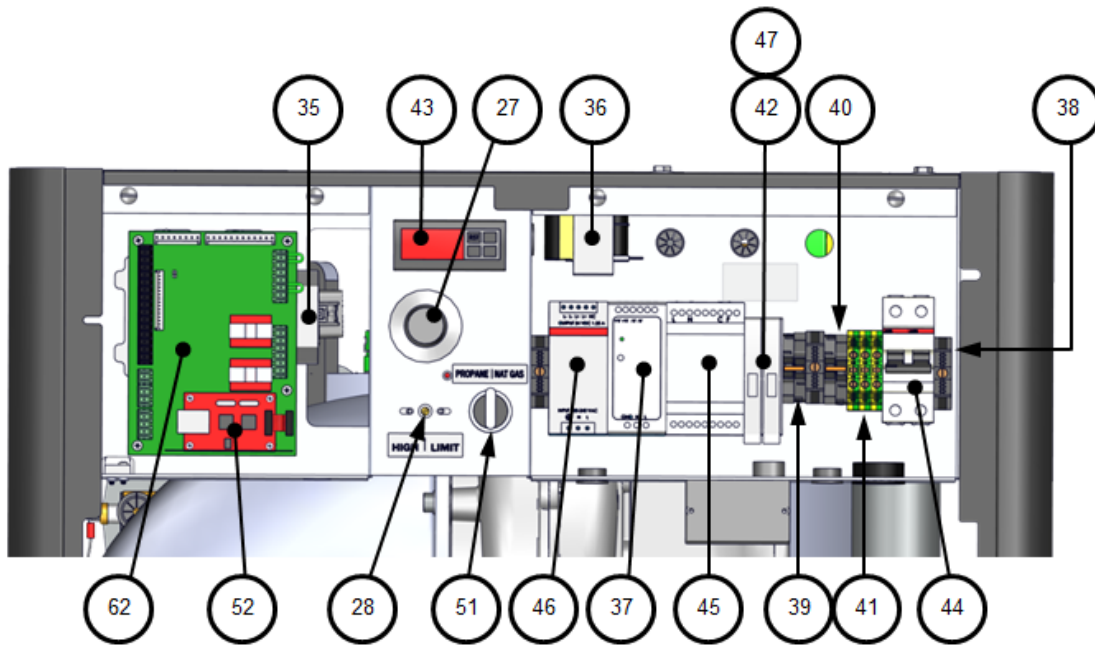

PARTIAL FRONT VIEW

AERCO International, Inc. Blauvelt, NY 10913	Benchmark 1500/1500DF, 2000/2000DF Part List	10/02/2017
	Benchmark 1500 29313-TAB rev G Benchmark 2000 29337-TAB rev G	Sheet 9 of 9

Benchmark 1500-2000 Natural Gas Standard Gas Train – 22188							
Item	Qty	Part #	Description	Item	Qty	Part #	Description
1	1	123542	FLANGE 2" 125# 2"NPT	11	1	97087-20	FLEX HOSE, 20"
4	1	64048	ACTUATOR, SSOV W/ REGULATOR	14	1	61002-11	LOW GAS PRESSURE SWITCH 3.6" W.C.
5	2	12951-2	BUSHING, CONTROL BOX	23	1	124150	VALVE, SSOV 1-1/2" NPT
6	3	92077	1/4" NPT MXF BRASS BALL VALVE	26	1	93382	2" NPT CAP
7	4	9-22	PIPE PLUG, 1/4" NPT, STEEL	28	1	92006-7	VALVE, BALL BRASS 1-1/2" NPT
8	1	99017	SNUBBER, PRESSURE, 1/4"	29	1	9-294	UNION, 2" NPT 300#
9	1	61002-12	HIGH GAS PRESSURE SWITCH 4.7" W.C.				

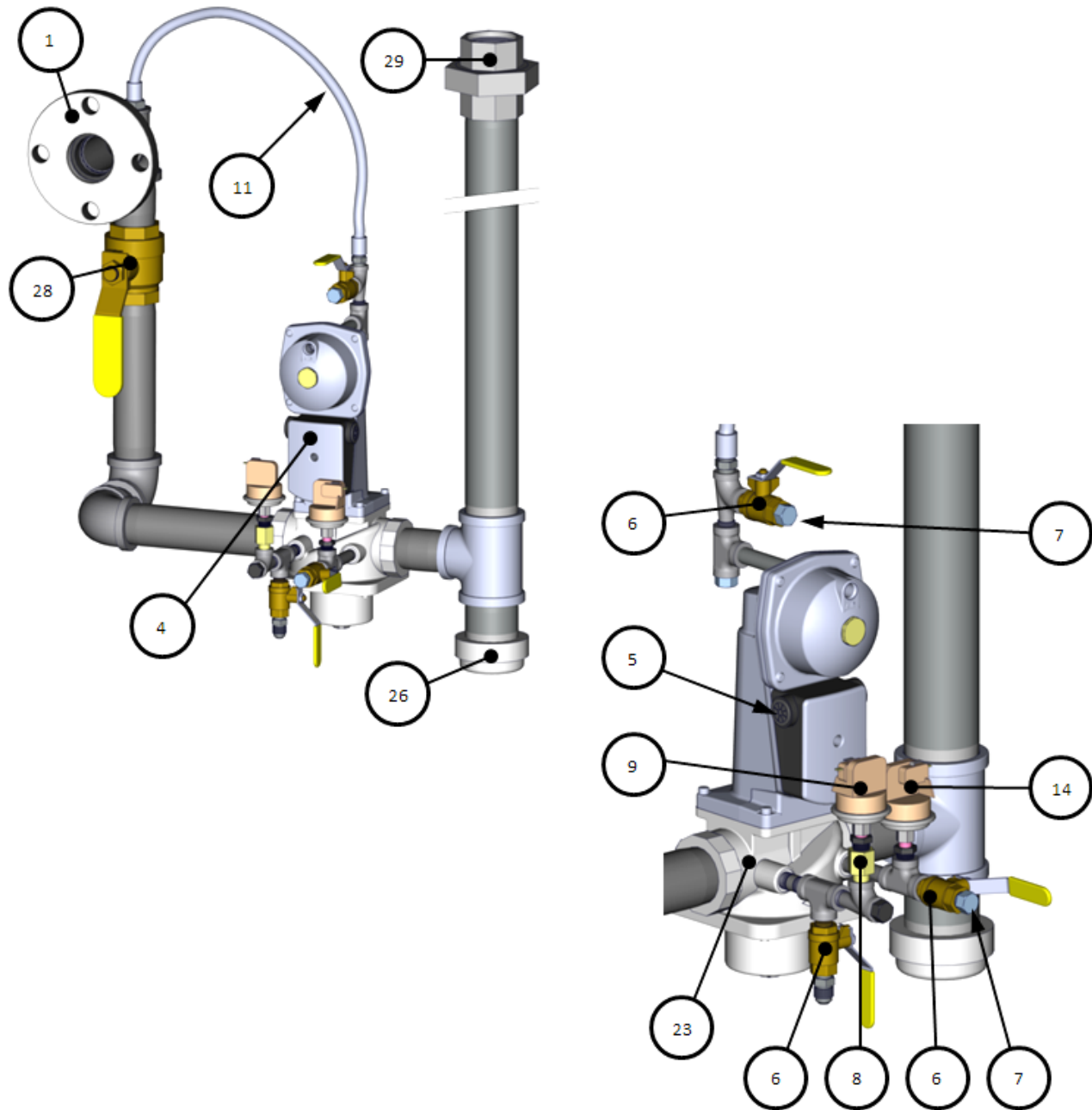

AERCO International, Inc. Blauvelt, NY 10913	Benchmark 1500-2000 Gas Train	05/28/2015
	22188 rev E	Sheet 1 of 1

Benchmark 1500-2000 Natural Gas DBB Gas Train – P/N 22199

Item	Qty	Part No	Description	Item	Qty	Part No	Description
1	1	123542	FLANGE 2" 125# 2" NPT	27	1	124094	UNION, 3/4" NPT #150
4	1	64048	ACTUATOR, SSOV W/ REGULATOR	29	1	122774	VALVE, VENT 3/4" NPT
5	4	12951-2	BUSHING, CONTROL BOX	33	2	95029	FLANGE, SSOV 1 1/2" NPT
6	1	97087-20	TUBING, FLEXIBLE 20"	34	1	99017	SNUBBER, PRESSURE, 1/4"
19	1	93382	2" NPT CAP	36	1	61002-12	HIGH GAS PRESSURE SWITCH 4.7" W.C.
20	1	92006-7	VALVE, BALL BRASS 1-1/2" NPT	37	3	92077	1/4" NPT MXF BRASS BALL VALVE
21	1	9-294	UNION, 2" NPT 300#	39	1	61002-11	LOW GAS PRESSURE SWITCH 3.6" W.C.
22	1	124142	VALVE, SSOV, DOUBLE BODY, 2" NPT	42	3	9-22	PIPE PLUG, 1/4" NPT, STEEL
23	1	27086-1	ACTUATOR, SSOV W/O P.O.C. SWITCH				

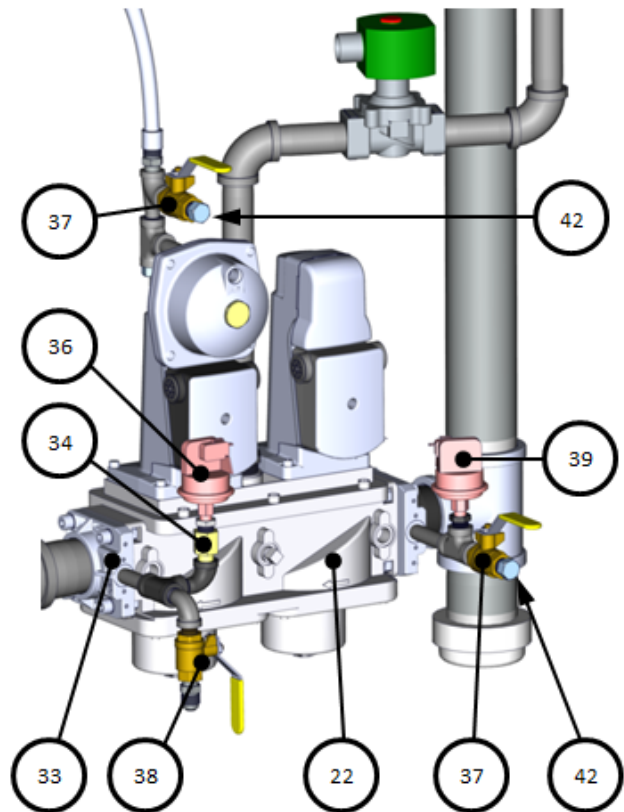
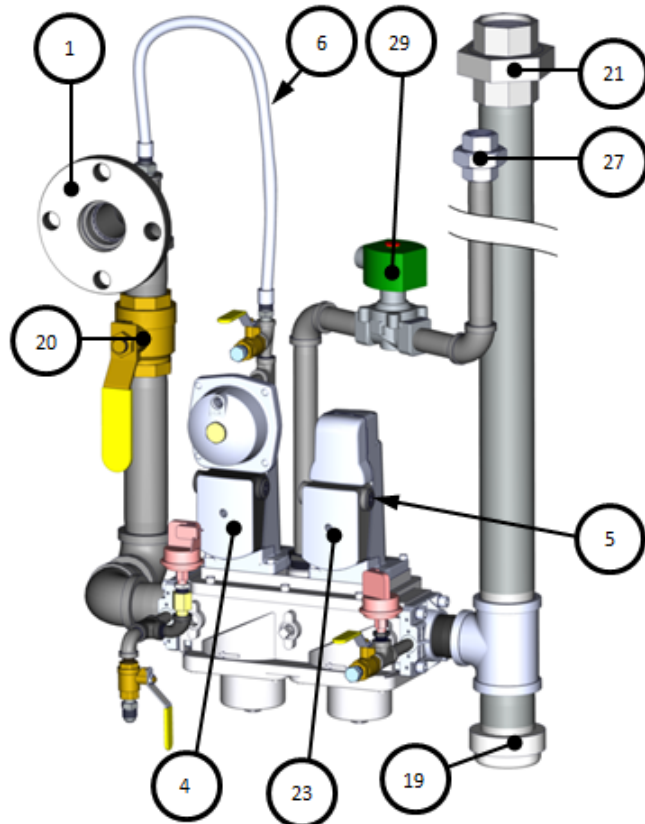

AERCO International, Inc. Blauvelt, NY 10913	Benchmark 1500-2000 DBB Gas Train	11/10/2015
	22199 rev F	Sheet 1 of 1

Benchmark 1500 – 2000 Burner Assembly – P/N 24378-TAB							
Item	Qty	Part #	Description	Item	Qty	Part #	Description
1	1	69078	BLOWER: AMETEK 12.3"	19	1	81166	BURNER GASKET
2	1	43090	AIR FUEL VALVE PLENUM	20	1	66026	IGNITOR-INJECTOR
3	1	See Table	AIR/FUEL VALVE ASSEMBLY	21	1	61026	O ₂ SENSOR
4	1	See Table	BURNER	22	1	81048	GASKET: FLAME ROD LOW NO _x
5	1	81057	GASKET: BLOWER	23	1	66034	FLAME ROD
6	1	43095	BLOWER PLENUM	24	1	59104	OBSERVATION PORT
8	1	59138	FILTER: AIR 6"	25	1	81183	BURNER GASKET: UPPER RELEASE
9	5	9-21	PLUG: HEX HD 1/8 NPT	26	1	24277	STAGED IGNITION ASSY
12	1	123449	AIR INLET TEMPERATURE SENSOR	27	1	81184	GASKET: BLOWER
15	1	See Table	BLOWER PROOF SWITCH ASSEMBLY	32	1	81186	BURNER GASKET: LOWER RELEASE
16	1	61002-5	BLOCKED INLET SWITCH -4.5" W.C.	35	1	53033	WASHER: CLOCKING
17	1	81100	GASKET: BLOWER 12.3"				

Burner Assembly Parts				
Part #	Description	Item 3	Item 4	Item 15
24378	BMK 1500	24220-3	46042	60011-4
24378-1	BMK 2000	24220-10	46044	60011-2
24378-2	BMK 2000 DF	24220-3	46044	60011-2

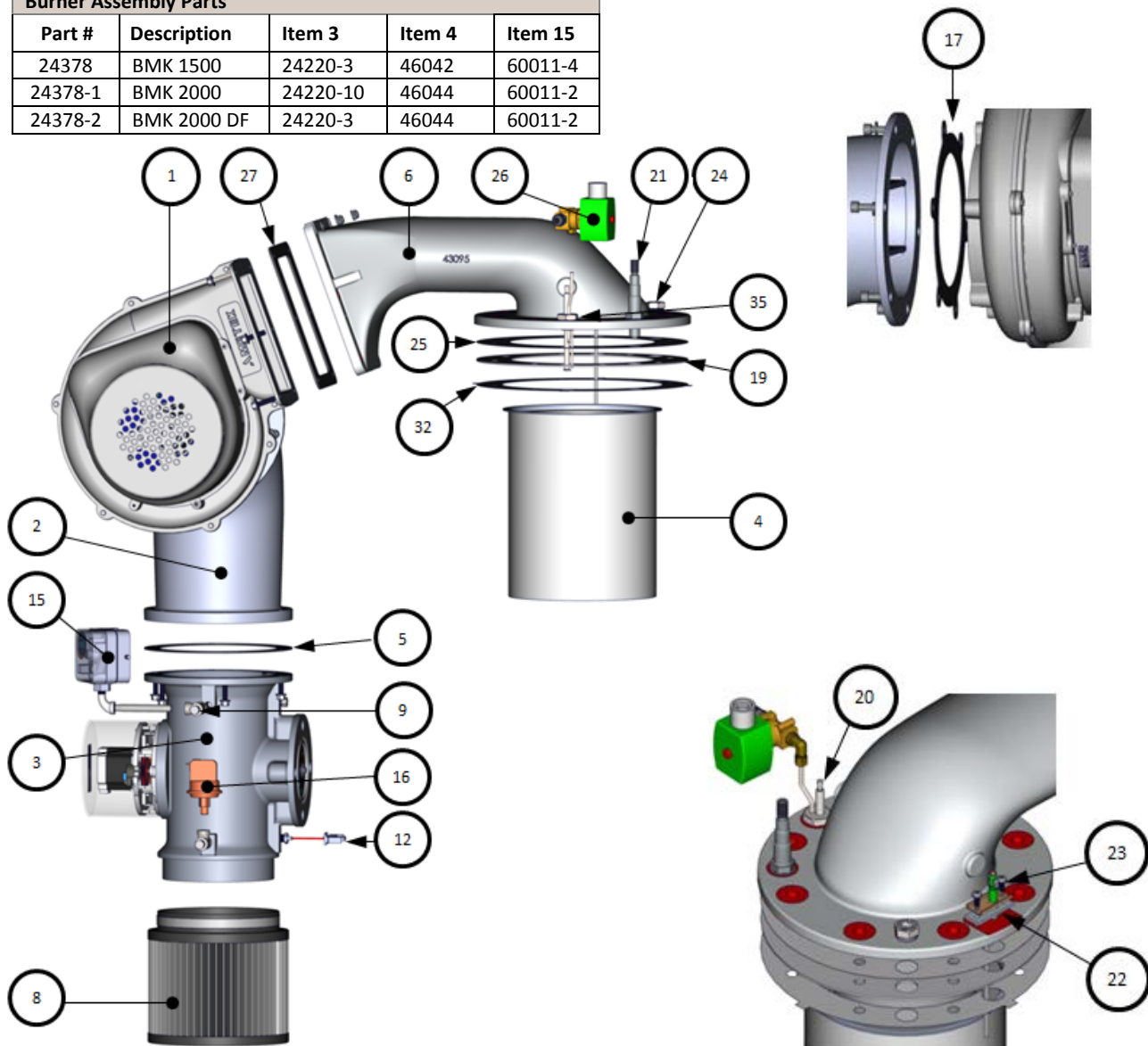

AERCO International, Inc. Blauvelt, NY 10913	Benchmark 1500 - 2000 Burner Assembly	09/13/2018
	24378-TAB rev G	Sheet 1 of 1

Benchmark 1500DF – 2000DF Natural Gas Gas Train – P/N 22188-1

Item	Qty.	Part No.	Description	Item	Qty.	Part No.	Description
1	1	123542	FLANGE 2" 125# 2" NPT	20	1	93382	2" NPT CAP
7	1	64048	ACTUATOR, SSOV W/ REGULATOR	21	1	92006-7	VALVE, BALL BRASS 1-1/2" NPT
8	2	12951-2	BUSHING, CONTROL BOX	22	1	9-294	UNION, 2" NPT 300#
9	3	92077	1/4" NPT MXF BRASS BALL VALVE	24	1	9-291	UNION, 1" NPT 300# BI
10	3	9-22	PIPE PLUG, 1/4" NPT, STEEL	29	2	60020	GAS PRESSURE SWITCH, 2-20" W.C.
11	1	99017	SNUBBER, PRESSURE, 1/4"	31	1	97087-20	FLEX HOSE, 20"
18	1	124150	VALVE, SSOV 1-1/2" NPT				

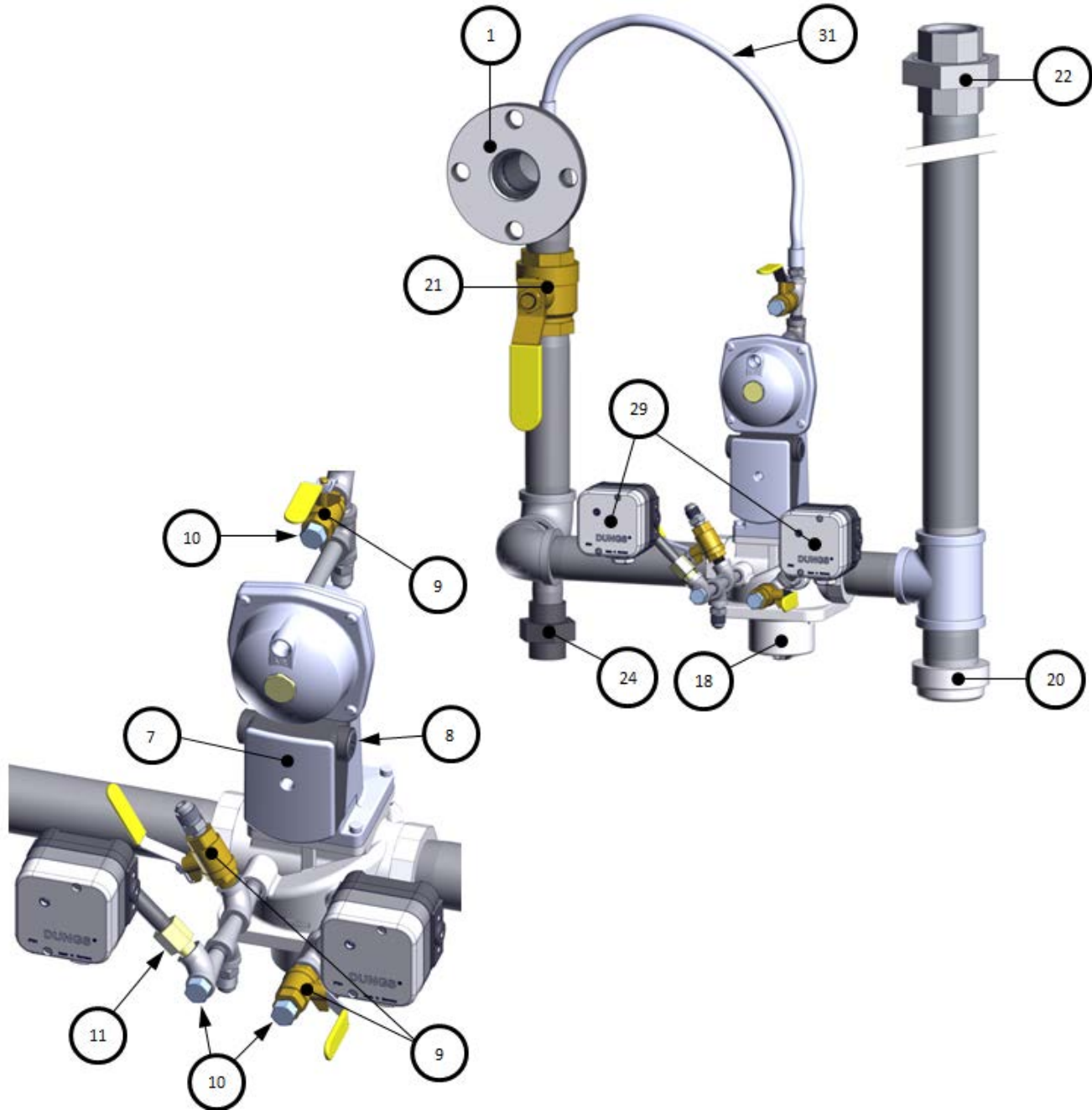

AERCO International, Inc. Blauvelt, NY 10913	Benchmark 1500DF-2000DF Gas Train NATURAL GAS	05/05/2015
	22188-1 rev C, component of 22198	Sheet 1 of 1

Benchmark 1500DF – 2000DF PROPANE Gas Train – P/N 22197

Item	Qty.	Part No.	Description	Item	Qty.	Part No.	Description
1	1	92036	VALVE, SSOV 1" NPT	11	1	99017	SNUBBER, PRESSURE, 1/4"
2	1	64048	ACTUATOR, SSOV W/ REGULATOR	15	1	9-291	UNION, 1" NPT 300# BI
3	2	12951-2	BUSHING, CONTROL BOX	19	1	93466	CAP, 1" NPT M/I
4	1	9-22	PIPE PLUG, 1/4" NPT, STEEL	21	2	60020	GAS PRESSURE SWITCH, 2-20" W.C.
8	1	92077	1/4" NPT MXF BRASS BALL VALVE				

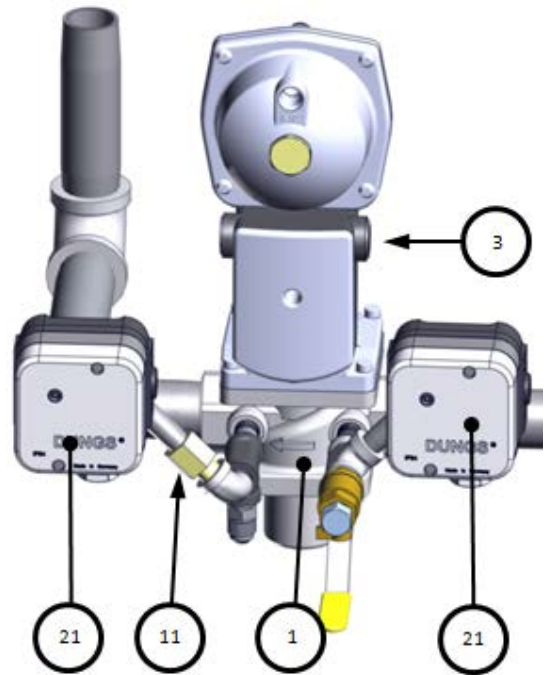
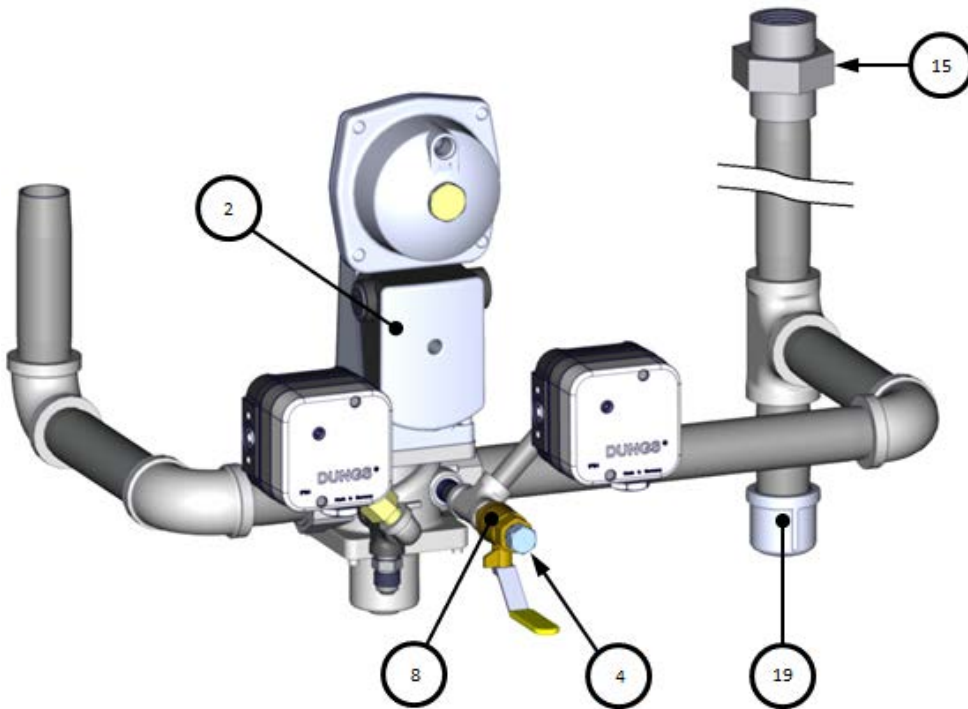

AERCO International, Inc. Blauvelt, NY 10913	Benchmark 1500DF-2000DF PROPANE Gas Train	09/17/2015
	22197 rev D, component of 22198	Sheet 1 of 1

Benchmark 1500DF – 2000DF DBB NATURAL GAS Gas Train – P/N 22199-1

Item	Qty	Part No.	Description	Item	Qty	Part No.	Description
1	1	123542	FLANGE 2" 125# 2" NPT	24	1	9-291	UNION, 1" NPT 300# BI
7	1	64048	ACTUATOR, SSOV W/ REGULATOR	25	1	124142	VALVE, SSOV, DOUBLE BODY, 2" NPT
8	2	12951-2	BUSHING, CONTROL BOX	26	1	27086-1	ACTUATOR, SSOV W/O P.O.C. SWITCH
9	4	92077	1/4" NPT MXF BRASS BALL VALVE	27	2	95029	FLANGE, SSOV 1 1/2" NPT
10	3	9-22	PIPE PLUG, 1/4" NPT, STEEL	33	1	124094	UNION, 3/4" NPT #150
11	1	99017	SNUBBER, PRESSURE, 1/4"	41	1	122774	VALVE, VENT 3/4" NPT
19	1	93382	2" NPT CAP	44	2	60020	GAS PRESSURE SWITCH, 2-20" W.C.
20	1	92006-7	VALVE, BALL BRASS 1-1/2" NPT	49	1	97087-20	TUBING, FLEXIBLE 20"
21	1	9-294	UNION, 2" NPT 300#				

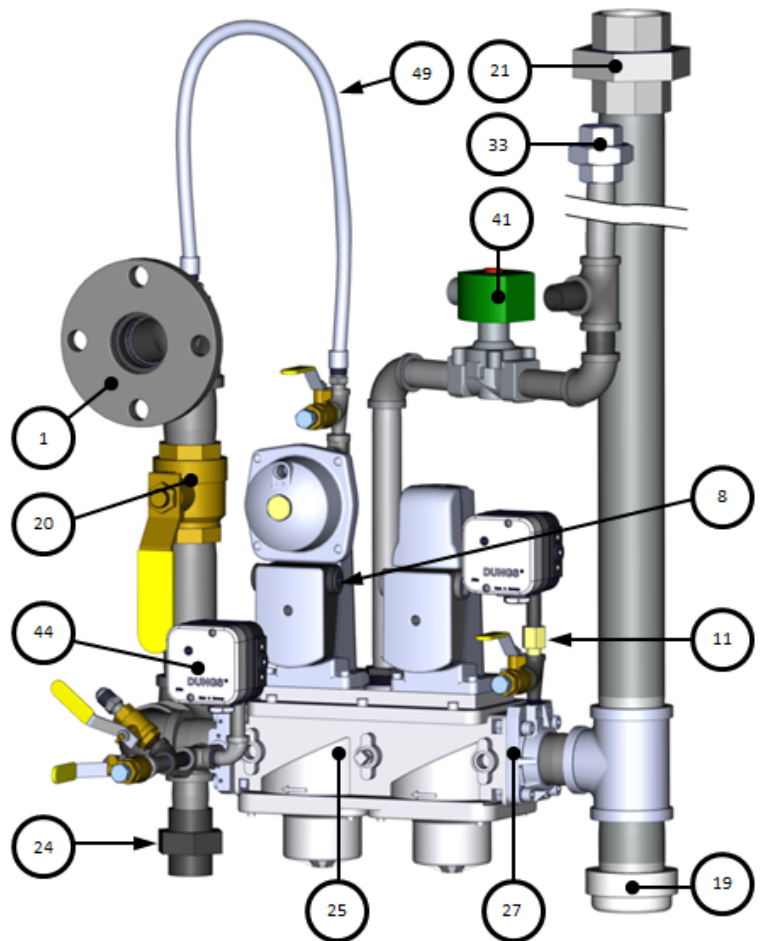
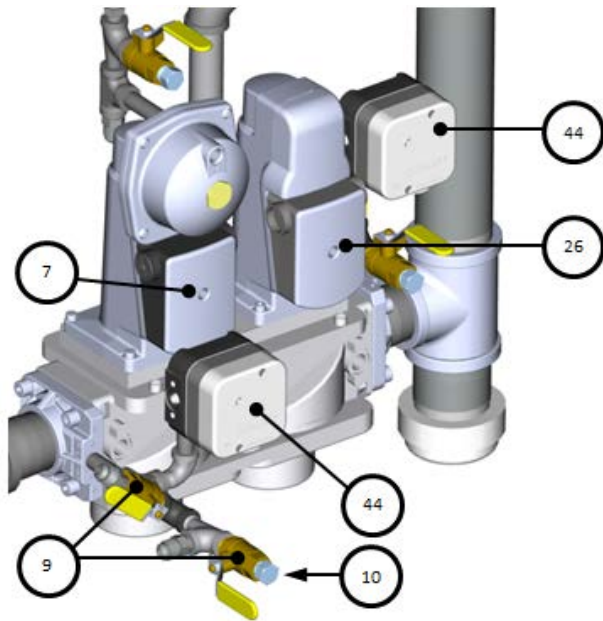

AERCO International, Inc. Blauvelt, NY 10913	Benchmark 1500DF-2000DF DBB NATURAL GAS Gas Train	09/17/2015
	22199-1 rev D, component of 22201	Sheet 1 of 1

Benchmark 1500DF – 2000DF DBB PROPANE Gas Train – P/N 22200							
Item	Qty	Part #	Description	Item	Qty	Part #	Description
1	1	64048	ACTUATOR, SSOV W/ REGULATOR	17	2	92036	VALVE, SSOV 1" NPT1
2	2	12951-2	BUSHING, CONTROL BOX	20	1	27086-1	ACTUATOR, SSOV W/O P.O.C. SWITCH
5	2	9-22	PIPE PLUG, 1/4" NPT, STEEL	27	1	124094	UNION, 3/4" NPT #150
8	2	92077	1/4" NPT MXF BRASS BALL VALVE	28	1	93466	CAP, 1" NPT M/I
14	1	99017	SNUBBER, PRESSURE, 1/4"	29	1	122774	VALVE, VENT 3/4" NPT
16	1	9-291	UNION, 1" NPT 300# BI	31	2	60020	GAS PRESSURE SWITCH, 2-20" W.C.

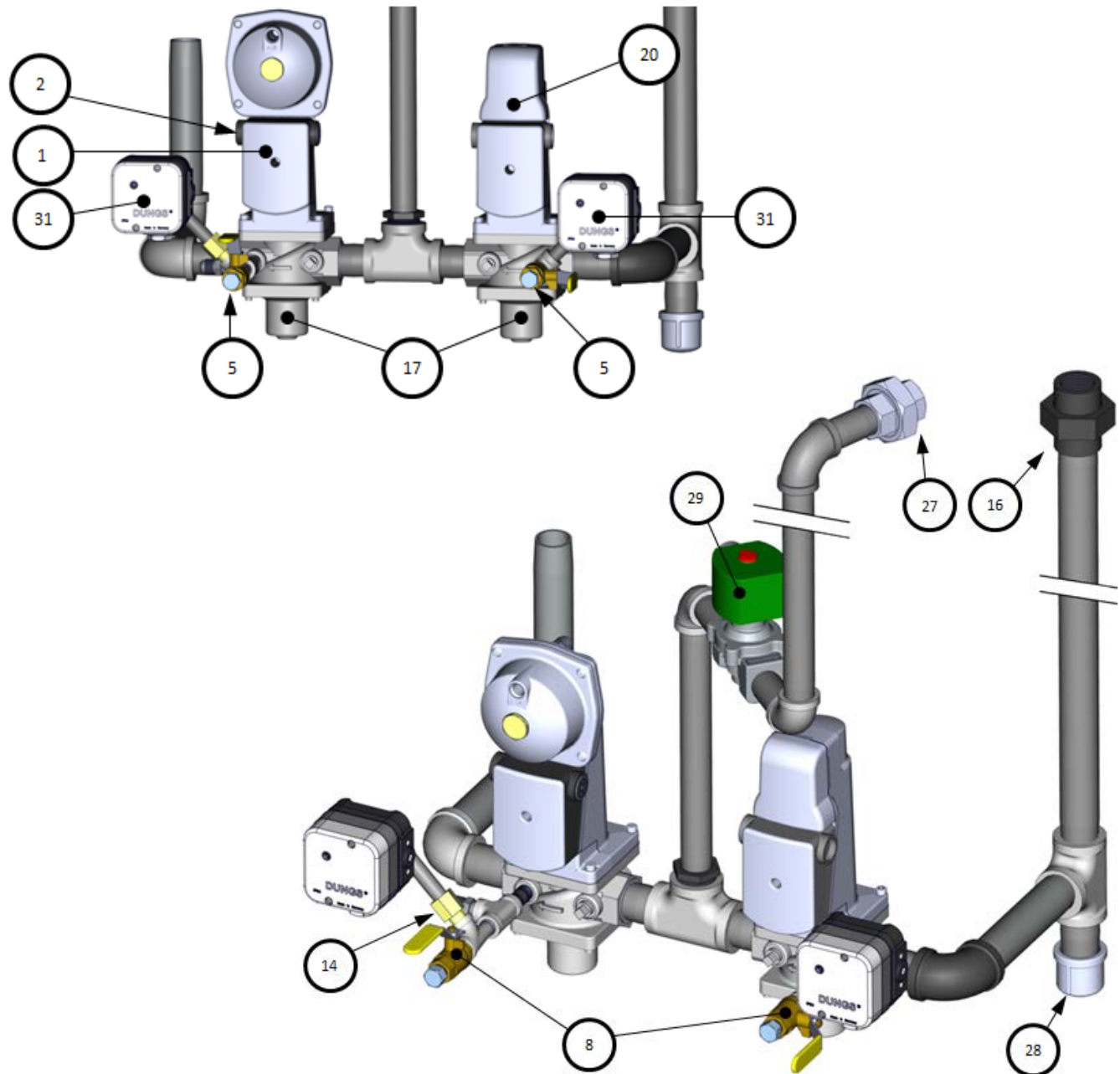

AERCO International, Inc. Blauvelt, NY 10913	Benchmark 1500DF-2000DF DBB PROPANE Gas Train	10/16/2015
	22200 rev E, component of 22201	Sheet 1 of 1

Appendix H: Benchmark PLATINUM 2500/3000 Part Lists

Benchmark 2500/2500 DF & 3000/3000 DF Part List

Item #	Qty	Part #	Description
EXHAUST MANIFOLD			
1	1	39156	MANIFOLD: EXHAUST
2	1	84040	SEAL: MANIFOLD
3	6	9-22	PIPE PLUG: 1/4" NPT: STEEL
GAS TRAIN ASSEMBLY			
4	1	22190	BMK 2500 FM GAS TRAIN ASSY
		22211	BMK 2500 GAS TRAIN: DBB
		22210	BMK 2500 GAS TRAIN: Dual Fuel
		22209	BMK 2500 GAS TRAIN: Dual Fuel DBB
		22171	BMK 3000 FM GAS TRAIN
		22173	BMK 3000 GAS TRAIN: DBB
		22174	BMK 3000 GAS TRAIN: Dual Fuel
22183	BMK 3000 GAS TRAIN: Dual Fuel DBB		
BURNER, AIR/FUEL VALVE AND HEAT EXCHANGER			
8	1	26015-TAB	BMK 2500 BURNER ASSY
		26014-TAB	BMK 3000 BURNER ASSY
10	1	46039	BMK 2500 BURNER
		46038	BMK 3000 BURNER
11	1	24277	STAGED IGNITION ASSY.
14	1	43090	AIR/FUEL VALVE PLENUM
15	1	24311-1	AIR/FUEL VALVE, BMK 3000 Replacement Kit
		24311-7	AIR/FUEL VALVE, BMK 3000 DF Replacement Kit
		24311-8	AIR/FUEL VALVE, BMK 2500 Replacement Kit
		24311-9	AIR/FUEL VALVE, BMK 2500 DF Replacement Kit
HOSES & INSULATION			
16	1	97087-72	FLEX TUBE 72" LONG (1.83 m)
17	1	80081	SHELL INSULATION
BLOWER			
18	1	58063-1 ^❶	BLOWER 460V Replacement Kit
		58063-2	BLOWER 208V Replacement Kit
21	1	24356-1	FLAME DETECTOR Replacement Kit
22	1	61026	LEAN OXYGEN SENSOR
24	1	58023	IGNITOR-INJECTOR Replacement Kit
25	1	88014	AIR FILTER
26	1	43091	BLOWER PLENUM
27	1	123966	ADJUSTABLE TEMP LIMIT SWITCH
28	1	123552	OVER TEMP-MANUAL RESET SWITCH
29	1	60011-2	BMK 3000 BLOWER PROOF SWITCH
		60011-5	BMK 2500 BLOWER PROOF SWITCH
30	1	61002-5	BLOCKED INLET SWITCH -4.5" W.C.
31	1	69186-4	C-MORE CONTROLLER
32	1	65085	IGNITION TRANSFORMER
34	1	93230	SNUBBER - AIR/FUEL VALVE

35	1	64081	ECU, O ₂ SENSOR
36	1	65011	TRANSFORMER 115V/24V 100VA
37	1	65109	12V POWER SUPPLY
38	3	69141	DIN RAIL MOUNT END STOP
39	2	65120	TERMINAL BLOCK: DIN MOUNTED: BLK
40	2	65121	TERMINAL BLOCK: DIN MOUNTED: WHT
41	3	65122	TERMINAL GROUND BLOCK: DIN MOUNTED
42	2	65118	FUSE TERMINAL: DIN MOUNTED
43	1	64088	LIMIT CONTROL TEMPERATURE, DIGITAL CONTROLLER
44	1	65128	3 POLE 20A BREAKER
46	1	65162	24V POWER SUPPLY (Sequencing Valve)
47 ^❶	2	124512	FUSE: 4 AMP
48	2	123449	SENSOR: TEMPERATURE
49	1	58132	THERMOWELL Replacement Kit
51	1	63035-1	FUEL SELECTOR SWITCH & HARNESS Dual Fuel Only
52	1	69227	ONAEER COMMUNICATION BOARD
53	1	124310 ^❷	TRANSFORMER – 460V ONLY
54	1	33170	MOUNTING PANEL
55	1	124324	GROUND BAR
60	1	69102-3	PUMP RELAY
61	1	61030	SENSOR: OUTLET TEMPERATURE
62	1	69172	INPUT/OUTPUT (PCB) ASSY
63	1	67009	DIAL THERMOMETER
67 ^❶	1	61034	SPARK MONITOR (Current Transducer)
68	1	65147	EBM 12VDC AXIAL VENT FAN Dual Fuel Only
SHEET METAL/PANEL ASSEMBLY			
69 ^❶	1	38035	I/O PANEL COVER
70 ^❶	1	38036	POWER PANEL COVER
72	1	37148	BACK PANEL RIGHT (Black)
73	1	37149	BACK PANEL: LEFT (Black)
74	2	35046	TOP RAIL (Black)
75	1	25087	FRONT FRAME ASSEMBLY (Black)
76	1	25086	FRONT PANEL (Platinum)
79	4	59133	LATCH, COMPRESSION
80	1	30156	TOP PANEL, FRONT (Black)
81	1	30157	TOP PANEL, BACK (Black)
82	2	30155	SIDE PANEL (Black)
84	1	39215	AIR INLET ADAPTER, 8" (Black)
85	2	38044	AIR INLET COVER PANEL (Black)
OTHER ACCESSORIES & PARTS			
90	1	69126	LOW WATER CUTOFF CAPACITOR FRU Kit
91	1	123863	1/8" NTP BALL VALVE
92	1	92094	3/4" DRAIN VALVE
95	1	59178	1/8" AIR VENT

^❶ Not shown on drawing

^❷ Only used in 460 v units

AERCO International, Inc. Blauvelt, NY 10913	Benchmark 2500/2500DF & 3000/3000DF Part List	10/09/2017
	Benchmark 2500 28536-TAB rev E Benchmark 3000 28382-TAB rev F	Sheet 1 of 9

Benchmark 2500/3000 Spare Parts Kit P/N 58048-TAB					
Kit Number *	Description	Pressure Relief Valve Kit	Pressure/Temp Gauge	Condensate Trap Assy.	2" Ball Valve
58048-C30	30 PSI (207 kPa) KIT (CONBRACO)	92016-1	123675-5	24441	123540
58048-C50	50 PSI (345 kPa) KIT (CONBRACO)	92016-2	123675-5		
58048-C60	60 PSI (414 kPa) KIT (CONBRACO)	92016-3	123675-6		
58048-C75	75 PSI (517 kPa) KIT (CONBRACO)	92016-4	123675-6		
58048-C100	100 PSI (689 kPa) KIT (CONBRACO)	92016-5	123675-6		
58048-C125	125 PSI (862 kPa) KIT (CONBRACO)	92016-6	123675-6		
58048-C150	150 PSI (1034 kPa) KIT (CONBRACO)	92016-7	123675-7		
58048-W50	50 PSI (345 kPa) KIT (WATTS)	92016-8	123675-5		
58048-W60	60 PSI (414 kPa) KIT (WATTS)	92016-9	123675-6		
58048-W75	75 PSI (517 kPa) KIT (WATTS)	92016-10	123675-6		
58048-W100	100 PSI (689 kPa) KIT (WATTS)	92016-11	123675-6		
58048-W125	125 PSI (862 kPa) KIT (WATTS)	92016-12	123675-6		
58048-W150	150 PSI (1034 kPa) KIT (WATTS)	92016-13	123675-7		
58048-K160	160 PSI (1103 kPa) KIT (KUNKLE)	92016-14	123675-7		

* For Dual Fuel units add "DF" to the part number (i.e., 58048-C30-DF)

Wiring Harnesses (not shown in figures below)	
Part #	Description
63004	HARNESS: 460V TRANSFORMER – 460 V only
63059	HARNESS: DRIVE REACTOR BMK 3.0
63083	HARNESS: O2 SENSOR
63090	HARNESS: TEMP LIM CONTROL
63103	HARNESS: SHELL
63104	HARNESS: I/O INTERLOCK
63105	HARNESS: I/O SENSOR/COMM
63109	HARNESS: GAS TRAIN
63111	HARNESS: CONTROL
63134	VENT FAN POWER WIRE – DUAL FUEL ONLY
65104	CABLE, H.V. IGNITION

Benchmark 2500/3000 Kits Available	
Part #	Description
27086-2	ACTUATOR: SSOV w/o P.O.C. SWITCH Replacement Kit
64048	SSOV WITH PRESSURE REGULATOR Replacement Kit

Other Accessories / Parts (Optional)	
Part #	Description
92084-6	MOTORIZED SEQUENCING VALVE

AERCO International, Inc. Blauvelt, NY 10913	Benchmark 2500/2500DF & 3000/3000DF Part List	10/09/2017
	Benchmark 2500 28536-TAB rev E Benchmark 3000 28382-TAB rev F	Sheet 2 of 9

APPENDIX H – BENCHMARK 2500/3000 PART LISTS

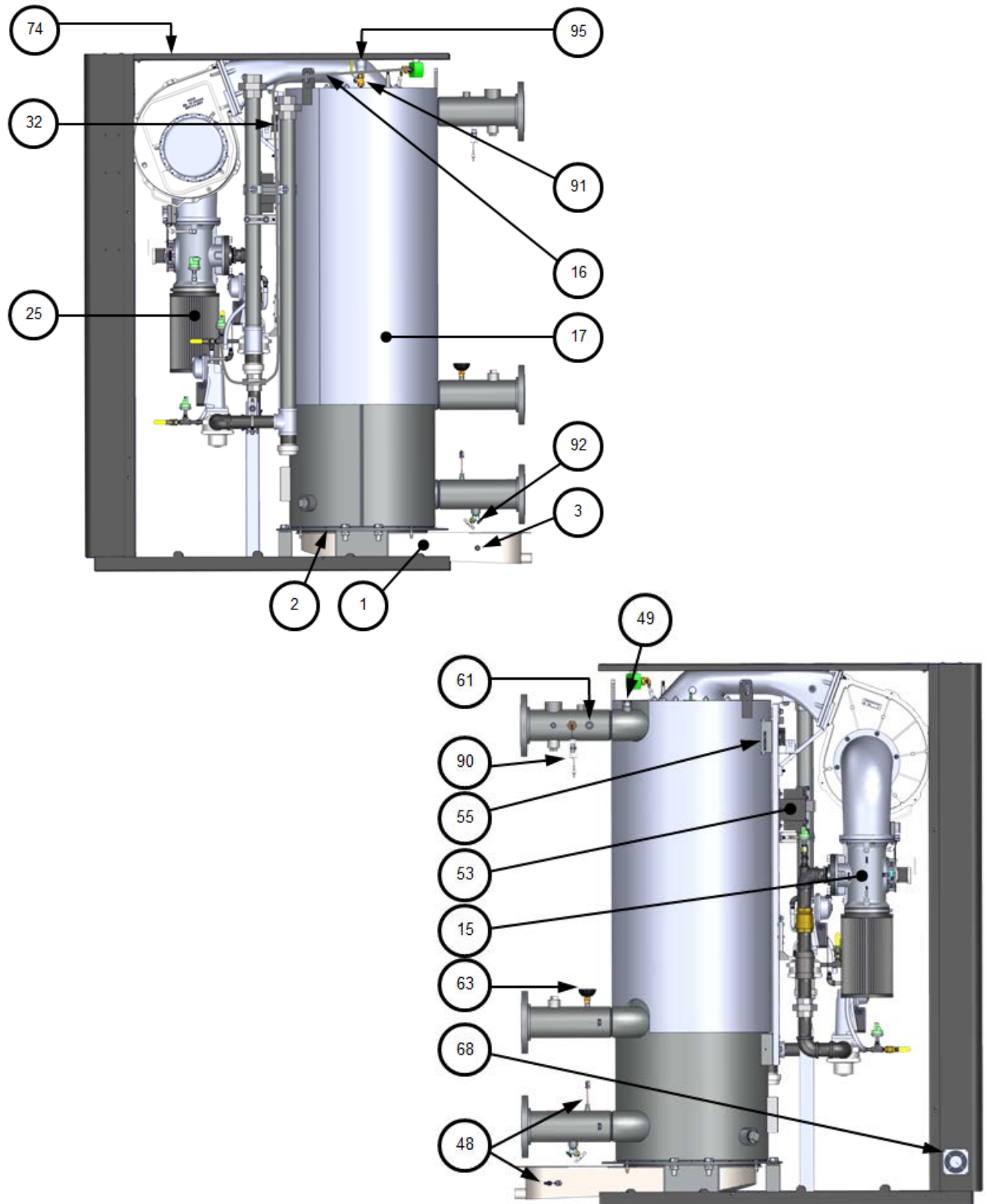

AERCO International, Inc. Blauvelt, NY 10913	Benchmark 2500/2500DF & 3000/3000DF Part List	10/09/2017
	Benchmark 2500 28536-TAB rev E Benchmark 3000 28382-TAB rev F	Sheet 3 of 9

APPENDIX H – BENCHMARK 2500/3000 PART LISTS

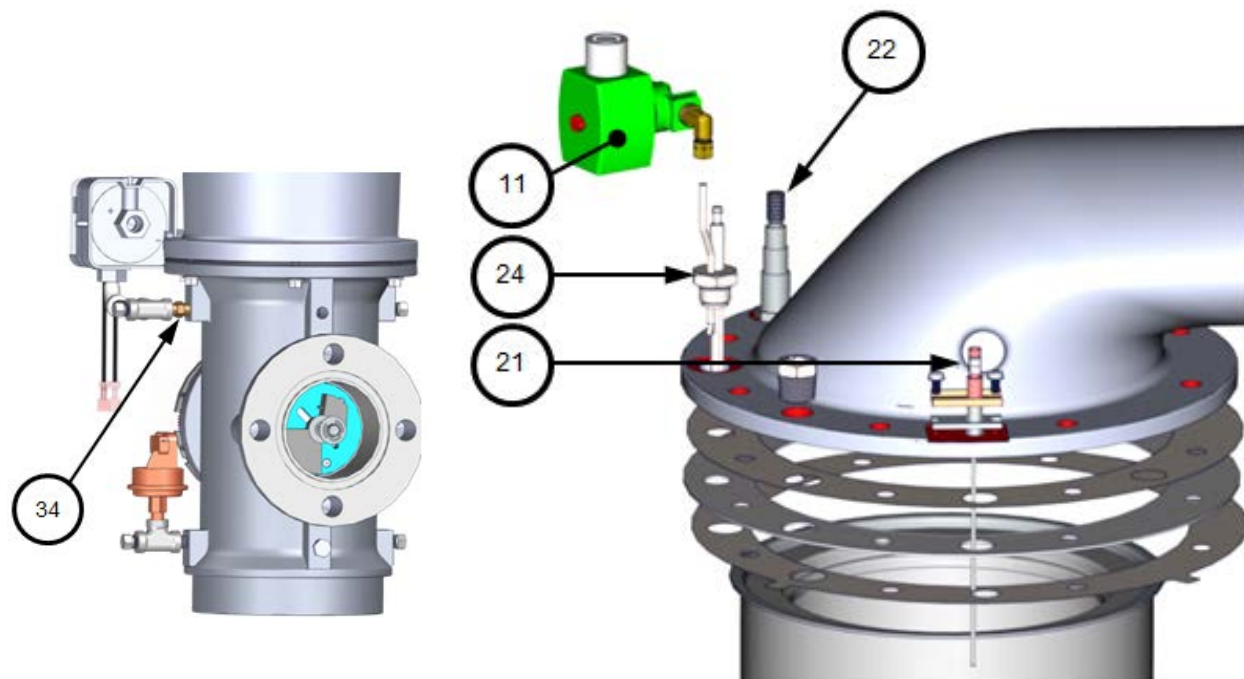
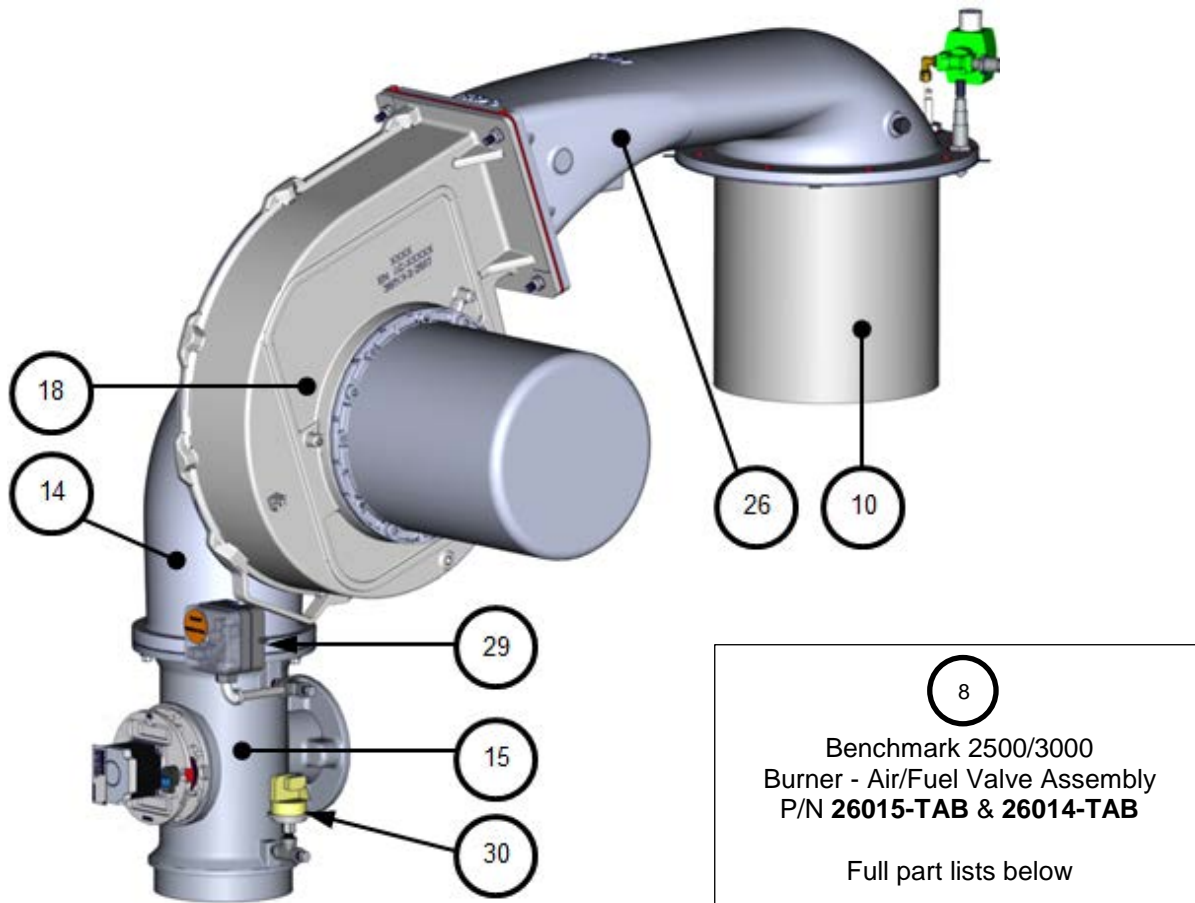

AERCO International, Inc. Blauvelt, NY 10913	Benchmark 2500/2500DF & 3000/3000DF Part List	10/09/2017
	Benchmark 2500 28536-TAB rev E Benchmark 3000 28382-TAB rev F	Sheet 4 of 9

APPENDIX H – BENCHMARK 2500/3000 PART LISTS

4

Benchmark 3000
 Standard FM Gas Train
 P/N 22171
 See full drawing below

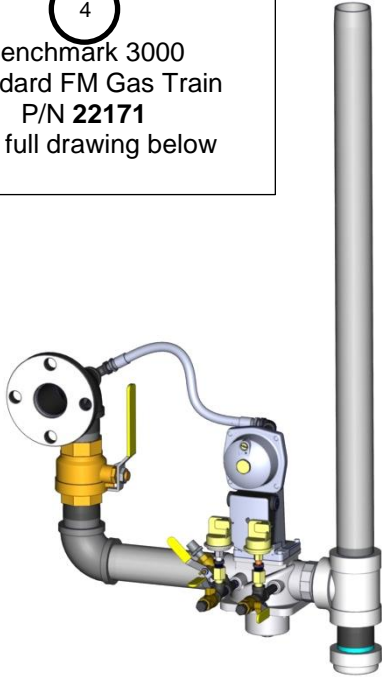

4

Benchmark 3000
 Double Block & Bleed Gas Train
 P/N 22173
 See full drawing below

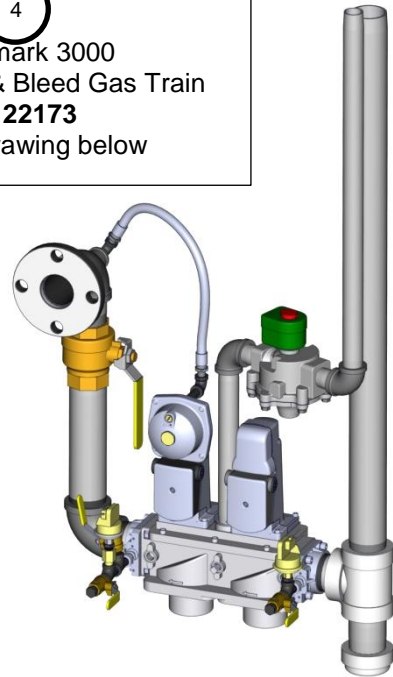

4

Benchmark 2500
 Standard FM Gas Train
 P/N 22190
 See full drawing below

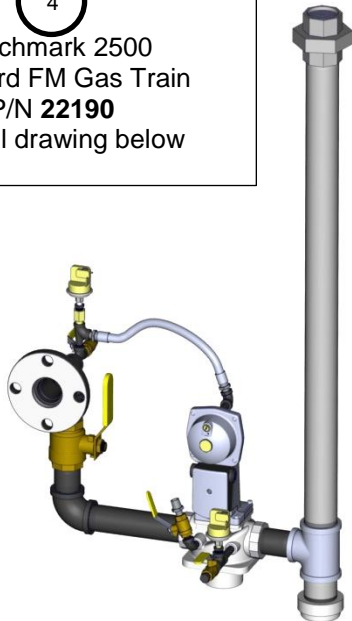

4

Benchmark 2500
 Double Block & Bleed Gas Train
 P/N 22211
 See full drawing below

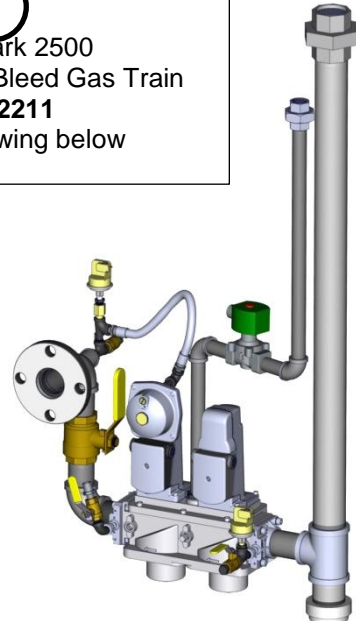

AERCO International, Inc. Blauvelt, NY 10913	Benchmark 2500/2500DF & 3000/3000DF Part List	10/09/2017
	Benchmark 2500 28536-TAB rev E Benchmark 3000 28382-TAB rev F	Sheet 5 of 9

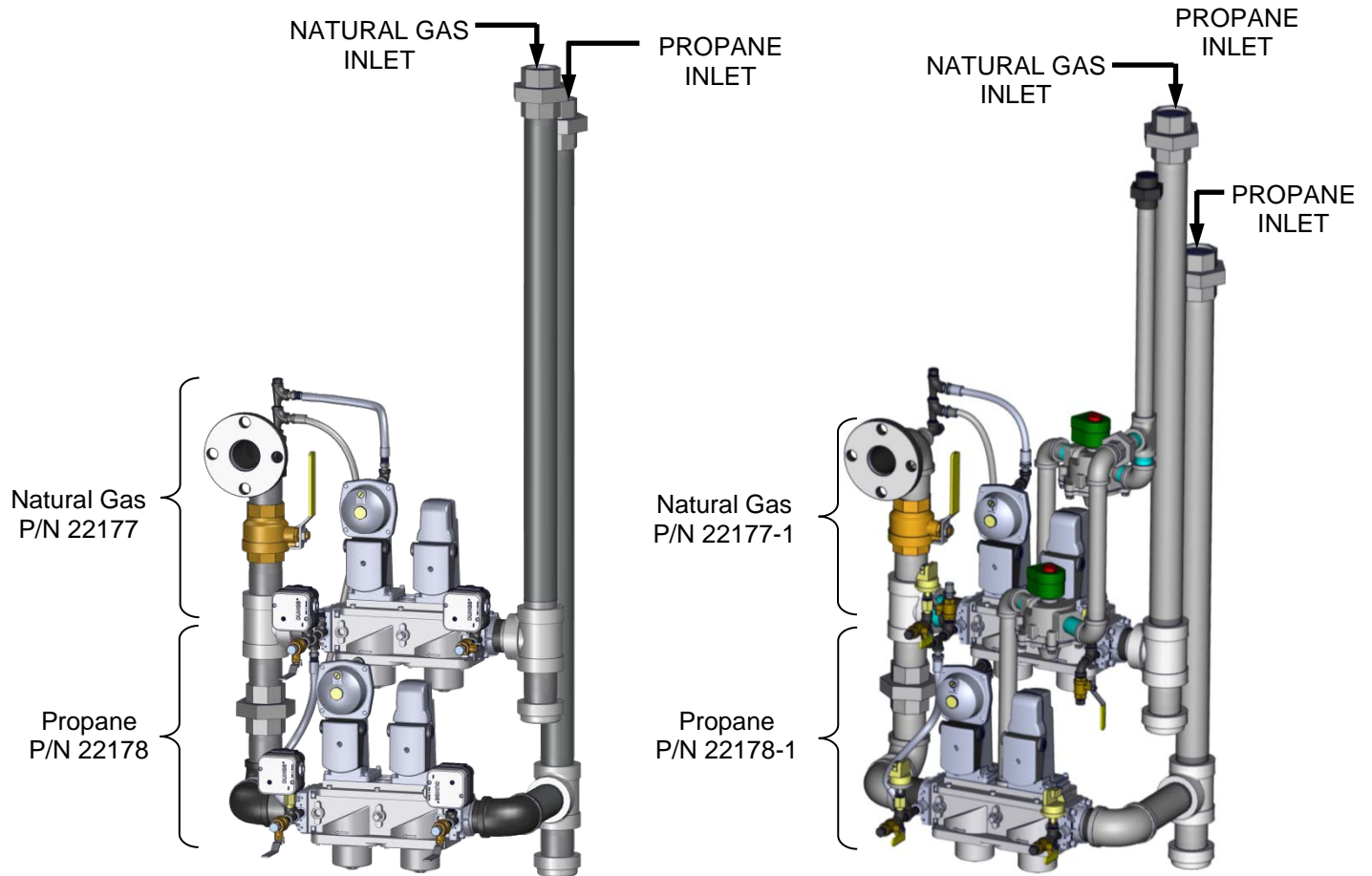

4

Benchmark 3000 Dual Fuel
 FM Gas Train
 P/N 22174

See full diagram below

4

Benchmark 3000 Dual Fuel
 Double Block & Bleed Gas Train
 P/N 22183

See full diagram below

AERCO International, Inc. Blauvelt, NY 10913	Benchmark 2500/2500DF & 3000/3000DF Part List	10/09/2017
	Benchmark 2500 28536-TAB rev E Benchmark 3000 28382-TAB rev F	Sheet 6 of 9

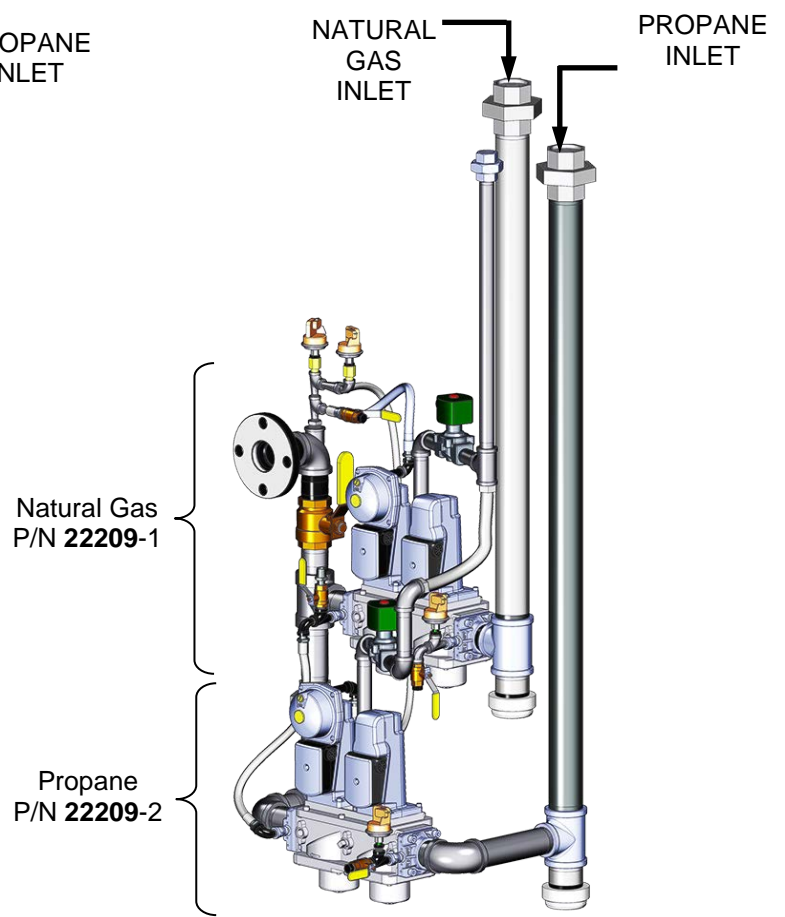
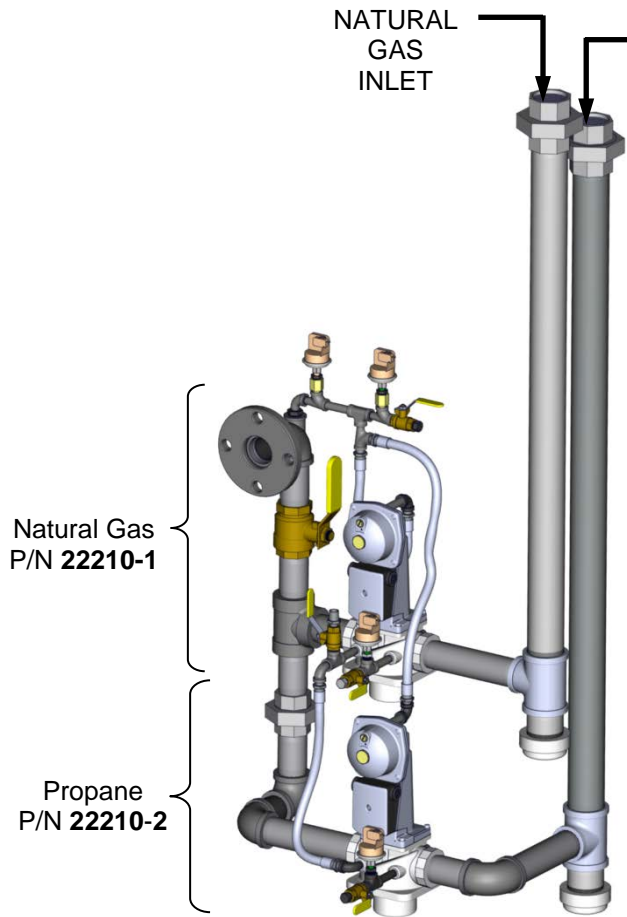

4

Benchmark 2500 Dual Fuel
 FM Gas Train
 P/N 22210

See full diagram below

4

Benchmark 2500 Dual Fuel
 Double Block & Bleed Gas Train
 P/N 22209

See full diagram below

AERCO International, Inc. Blauvelt, NY 10913	Benchmark 2500/2500DF & 3000/3000DF Part List	10/09/2017
	Benchmark 2500 28536-TAB rev E Benchmark 3000 28382-TAB rev F	Sheet 7 of 9

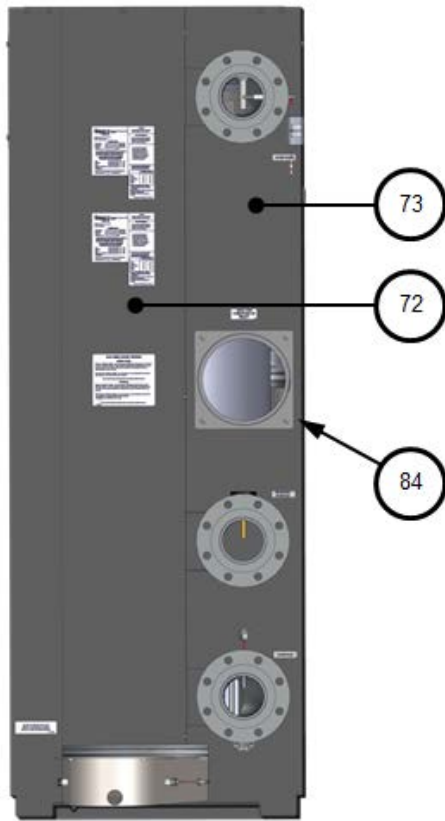

REAR VIEW

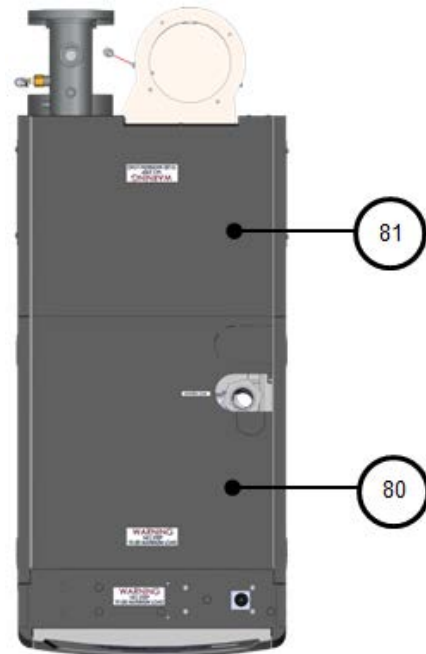

TOP VIEW

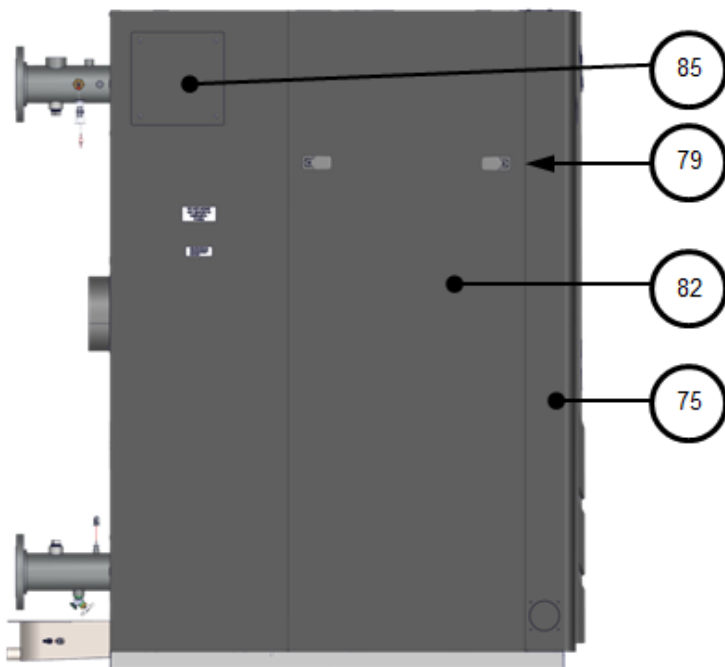

LEFT SIDE VIEW

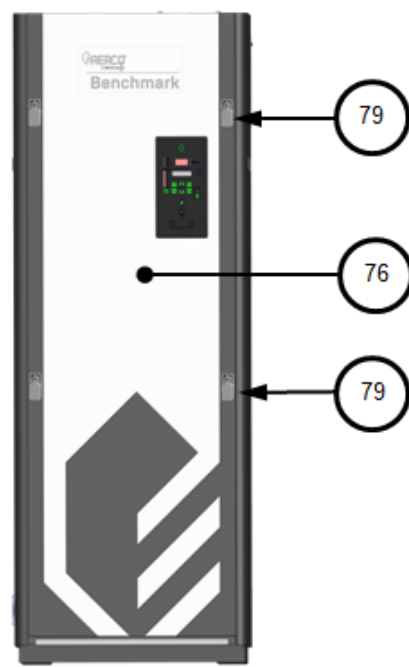

FRONT VIEW

AERCO International, Inc. Blauvelt, NY 10913	Benchmark 2500/2500DF & 3000/3000DF Part List	10/09/2017
	Benchmark 2500 28536-TAB rev E Benchmark 3000 28382-TAB rev F	Sheet 8 of 9

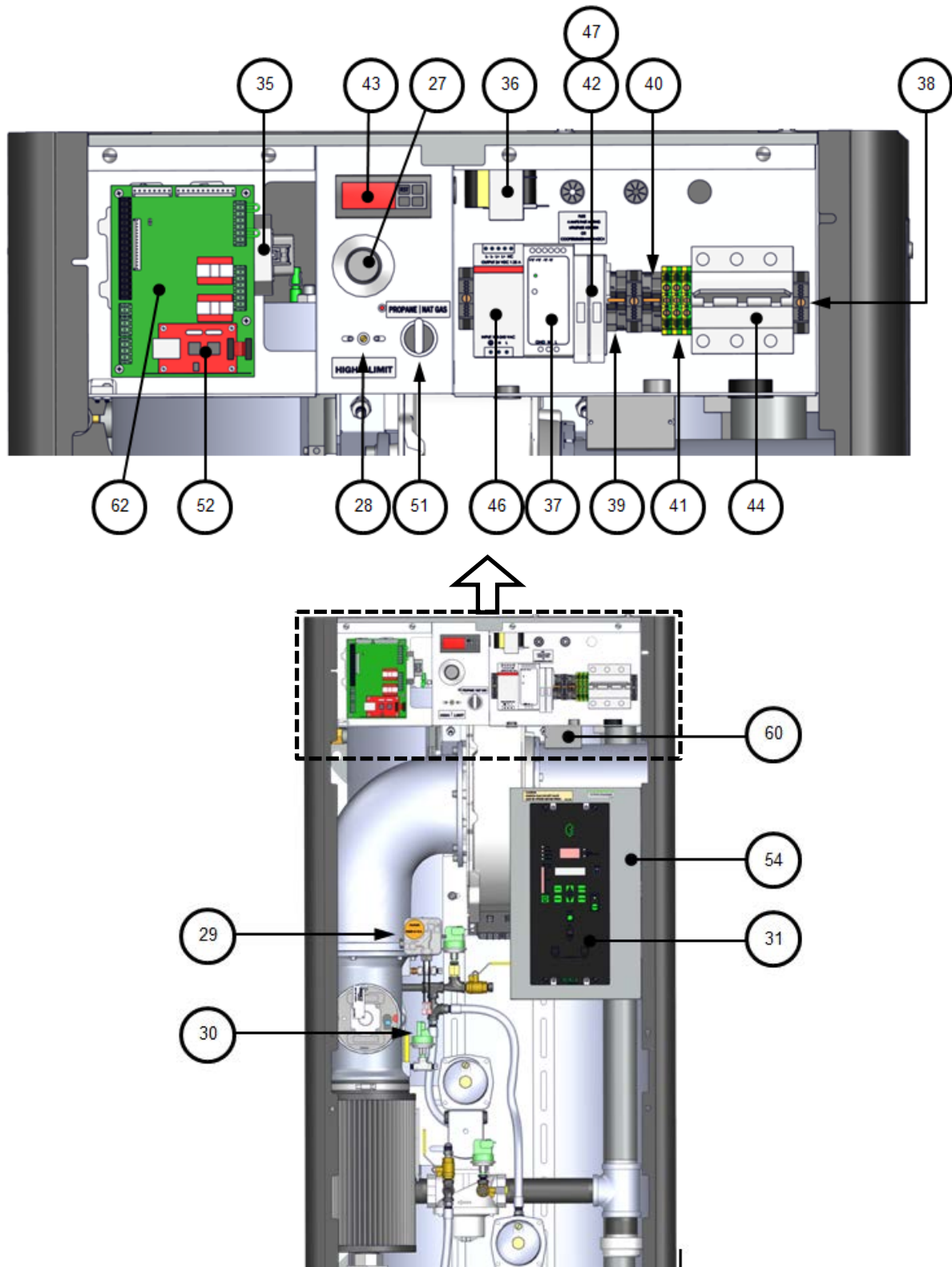

PARTIAL FRONT VIEW – FRONT PANEL REMOVED

AERCO International, Inc. Blauvelt, NY 10913	Benchmark 2500/2500DF & 3000/3000DF Part List	10/09/2017
	Benchmark 2500 28536-TAB rev E Benchmark 3000 28382-TAB rev F	Sheet 9 of 9

Benchmark 3000 FM Gas Train – P/N 22171

Item	Qty.	P/N	Description	Item	Qty.	P/N	Description
1	1	123542	FLANGE 2" 125# 2" NPT	26	1	60020	SWITCH: GAS PRESSURE 2-20" W.C.
5	1	123540	VALVE: BALL 2" FULL PORT	27	2	9-22	PIPE PLUG: 1/4" NPT: STEEL
7	1	99015	DAMPING ORIFICE: SSOV	29	1	99017	SNUBBER: PRESSURE: 1/4"
9	1	64048	ACTUATOR: SSOV W/ REGULATOR	31	1	60032-1	SWITCH: GAS PRESSURE 1-20" W.C.
10	2	12951-2	BUSHING: CONTROL BOX	32	2	92143	1/4" BALL VALVE: WATTS
12	1	124136	VALVE: SSOV 2" NPT	33	1	9-294	UNION: 2" NPT 300#
18	1	97087-12	FLEX GAS TUBING 12"				

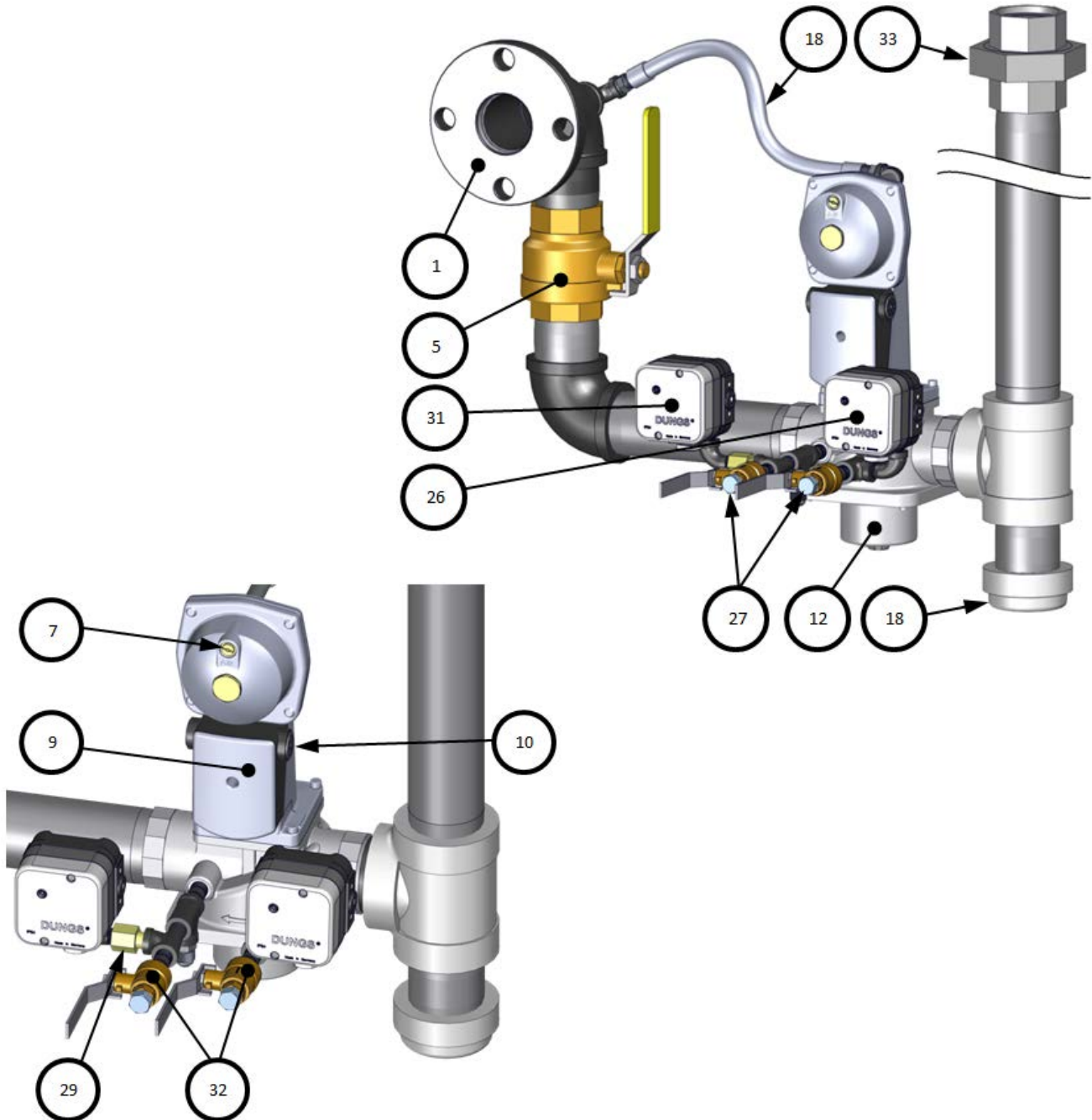

AERCO International, Inc. Blauvelt, NY 10913	Benchmark 3000 FM Gas Train	01/17/2017
	P/N 22171 rev J	Sheet 1 of 1

Benchmark 3000 DBB Gas Train – NATURAL GAS – P/N 22173

Item	Qty	Part #	Description	Item	Qty	Part #	Description
1	1	123542	FLANGE 2" 125# 2"NPT	23	1	93382	2" NPT CAP
4	1	123540	VALVE: BALL 2" FULL PORT	27	1	99017	SNUBBER: PRESSURE: 1/4"
6	2	95030	FLANGE: SSOV 2" NPT	28	2	9-22	PIPE PLUG: 1/4" NPT: STEEL
7	1	124142	VALVE: SSOV: DOUBLE BODY: 2" NPT	31	1	97087-16	TUBING: FLEXIBLE GAS 12"
11	1	64048	ACTUATOR: SSOV W/ REGULATOR	35	2	92143	1/4" BALL VALVE: WATTS
12	1	27086-1	ACTUATOR: SSOV W/O P.O.C. SWITCH	36	1	9-294	UNION: 2" NPT 300#
13	1	99015	DAMPING ORIFICE: SSOV	37	1	60020	SWITCH: GAS PRESSURE 2-20" W.C.
15	1	123769	VALVE: SOLENOID N.O. 1" NPT	38	1	124094	UNION: 3/4" NPT #150
18	4	12951-2	BUSHING: CONTROL BOX	39	1	60032-1	SWITCH: GAS PRESSURE 1-20" W.C.

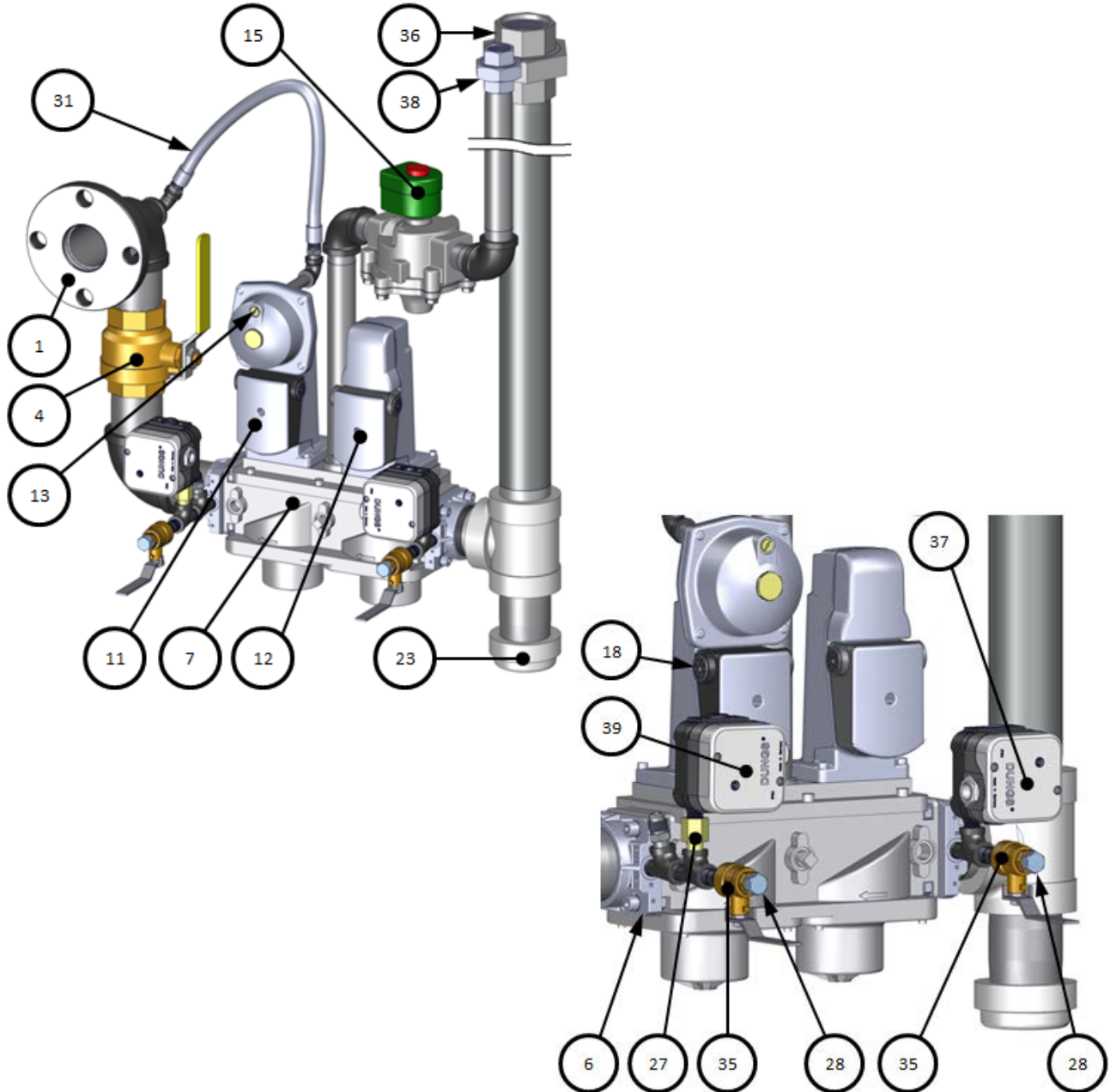

AERCO International, Inc. Blauvelt, NY 10913	Benchmark 3000 DBB Gas Train – Natural Gas	01/04/2017
	22173 rev K	Sheet 1 of 2

Benchmark 2500 FM Gas Train – P/N 22190

Item	Qty	Part #	Description	Item	Qty	Part #	Description
1	1	123542	FLANGE 2" 125# 2"NPT	25	3	92077	1/4" NPT MXF BRASS BALL VALVE
7	1	92006-7	VALVE: BALL BRASS 1-1/2" NPT	26	2	9-22	PIPE PLUG: 1/4" NPT: STEEL
10	1	124150	VALVE: SSOV 1-1/2" NPT	28	2	12951-2	BUSHING: CONTROL BOX
11	1	64048	ACTUATOR: SSOV W/ REGULATOR	29	1	99017	SNUBBER: PRESSURE: 1/4"
15	1	93382	2" NPT CAP	32	1	99015	DAMPING ORIFICE: SSOV
19	1	97087-12	Flex Tubing 12"	33	1	9-294	UNION: 2" NPT 300#
24	1	61002-11	LOW GAS PRESSURE SWITCH 3.6" W.C.	34	1	61002-22	HIGH GAS PRESSURE SWITCH 3.0" W.C.

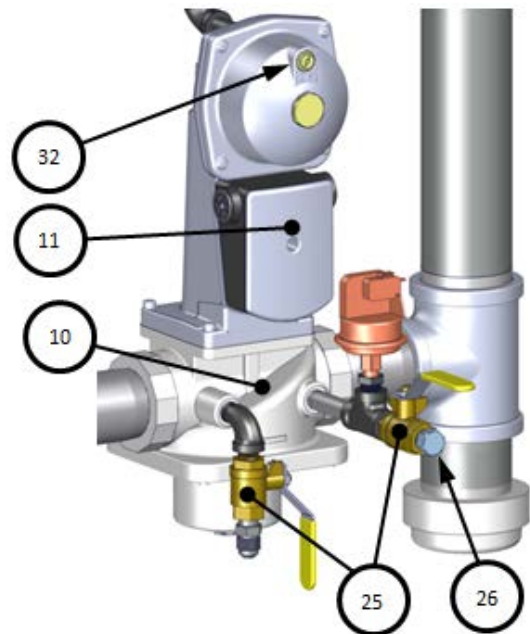
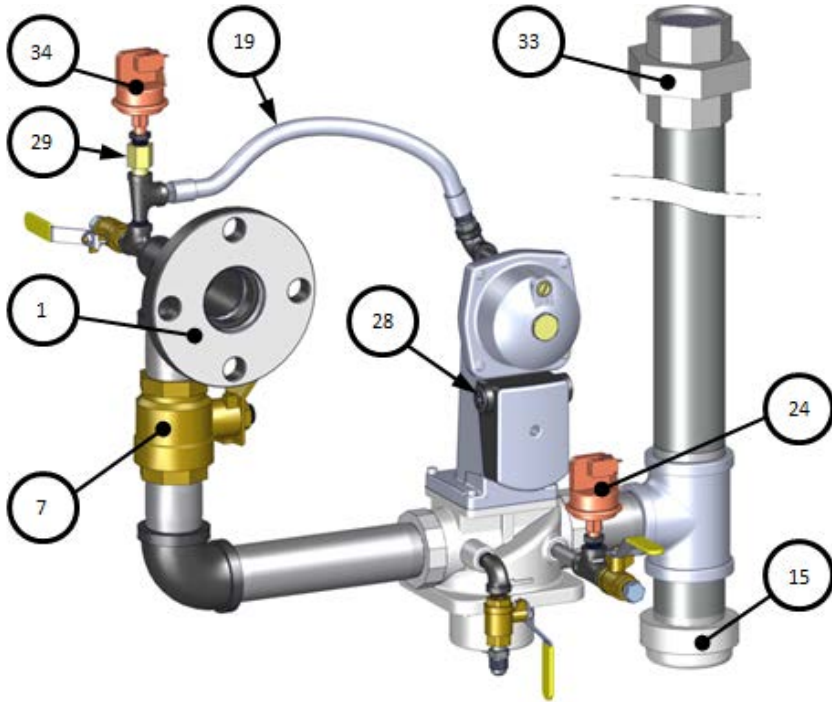

AERCO International, Inc. Blauvelt, NY 10913	Benchmark 2500 FM Gas Train	07/21/2016
	22190 – rev D	Page 1 of 1

Benchmark 2500 Natural Gas DBB Gas Train – P/N 22211							
Item	Qty	Part #	Description	Item	Qty	Part #	Description
1	1	123542	FLANGE 2" 125# 2"NPT	29	1	99015	DAMPING ORIFICE: SSOV
7	1	92006-7	VALVE: BALL BRASS 1-1/2" NPT	30	1	124137	VALVE: SSOV: DOUBLE BODY: 1-1/2" NPT
9	1	64048 *	ACTUATOR: SSOV W/ REGULATOR	31	2	95029	FLANGE: SSOV 1 1/2" NPT
13	1	93382	2" NPT CAP	32	1	27086-1 *	ACTUATOR: SSOV w/o P.O.C. SWITCH
17	1	97087-12	Flex Gas Tubing 12"	33	1	122774	VALVE: VENT 3/4" NPT
21	1	61002-11	LOW GAS PRESSURE SWITCH 3.6" W.C.	40	1	124094	UNION: 3/4" NPT #150
22	3	92077	1/4" NPT MXF BRASS BALL VALVE	41	1	9-294	UNION: 2" NPT 300#
23	4	9-22	PIPE PLUG: 1/4" NPT: STEEL	42	1	61002-22	HIGH GAS PRESSURE SWITCH: 3.0" W.C.
25	4	12951-2	BUSHING: CONTROL BOX	43	1	92143	1/4" BALL VALVE
26	1	99017	SNUBBER: PRESSURE: 1/4"				

* Part number for replacement kit

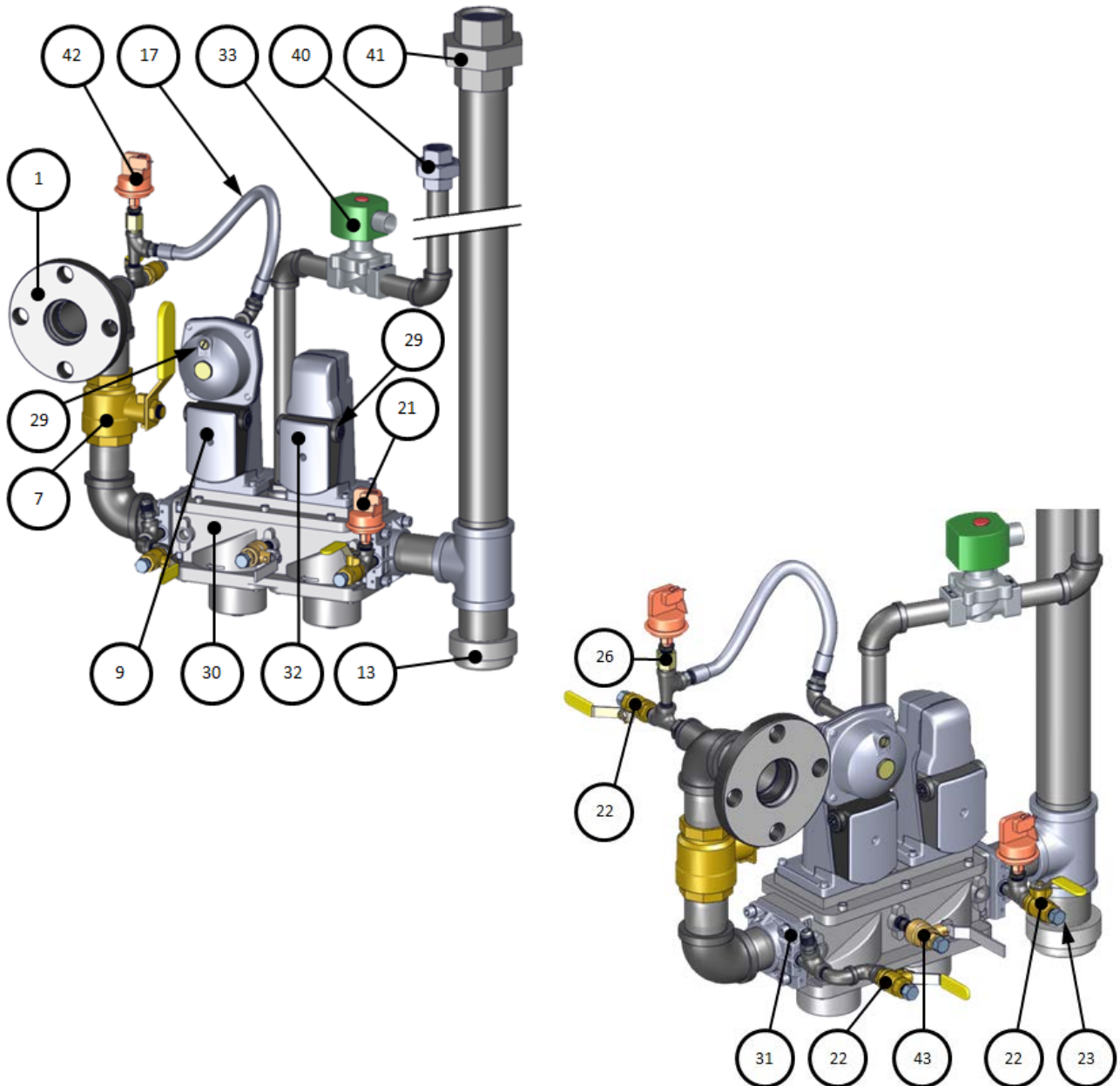

AERCO International, Inc. Blauvelt, NY 10913	Benchmark 2500 Natural Gas DBB Gas Train	06/12/2018
	22211 rev G	Sheet 1 of 1

Benchmark 3000 DF Gas Train – NATURAL GAS – P/N 22177							
Item	Qty	Part #	Description	Item	Qty	Part #	Description
1	1	124142	VALVE: SSOV: DOUBLE BODY: 2" NPT	16	1	99015	DAMPING ORIFICE: SSOV
6	1	123542	FLANGE 2" 125# 2"NPT	20	1	123540	VALVE: BALL 2" FULL PORT
7	1	64048	ACTUATOR: SSOV W/ REGULATOR	21	1	9-294	UNION: 2" NPT 300#
8	4	12951-2	BUSHING: CONTROL BOX	22	2	95030	FLANGE: SSOV 2" NPT
9	1	99017	SNUBBER: PRESSURE: 1/4"	25	1	60032-1	SWITCH: GAS PRESSURE 1-20" W.C.
11	1	27086-1	ACTUATOR: SSOV W/O P.O.C. SWITCH	26	1	60020	SWITCH: GAS PRESSURE 2-20" W.C.
12	2	9-22	PIPE PLUG: 1/4" NPT: STEEL	27	2	92143	1/4" BALL VALVE: WATTS
14	1	93382	2" NPT CAP				

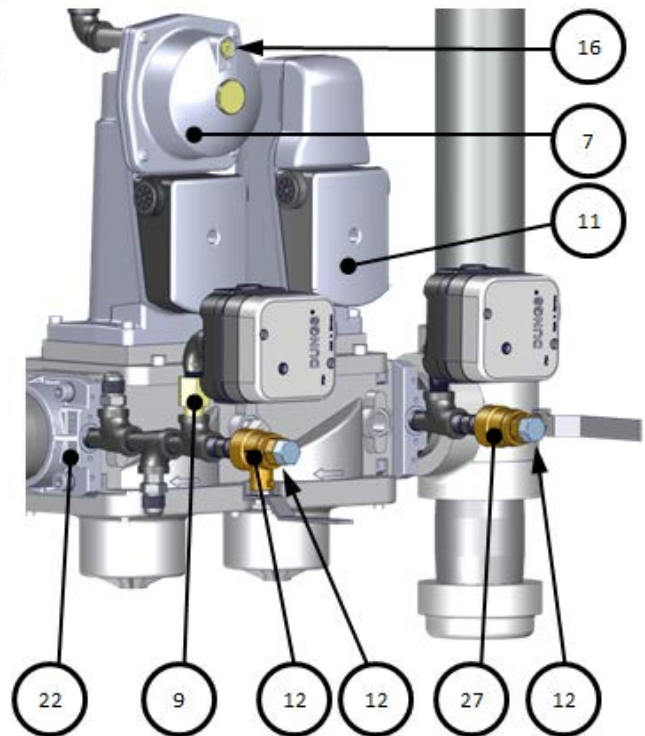
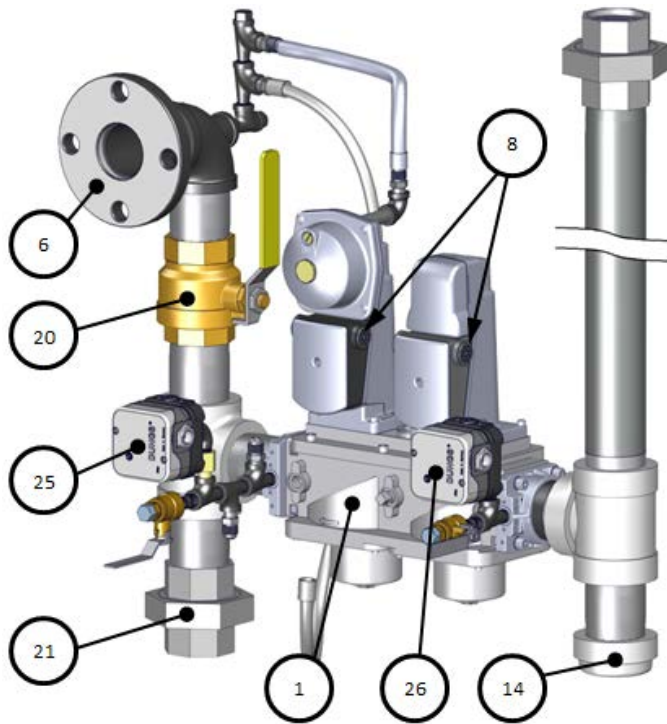

AERCO International, Inc. Blauvelt, NY 10913	Benchmark 3000DF Gas Train – NATURAL GAS	01/03/2017
	22177 rev F, component of 22174	Sheet 1 of 1

Benchmark 3000 DF PROPANE Gas Train – P/N 22178							
Item	Qty	Part #	Description	Item	Qty	Part #	Description
1	1	124142	VALVE: SSOV: DOUBLE BODY: 2" NPT	13	4	12951-2	BUSHING: CONTROL BOX
2	1	64048	ACTUATOR: SSOV W/ REGULATOR	17	2	95030	FLANGE: SSOV 2" NPT
3	1	27086-1	ACTUATOR: SSOV W/O P.O.C. SWITCH	23	1	60032-1	SWITCH: GAS PRESSURE 1-20" W.C.
6	2	9-22	PIPE PLUG: 1/4" NPT: STEEL	24	1	60020	SWITCH: GAS PRESSURE 2-20" W.C.
8	1	99017	SNUBBER: PRESSURE: 1/4"	25	2	92143	1/4" BALL VALVE: WATTS
11	1	93382	2" NPT CAP	*	1	97087-12	FLEX HOSE 12"
12	1	99015	DAMPING ORIFICE: SSOV				

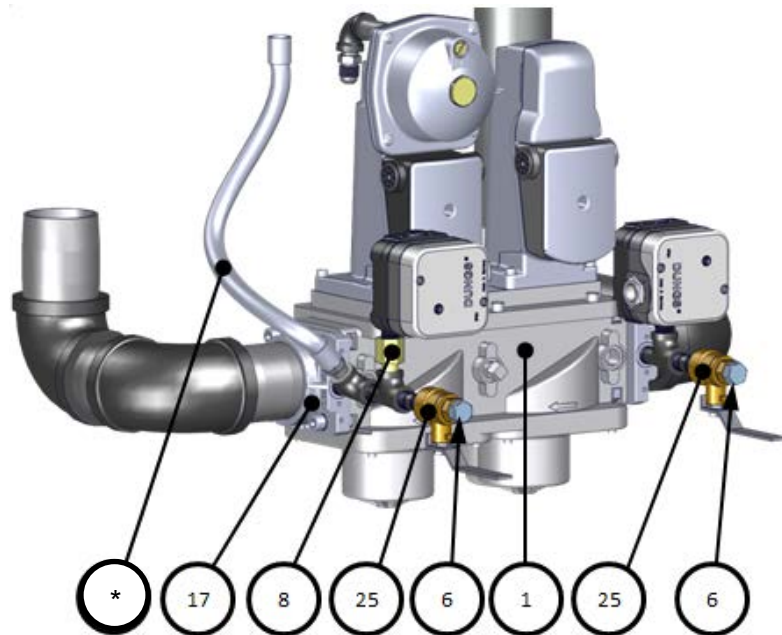
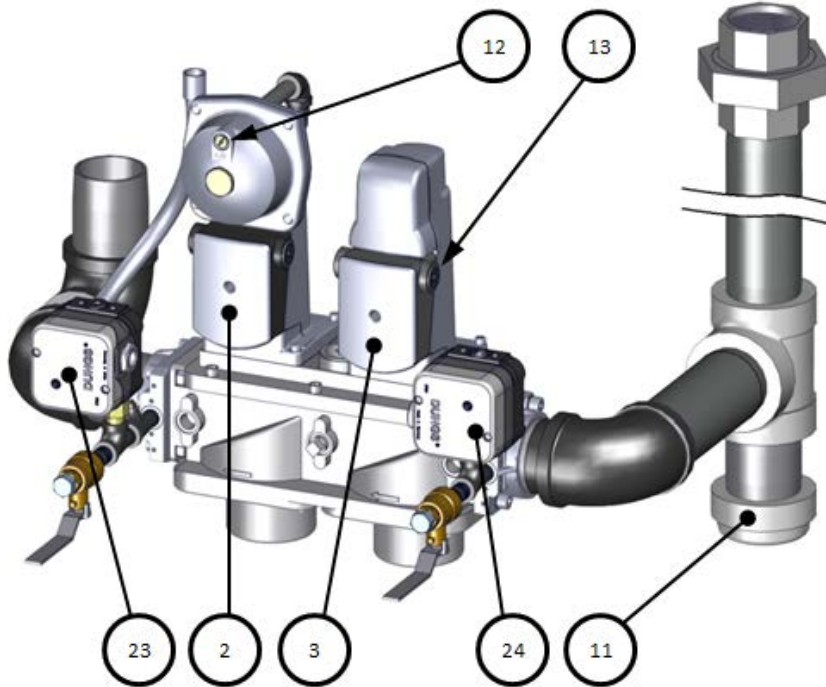

AERCO International, Inc. Blauvelt, NY 10913	Benchmark 3000 DF Gas Train – PROPANE	01/03/2017
	22178 rev F, component of 22174	Sheet 1 of 1

Benchmark 3000 DF DBB NATURAL GAS Gas Train – P/N 22177-1							
Item	Qty	Part #	Description	Item	Qty	Part #	Description
1	1	124142	VALVE: SSOV: DOUBLE BODY: 2" NPT	15	1	99015	DAMPING ORIFICE: SSOV
4	1	123540	VALVE: BALL 2" FULL PORT	19	1	123769	VALVE, SOLENOID N.O. 1" NPT
7	1	123542	FLANGE 2" 125# 2"NPT	23	1	64048	ACTUATOR: SSOV W/ REGULATOR
8	4	12951-2	BUSHING: CONTROL BOX	25	1	9-294	UNION: 2" NPT 300#
9	1	99017	SNUBBER: PRESSURE: 1/4"	29	2	95030	FLANGE: SSOV 2" NPT
11	1	27086-1	ACTUATOR: SSOV W/O P.O.C. SWITCH	32	1	60032-1	SWITCH: GAS PRESSURE 1-20" W.C.
12	2	9-22	PIPE PLUG: 1/4" NPT: STEEL	33	1	60020	SWITCH: GAS PRESSURE 2-20" W.C.
14	1	93382	2" NPT CAP	34	2	92143	1/4" BALL VALVE: WATTS

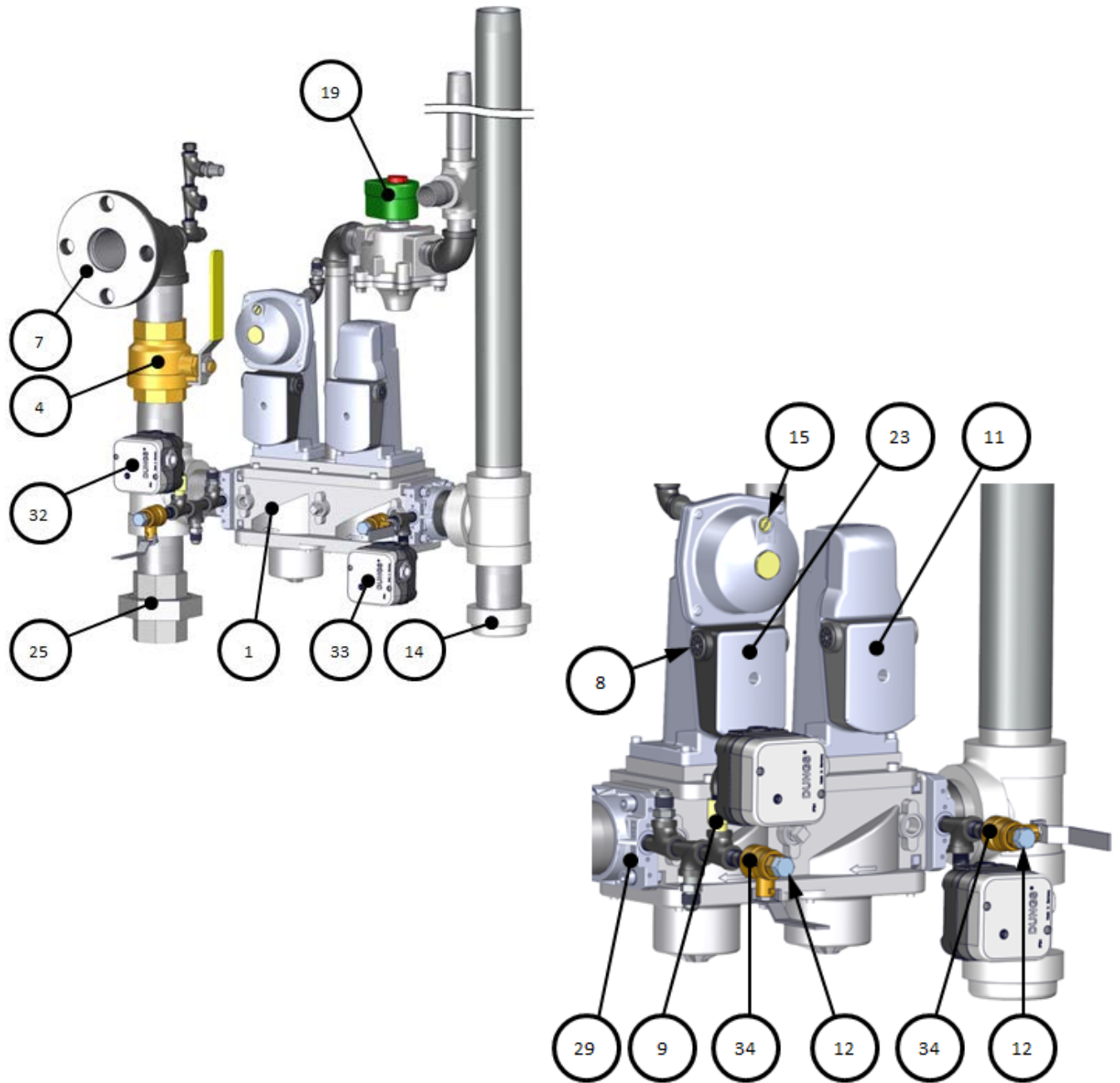

AERCO International, Inc. Blauvelt, NY 10913	Benchmark 3000DF DBB Gas Train – NATURAL GAS	01/03/2017
	22177-1 rev F, component of 22183	Sheet 1 of 1

Benchmark 3000 DF DBB PROPANE Gas Train – P/N 22178-1							
Item	Qty	Part #	Description	Item	Qty	Part #	Description
1	1	124142	VALVE: SSOV: DOUBLE BODY: 2" NPT	16	2	95030	FLANGE: SSOV 2" NPT
2	1	64048	ACTUATOR: SSOV W/ REGULATOR	22	2	92143	1/4" BALL VALVE: WATTS
3	1	27086-1	ACTUATOR: SSOV W/O P.O.C. SWITCH	24	1	60032-1	SWITCH: GAS PRESSURE 1-20" W.C.
6	2	9-22	PIPE PLUG: 1/4" NPT: STEEL	25	1	60020	SWITCH: GAS PRESSURE 2-20" W.C.
8	1	99017	SNUBBER: PRESSURE: 1/4"	29	1	123769	VALVE: SOLENOID N.O. 1" NPT
11	1	93382	2" NPT CAP	32	1	123771	UNION: MA x FEM 1" NPT: 150# M.I.
12	1	99015	DAMPING ORIFICE: SSOV	*	1	97005-5	FLEX HOSE, 18"
13	4	12951-2	BUSHING: CONTROL BOX				

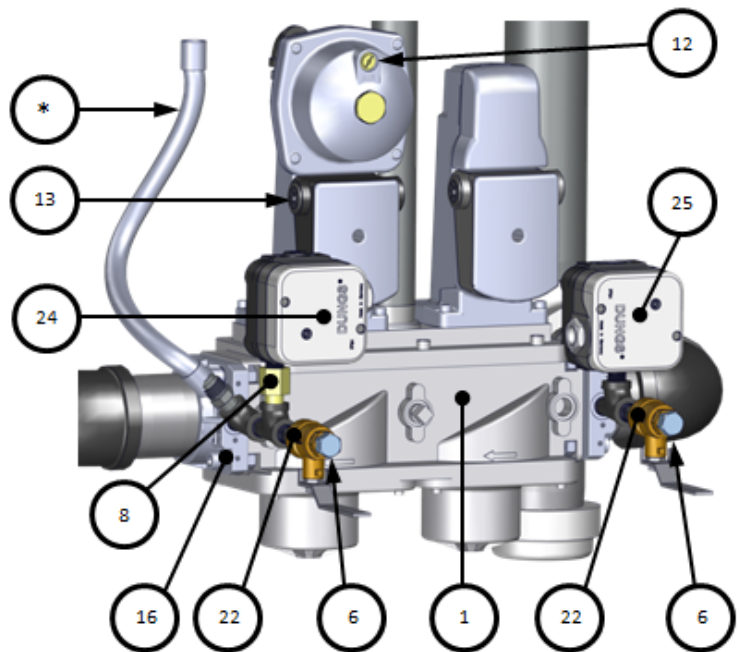
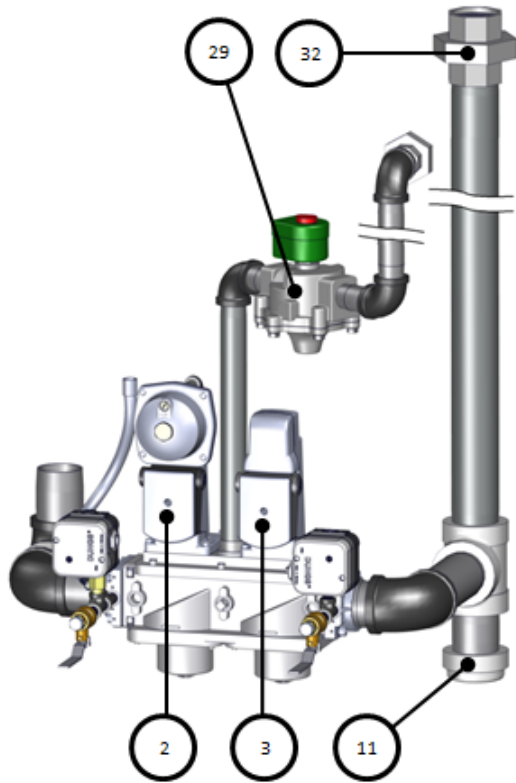

AERCO International, Inc. Blauvelt, NY 10913	Benchmark 3000 DF DBB Gas Train – PROPANE	01/05/2017
	22178-1 rev E, component of 22183	Sheet 1 of 1

APPENDIX H – BENCHMARK 2500/3000 PART LISTS

Benchmark 2500 Dual Fuel FM Gas Train, Natural Gas – P/N 22210-1

Item	Qty	Part #	Description	Item	Qty	Part #	Description
1	1	123542	FLANGE 2" 125# 2" NPT	24	2	9-22	PIPE PLUG: 1/4" NPT: STEEL
7	1	92006-7	VALVE: BALL BRASS 1-1/2" NPT	25	2	12951-2	BUSHING: CONTROL BOX
9	1	124150	VALVE: SSOV 1-1/2" NPT	27	1	99015	DAMPING ORIFICE: SSOV
10	1	64048	ACTUATOR: SSOV W/ REGULATOR	29	1	93310	1-1/2" 150# BLACK IRON UNION
14	1	93382	2" NPT CAP	30	2	99017	SNUBBER: PRESSURE: 1/4"
17	1	97087-12	TUBING: FLEXIBLE GAS 12"	32	1	61002-15	HIGH GAS PRESSURE SWITCH 7.0" W.C.
22	1	61002-21	LOW GAS PRESSURE SWITCH 7.5" W.C.	33	1	9-294	UNION: 2" NPT 300#
23	3	92077	1/4" NPT MXF BRASS BALL VALVE	34	1	61002-22	HIGH PRESSURE SWITCH 3.0

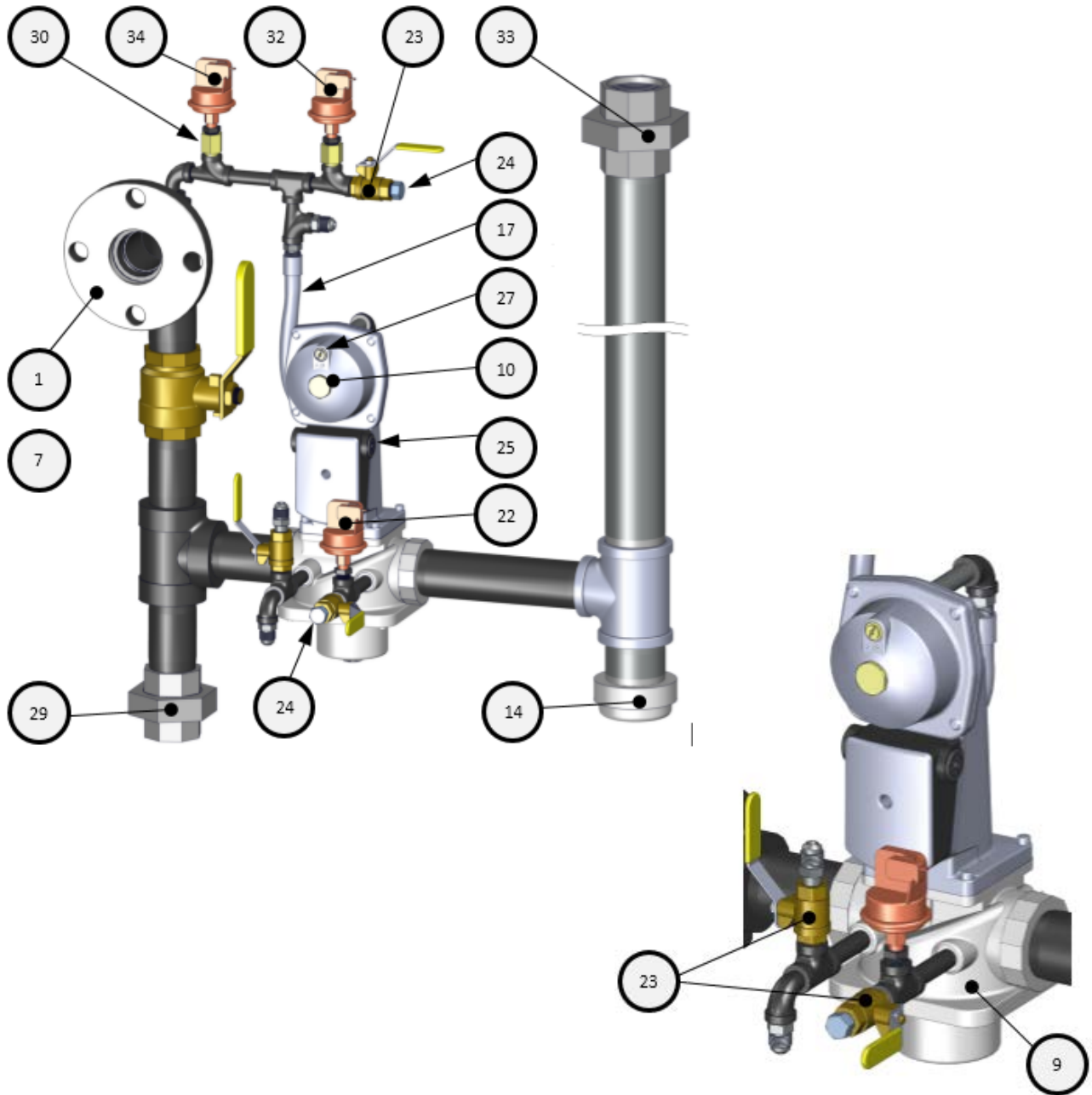

AERCO International, Inc. Blauvelt, NY 10913	Benchmark 2500 DF FM Gas Train – Natural Gas	02/19/2016
	22210-1 rev B, component of 22210	Sheet 1 of 2

Benchmark 2500 Dual Fuel FM Gas Train – Propane – P/N 22210-2							
Item	Qty	P/N	Description	Item	Qty	P/N	Description
5	1	124150	VALVE: SSOV 1-1/2" NPT	18	1	9-22	PIPE PLUG: 1/4" NPT: STEEL
6	1	64048	ACTUATOR: SSOV W/ REGULATOR	19	2	12951-2	BUSHING: CONTROL BOX
9	1	93382	2" NPT CAP	21	1	99015	DAMPING ORIFICE: SSOV
16	1	61002-11	LOW GAS PRESSURE SWITCH 3.6" W.C.	23	1	9-294	UNION: 2" NPT 300#
17	1	92077	1/4" NPT MXF BRASS BALL VALVE				

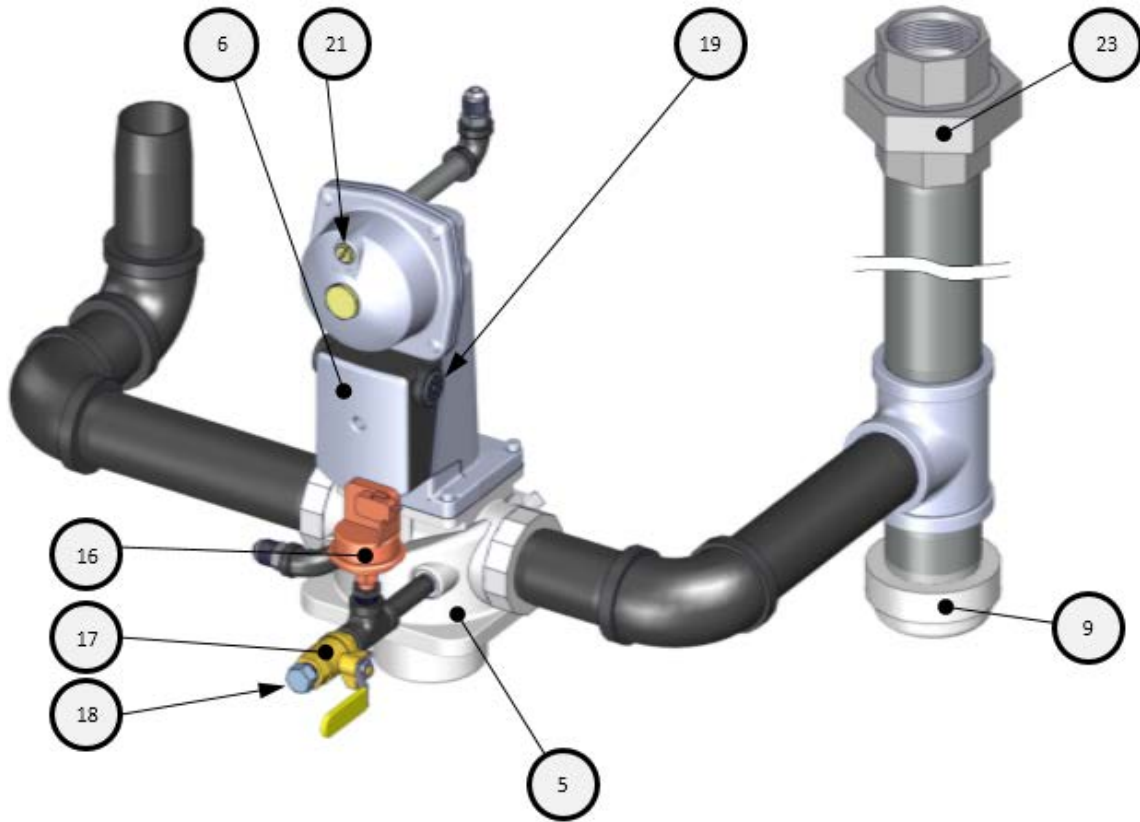

AERCO International, Inc. Blauvelt, NY 10913	Benchmark 2500 DF FM Gas Train – PROPANE	02/19/2016
	22210-2 rev B, component of 22210	Sheet 1 of 1

Benchmark 2500 DF DBB Gas Train – NATURAL GAS – P/N 22209-1

Item	Qty	Part #	Description	Item	Qty	Part #	Description
1	1	123542	FLANGE 2" 125# 2"NPT	28	2	95029	FLANGE: SSOV 1 1/2" NPT
7	1	92006-7	VALVE: BALL BRASS 1-1/2" NPT	29	1	27086-1	ACTUATOR: SSOV W/O P.O.C. SWITCH
9	1	64048	ACTUATOR: SSOV W/ REGULATOR	30	1	122774	VALVE: VENT 3/4" NPT
13	1	93382	2" NPT CAP	35	1	124094	UNION: 3/4" NPT #150
17	1	97087-12	TUBING, FLEXIBLE GAS 12"	36	1	9-294	UNION: 2" NPT 300#
21	1	61002-21	LOW GAS PRESSURE SWITCH 7.5" W.C.	39	1	93310	1-1/2" 150# BLACK IRON UNION
24	2	9-22	PIPE PLUG: 1/4" NPT: STEEL	41	2	99017	SNUBBER: PRESSURE: 1/4"
25	3	92077	1/4" NPT MXF BRASS BALL VALVE	42	1	61002-15	HIGH GAS PRESSURE SWITCH 7.0" W.C.
26	1	99015	DAMPING ORIFICE: SSOV	43	1	61002-22	SWITCH, HIGH 3.0
27	1	124137	VALVE: SSOV: DOUBLE BODY: 1-1/2" NPT				

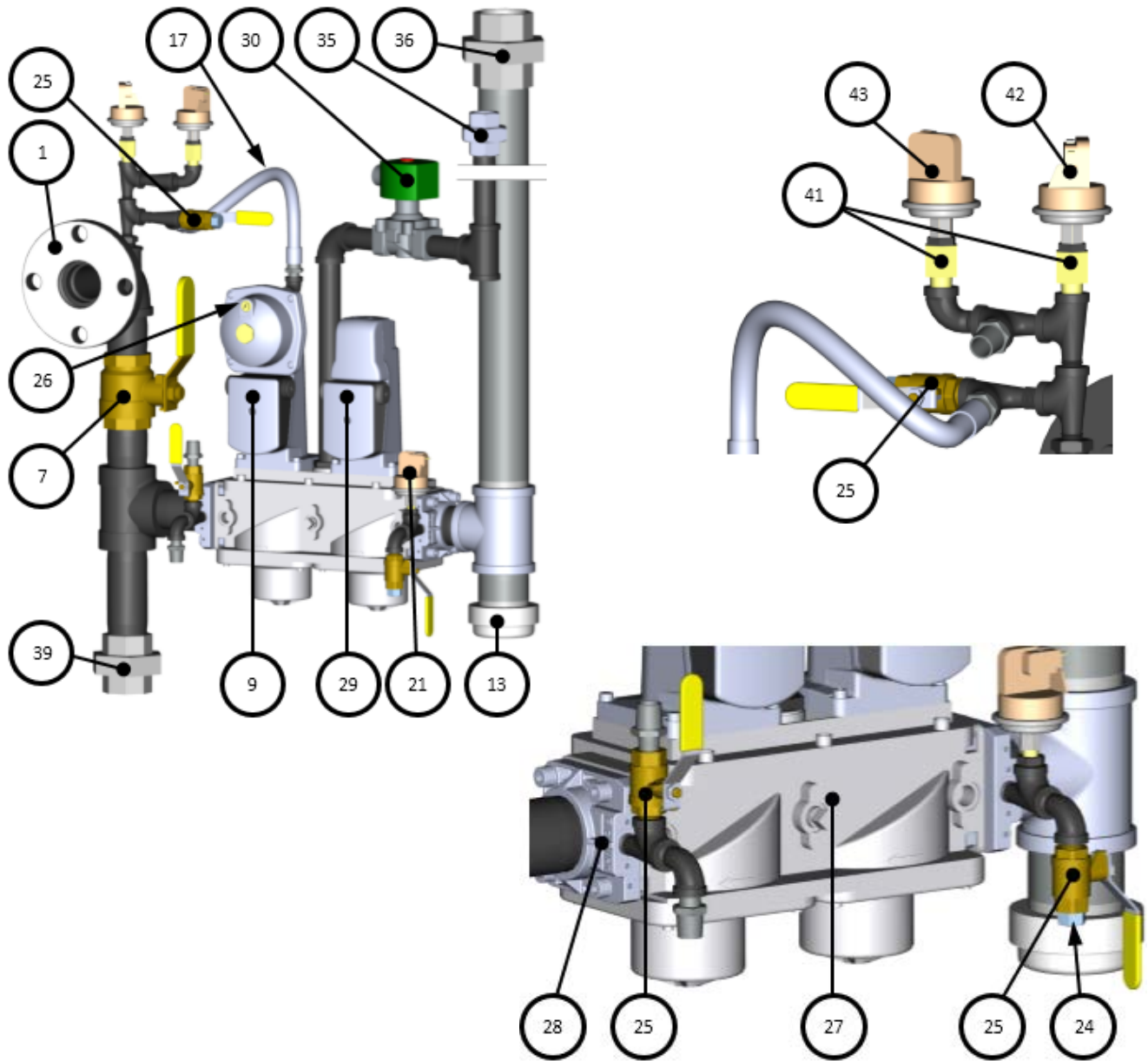

AERCO International, Inc. Blauvelt, NY 10913	Benchmark 2500DF DBB Gas Train – NATURAL GAS	02/19/2016
	22209-1 rev C, component of 22209	Sheet 1 of 1

Benchmark 2500 DF DBB Gas Train – PROPANE – P/N 22209-2

Item	Qty	Part #	Description	Item	Qty	Part #	Description
7	1	64048	ACTUATOR: SSOV W/ REGULATOR	19	1	99015	DAMPING ORIFICE: SSOV
10	1	93382	2" NPT CAP	20	1	9-294	UNION: 2" NPT 300#
15	1	61002-11	LOW GAS PRESSURE SWITCH 3.6" W.C.	22	1	124137	VALVE: SSOV: DOUBLE BODY: 1-1/2" NPT
16	1	92077	1/4" NPT MXF BRASS BALL VALVE	23	1	27086-1	ACTUATOR: SSOV W/O P.O.C. SWITCH
17	1	9-22	PIPE PLUG: 1/4" NPT: STEEL	24	2	95029	FLANGE: SSOV 1 1/2" NPT
18	4	12951-2	BUSHING, CONTROL BOX	25	1	122774	VALVE, VENT 3/4" NPT

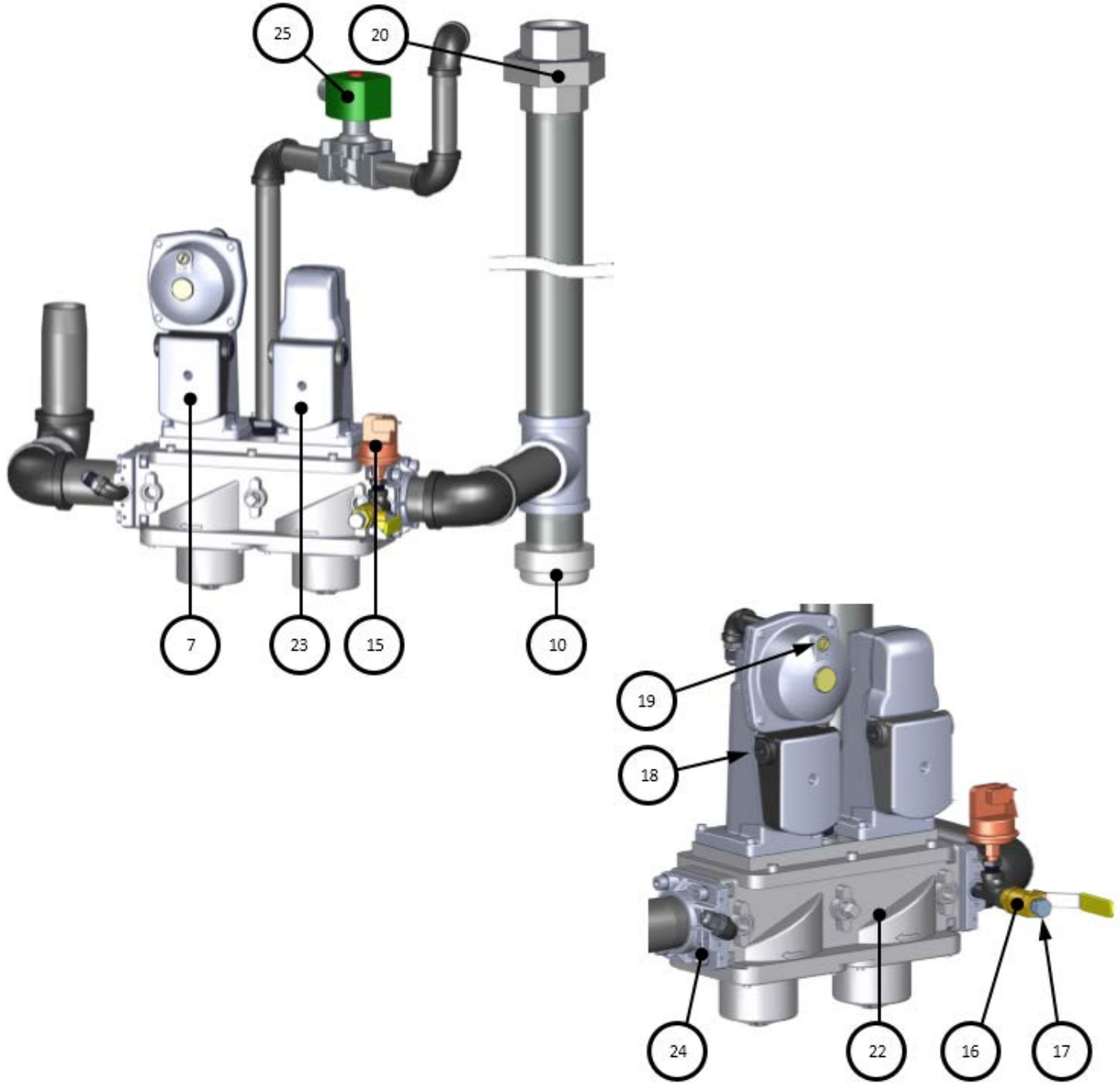

AERCO International, Inc. Blauvelt, NY 10913	Benchmark 2500 DF DBB Gas Train PROPANE	03/23/2016
	22209-2 rev C, component of 22209	Sheet 1 of 1

Burner Assembly BMK 2500 P/N 26015-TAB, BMK 3000 P/N 26014-TAB							
Item	Qty	Part #	Description	Item	Qty	Part #	Description
1	1	43091	BLOWER PLENUM (MACHINING)	13	1	60011-5	BLOWER PROOF SWITCH, BMK 2500
2	1	See Table	3 PHASE BLOWER Replacement Kit			60011-2	BLOWER PROOF SWITCH, BMK 3000
3	1	43090	AIR FUEL VALVE PLENUM	14	1	61002-5	BLOCKED INLET SWITCH -4.5" W.C.
4	1	46039	BURNER: BMK 2500	15	2	9-22	PIPE PLUG: 1/4" NPT: STEEL
		46038	BURNER: BMK 3000	17	1	81057	GASKET: BLOWER
5	1	See Table	A/F VALVE ASSY Replacement Kit	19	1	81157	BLOWER GASKET
6	1	59104	OBSERVATION PORT	25	1	123449	AIR INLET TEMPERATURE SENSOR
7	1	61026	LEAN OXYGEN SENSOR	27	1	88015	O RING, 3/16 x 7"
8	1	66034	FLAME ROD	31	1	93230	SNUBBER
9	1	66026	IGNITOR-INJECTOR	32	1	81180	GASKET: BURNER
10	1	81048	GASKET: FLAME ROD LOW NOX	33	1	81173	RELEASE GASKET
11	1	24277	STAGED IGNITION ASSY	34	1	81185	RELEASE GASKET: LOWER

Description	Item 2	Item 5	
		BMK 2500	BMK 3000
460VAC SINGLE FUEL	58063-1	24311-8	24311-1
208VAC SINGLE FUEL	58063-2	24311-8	24311-1
460VAC DUAL FUEL	58063-1	24311-9	24311-7
208VAC DUAL FUEL	58063-2	24311-9	24311-7

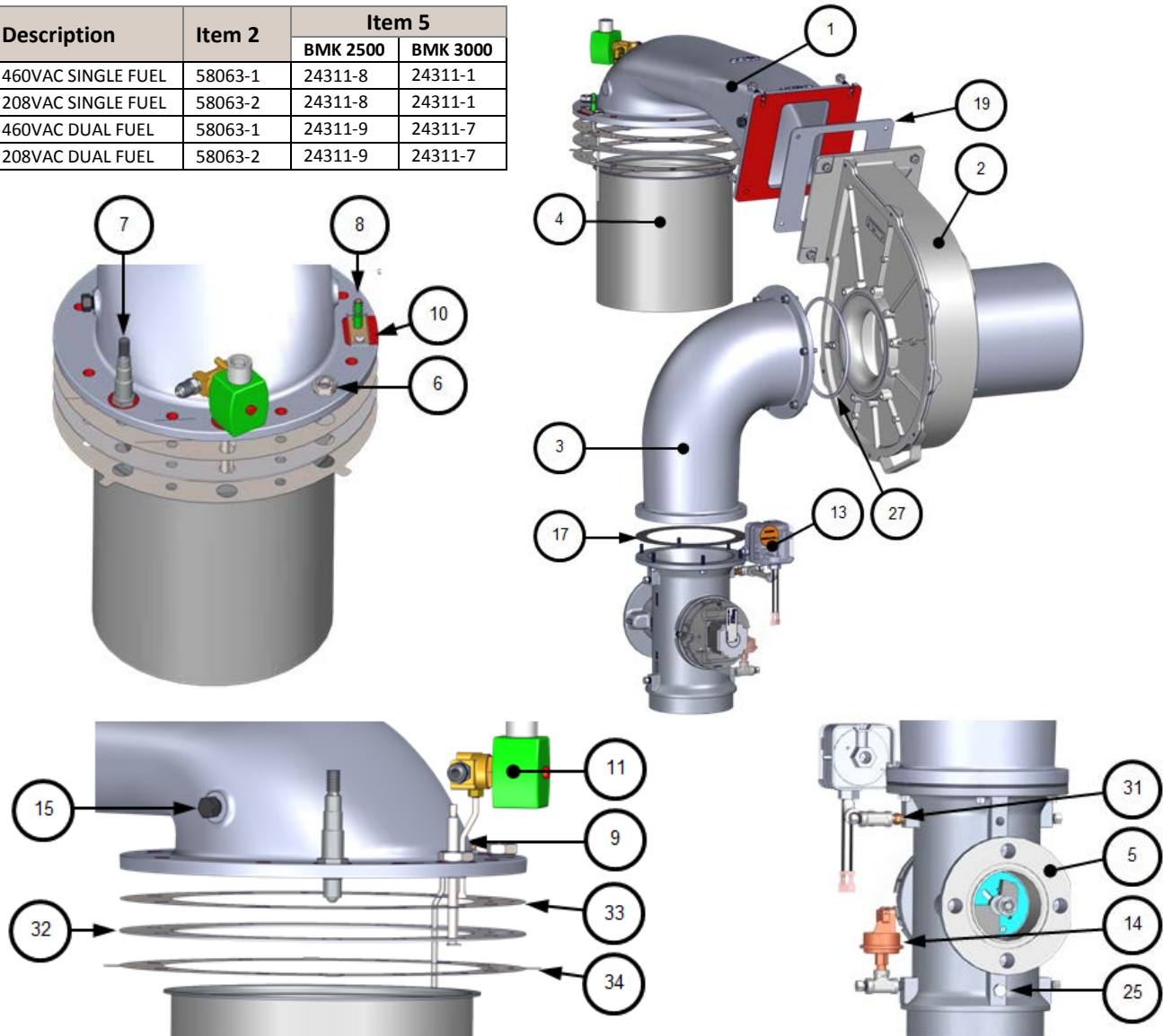

AERCO International, Inc. Blauvelt, NY 10913	Benchmark 2500 - 3000 Burner Assembly	08/12/2015
	BMK 2500 – 26015-TAB rev F BMK 3000 – 26014-TAB rev J	Sheet 1 of 1

Appendix I: WIRING DIAGRAMS

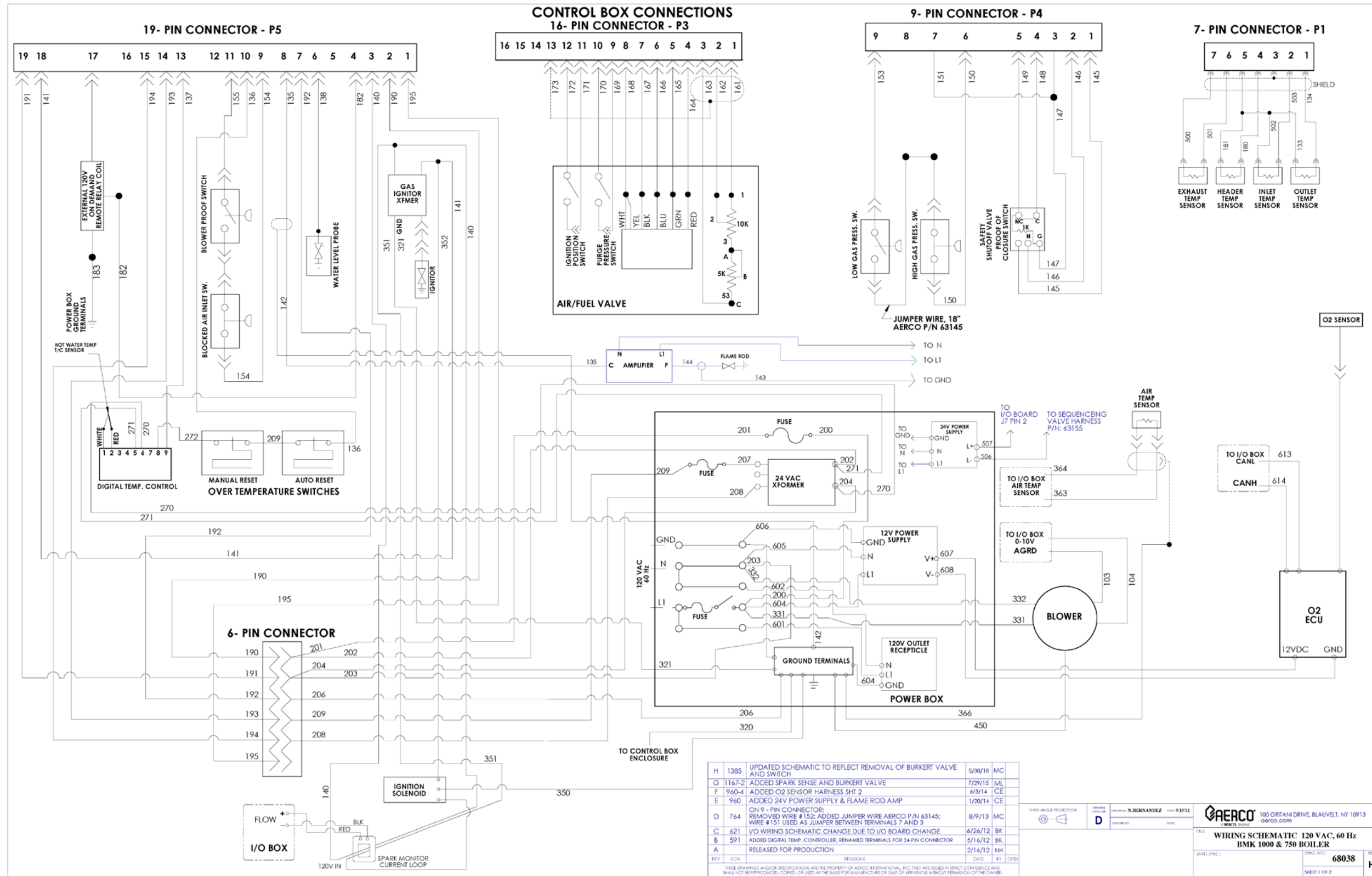

REV	ECN	DESCRIPTION	DATE	BY	CHKD
H	1385	UPDATED SCHEMATIC TO REFLECT REMOVAL OF BURKERT VALVE AND SWITCH	5/30/18	MC	
G	1167-2	ADDED SPARK SENSE AND BURKERT VALVE	7/29/15	ML	
F	960-4	ADDED O2 SENSOR HARNESS SH1 2	6/3/14	CE	
E	960	ADDED 24V POWER SUPPLY & FLAME ROD AMP	1/20/14	CE	
D	764	ON 9-PIN CONNECTOR: REMOVED WIRE #152; ADDED JUMPER WIRE AERCO P/N 63145; WIRE #151 USED AS JUMPER BETWEEN TERMINALS 7 AND 3	8/9/13	MC	
C	621	I/O WIRING SCHEMATIC CHANGE DUE TO I/O BOARD CHANGE	6/26/12	BK	
B	591	ADDED DIGITAL TEMP. CONTROLLER; RENAMED TERMINALS FOR 24-PIN CONNECTOR	5/16/12	BK	
A		RELEASED FOR PRODUCTION	2/16/12	NH	

THIRD ANGLE PROJECTION

ORIGIN: D

DESIGNER: N.HERNANDEZ

DATE: 9/19/11

100 ORTANI DRIVE, BLAUVELT, NY 10913

aerco.com

AERCO

FILE: WIRING SCHEMATIC 120 VAC, 60 Hz BMK 1000 & 750 BOILER

DATE: 6/26/12

REV: H

68038

SHEET 1 OF 2

Benchmark 750/1000 – Drawing Number: 68038 rev H Sheet 1 of 2

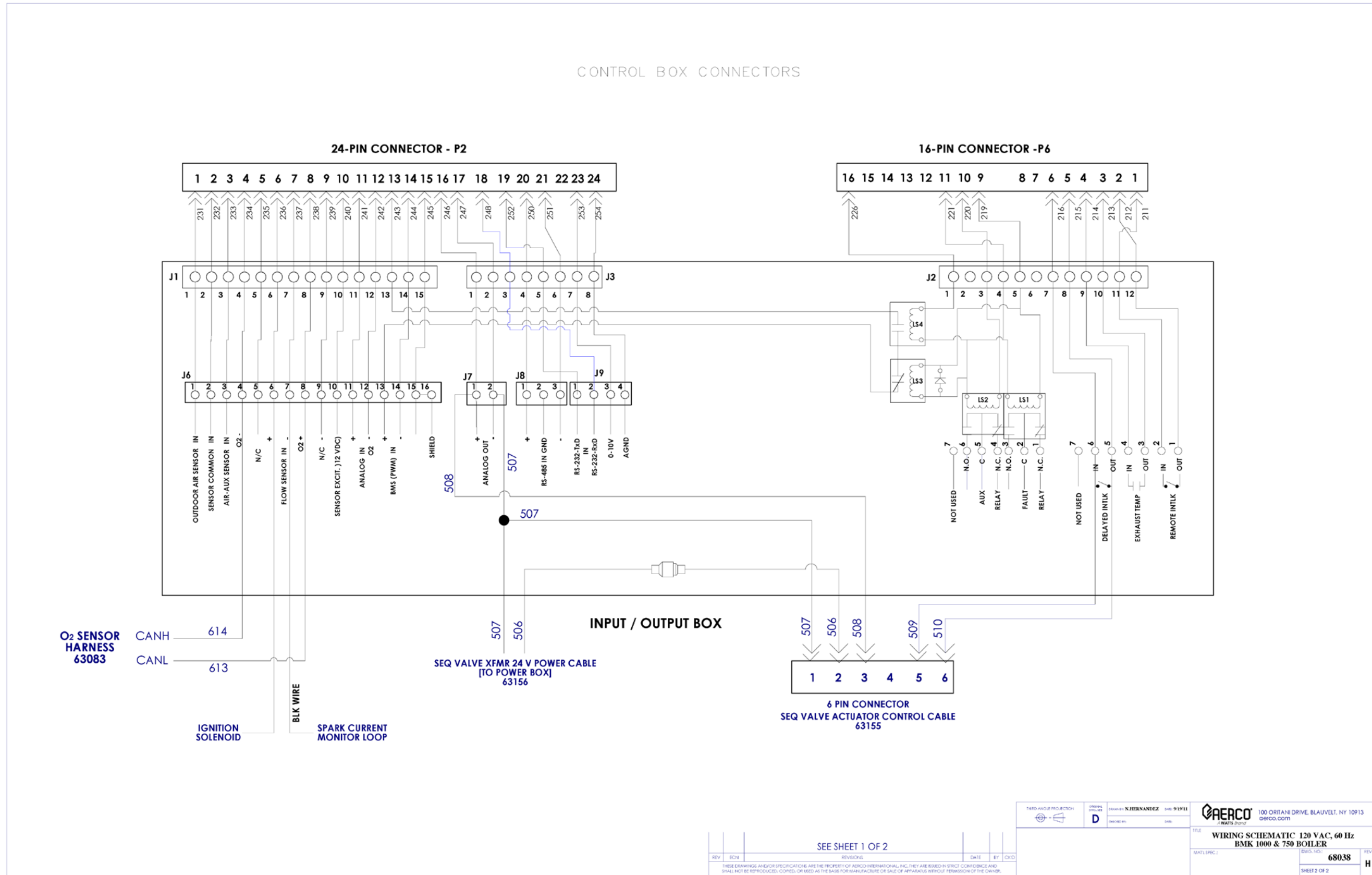

Benchmark 750/1000 – Drawing Number: 68038 rev H Sheet 2 of 2

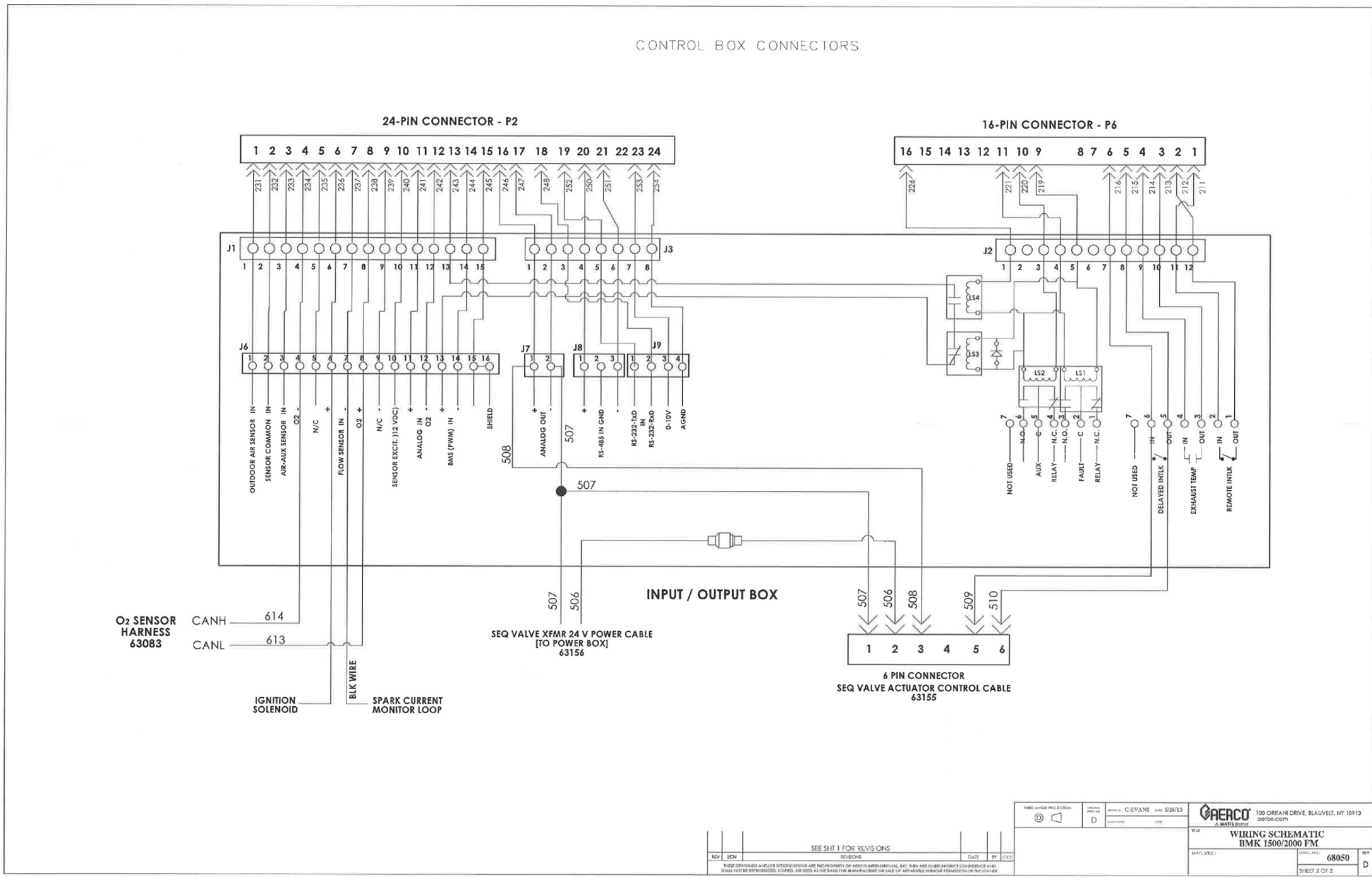

THIRD ANGE PROJECTIONS		DESIGNED BY: C. EVANS	DATE: 5/26/13	100 ORSANI DRIVE, BLAUVELT, NY 10913 aerco.com
SEE SHIT 1 FOR REVISIONS		DRAWING NO: D	DATE:	
THESE DRAWINGS AND/OR SPECIFICATIONS ARE THE PROPERTY OF AERCO-BENEFICIAL, INC. THEY ARE LOANED TO YOUR COMPANY AND SHALL NOT BE REPRODUCED, COPIED, OR USED AS THE BASIS FOR MANUFACTURE OR SALE OF APPARATUS WITHOUT PERMISSION OF THE OWNER.				TITLE: WIRING SCHEMATIC BMK 1500/2000 FM MAIL SPEC: 68050 SHEET 2 OF 2

Benchmark 1500/2000 – Drawing Number 68050 rev D page 2 of 2

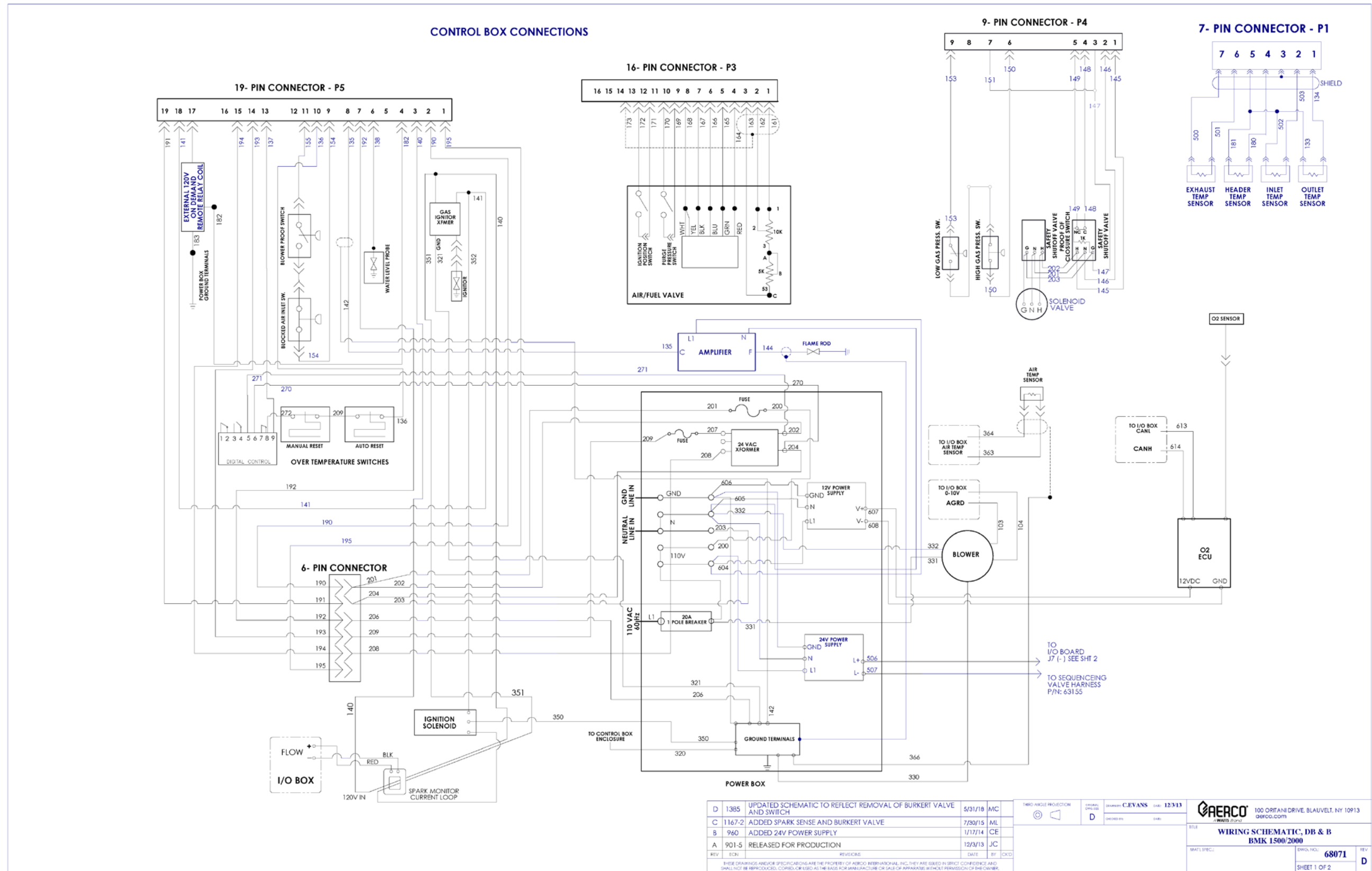

Benchmark 1500/2000 DBB – Drawing Number 68071 rev D page 1 of 2

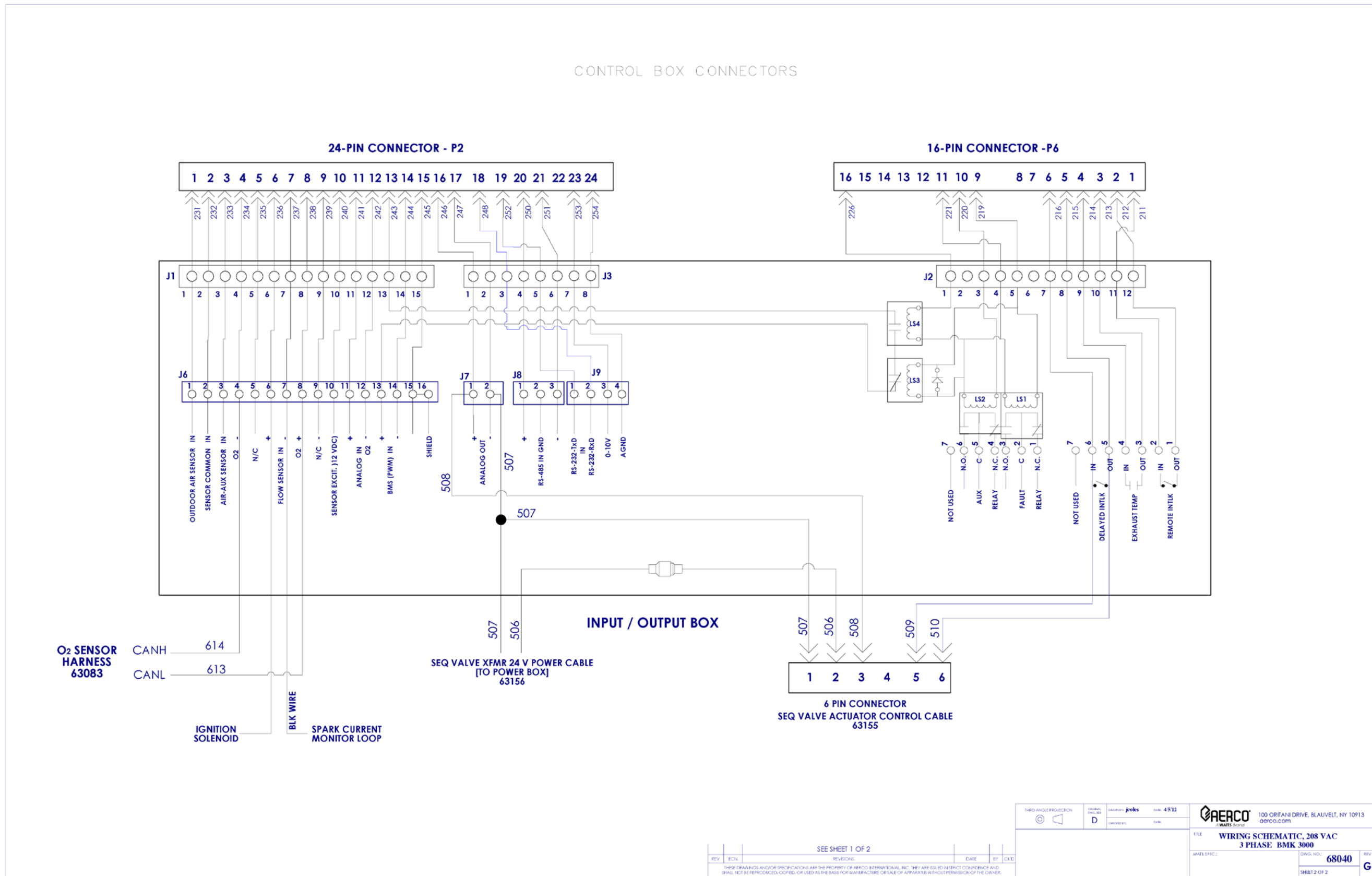

Benchmark 3000 208 VAC – Drawing Number: 68040 rev G, Sheet 2 of 2

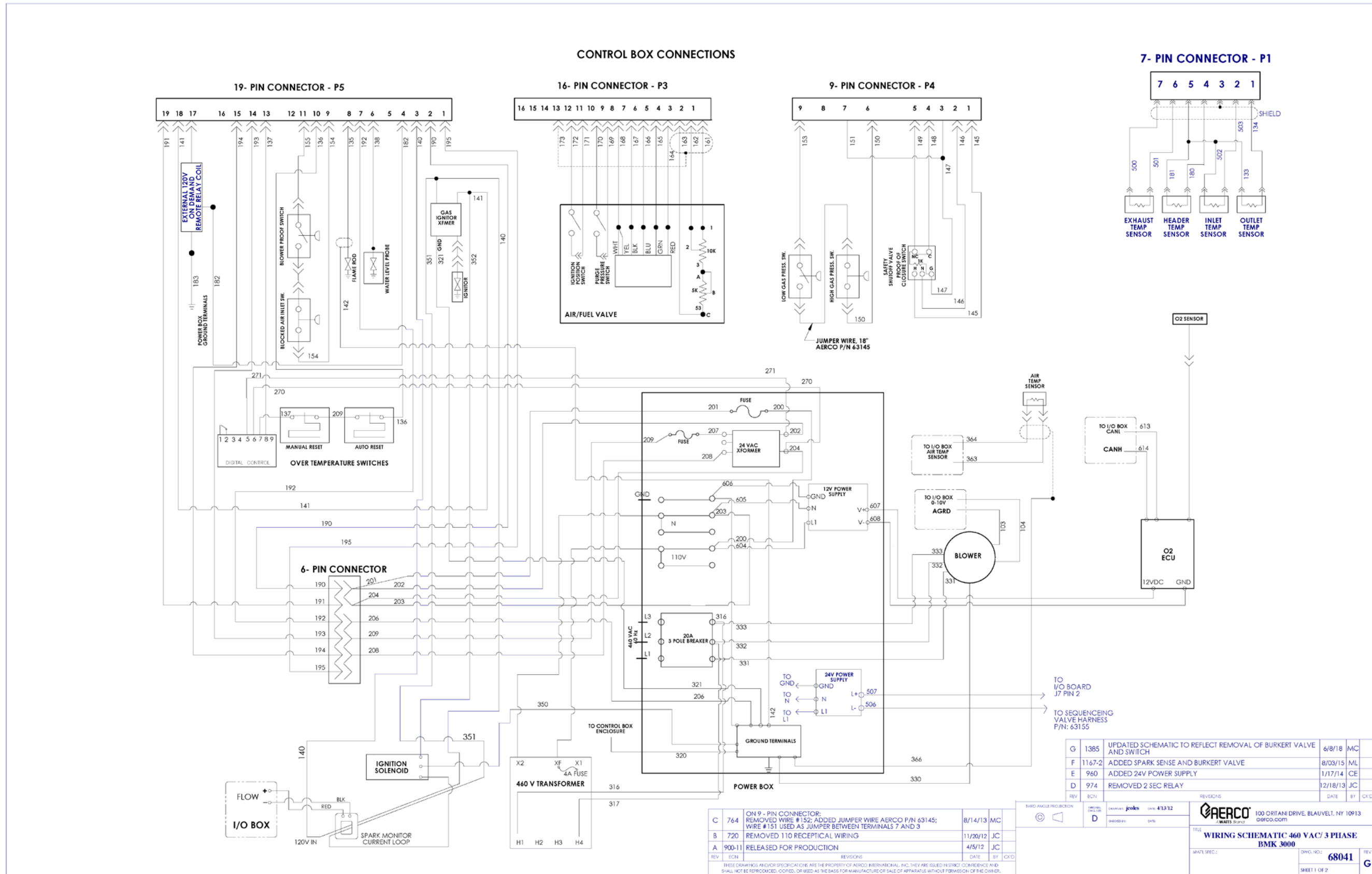

Benchmark 3000 460 VAC – Drawing Number: 68041 rev G Sheet 1 of 2

CONTROL BOX CONNECTORS

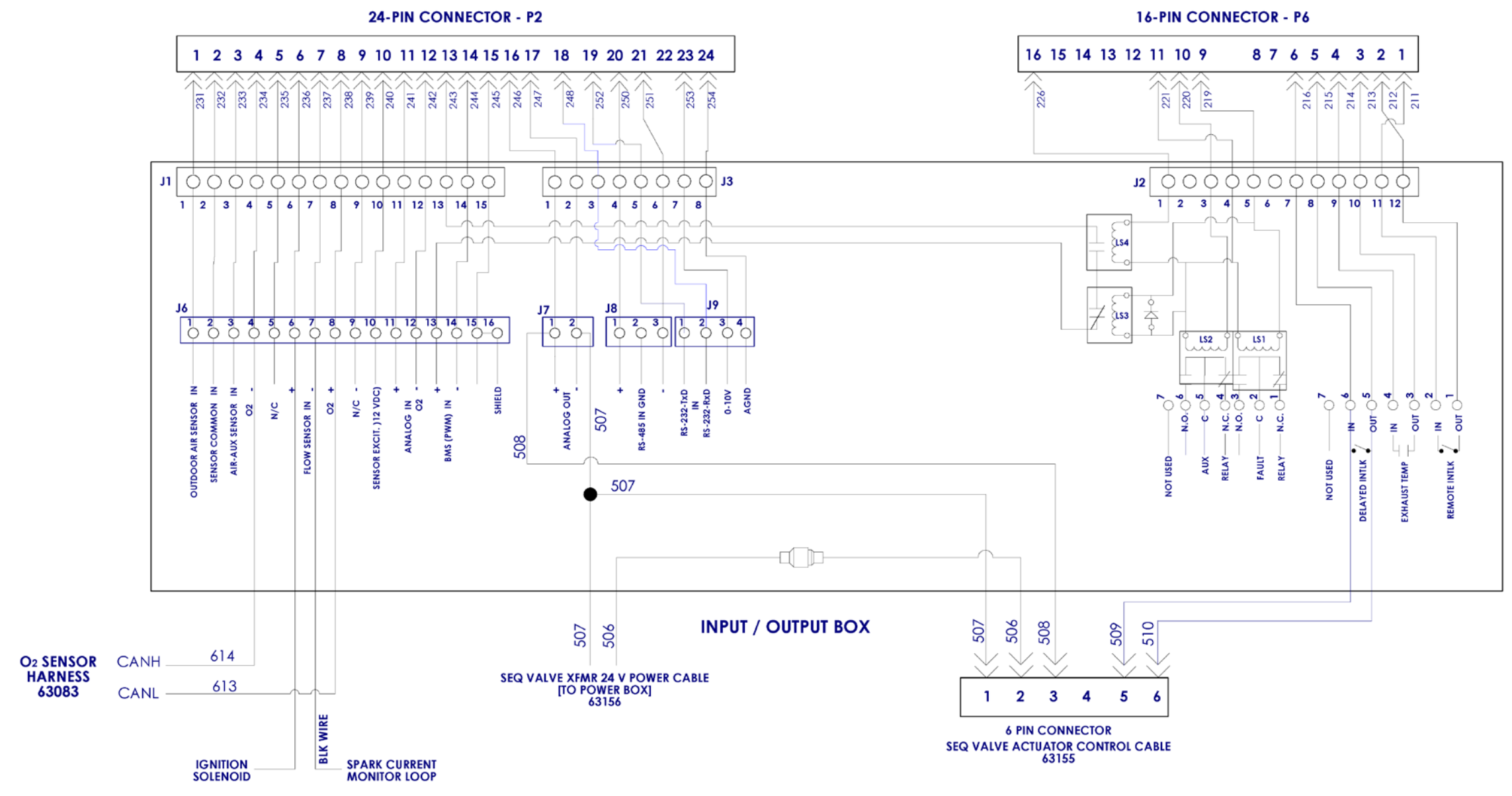

THIRD ANGLE PROJECTION		DESIGN: jules	DATE: 4/13/12	100 ORTANI DRIVE, BLAUVELT, NY 10913 aerco.com
REV	DCN	REVISIONS	DATE	
SEE SHEET 1 OF 2				TITLE: WIRING SCHEMATIC, 460 VAC / 3 PHASE BMK 3000
<small>THESE DRAWINGS AND/OR SPECIFICATIONS ARE THE PROPERTY OF AERCO INTERNATIONAL, INC. THEY ARE ISSUED IN STRICT CONFIDENCE AND SHALL NOT BE REPRODUCED, COPIED, OR USED AS THE BASIS FOR MANUFACTURE OR SALE OF APPARATUS WITHOUT PERMISSION OF THE OWNER.</small>				DWG. NO.: 68041 SHEET 2 OF 2

Benchmark 3000 460 VAC – Drawing Number: 68041 rev G Sheet 2 of 2

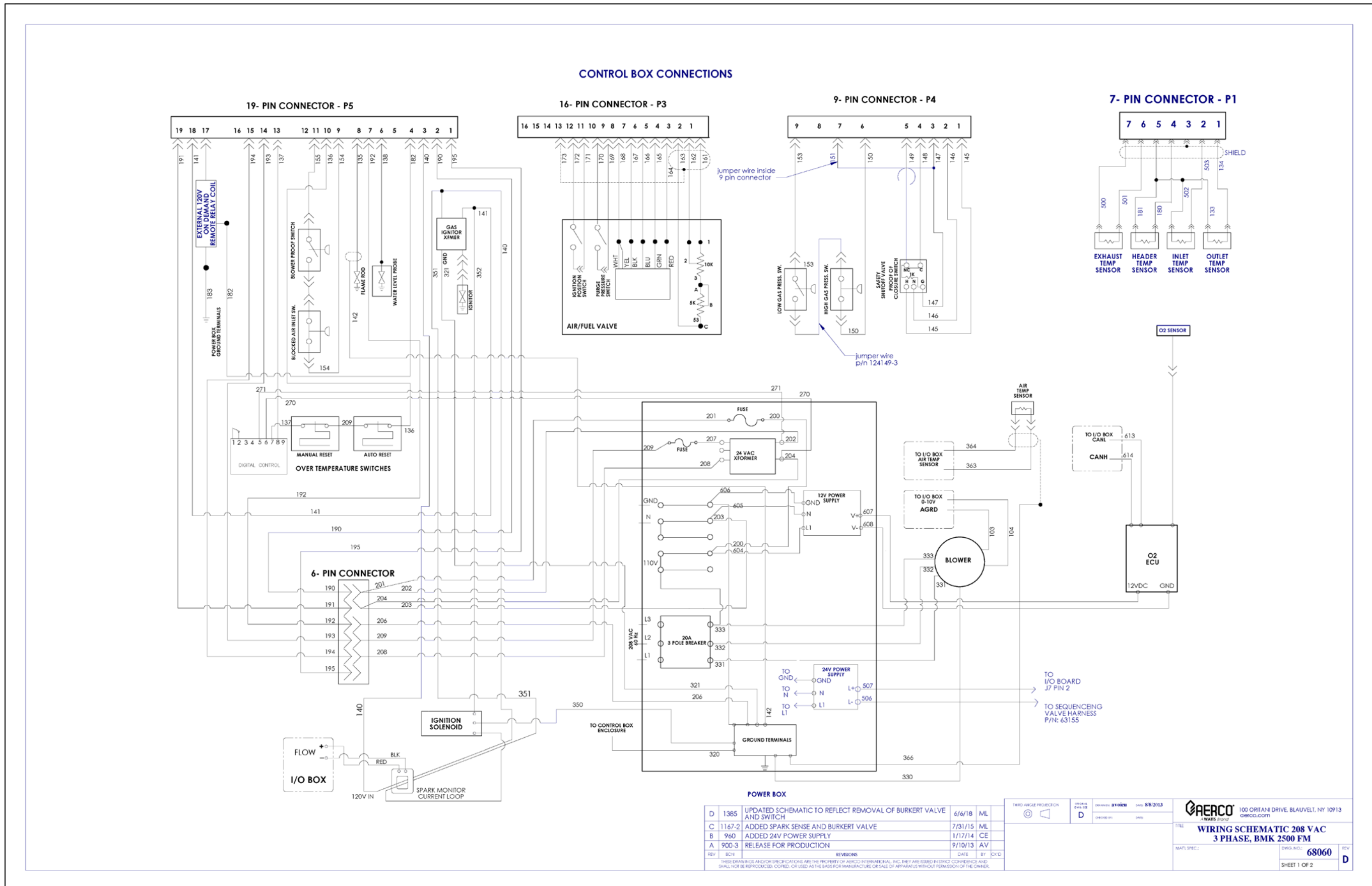

Benchmark 2500 208 VAC – Drawing Number: 68060 rev D Sheet 1 of 2

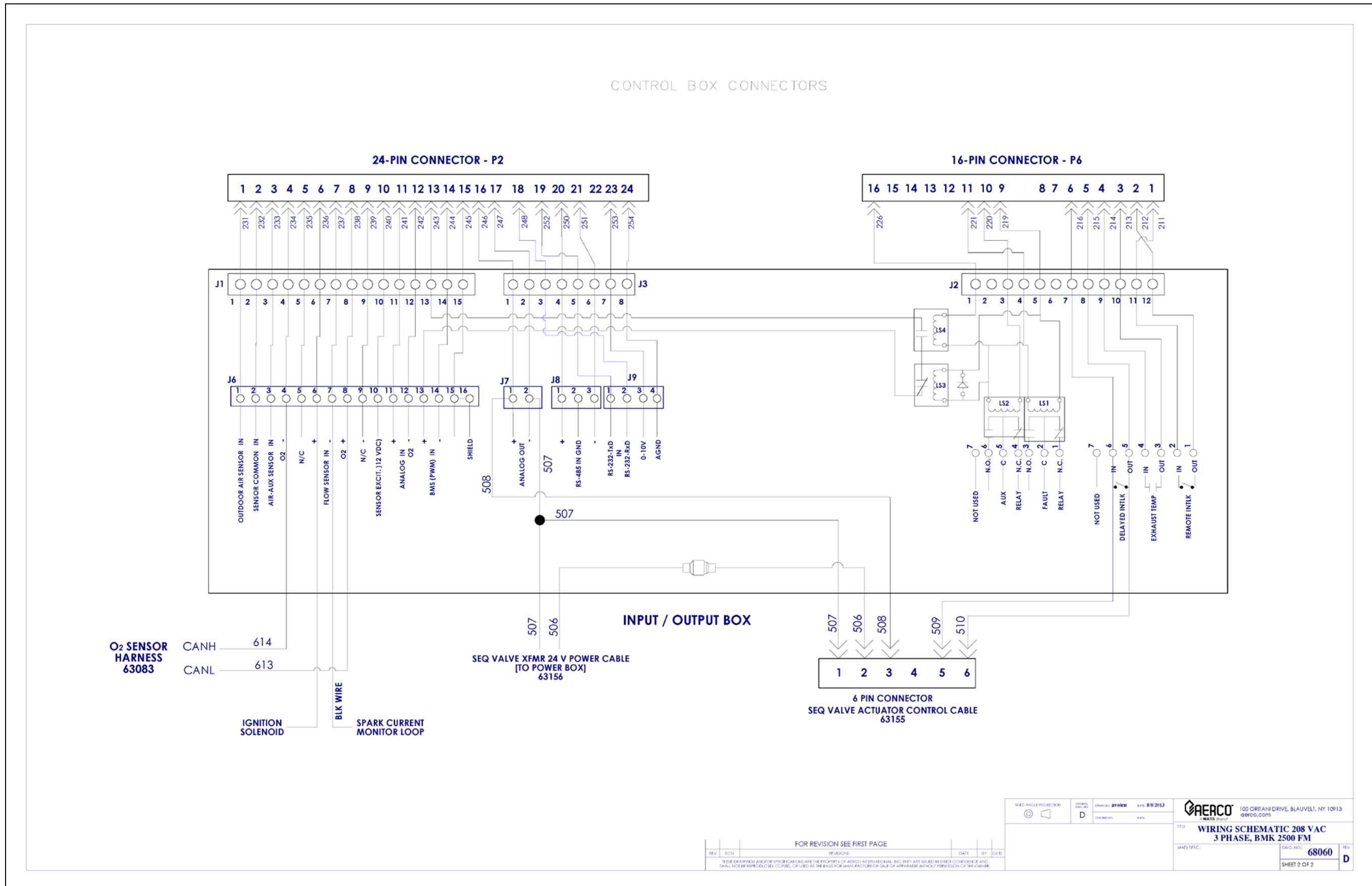

Benchmark 2500 208 VAC – Drawing Number: 68060 rev D Sheet 2 of 2

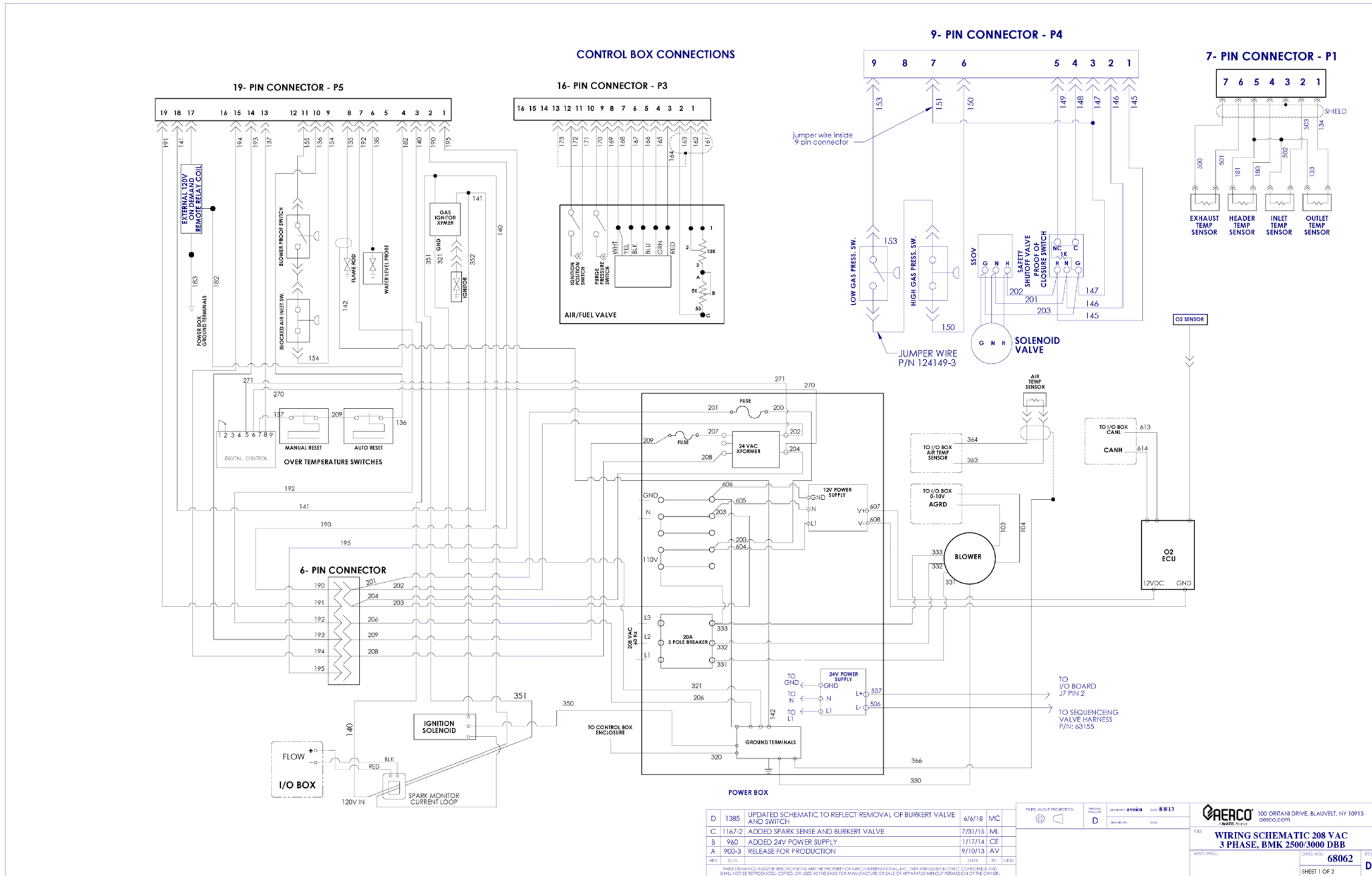

D	1385	UPDATED SCHEMATIC TO REFLECT REMOVAL OF BURKERT VALVE AND SWITCH	6/6/18	MC
C	1167-2	ADDED SPARK SENSE AND BURKERT VALVE	7/31/15	ML
B	960	ADDED 24V POWER SUPPLY	1/17/14	CE
A	900-3	RELEASE FOR PRODUCTION	9/10/13	AV
REV	ECN	DATE	DATE	BY

THIRD ANGLE PROJECTION		DESIGNED BY: AVYOKU	DATE: 8-8-13
DRAWN BY: D		DATE:	

AERCO <small>A WATTS Brand</small>		100 ORTANI DRIVE, BLAUVELT, NY 10913 909CO.COM	
TITLE: WIRING SCHEMATIC 208 VAC 3 PHASE, BMK 2500/3000 DBB			
MATERIAL SPEC:	DWG. NO.: 68062	REV:	D
SHEET 1 OF 2			

Benchmark 2500/3000 208 VAC DBB – Drawing Number: 68062 rev D Sheet 1 of 2

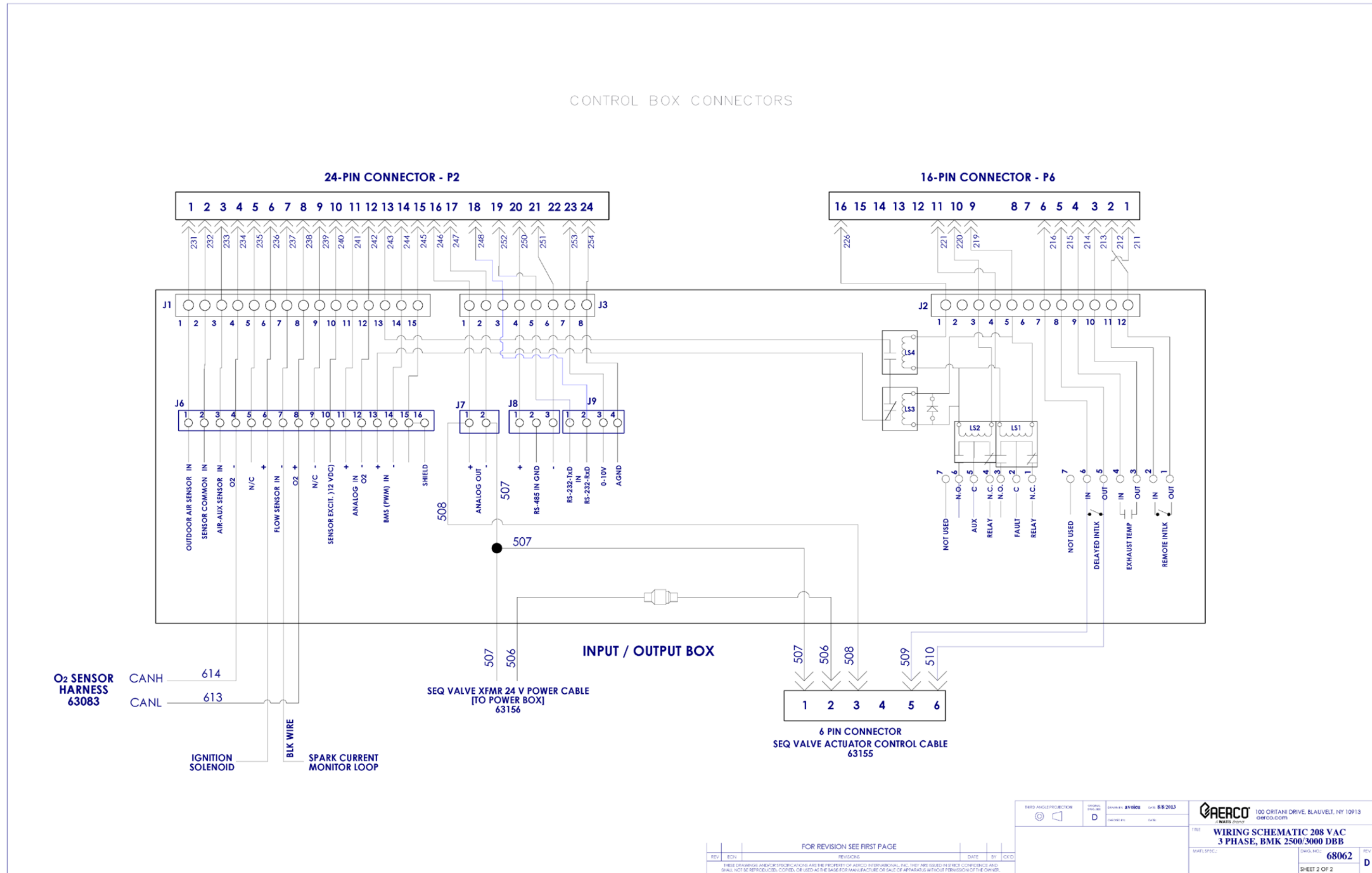

Benchmark 2500/3000 208 VAC DBB – Drawing Number: 68062 rev D Sheet 2 of 2

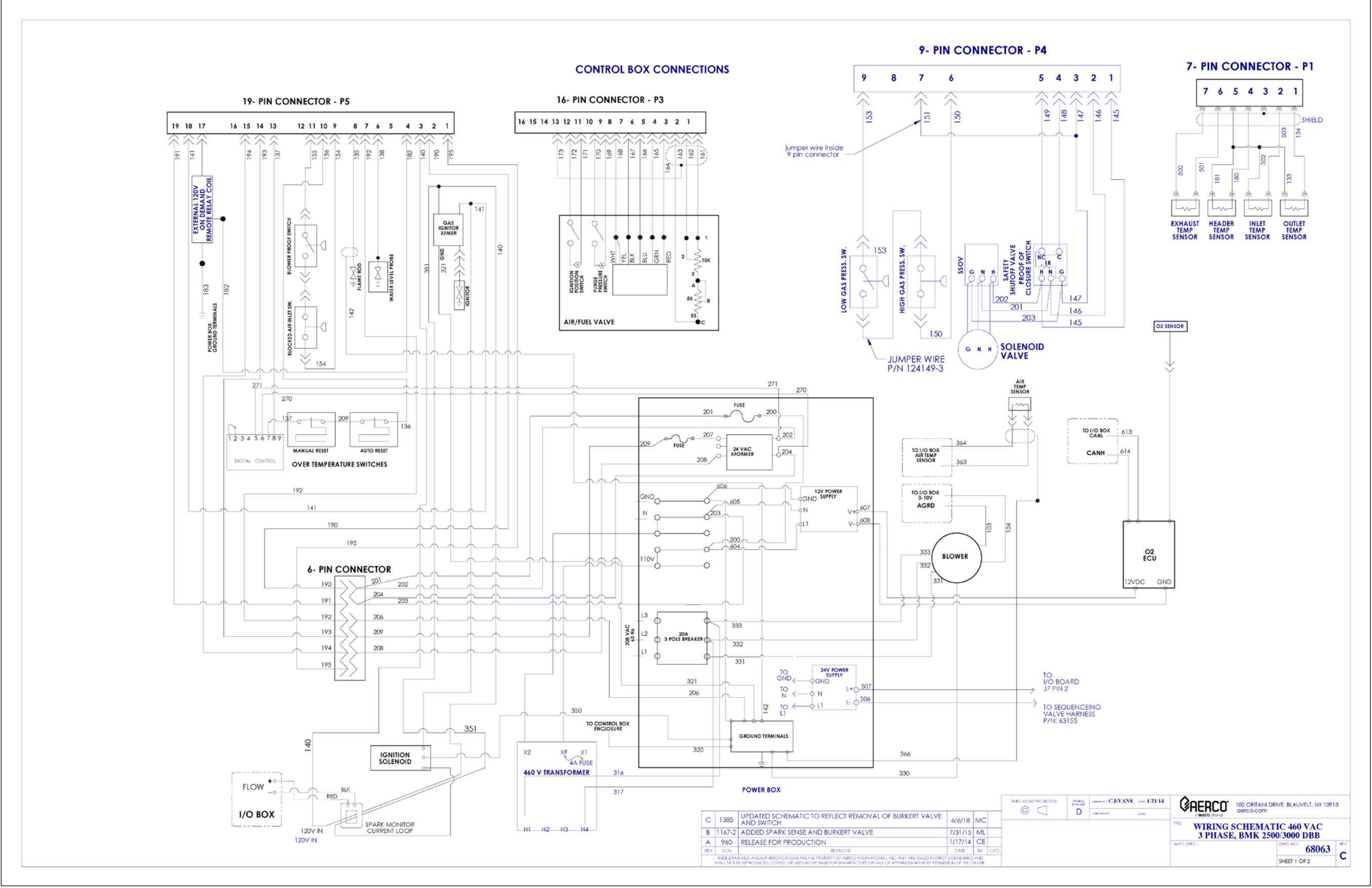

Benchmark 2500/3000 460 VAC DBB – Drawing Number: 68063 rev C Sheet 1 of 2

REV	ECN	DESCRIPTION	DATE	BY	CHKD
C	1385	UPDATED SCHEMATIC TO REFLECT REMOVAL OF BURKERT VALVE AND SWITCH	6/6/18	MC	
B	1167-2	ADDED SPARK SENSE AND BURKERT VALVE	7/31/15	ML	
A	960	RELEASE FOR PRODUCTION	1/17/14	CE	

DRW'N AND PRODUCTION	DESIGNED BY	DATE	1/21/14
DRW'N	CEVANS	DATE	
AERCO <small>A WATTS Brand</small>			
100 ORTANI DRIVE, BLAUVELT, NY 10913 OSRFO.COM			
TITLE			REV
WIRING SCHEMATIC 460 VAC			
3 PHASE, BMK 2500/3000 DBB			
MATERIAL SPEC.			68063
DRAWING NO.			C
SHEET 1 OF 2			

CONTROL BOX CONNECTORS

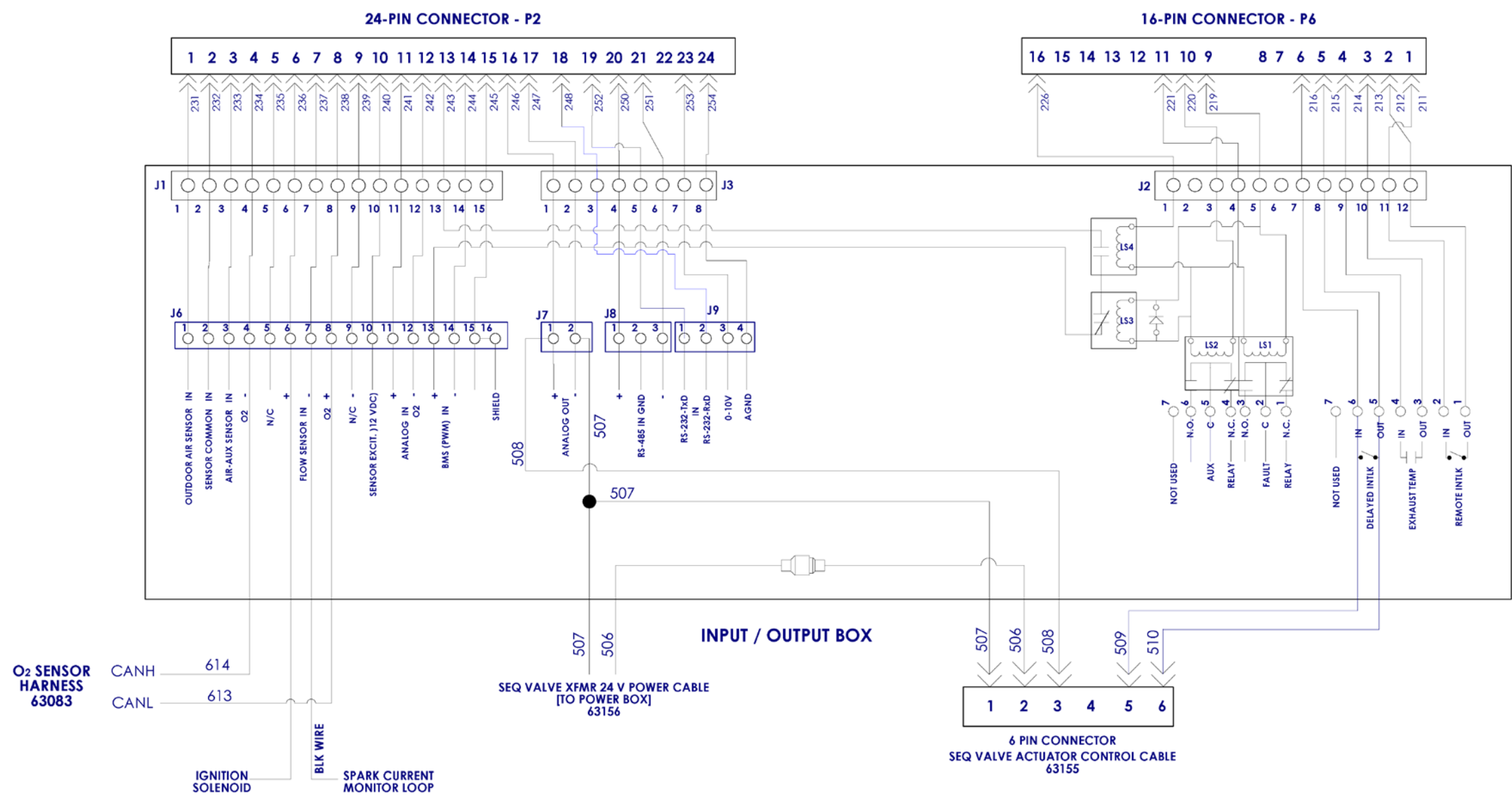

THIRD ANGLE PROJECTION		DESIGNED BY: C. EVANS	DATE: 12/1/14	100 ORITANI DRIVE, BLAUVELT, NY 10913 a.watts.brand aercoco.com	
FOR REVISION SEE FIRST PAGE		OWNERS: D	DATE:		
REV	ECN	REVISION	DATE	BY	CHK'D
<small>THESE DRAWINGS AND/OR SPECIFICATIONS ARE THE PROPERTY OF AERCO INTERNATIONAL, INC. THEY ARE ISSUED IN STRICT CONFIDENCE AND SHALL NOT BE REPRODUCED, COPIED, OR USED AS THE BASIS FOR MANUFACTURE OR SALE OF APPARATUS WITHOUT PERMISSION OF THE OWNER.</small>					
TITLE: WIRING SCHEMATIC 460 VAC 3 PHASE, BMK 2500/3000 DBB				DWG. NO.: 68063	REV: C
MATERIAL SPEC:				SHEET 2 OF 2	

Benchmark 2500/3000 460 VAC DBB – Drawing Number: 68063 rev C Sheet 2 of 2

Appendix J: C-MORE CONTROLLER VIEWS

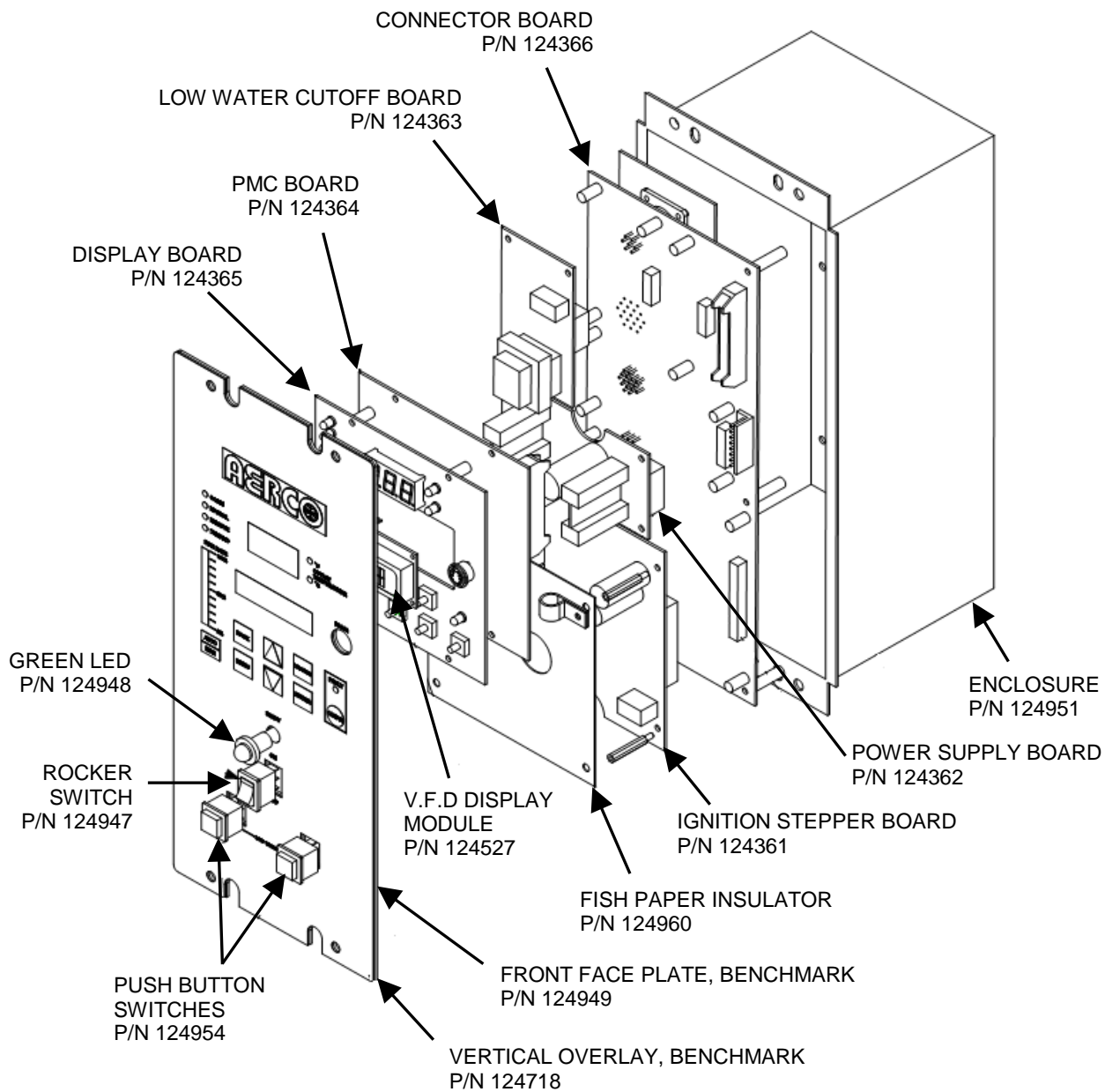

Figure J-1 – C-More Controller - Exploded View

APPENDIX J – C-MORE CONTROLLER VIEWS

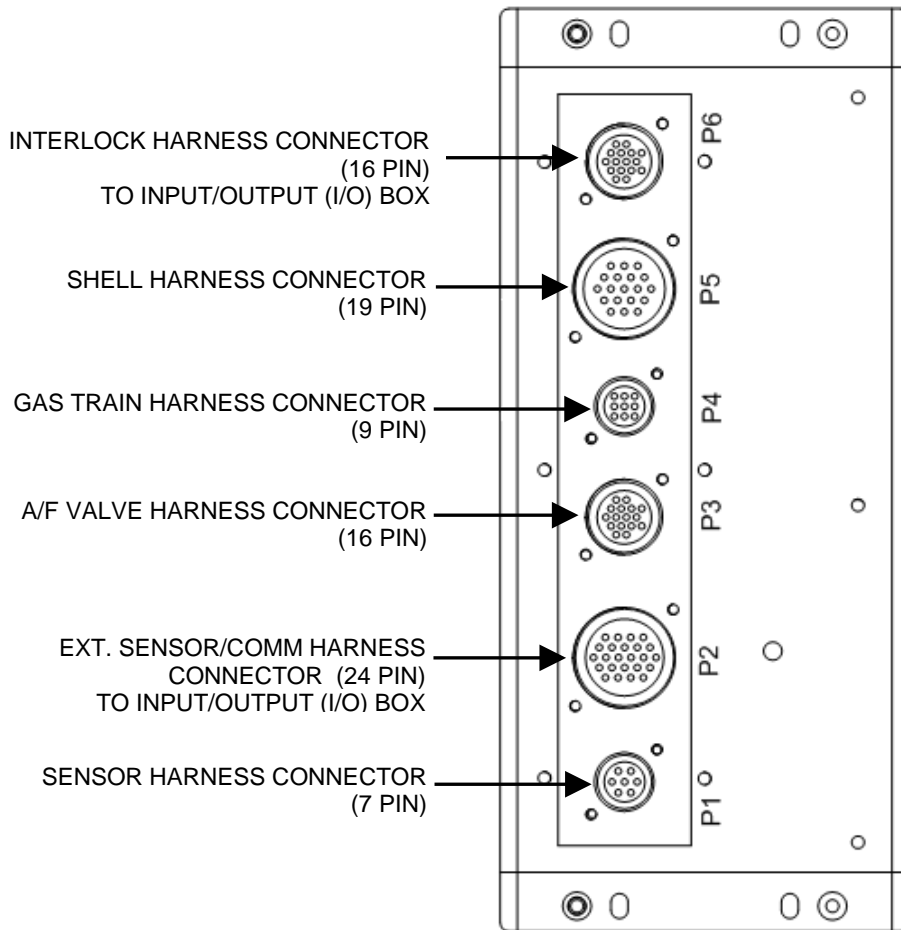

Figure J-2: C-More Controller Rear View

Appendix K: RECOMMENDED SPARES

NOTE:

Refer to the Parts List Illustrations in Appendix F – H for the locations of the recommended and optional spare parts listed in the following tables.

TABLE K-1: Recommended Emergency Spare Parts

DESCRIPTION	BMK 750/1000	BMK 1500/2000	BMK 2500/3000
120 VAC Blower Replacement Kit	58061	58038	58063-1 – 460V 58063-2 – 208V
SSOV Actuator/Regulator Combo - Used on: <ul style="list-style-type: none"> • ALL FM gas trains • Downstream SSOV on DBB gas trains 	64048	64048	64048
SSOV Actuator <u>Without</u> Proof of Closure Switch - Used on: <ul style="list-style-type: none"> • Upstream SSOV on DBB gas trains 	27086-1	27086-1	27086-1
Temperature Switch - Manual Reset	123552	123552	123552

TABLE K-2: Recommended Spare Parts For Maintenance

DESCRIPTION	PART NUMBER
Annual Maintenance Kit	BMK 750 – 3000: 58025-01
24-month Waterside/Fireside Inspection Kit	BMK 750/1000: 58025-08
	BMK 1500/2000: 58025-13
	BMK 2500/3000: 58025-10

TABLE K-3: Optional Spare Parts

DESCRIPTION	PART NUMBER	
C-More Controller	69186-4	
Burner	BMK 750/1000	46026
	BMK 1500	46042
	BMK 2000	46044
	BMK 2500	46039
	BMK 3000	46038
Lean Oxygen Sensor	61026	

CHANGE LOG

Change Log:		
Date	Description	Changed By
11/29/2017	<p>Rev C: DIR 17-070: Removed manufacturer name from high gas pressure switch DIR 17-080: Verified and corrected part numbers in Appendix F through G, standardized C-More Controller naming convention.</p>	Chris Blair
5/9/2019	<p>Rev D: DIR 18-05: Replaced schematic drawings in Appendix I DIR 18-16: Modified corrective action for "SSOV Fault During Run" in Troubleshooting DIR 18-27: Corrected burner part numbers: BMK 2500 – 46039, BMK 3000 – 46038 DIR 18-45: Changed part number of Gas Pressure Switch 60032 to 60032-1. DIR 18-55: Changed Air Inlet Temp Sensor part number from 61024 to 123449 in Appendix F, G and H. (Reference PIR 1542) DIR-19-04: Added additional requirements to Section 1.2: Emergency Shutdown. DIR 19-19: Expanded instructions for long-term shutdown (Section 4.10).</p>	Chris Blair