

AT MAXIMUM BTU/HR INPUT,
 MAINTAIN MINIMUM
 GAS PRESSURE AT 4.0" W.C.
 MAX. GAS PRESSURE=14" W.C.

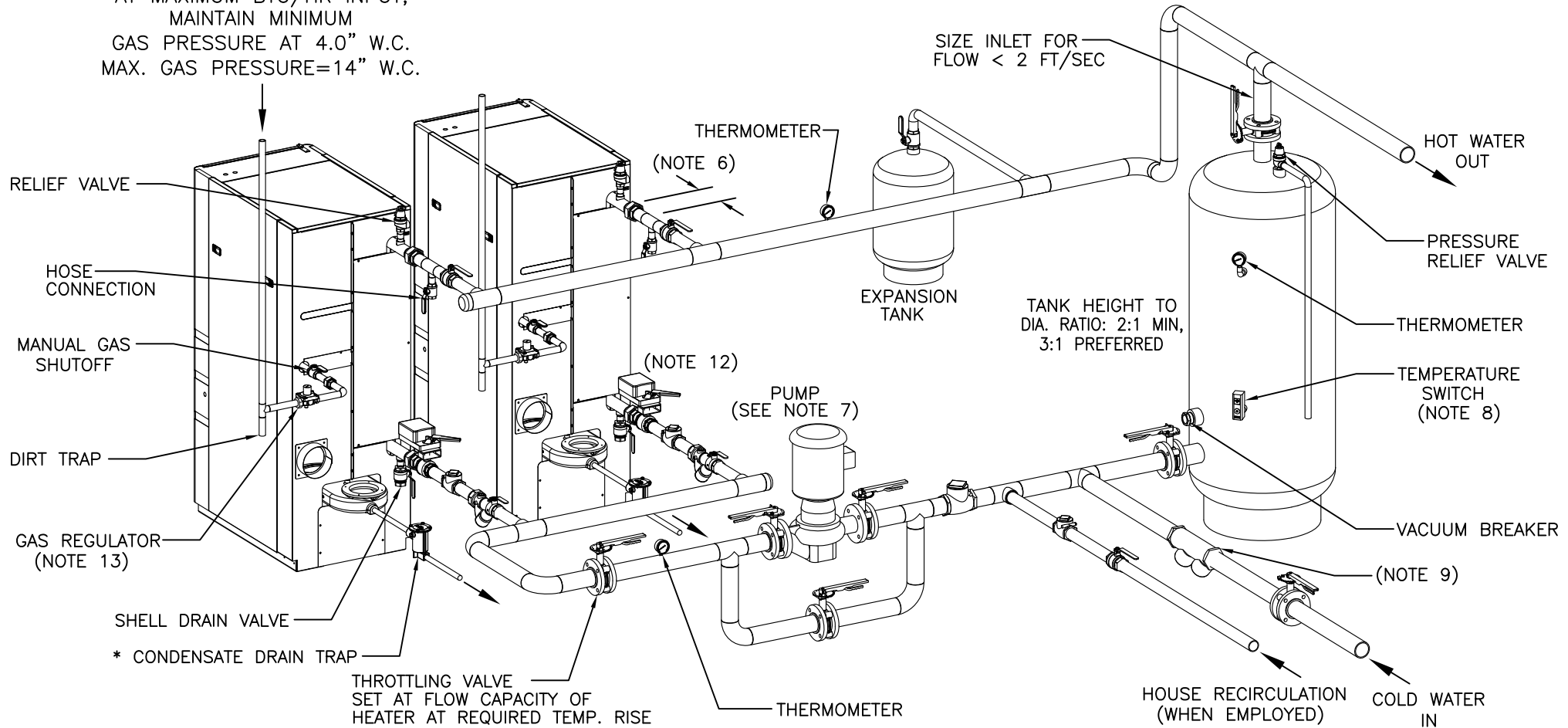

NOTES:

1. FOR ACTUAL SIZES AND LOCATIONS OF PIPING AND OTHER CONNECTIONS TO THE HEATER, SEE DIMENSIONAL DRAWING.
2. SHELL DRAIN VALVE AND CONDENSATE HOSE SHOULD BE ARRANGED TO PERMIT THE FLUIDS TO DRAIN FREELY, BY GRAVITY, TO A FLOOR DRAIN. RELIEF VALVE DISCHARGE SHOULD BE PIPED TO THE NEAREST FLOOR DRAIN. WHEN NO FLOOR DRAIN IS AVAILABLE, THE RELIEF VALVE DISCHARGE SHOULD BE PIPED VERTICALLY TO A HEIGHT OF AT LEAST 6" ABOVE THE FLOOR BUT NOT LESS THAN 2 PIPE DIAMETERS.
3. ALL (*) ITEMS ARE INCLUDED SEPARATELY IN SHIPMENT.
4. THIS IS A TYPICAL INSTALLATION DRAWING. LOCAL CODES AND AUTHORITIES SHOULD BE CONSULTED.
5. HOSE CONNECTION AT HEATER OUTLET IS FOR INITIAL HEATER CALIBRATION DURING START-UP.
6. LOCATE WATER INLET AND OUTLET FITTINGS (i.e. UNIONS, ELBOWS, ETC.) A MINIMUM OF 6" FROM WATER HEATER FITTINGS, TO PREVENT INTERFERENCE WITH REMOVAL OF HEATER PANELS.
7. PUMP SHOULD BE CAPABLE OF HEATER'S RATED FLOW AT DESIGN TEMPERATURE RISE.
8. MOUNT TEMPERATURE SWITCH 1/3 UP FROM THE BOTTOM OF THE TANK, SWITCH WILL TURN PUMP ON AND OFF.
9. IF PERMITTED BY LOCAL CODES, A CHECK VALVE MAY BE USED IN PLACE OF A BACKFLOW PREVENTER.
10. CONSULT LOCAL CODES FOR PROPER TYPE OF CONNECTIONS TO STORAGE TANK.
11. WHEN REQUIRED BY LOCAL CODES, A VACUUM BREAKER MUST BE INSTALLED WITH THE STORAGE TANK.
12. MOTORIZED/SEQUENCING VALVE WIRED INTO EACH UNIT'S INPUT/OUTPUT BOX CONNECT "AOUT" PER DRAWING SD-A-878.
13. AT 14" W.C. OR BELOW, A GAS REGULATOR IS OPTIONAL UNLESS REQUIRED BY LOCAL CODE.
14. STORAGE TANK MUST INCLUDE EITHER AN INLET DISPERSION TUBE OR INLET BAFFLE TO ENSURE STRATIFICATION.

 INTERNATIONAL, INC. <small>Blauvelt, NY 10913</small>	
INNOVATION GAS FIRED WATER HEATER TWO UNIT & STRAT. TANK INSTALLATION WITH SEQUENCING VALVES	
DWN. BY <u>K.S.</u> DATE <u>101912</u> SCALE <u>NTS</u> APPD. _____ DATE _____	SD-A-940 REV. B