

WILO IF-MODULE SBM
 (INSTALL INSIDE WILO PUMP
 IN ACCORDANCE TO IF-MODULE
 OPERATING INSTRUCTIONS)

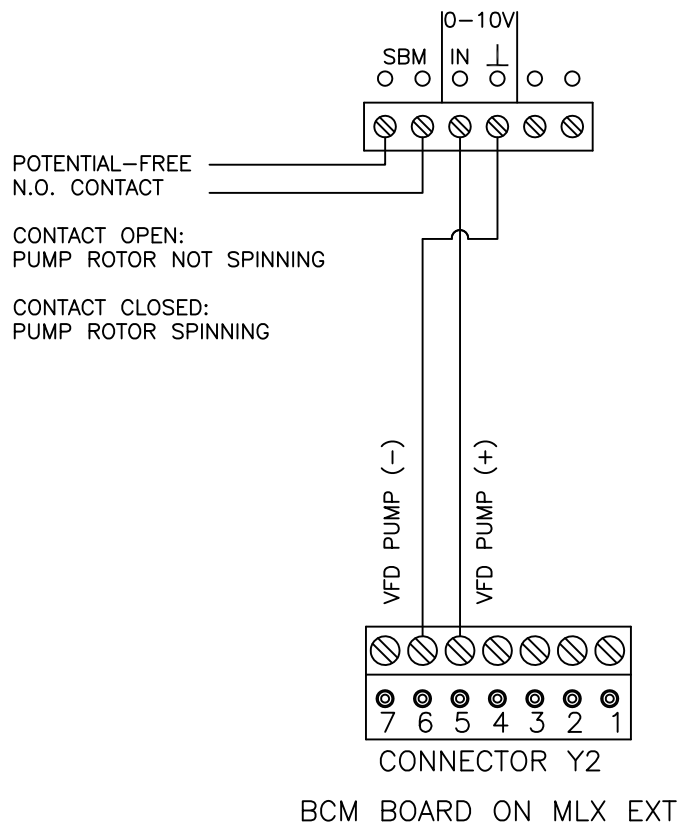

WILO PUMP - STRATOS

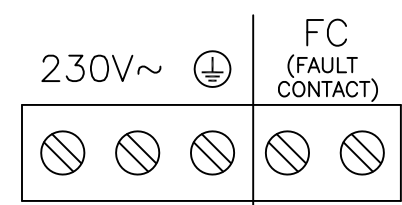

POWER SUPPLY:
 230VAC ±10%
 1PH
 60HZ

FAULT CONTACT:
 POTENTIAL-FREE
 CLOSED CONTACT

PERMISSIBLE CONTACT LOAD:
 MIN: 12VDC, 10mA
 MAX: 250VAC, 1A

- NOTES:
- 1) PUMP POWER SUPPLY SHALL BE SUPPLIED EXTERNALLY.
 - 2) SEE INSTRUCTIONS INCLUDED WITH WILO PUMP AND IF-MODULE FOR DETAILS.
 - 3) SEE AERCO O&M GF-136C FOR BCM CONTROL OF VFD PRIMARY PUMP.

AERCO INTERNATIONAL, INC.
 Blauvelt, NY 10913

MLX EXT - WILO PUMP
 POWER/0-10V WIRING DIAGRAM

DWN.BY CZ DATE 060314
 SCALE NTS
 APPD. _____ DATE _____

SD-A-1024

REV.
 A