

Operation & Maintenance Manual

AM Series Pool Heater

Natural Gas and Propane Gas Modulating Condensing Pool Heating System

- AM 399P
- AM 500P
- AM 750P
- AM 1000P



Other documents for this product include:

- TAG-0072 GF-146-E Electrical Power Guide
- TAG-0073 GF-146-G Gas Supply Guide
- TAG-0074 GF-146-P Piping Application Guide
- TAG-0075 GF-146-V Venting Guide

IMPORTANT!

This manual **MUST** be used in conjunction with User Manual GF-146 for the startup, operation, and maintenance of the AM Series Boiler used in the pool heating system.

Disclaimer

The information contained in this manual is subject to change without notice from AERCO International, Inc. AERCO makes no warranty of any kind with respect to this material, including, but not limited to, implied warranties of merchantability and fitness for a particular application. AERCO International is not liable for errors appearing in this manual, not for incidental or consequential damages occurring in connection with the furnishing, performance, or use of these materials

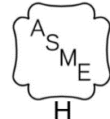

Heat | Hot Water | Energy Recovery Solutions

Table of Contents

FOREWORD	4
SECTION 1: GENERAL INFORMATION.....	5
1.1 WARNINGS & CAUTIONS.....	5
1.2 EMERGENCY SHUTDOWN	8
SECTION 2: FUNCTION & SPECIFICATIONS	9
2.1 INTRODUCTION.....	9
2.2 SPECIFICATIONS.....	10
2.2.1 Boiler - Burner Modules, Efficiency, Flow Rate, and Water Connections	10
2.2.2 Boiler - Exhaust Manifold, Condensate Trap, and Condensate Neutralizer	10
2.2.3 AM Pool Heater Supply and Return Piping Dimensions	10
2.3 BOILER CONTROLS	13
2.3.1 Temperature Control Modes.....	13
2.4 CONTROLS INTEROPERABILITY	14
SECTION 3: INSTALLATION – SITE.....	16
3.1 CHOOSING THE INSTALLATION LOCATION.....	16
3.2 BOILER AND WATER HEATER INSTALLATION LOCATION FACTORS.....	17
3.3 SAFETY CONCERNS	17
3.4 CLOSET AND ALCOVE INSTALLATION	17
3.5 CLEARANCES FOR INSTALLATION AND SERVICING	17
3.6 CLEARANCES TO COMBUSTIBLE MATERIAL	19
3.7 TRANSPORTING THE AM SERIES POOL HEATER	19
SECTION 4: INSTALLATION – VENT AND AIR	22
4.1 VENT AND COMBUSTION AIR PIPING.....	22
4.2 PREVENTION OF COMBUSTION AIR CONTAMINATION	22
SECTION 5: INSTALLATION – PIPING.....	24
5.1 BOILER WATER INLET AND OUTLET PIPING	24
5.2 WATER QUALITY	24
5.3 SYSTEM PIPING METHODS.....	24
5.4 FREEZE PROTECTION.....	25
5.5 SAFETY RELIEF VALVE	26
5.6 CONDENSATE DISPOSAL.....	27
5.7 POOL WATER PIPING REQUIREMENTS	28
5.8 POOL WATER CONNECTIONS TO THE HEAT EXCHANGER	28
5.9 PIPING METHODS - FULL FLOW OR BYPASS FLOW.....	29
5.9.1 Full Flow Piping Method.....	29
5.9.2 Bypass Flow Piping Method.....	30
SECTION 6: INSTALLATION – NATURAL GAS	32
6.1 GAS SUPPLY PIPING.....	32
6.2 NATURAL GAS PRESSURE REQUIREMENTS	32
6.3 CONNECTION OF GAS SUPPLY PIPING	33
6.4 NATURAL GAS PIPE SIZING	34
6.5 NATURAL GAS SUPPLY PRESSURE REQUIREMENTS	34
6.6 PROPANE GAS PIPE SIZING	34
6.7 PROPANE GAS SUPPLY PRESSURE REQUIREMENTS	34
6.8 CHECKING AND ADJUSTING THE UNIT INLET GAS SUPPLY PRESSURE.....	35
6.9 HIGH ALTITUDE OPERATION	35
6.10 CONVERSION FROM NATURAL GAS TO PROPANE GAS.....	35
6.10.1 Gas Conversion Kit.....	35

6.10.2 Gas Conversion Instructions35

SECTION 7: INSTALLATION - ELECTRICAL 36

7.1 ELECTRICAL CONNECTIONS – BOILER 36

 7.1.1 Power Supply Cable Connection.....36

 7.1.2 Connecting Units in Cascade.....38

 7.1.3 0-10 VDC Input Connections38

 7.1.4 MODBUS Interface Connections – Boilers and Water Heaters38

7.2 ELECTRICAL CONNECTIONS – BOILERS ONLY39

 7.2.1 Pool Flow Switch Connections.....39

 7.2.2 Pool Water High Limit Switch Connections40

SECTION 8: UNIT STARTUP..... 40

SECTION 9: OPERATION..... 40

SECTION 10: BOILER MAINTENANCE 40

SECTION 11: BOILER TECHNICAL DATA..... 41

SECTION 12: BOILER PARTS DRAWINGS & LISTS..... 41

SECTION 13: SYSTEM PART DRAWINGS AND LISTS 42

13.1 AM 399P/500P POOL HEATING SYSTEM PARTS DRAWING AND LIST.....42

13.2 AM 750P/1000P POOL HEATING SYSTEM PARTS DRAWING AND LIST.....44

AM SERIES POOL HEATER WARRANTY: 46

FOREWORD

The Advanced Modular (AM) Series Pool Heating system represents the latest in high efficiency pool heating applications. The AM Series Pool Heaters are comprised of an AERCO AM Series boiler, shell and tube heat exchanger, pump, expansion tank, air vent, and fittings for makeup water connections, all factory configured and installed on a skid. The AM Series boiler used in these systems features a unique modular design that provides exceptional reliability, serviceability, and fuel savings from 399 to 1000 MBTU. Each boiler is comprised of between two and four independent thermal modules firing up to 250 MBTU, and as low as 50 MBTU. This allows for superior temperature control and low-cycling operation. High efficiencies and low vent temperatures mean the unit can be vented in PVC, CPVC, Polypropylene, and AL29-4C vent materials. The front-access design of the boiler also means the unit is very simple to maintain and service.

AM Series Boiler Features:

- High Efficiency Condensing Boiler
- Natural Gas or Propane
- Superior Turndown 8:1 to 20:1 (depending on unit)
- Low NOx Emission <20ppm
- Direct or Conventional Vent with PVC, CPVC, Polypropylene, or AL29-4C materials
- Concentric Vent Capability
- Common Vent Capability
- Side wall common venting with no additional check valve
- Small, Doorway-Size Footprint
- Superior Reliability
- Minimal Maintenance
- Easy Front Access for Serviceability
- Zero Side Clearance
- Supports Integration to BAS System
- Modbus Communication Standard
- Integrated isolation valves, flow meters, and condensate neutralizer

AM Series Pool Heater Features:

- **Circulation pump:** the pump circulates water through the piping loop, as well as the boiler and heat exchanger.
- **Low Water Cut-Off:** An LWCO is provided to prevent boiler operation in case of insufficient boiler water flow.
- **Expansion tank:** A rugged diaphragm type expansion tank protects the boiler water piping loop from excessive pressure and keep the pressure below relief valve setting.
- **Air vent:** The boiler is provided with an air vent to automatically purge the unwanted air in the closed boiler water loop.
- **Makeup water connections:** Connections are provided for the inlet of makeup water to the boiler water loop for fast fill and to contain the pressure reducing fill valve, as well as the shutoff valve.
- **Factory Configuration:** All components are piped together and secured to a carbon steel support base for ease of handling and installation.

SECTION 1: GENERAL INFORMATION

1.1 Warnings & Cautions

NOTE:

This manual provides installation instructions for the AM Series Pool Heaters, but does NOT provide information for venting, system start-up, operation, or maintenance of the boiler used in the system. The AM Series User Manual, GF-146, is required for that information, and the reader will be referred to the necessary sections in that document when necessary.

In addition to all the requirements included in this AERCO Instruction Manual, the installation of units MUST conform with local building codes, or, in the absence of local codes, ANSI Z223.1 (National Fuel Gas Code Publication No. NFPA-54) for gas-fired boilers and ANSI/NFPA58 for LP gas-fired boilers. Where applicable, the equipment shall be installed in accordance with the current Installation Code for Gas Burning Appliances and Equipment, CSA B149.1, and applicable Provincial regulations for the class; which should be carefully followed in all cases. Authorities having jurisdiction should be consulted before installations are made.

IMPORTANT!

This Instruction Manual is an integral part of the product and must be maintained in legible condition. It must be given to the user by the installer and kept in a safe place for future reference.

WARNING!

Failure to comply with provisions, warnings, and cautions provided in this manual can lead to extensive property damage and/or personal injury or death.

In the event of a breakdown and/or malfunction of the boiler used in this system, turn off the unit and do not make any attempt to repair it. The boiler must be serviced exclusively by a Qualified installer using original spare parts. Failure to comply with this requirement may compromise the safety of the unit.

WARNING!

Installer: Read all instructions including this manual, before installing. Perform steps in the order given.

User: The installation and maintenance sections of this manual are for use only by a qualified heating installer. Refer to Chapter 9: Operation for user information.

Installation and Alterations: Only a Qualified installer must carry out the installation and calibration of the boiler. Never modify the boiler or its components in any way.

Overheating: Should overheating occur or the gas supply fail, turn off the manual gas shut-off valve external to the appliance. Do NOT turn off or disconnect the electrical supply to the circulator.

Water Contamination: Do not use this appliance if any part has been under water. Immediately call a licensed authorized technician to inspect the appliance and to replace any part of the control system and any gas control, which has been under water. Ensure the boiler and its controls are protected from dripping or spraying water during normal operation or service.

Spare Parts: Only use the boiler with the accessories and spares listed in this manual. Failure to do so can cause equipment damage or dangerous conditions.

NOTE:

When calling or writing about the AM Series Pool Heating system, have the unit model and serial number as seen on the unit rating plate located on the boiler.

CAUTION!

Do not use petroleum-based cleaning or sealing compounds in the boiler system. Gaskets and seals in the system may be damaged. This can result in substantial property damage.

The manufacturer declines all liability, contractual or otherwise (warranty included), for any damage to people, animals property or this same appliance, caused by:

- Incorrect installation or failure to comply with this or any other instruction provided by the manufacturer;
- Failure to comply with the applicable local and/or national regulations in force.
- Incorrect use of this appliance.
- Inadequate or incorrect service
- Inadequate or incorrect maintenance.

FOR YOUR SAFETY READ BEFORE OPERATING

WARNING: If you do not follow these instructions exactly, a fire or explosion may result causing property damage, personal injury or loss of life.

- A. This appliance does not have a pilot. It is equipped with an ignition device which automatically lights the burner. Do not try to light the burner by hand.
 - If you cannot reach your gas supplier, call the fire department.
 - B. BEFORE OPERATING smell all around the appliance area for gas. Be sure to smell next to the floor because some gas is heavier than air and will settle on the floor.
 - C. Use only your hand to push in or turn the gas control knob. Never use tools. If the knob will not push in or turn by hand, don't try to repair it, call a qualified service technician. Force or attempted repair may result in a fire or explosion.
 - D. Do not use this appliance if any part has been under water. Immediately call a qualified service technician to inspect the appliance and to replace any part of the control system and any gas control which has been under water.
- WHAT TO DO IF YOU SMELL GAS**
- Do not try to light any appliance.
 - Do not touch any electric switch;
 - Do not use any phone in your building.
 - Immediately call your gas supplier from a neighbor's phone. Follow the gas supplier's instructions.

OPERATING INSTRUCTIONS

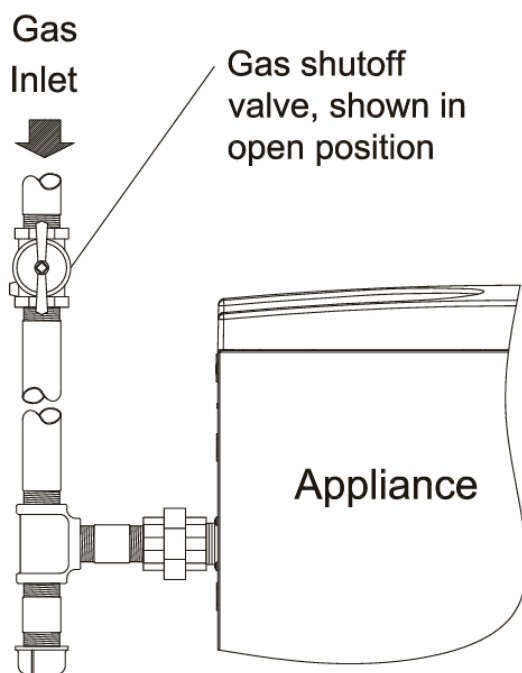

1. STOP! Read the safety information above (to the left) on this label.
2. Turn off all electric power to the appliance.
3. Set the main switch to **OFF**.
4. This appliance is equipped with an ignition device which automatically lights the burner. Do not try to light the burner by hand.
5. Close the manual gas shutoff valve turning the knob clockwise . Do not force.
6. Wait five (5) minutes to clear out any gas. Then smell for gas, including near the floor. If you smell gas, STOP! Follow "B" in the safety information above (to the left) on this label. If you don't smell gas, go to the next step.
7. Open the manual gas shutoff valve turning the knob counterclockwise .
8. Turn on all electric power to the appliance, and set the main switch to the on position.
9. Set an heating request following the installation manual.
10. If the appliance will not operate, follow the instructions "To Turn Off Gas To Appliance" and call your service technician or gas supplier.

TO TURN OFF GAS TO APPLIANCE

1. Turn off all electric power to the appliance if service is to be performed.
 - 2. Set the main switch to **OFF**.
 - 3. Close the manual gas shutoff valve turning the knob clockwise . Do not force.

62408200

1.2 Emergency Shutdown

If overheating occurs or the gas supply fails to shut off, close the manual gas shutoff valve (Figure 1-1) located external to the unit.

NOTE:

The Installer must identify and indicate the location of the emergency shutdown manual gas valve to operating personnel.

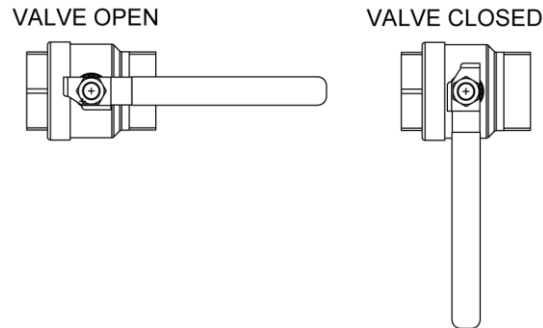

Figure 1-1: Manual Gas Shutoff Valve

IMPORTANT! FOR MASSACHUSETTS INSTALLATIONS:

Boiler Installations within the Commonwealth of Massachusetts must conform to the following requirements:

- Boiler must be installed by a plumber or a gas fitter who is licensed within the Commonwealth of Massachusetts.
- Prior to unit operation, the complete gas train and all connections must be leak tested using a non-corrosive soap.
- The vent termination must be located a minimum of 4 feet above grade level. If side-wall venting is used, the installation must conform to the requirements in **248 CMR 5.08 (2)**.
- Must be installed according to all local codes.

SECTION 2: FUNCTION & SPECIFICATIONS

2.1 INTRODUCTION

REFERENCE NOTE:

This manual provides installation instructions for the AM Series Pool Heaters, but not documentation for all features, such as venting, start-up, operation, or maintenance of the boiler used in the system. For that information, refer to the AM Series User Manual, GF-146.

Figure 2-1 shows the exterior appearance of an AM Series Pool heating system as it comes factory configured and installed on a skid. The AM Series Pool Heater comes in four functionally sized models; the 399, 500, 750, and 1000. Figure 2-2 shows the boilers available.

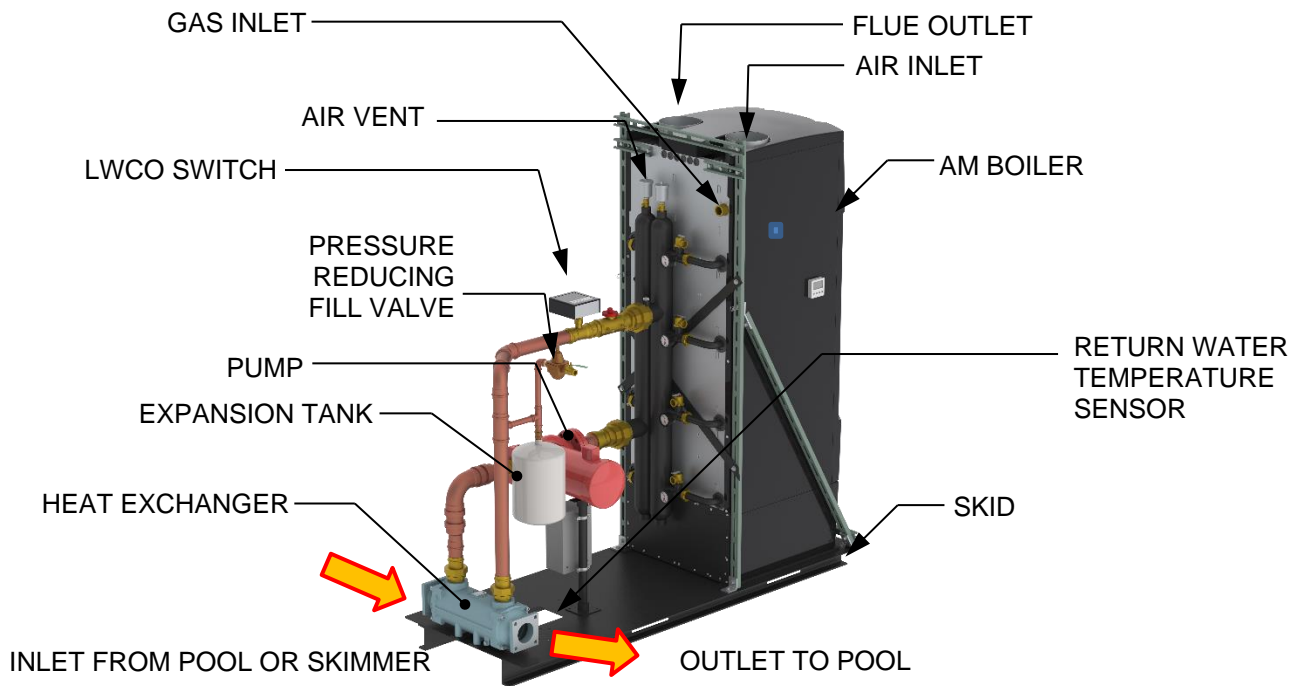

Figure 2-1: AM Series Pool Heating System (AM 750P / 1000P Shown)

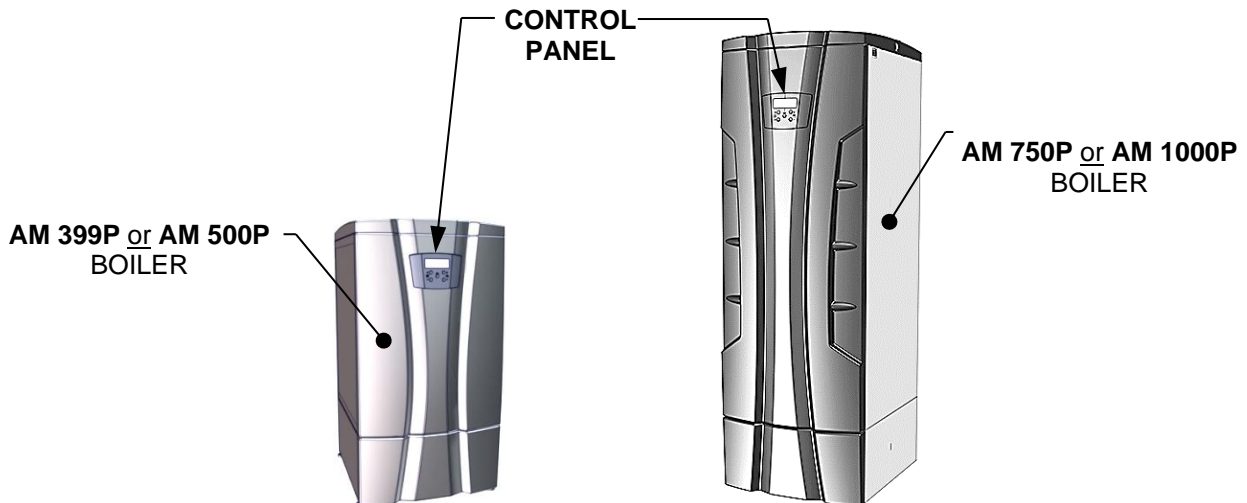

Figure 2-2: Boiler Models Used in AM Series Pool Heating Systems

2.2 Specifications

2.2.1 Boiler - Burner Modules, Efficiency, Flow Rate, and Water Connections

Each AM Series pool heating system includes a boiler featuring from 2 to 4 thermal modules, depending on model, performing total turn down ratios without loss of combustion efficiency as shown in the table below. Each thermal module's premix burner is a metal fiber mesh covering a stainless steel head, with spark ignition and flame rectification. All burner materials exposed to the combustion zone are of stainless steel construction. There are no moving parts within the burner itself. The burners produce <20 ppm of NOx corrected to 3% excess oxygen. A modulating gas valve, and variable speed fan, meter the natural gas and air input, respectively.

Each module has a dedicated isolation valve on the inlet side of the module on the rear of the unit. The table below shows the pool flow rates for each model, as well as the water connection sizes.

AM Series Pool Heating System General Specifications				
Model	# Modules	Turndown Ratio	Pool Water Maximum Flowrate	Connection Pool Side
AM 399P	2	8:1	127 GPM	3 inches NPT
AM 500P	2	10:1	127 GPM	3 inches NPT
AM 750P	3	15:1	222 GPM	3 inches Flg ANSI 150
AM 1000P	4	20:1	222 GPM	3 inches Flg ANSI 150

2.2.2 Boiler - Exhaust Manifold, Condensate Trap, and Condensate Neutralizer

NOTE:

Refer to Section 5.6 of this document for detailed information concerning the condensate trap and neutralizer tank installation and maintenance.

2.2.3 AM Pool Heater Supply and Return Piping Dimensions

Connections and dimensions for AM Series pool heaters are shown in Figure 2-3a and 2-3b over the following pages.

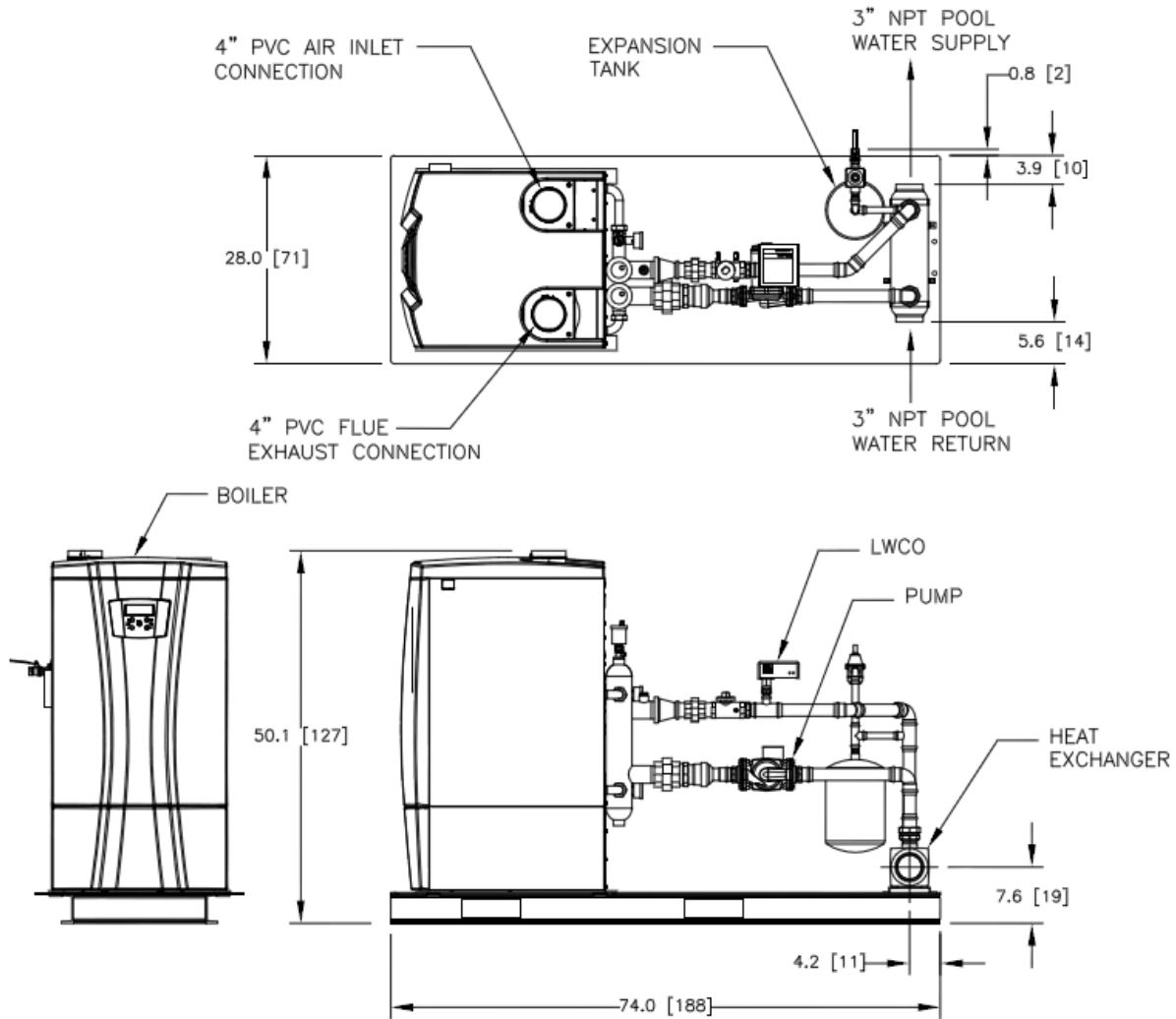

Figure 2-3a: AM 399P/500P Pool Heater Connection Dimensions

NOTE:

These drawings and/or dimensions are subject to change. Please refer to latest drawings revisions on the AERCO website.

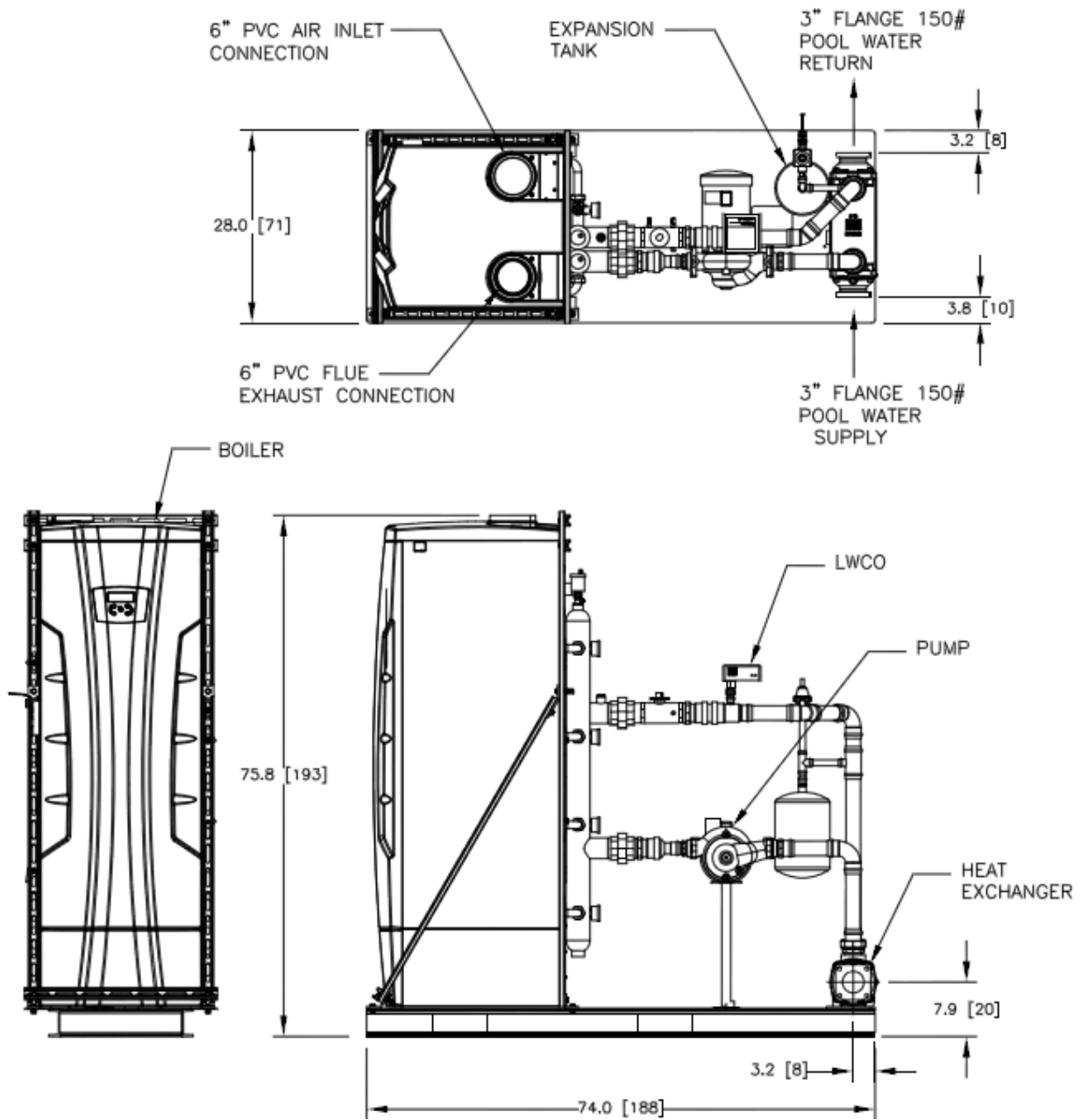

Figure 2-3b: AM 750P/1000P Pool Heater Connection Dimensions

NOTE:

These drawings and/or dimensions are subject to change. Please refer to latest drawings revisions on the AERCO website.

2.3 Boiler Controls

AM Series pool heater units must be controlled in one of two ways: either through an external AERCO controller, or be controlled through a Building Automation System (BAS). The boiler is comprised of an internal controller coordinating individual thermal module controllers linked as slaves, and these controls are fully field adjustable while the boiler is in operation by either the external controller or the BAS. The boiler features an LCD display for monitoring of all sensors and interlocks. Each of the thermal module controllers consists of a combustion safeguard and flame monitoring system. Individual thermal module controllers are field replaceable. The combustion safeguard/flame monitoring system utilizes spark ignition and a rectification type flame sensor. The boiler control system reports and displays boiler & sensor status and includes extensive self-diagnostic capabilities.

Each boiler incorporates dual over-temperature protection with manual reset and low water cut out, both in accordance with ASME Section IV and CSD-1.

2.3.1 Temperature Control Modes

During boiler operation, the individual thermal module controllers vary their respective thermal module's input throughout its full range to maximize the condensing capability of the boiler, and operates with an Inverse Efficiency Curve, with known Part Load Value Efficiencies. There are five (5) modes in which the AM boiler may be set, each one adjusting this performance according to specific requirements.

The AM Series boiler(s) operates in the control modes listed below:

- Internal Setpoint
- Indoor/Outdoor Reset
- 0 to 10VDC Temperature Setpoint
- Network Temperature Setpoint

A description of each selectable control mode follows:

- **Internal Setpoint:**

In this mode, the control of discharge water temperature is set through an internal setpoint with an adjustment of between 68°F to 189°F. The individual thermal module controllers vary their respective thermal module's input throughout its full range to maximize the condensing capability of the water heater. The boiler operates to maintain a constant pool water temperature.

- **Indoor/Outdoor Reset:**

In this mode, the boiler operates to vary pool water temperature setpoint on an inverse ratio in response to *outdoor* temperature (measured by an external temperature sensor) to control pool water temperature. The individual thermal module controllers vary their respective thermal module's input throughout its full range to maximize the condensing capability of the boiler.

- **0VDC to 10VDC Temperature Setpoint:**

In this mode, the boiler operates to vary pool water temperature setpoint linearly as an externally applied 0 VDC to 10 VDC signal is supplied to the E8 Controller.

- **Network Temperature Setpoint:**

In this mode, the boiler will operate to vary pool heater temperature setpoint as an external communication utilizing the MODBUS protocol is supplied to the boiler's communications module via the RS-485 port.

2.4 Controls Interoperability

The communications module utilizes the MODBUS open protocol to interface with third party Building Automation Systems (BAS).

The controls interface with BACnet, Lonworks, and N2, shall utilize an optional AERCO Communications Gateway to act as a MODBUS interface/translator between the BAS the communications. The AERCO Communications Gateway is comprised of a microprocessor based control utilizing the MODBUS protocol to communicate with the boilers. Non-volatile backup of all point mappings and programs are internally provided as standard. Connection between Gateway and individual boilers shall be “daisy chain” with shielded, twisted-pair, and low voltage wiring for ease of installation.

(This Page Is Intentionally Blank)

SECTION 3: INSTALLATION – SITE

3.1 Choosing the Installation Location

This section describes the general installation considerations for the AM Series Pool Heaters.

WARNING!

Provisions for combustion air and ventilation of the boiler room are always required, regardless whether the combustion air is taken from the outside (Direct Vent, sealed combustion) or inside (room air for combustion). Insufficient ventilation of the boiler room can lead to high air temperatures. Make sure that intake and exhaust openings are sufficiently sized and no reduction or closure of openings takes place. If these are not provided, do not operate the boiler.

WARNING!

LIQUEFIED PETROLEUM (L.P.) PROPANE GAS-FIRED BOILER LOCATION REQUIRES SPECIAL ATTENTION: 1994 UNIFORM MECHANICAL CODE, section 304.6: “LPG Appliances. Liquefied petroleum gas-burning appliances shall not be installed in a pit, basement or similar location where heavier-than-air-gas might collect. Appliances so fueled shall not be installed in an above grade under-floor space or basement unless such location is provided with an approved means for removal of unburned gas.”

This appliance is not designed for direct outdoor installation. If installed outside of the structure, it must be sheltered so it is protected from rain, wind, sun and frost. NEVER place this appliance in a location that would subject it to temperatures at or near freezing or excessively high temperature. Failure to properly locate this unit can result in premature failure.

The boiler must NOT be installed on carpeting.

This appliance must be installed in a location so that any water leaking from the unit or piping connections or relief valve openings will not cause damage to the area surrounding the unit or any lower floors in the structure. When such locations cannot be avoided, it is recommended that a suitable drain pan, adequately drained, be installed under the boiler. The pan must not restrict combustion air flow.

When installed in a room with thin flooring, resonating noises may occur. Install noise reducing parts if required.

Do not allow excessive dust to collect on the appliance.

WARNING!

Do not store or use gasoline or other flammable vapors or liquids in the vicinity of this or any other appliance.

WHAT TO DO IF YOU SMELL GAS:

- Do not try to light any appliance.
- Do not touch any electrical switch.
- Do not use any phone in the building.
- Immediately call your gas supplier from a neighbor's phone. Follow the gas supplier's instructions.
- If you cannot contact your gas supplier, call the fire department.

3.2 Boiler and Water Heater Installation Location Factors

When locating the boiler or water heater, the following factors must be considered:

- location of vent/air intakes;
- connection to the gas supply;
- connection to the water supply;
- connection to the pool system;
- connection to the electrical supply;
- disposal of the condensation produced by the boiler;
- connection to the room thermostat, building automation system, or equivalent device;
- piping of the safety relief valve discharge;
- connection of the outdoor temperature sensor;
- If flooding is possible, elevate the boiler sufficiently to prevent water from reaching the unit;

3.3 Safety Concerns

WARNING!

Do not store any flammable materials or liquids in the immediate vicinity of the boiler.

3.4 Closet and Alcove Installation

This heater is approved for the installation in an alcove or closet, within compliance of the guidelines pertaining to clearance, venting and ventilation openings as per this manual and the National Fuel Gas Code, ANSI Z223.1/NFPA 54 and/or CAN/CSA B149.1, Natural Gas and Propane Installation Code.

WARNING!

Do not use PVC/CPVS/Polypropylene exhaust pipe material into a closet or alcove. The only exhaust pipe material accepted is stainless steel. Failure to follow this warning can result in excessive levels of carbon monoxide or a fire, which can cause severe personal injury or death.

3.5 Clearances for Installation and Servicing

The following are the minimum clearances required for installation and servicing of an AM Series pool heater. See also Figures 3-1a and 3-1b.

- 32 inches from front of boiler.
- 24 inches on both left and right sides.
- 12 inches from rear of skid or per piping configuration of the heat exchanger.

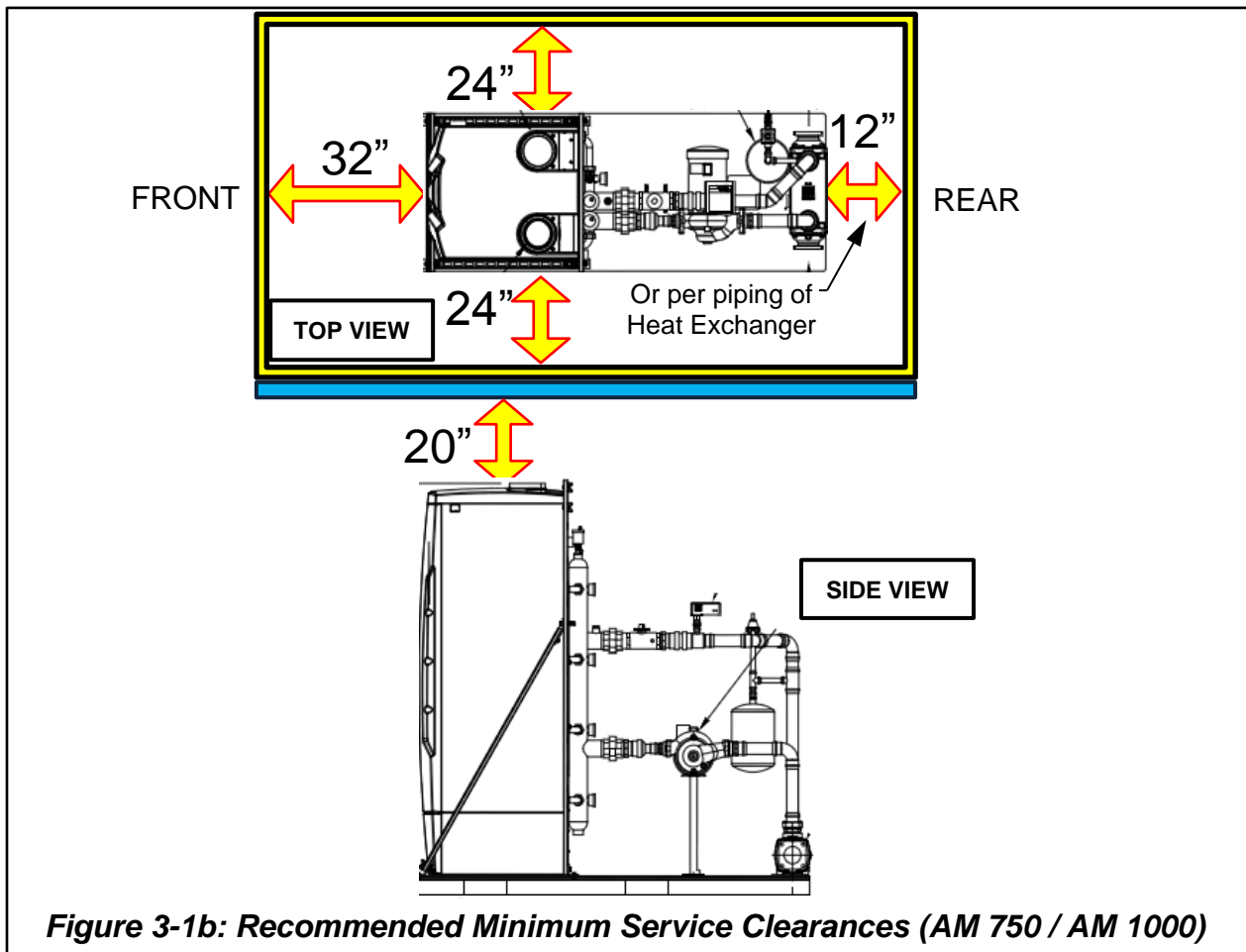
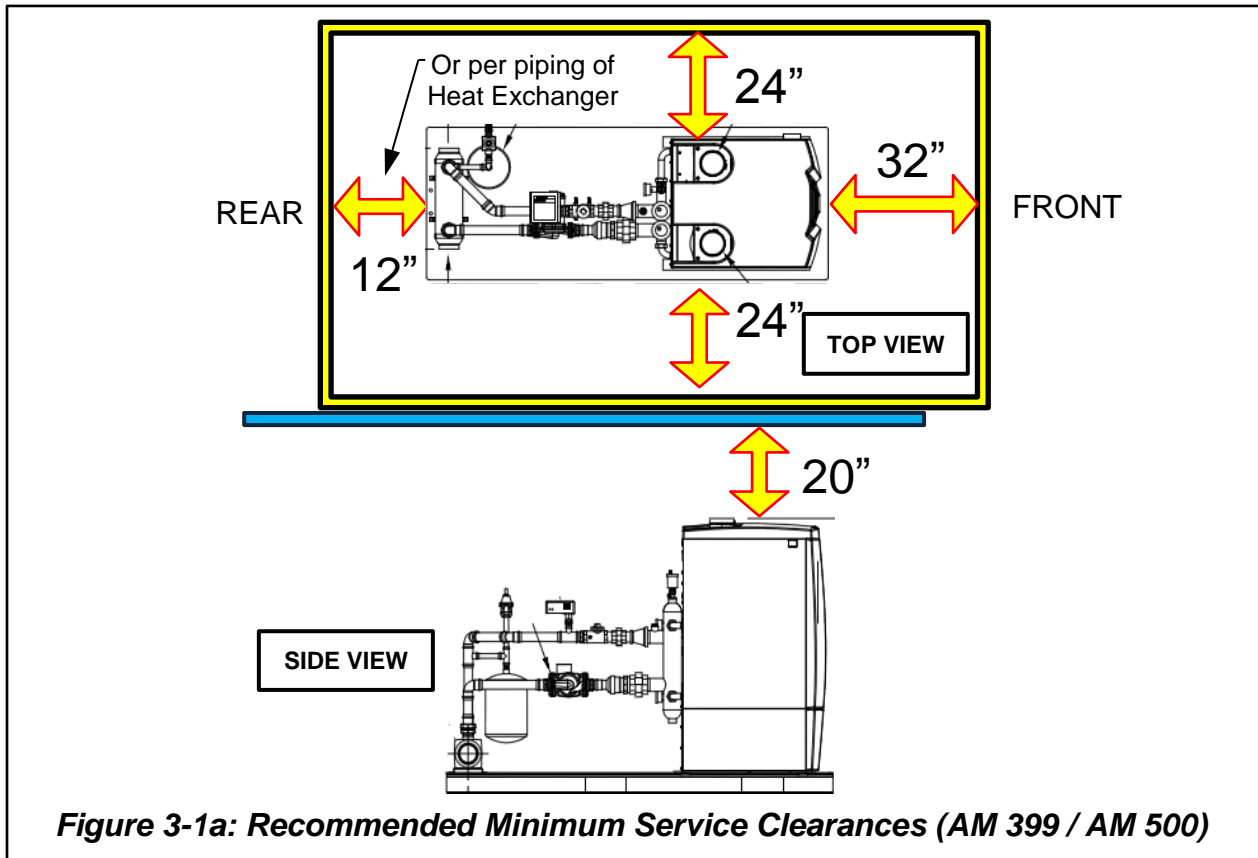

NOTE:

Service clearances are minimum required clearances for ease of access, but larger service clearances are always preferred.

3.6 Clearances to Combustible Material

This unit may be installed directly onto a floor of combustible material with the following clearances:

Table 3-1: Unit Installation Clearance Dimensions	
Component	Clearance Distance
Ceiling	2 inches (51 mm)
Front	2 inches (51 mm)
Rear	2 inches (51 mm)
Sides	2 inches (51 mm)
Floor	0 inches (0 mm)
Concentric vent	0 inches (0 mm)
Split vent (two pipes) first 3 feet from the boiler	1 inch (25 mm)
Split vent (two pipes) after 3 feet from the boiler	0 inches (0 mm)
Boiler piping	¼ inch (7 mm)

WARNING!

All aspects of installation of the Pool Heater Plant must be in strict accordance with manufacturer's instructions. The vent system *must conform to* all manufacturer's recommendations and shall utilize UL listed stainless steel AL-29-4C, Polypropylene, PVC, or CPVC Positive Pressure venting materials. The vent must be sized in accordance with AERCO's recommendations.

3.7 Transporting the AM Series Pool Heater

After removing the shipping carton from the unit, ensure the following when transporting the unit to the installation location.

- Only transport the unit using the right transportation equipment, such as a hand truck with a fastening belt.
- During transportation, the unit must be secured on the transportation equipment to prevent it from falling off.
- Protect all parts against impacts during transport.
- Observe the transportation markings on the packaging.
- Leave the protective covers on the connections until ready to install.
- During transportation, cover the flue gas and air intake connections at the top of the unit with plastic or other material to avoid contamination.

CAUTION!

The AERCO AM pool Heater must be moved **ONLY** with a forklift through the supporting skid, as shown in Figure 3-2.

Transporting an AM Series Pool Heating System

1. Remove the two (2) 3/8-16 hex cap screws, washers, and nuts attaching the front of the assembly skid to the wooden pallet, and then remove the same hardware at the rear of the unit.
2. Once the assembly is disconnected from the pallet, transport using a fork lift inserted into the skid, at front (green arrows); or at the sides (yellow arrows), as indicated by in Figure 3-2.

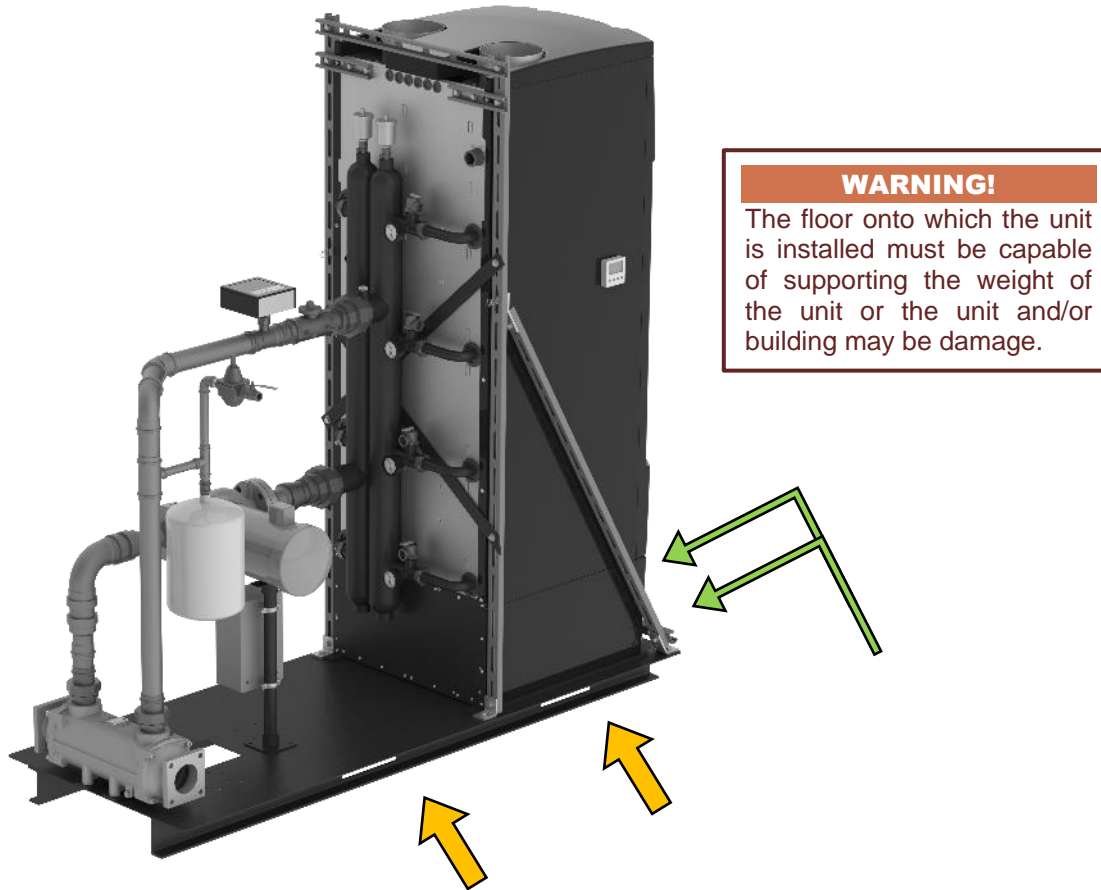

Figure 3-2: Transporting the AM Series Pool Heater

CAUTION!

DO NOT use the lifting lugs on the AM boiler itself to lift the entire AM assembly. They are to be used **ONLY** in the maintenance or replacement of the boiler unit.

Shipping Weights	
Model	Approx. Weight (lbs.)
AM 399P	920
AM 500P	930
AM 750P	1,205
AM 1000P	1,290

3. When in position, remove all wrapping to prepare for installation.

(This Page Is Intentionally Blank)

SECTION 4: INSTALLATION – VENT AND AIR

WARNING!

This section provides necessary, but only general, information and requirements regarding flue venting and combustion air piping installation for this system. The installer **must** refer to **Section 6** of the AM Series User Manual, **GF-146**, for very important information and instructions regarding the installation of the venting and combustion air piping, or risk creating a dangerous situation.

4.1 Vent and Combustion Air Piping

This boiler requires a special vent system, designed for pressurized venting.

The boiler is to be configured for either direct vent installation or for installation using room combustion air. When room combustion air is considered, see Chapter 6.

Vent and air may be vented vertically through the roof or out a side wall, unless otherwise specified. You may use any of the vent/air piping methods covered in Chapter 6.

Be sure to locate the unit such that the vent and air piping can be routed through the building and properly terminated.

The vent/air piping lengths, routing and termination method must all comply with the methods and limits given in Section 6 of the AM Series User Manual, GF-146.

4.2 Prevention of Combustion Air Contamination

Install air inlet piping for the appliance as described in Section 6 of the AM Series User Manual, GF-146. Do not terminate vent/air in locations that can allow contamination of combustion air.

WARNING!

Ensure that the combustion air will not contain any contaminants. Contaminated combustion air will damage the unit, resulting in possible personal injury, death or substantial property damage.

(This Page Is Intentionally Blank)

SECTION 5: INSTALLATION – PIPING

5.1 Boiler Water Inlet and Outlet Piping

When connecting the hot water outlet and cold water inlet to building piping, first make sure the threads are thoroughly clean. AERCO recommends using Loctite® 7649 to prime the threads and then Loctite 567 as pipe dope. **Do NOT use Teflon tape.**

5.2 Water Quality

- Before connecting the boiler to the heating system, the heating system must be thoroughly flushed to remove sediment, flux, filings and other foreign matter. The heat exchanger can be damaged by build-up of corrosion due to sediment.
- An approved inhibitor should be added to the heating system water to prevent limestone and magnetite deposits from forming and to protect the boiler from galvanic corrosion.
- The manufacturer cannot be held responsible for any damage caused by incorrect use of additives in the heating system.
- Continual fresh make-up water will reduce boiler life. Mineral buildup in the heat exchanger reduces heat transfer, overheats the stainless steel heat exchanger, and causes failure. Addition of oxygen carried in by makeup water can cause internal corrosion in system components. Leaks in boiler or piping must be repaired at once to prevent makeup water entering the boiler.
- Do not use the boiler to directly heat swimming pools or spa water.
- **Hardness** –Hardness substantially contributes to the formation of scaling, which is highly undesirable. The total hardness must be less than 200 ppm total dissolved solids (TDS).
- **Artificial Softness** – Do NOT use artificially softened water. Artificial softening agents generally use salt, which creates a chloride water chemistry, a major contributor to the corrosion of the types of metals used in hydronic systems. Elevated salt levels also contribute to higher conductivity levels, another undesirable characteristic in hydronic systems.
- **Chloride** – Chlorides are salts resulting from the combination of the gas chlorine with a metal and are instrumental in accelerating corrosion in the types of metals used in hydronic systems. Chlorides may be naturally occurring in the water. Concentrations of chlorides in system water should be less than 150 ppm.
- **Conductivity** – Dissolved metals and minerals increase the conductivity of water and indicate not only the presence of undesired corrosive agents, but also contribute to the transfer and migration of ions and charged particles in the water that contribute to fouling of sensors, valves, and other devices used in the system. Additionally, high conductivity contributes to galvanic corrosion, in which one metal will preferentially corrode when in when both are in contact with an electrolyte. Conductivity should be less than 3000 µS.
- **pH** – The pH must always be between 7.5 and 9.5.

5.3 System Piping Methods

This boiler is designed to function in a closed loop pressurized system not less than 15 psi (1 bar). A pressure gauge is included to monitor system pressure. The factory configuration of the pool heater features an air vent, which removes air from the system. Install the system so the gas ignition system components are protected from water (dripping, spraying, etc.), during appliance operation for basic service of circulator replacement, valves, and others.

5.4 Freeze Protection

Freeze protection for new or existing systems must use glycol that is specially formulated for this purpose. This includes inhibitors, which prevent the glycol from attacking the metallic system components. Make certain to check that the system fluid is correct for the glycol concentration and inhibitor level. The system should be tested at least once a year and as recommended by the producer of the glycol solution. Allowance should be made for the expansion of the glycol solution in the system piping. Use only inhibited propylene glycol solutions. Ethylene glycol is toxic and can corrode gaskets and seals.

WARNING!

Never use non-approved additives or toxic boiler treatment chemicals in the heating system. Any additives introduced into the heating system must be recognized as safe. Use only inhibited propylene glycol solutions, which are specifically formulated for hydronic systems. Ethylene glycol is toxic and can attack gaskets and seals used in hydronic systems.

CAUTION!

It is up to the installer to ensure that the minimum system flow is met, otherwise the flow sensors will automatically stop the burner.

WARNING!

The National Standard Plumbing Code, the National Plumbing Code of Canada and the Uniform Plumbing Code limit the pressure of the heat transfer fluid to less than the minimum working pressure of the potable water system up to 30 psi maximum. Also, the heat transfer fluid must be water or other non-toxic fluid having a toxicity of Class 1, as listed in Clinical Toxicology of Commercial Products, 5th Edition.

5.5 Safety Relief Valve

AM units come equipped with a safety relief valve on each factory installed module. Boilers are supplied with 50 PSI pressure relief valves. If a higher or lower rated PRV is required it must be field supplied and installed.

Pipe the discharge of the safety relief valve(s) (Figure 5-1) to a suitable drain to prevent injury in the event of pressure relief. Each relief valve must have its own discharge piping, be piped to within 12” of the ground, and not be combined with any other piping all the way to the point of discharge into a drain. Provide piping that is the same size as the safety relief valve outlet.

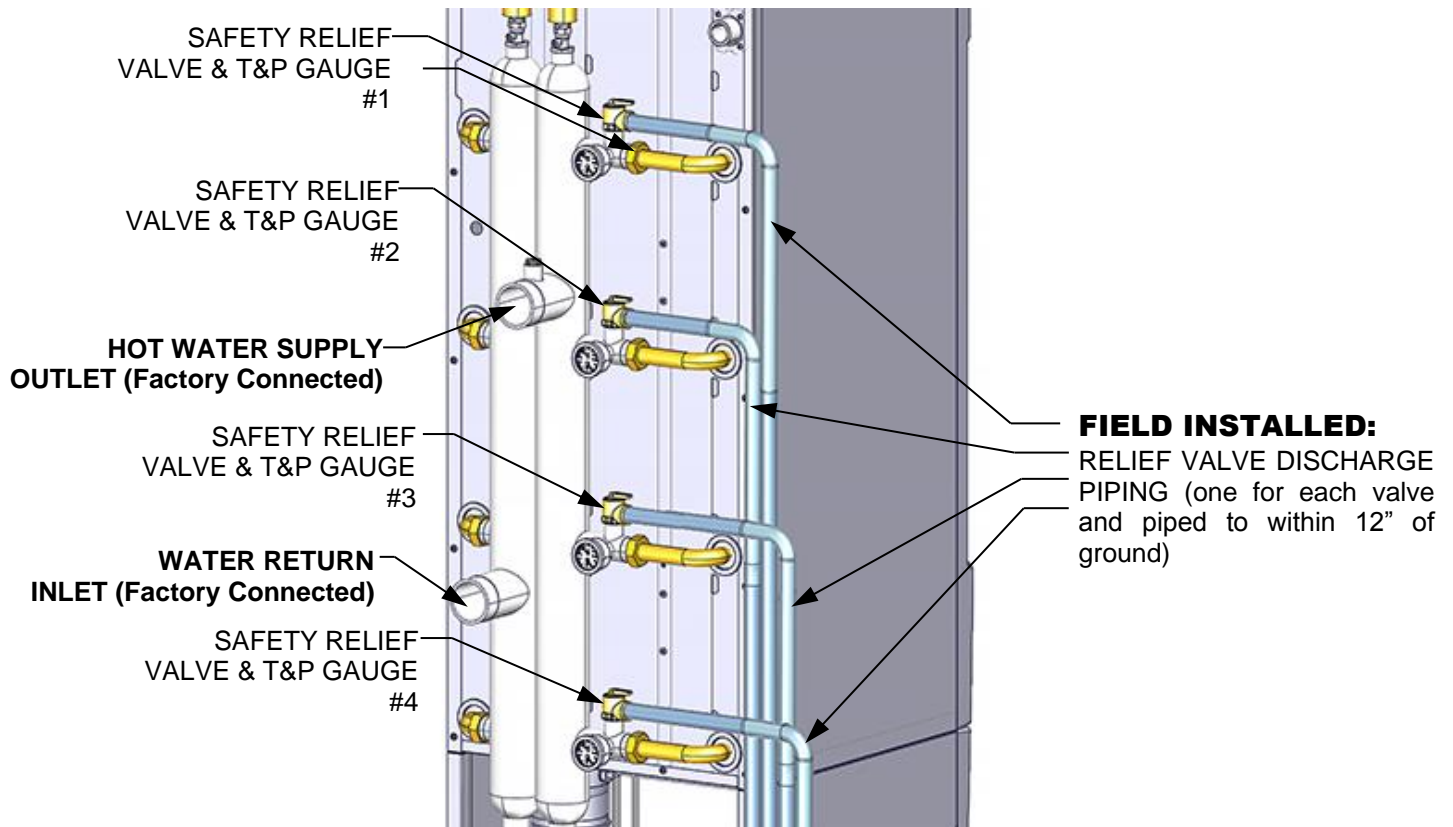

Figure 5-1: Discharge Piping for Boiler Relief Valves (AM 1000 Boiler Shown)

5.6 Condensate Disposal

WARNING!

The condensate trap (Fig. 5-2, item “B”) MUST be filled with water or combustion gases will enter the room. The condensate neutralizer tank must be installed into the unit exactly as shown in Figure 5-2. Do NOT remove the condensate neutralizer tank from its position while the unit is in operation, as this will result in dangerous carbon monoxide escaping and creating a very dangerous situation.

The unit is equipped with a condensate neutralizer tank for the evacuation of condensate and to prevent the leakage of combustion products. The condensate drains from the flue exhaust outlet “A” through pipe to condensate neutralizer tank, drains through pipe “C” (Figure 4-8) and “E” (Figure 4-9, and empties into the floor drain or drain pan, “F” (Figure 5-3).

NOTE:

In newer units, hose “A” (Fig. 5-2) attaches to a port at the bottom of flue, rather than the side.

The condensation disposal system must:

- slope the condensate tubing down and away from the boiler into a drain or drain pan (See Figure 4-9). Condensate from the boiler will be slightly acidic (around pH 4). The neutralizing tank (see Figure 5-2, item “B”) is built into the boiler and will neutralize the condensate products;
- be carried out with a pipe with an internal diameter equal to or greater than 3/4 inches (19 mm);
- be installed in such a way so as to avoid the freezing of the liquid;
- never discharge into gutters or rain collectors;
- be properly pitched towards the point of discharge avoiding high points, which could place the condensate system under pressure;

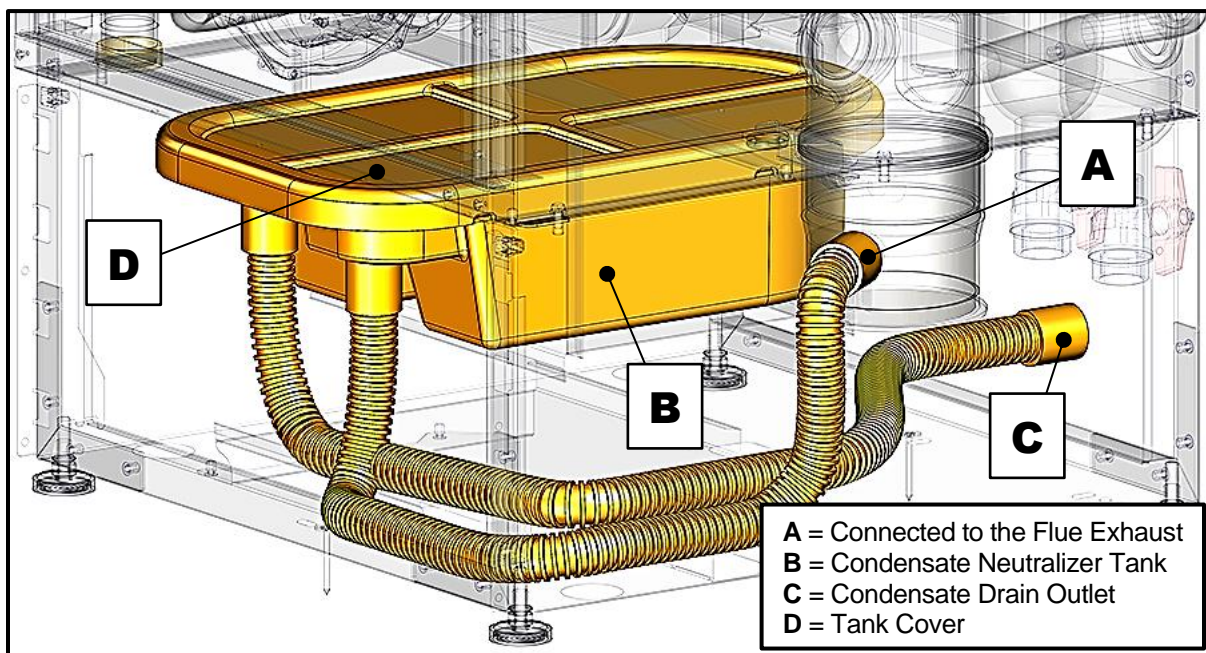

Figure 5-2: Condensate Neutralizer Tank (Unit Transparent for Clarity)

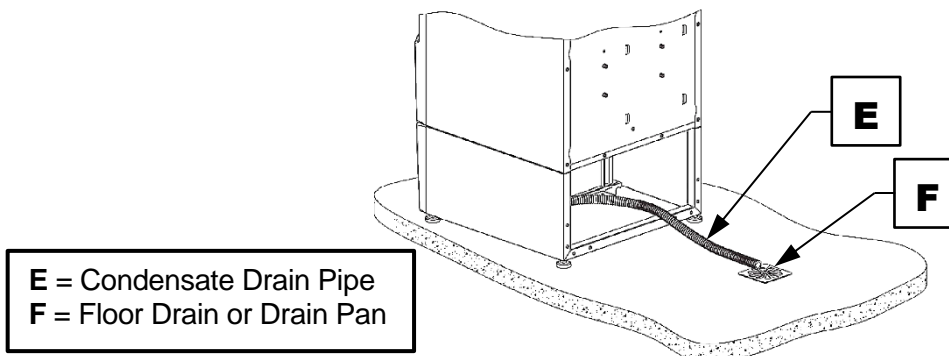

Figure 5-3: Condensate Tank Draining

A condensate removal pump is required if the boiler is below the drain. When installing a condensate pump, select one approved for use with condensing boilers and furnaces. The pump should have an overflow switch to prevent property damage from condensate spillage.

5.7 Pool Water Piping Requirements

Pool water piping must be field constructed of materials as specified. Piping must have individually isolating shutoff valves installed by the installing contractor for service and maintenance.

5.8 Pool Water Connections to the Heat Exchanger

The supply and return water piping connection size to the indirect heat exchanger is 1-1/2" NPT for models AM 399P/500P and 2" NPT for models AM 750P / 1000P.

The connections of the indirect heat exchanger to the Pool / spa water piping connections is 3" NPT for models AM 399P/500P and 3" Flg for models AM 750P / 1000P.

Attaching Pool Water Connections to Heat Exchanger

Pool water is designed to flow from left to right of when viewed from the rear of the boiler. A factory-wired return sensor is supplied with the pool heater; this is a strap-on type sensor and must be field installed onto the near the pool water inlet side of the heat exchanger.

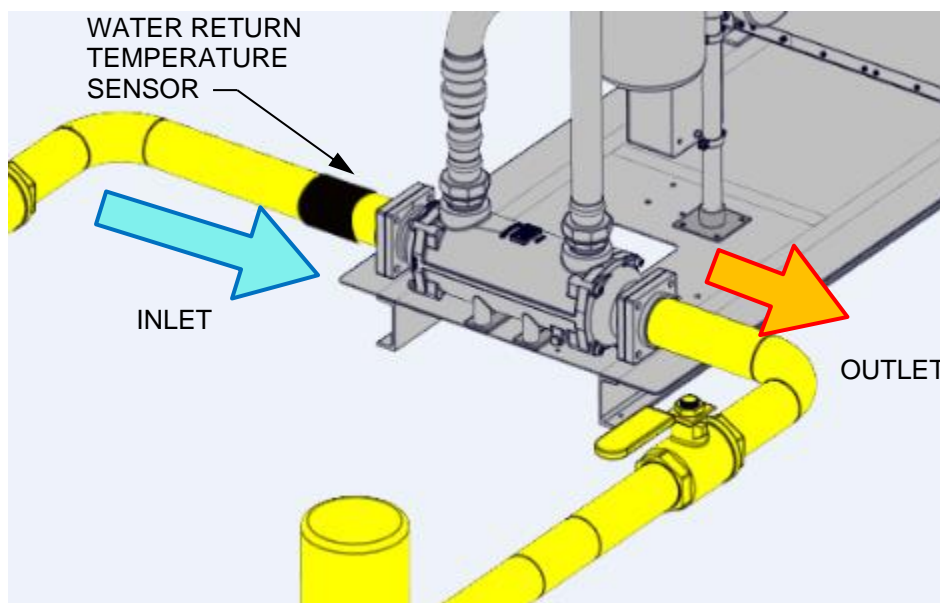

Figure 5-4: Heat Exchanger Connections and Flow Direction

5.9 Piping Methods - Full Flow or Bypass Flow

There are two recommended piping configurations for heating pool water, Full Flow and Bypass Flow. Both are described in the following subsections.

5.9.1 Full Flow Piping Method

A full flow system is recommended if the total system flow of the swimming pool or spa system is within five gallons per minute of the recommended system water flow as shown in the table below.

AM Series Pool Water Flowrates	
Model	Pool Water Flowrate
AM 399B	127 GPM
AM 500B	
AM 750B	222 GPM
AM 1000B	

An example of the configuration and necessary components for a **full flow** system are shown in Figure 5-5a.

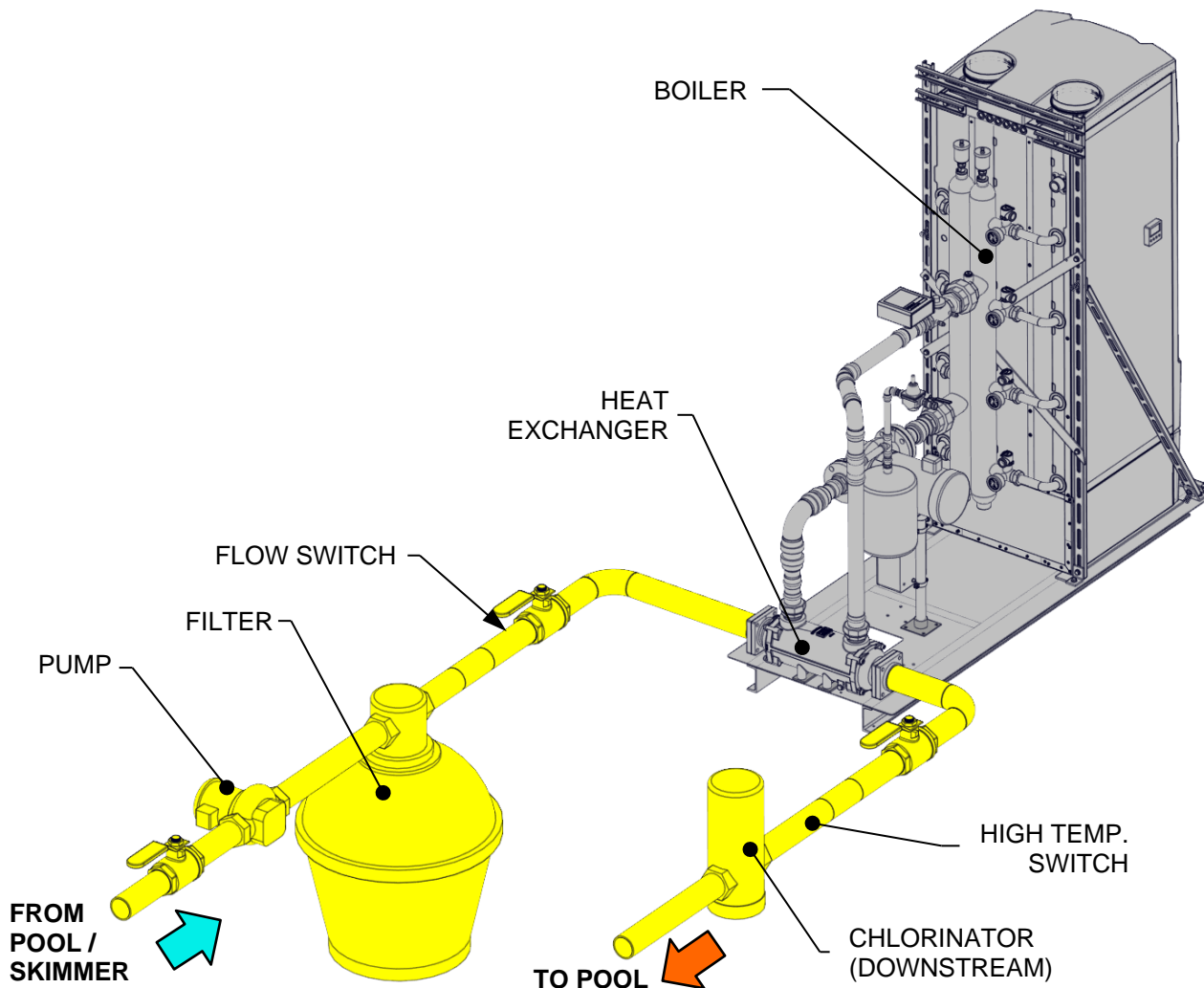

Figure 5-5a: Full Flow Piping Method

5.9.2 Bypass Flow Piping Method

A bypass flow system is recommended under one or more of the following conditions:

- If the total system flow is *greater* than the amount required by the indirect heat exchanger.
- If pool or spa water system exceeds 95°F in temperature, a bypass flow configuration is used to cool down the return flow in order to prevent tripping the high limit switch and to prevent water with temperatures over 115°F from entering the pool or spa system.
- Multiple unit installations.

An example of the configuration and necessary components for a **bypass flow** system are shown in Figure 5-5b.

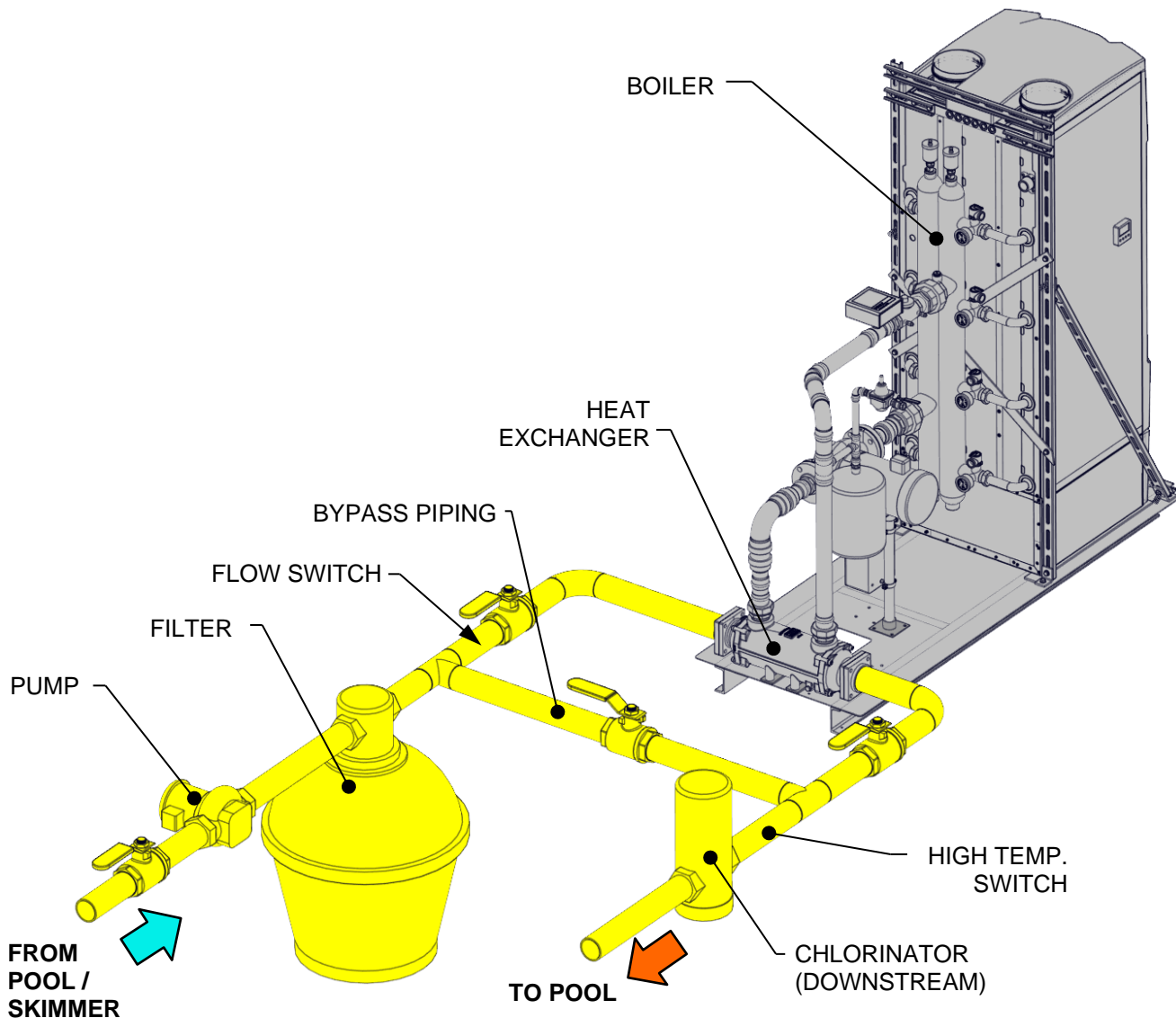

Figure 5-5b: Bypass Flow Piping Method

SECTION 6: INSTALLATION – NATURAL GAS

6.1 Gas Supply Piping

Check that the type and the pressure of the gas supplied correspond with those required for the heater as stated on the rating plate. Never use a gas different than that stated on the heater rating plate. A lockup style regulator is required on each unit any time the gas supply pressure may exceed 13" W.C. If gas supply pressure is between 3" and 13" individual regulators are recommended on every unit but not required.

NOTE:

For installation in Massachusetts an individual gas regulator is required on every unit regardless of incoming gas pressure.

6.2 Natural Gas Pressure Requirements

Each natural gas boiler requires a minimum gas pressure of 3" W.C. at gas flow rates indicated in the table below (full load rated capacity). For applications with gas supply pressure greater than 13" W.C., each boiler must be provided with an individual supply gas regulator by the installing contractor for proper gas regulation.

Gas Flow Requirements	
Model	Gas Flow (scfh)
AM 399B	399
AM 500B	500
AM 750B	750
AM 1000B	1000

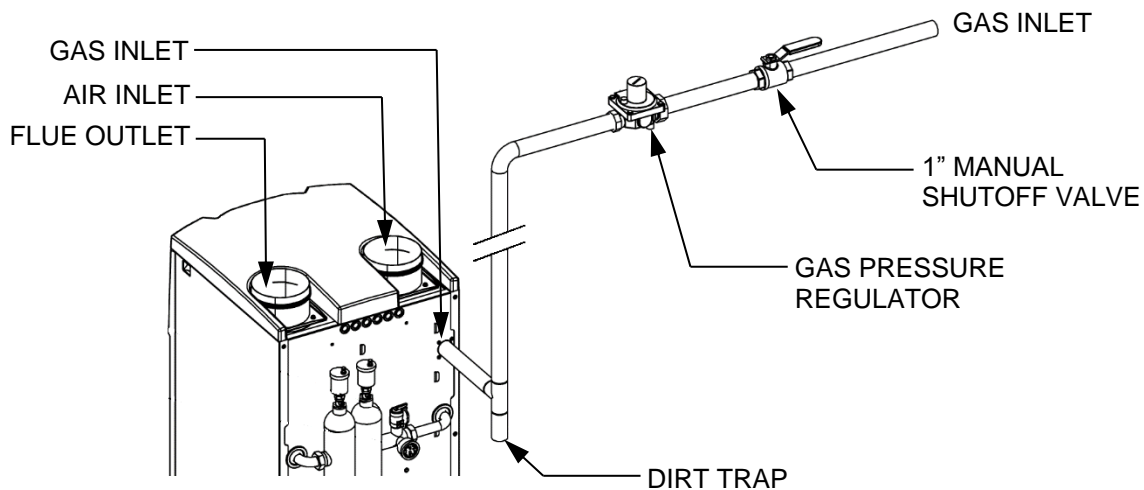

Figure 6-1: AM Series Gas Connection Example

6.3 Connection of Gas Supply Piping

Connect the gas supply to the unit as follows:

Connecting the Gas Supply to the Unit

1. Refer to Figure 6-1 for connections necessary to pipe gas to the unit.
 - a) Install ground joint union for servicing, when required.
 - b) Install a manual shutoff valve in the gas supply piping.
 - c) Manual main shutoff valves must be identified as such by the installer.
2. Install a sediment trap / drip leg. (Figure 6-1).
3. Support piping with hangers, and not from the unit or its accessories.

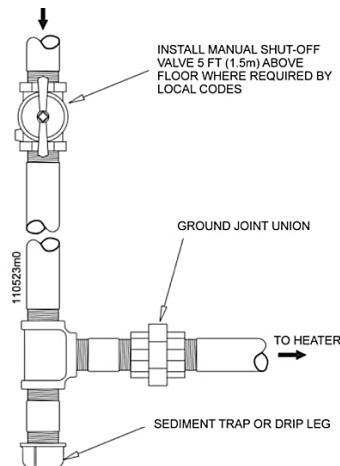

Figure 6-2: Gas Supply Piping Connections

4. Purge all air from the gas supply piping.
5. Before placing the appliance in operation, check the appliance and its gas connection for leaks.
 - a) The appliance must be disconnected from the gas supply piping system during any pressure testing of that system at a test pressure in excess of 1/2 PSIG (3.5 kPa).
 - b) The appliance must be isolated from the gas supply piping system by closing a manual shutoff valve during any pressure testing of the gas supply piping system at test pressures equal to or less than 1/2 PSIG (3.5 kPa).
 - c) The appliance and its gas connection must be leak tested before placing it in operation.
6. Use pipe sealing compound compatible with propane gas. Apply sparingly only to male threads of the pipe joints so that pipe dope does not block gas flow.

WARNING!

Do not attempt to support the weight of the piping with the water heater or its accessories. Never use an open flame to test for gas leaks. Always use an approved leak detection method. Failure to apply pipe sealing compound can result in severe personal injury, death, or substantial property damage.

The unit is shipped ready to fire on natural gas. Check appliance rating plate to determine which fuel the appliance is set for. If set to natural gas, it may be converted to propane gas following instructions in Section 7.9 of AM Series User Manual GF-146.

6.4 Natural Gas Pipe Sizing

Refer to the table below for pipe lengths and diameters. For additional gas pipe sizing information, refer to ANSI Z223.1 (or B149.1 for Canadian installations).

TABLE 7-1: Gas Pipe Capacity for Natural Gas								
Iron Pipe Size (in)								
Nominal:	3/4	1	1 1/4	1 1/2	2	2 1/2	3	4
Actual ID:	0.824	1.049	1.380	1.610	2.067	2.469	3.068	4.026
Length (ft)	Capacity in Cubic Feet of Gas per Hour							
10	273	514	1060	1580	3050	4860	8580	17500
20	188	353	726	1090	2090	3340	5900	12000
30	151	284	583	873	1680	2680	4740	9660
40	N/A	243	499	747	1440	2290	4050	8270
50	N/A	215	442	662	1280	2030	3590	7330
60	N/A	195	400	600	1160	1840	3260	6640
70	N/A	179	368	552	1060	1690	3000	6110
80	N/A	167	343	514	989	1580	2790	5680
90	N/A	157	322	482	928	1480	2610	5330
100	N/A	148	304	455	877	1400	2470	5040
125	N/A	131	269	403	777	1240	2190	4460
150	N/A	119	244	366	704	1120	1980	4050
175	N/A	N/A	224	336	648	1030	1820	3720
200	N/A	N/A	209	313	602	960	1700	3460
250	N/A	N/A	185	277	534	851	1500	3070

NOTE:

Maximum pipe capacity is based on a 0.60 specific gravity gas at a pressure of 0.5 PSIG and a 0.3" W.C. pressure drop.

6.5 Natural Gas Supply Pressure Requirements

- Install 100% lockup gas pressure regulator in supply line if inlet pressure can exceed 13"W.C. at any time. Adjust lockup regulator for 13" W.C. maximum.
- Pressure required at the gas valve inlet pressure port:
 - Maximum 13" W.C. with no flow (lockup) or with appliance off.
 - Minimum 3" W.C. with gas flowing (verify during high fire).

6.6 Propane Gas Pipe Sizing

Contact gas supplier to size pipes, tanks, and 100% lockup propane gas pressure regulator.

6.7 Propane Gas Supply Pressure Requirements

- Adjust propane supply regulator provided by the gas supplier for 13"W.C. maximum pressure.
- Pressure required at the gas valve inlet pressure port:
 - Maximum 13" W.C. with no flow (lockup) or with appliance off.

- Minimum 3" W.C. with gas flowing (verify during high fire).

NOTE:

Ensure that the high gas pressure regulator is at least 6 to 10 feet upstream of the appliance.

6.8 Checking and Adjusting the Unit Inlet Gas Supply Pressure

DO NOT adjust or attempt to measure gas valve outlet pressure. The gas valve is factory-set for the correct outlet pressure. This setting is suitable for natural gas and propane, requiring no field adjustment. Attempting to alter or measure the gas valve outlet pressure could result in damage to the valve, causing excessive levels of carbon monoxide.

The gas piping must be sized for the proper flow and length of pipe, to avoid excessive pressure drop. Both the gas meter and the gas regulator must be properly sized for the total gas load. If you experience a pressure drop greater than 1" W.C., the meter, regulator, or gas line is undersized or in need of servicing.

Refer to Section 8.6 and check the gas supply pressure.

6.9 High Altitude Operation

Calibration at high altitudes follows the normal combustion calibration procedure and is subject to a de-rating according to C302.7. See aerco.com for further information.

For installations at higher altitudes in the United States, follow local codes or, in the absence of local codes, follow ANSI Z223.1/NFPA No. 54, The National Fuel Gas Code, and check and adjust the CO₂ level following Section 8.7.

6.10 Conversion from Natural gas to Propane Gas

The gas conversion must be performed on each burner present inside the unit.

The gas conversion shall be performed by a qualified service agency in accordance with these instructions and all applicable codes and requirements of the authority having jurisdiction. The information in these instructions must be followed to minimize the risk of danger. The qualified service agency is responsible for the proper conversion of the appliance. The installation is not proper and complete until the operation of the converted appliance is checked as specified in these instructions.

Conversion shall be carried out in accordance with the requirements of the provincial authorities having jurisdiction and in accordance with the requirements of the CAN-B149.1 and CAN1-B149.2 installation code.

6.10.1 Gas Conversion Kit

The conversion kit (supplied with the unit) is composed of the following parts, which are necessary for the gas change:

- A label stating the new gas rating and settings.
- Instructions for the change.
- An orifice for each burner present in the unit.

6.10.2 Gas Conversion Instructions

Refer to the AM Series User Manual GF-146, Section 7.9.2, for gas conversion instructions.

SECTION 7: INSTALLATION - ELECTRICAL

7.1 Electrical Connections – Boiler

7.1.1 Power Supply Cable Connection

Provide and install a fused disconnect or service switch (15 amp recommended) as required by prevailing codes. To connect the electrical line voltage power supply cable, refer to Figure 7-1.

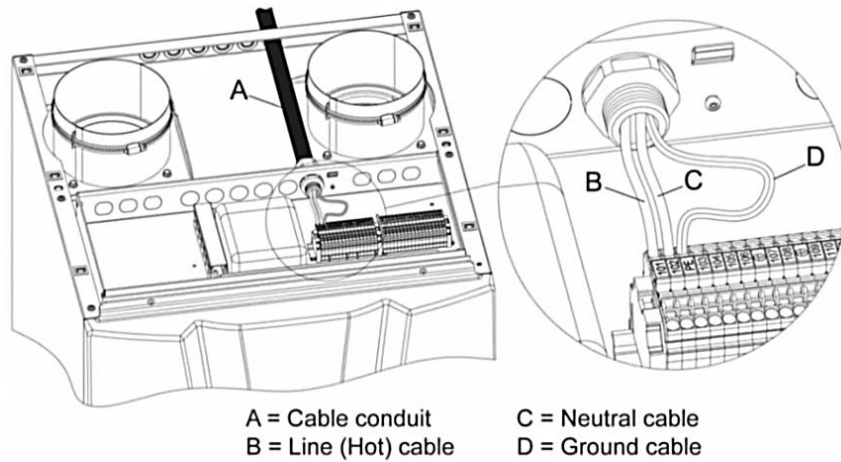

Figure 7-1: Line Voltage Connection

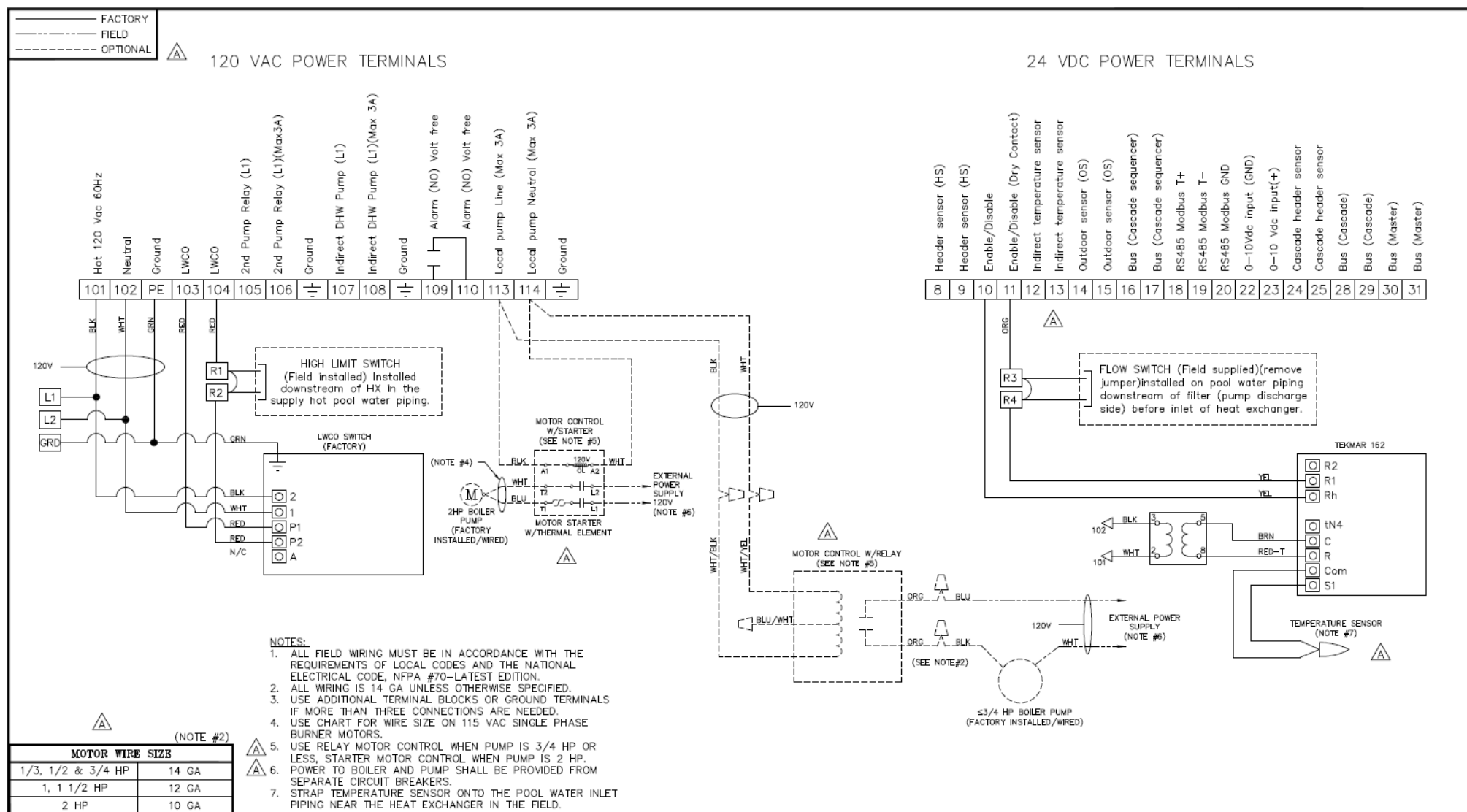

Figure 7-2: Pool Heater Boiler Electrical Connections

7.1.2 Connecting Units in Cascade

The cascade function is reserved for future implementation.

7.1.3 0-10 VDC Input Connections

The AM Series models 500, 750 and 1000 are factory supplied with a Communications Module (the 399 model can be equipped with one as an option). This allows driving the appliance via a 0-10 VDC analog input. To do this, you must connect the 0-10 VDC supply between terminals 22 and 23 (see Figure 7-3) in the electrical junction box, and the CH mode (parameter 2003 in the Installer Menu per Section 9.16 of AM Series Manual GF-146) must be set to 4 (four). When configured this way, the heater supply temperature is controlled by the analog input 0-10 VDC as shown in Figure 5-4 where:

- If the input voltage stays below 1.5V, the heater stays OFF.
- If the input voltage increases to between 1.5V and 2.0V, the heater start to operate and the supply temperature stays at the value set for the Minimum CH setpoint (parameter 3018 in the Factory menu per Appendix B in AM Series Manual GF-146).
- As the input voltage changes between 2V and 10V, the supply temperature will change proportionally between the Minimum CH setpoint (parameter 3018 in the Factory menu per Appendix B) and the Maximum CH setpoint (parameter 3017, in the Factory menu per Appendix B in AM Series Manual GF-146).

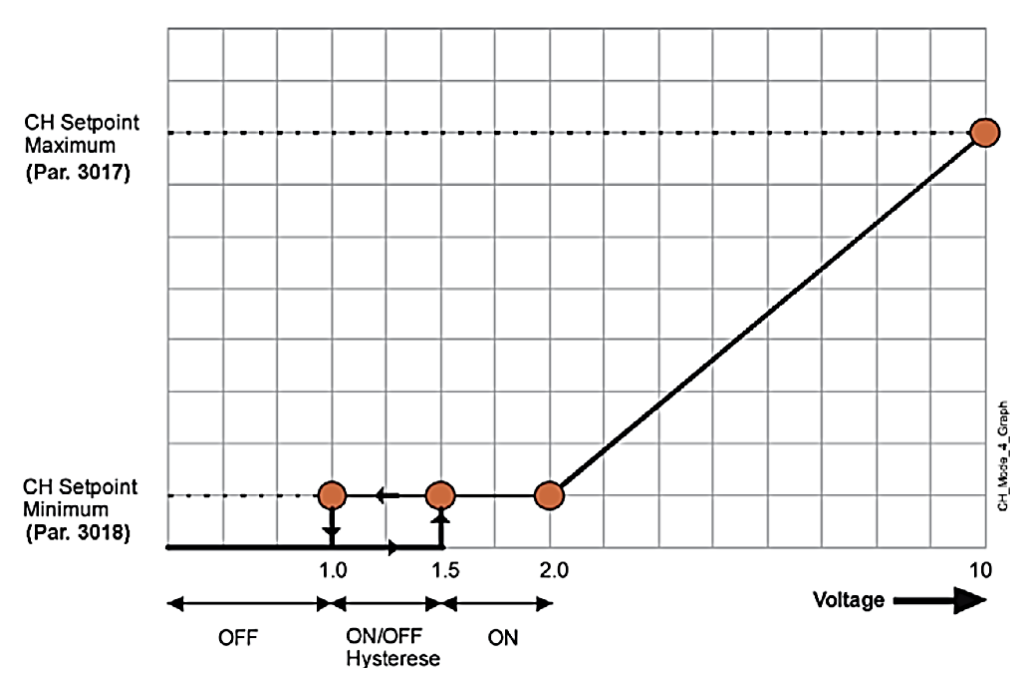

Figure 7-3: 0-10 VDC Analog Input Algorithm

7.1.4 MODBUS Interface Connections – Boilers and Water Heaters

The AM Series models 500, 750 and 1000 are factory supplied with a Communications Module (the 399 model can be equipped with one as an option). This MODBUS interface can be connected to drive the unit from a building management device. Refer to the AM Series MODBUS User Manual (GF-146-MB), which is available from AERCO technical support and the AERCO website (www.aerco.com).

7.2 Electrical Connections – Boilers Only

7.2.1 Pool Flow Switch Connections

The flow switch is field supplied and installed on the pool water piping downstream of filter (pump discharge side) and before the inlet of heat exchanger (see Figures 5-5a and 5-5b). When this switch senses a flow of cold pool water to the heat exchanger, the AM boiler is enabled. To wire this switch to the boiler, follow the instructions below:

Wiring Pool Flow Switch to the Boiler

1. Remove the boiler top cover per Section 10.14 of AM Series User manual GF-146.
2. Connect the leads of a two-conductor cable (with a minimum cross section of #18 AWG) to your enable/disable controller and run the cable to the boiler electrical junction box.

NOTE:

AERCO offers flow switch PN 64105 as an optional accessory – when using this flow switch, connect the cable leads to the COM and NO terminals of the switch; refer to the pool design flow rates and follow installation instructions that comes with the flow switch.

3. Open the boiler electrical junction box cover and connect the leads of the cable to terminals R3 and R4, as shown in Figure 7-2.
4. Enter the Installer Menu (Section 9.16 of in the AM Series User Manual, GF-146) and ensure that parameter 2003 is set to 0 (zero).

NOTE:

The maximum cable length permitted is 32 feet (10 meters). For longer lengths, up to 300 feet (100 meters), a shielded cable with the shield connected to the ground must be used.

7.2.2 Pool Water High Limit Switch Connections

The pool water high limit switch is field supplied and installed downstream of heat exchanger in the supply hot pool water piping (see Figure 5-5a and 5-5b). When this switch senses a pool water temperature above the allowed maximum, the AM boiler is shut down. To wire this switch to the boiler, follow the instructions below:

1. Remove the boiler top cover per Section 10.14 of AM Series User Manual GF-146.
2. Connect the leads of a two-conductor cable (with a minimum cross section of #18 AWG) to the pool water high limit switch and run the cable to the boiler electrical junction box. AERO offers an auto-reset pool water high limit switch PN 64115 as an optional accessory; refer to the pool design temperatures and follow installation instructions that comes with the high limit switch.
3. Open the boiler electrical junction box cover and connect the leads of the cable to terminals R1 and R2 (see Figure 7.2).

SECTION 8: UNIT STARTUP

WARNING!

The technician in charge of unit start-up **must** refer to **Section 8** of the AM Series User Manual, **GF-146**, for start-up information and instructions, including combustion calibration and other necessary adjustments, procedures, and warnings. Attempting any of these procedures without reference to GF-146 risks creating a dangerous situation and/or damaging equipment or property.

SECTION 9: OPERATION

REFERENCE NOTE:

For all information regarding the detailed operation of the unit via the front panel controls and display of the boiler, the technician who operates the pool heater must refer to **Section 9** of the AM Series User Manual, **GF-146**.

SECTION 10: BOILER MAINTENANCE

REFERENCE NOTE:

For all information regarding the detailed 12-month and 24-month maintenance of the boiler, the technician who maintains the pool heater must refer to **Section 10** of the AM Series User Manual, **GF-146**.

SECTION 11: BOILER TECHNICAL DATA

REFERENCE NOTE:

For all information regarding the technical data of the boiler, refer to **Section 12** of the AM Series User Manual, **GF-146**.

SECTION 12: BOILER PARTS DRAWINGS & LISTS

REFERENCE NOTE:

For all information regarding the detailed spare parts and lists for the boiler, refer to **Section 13** of the AM Series User Manual, **GF-146**.

SECTION 13: SYSTEM PART DRAWINGS AND LISTS

13.1 AM 399P/500P Pool Heating System Parts Drawing and List

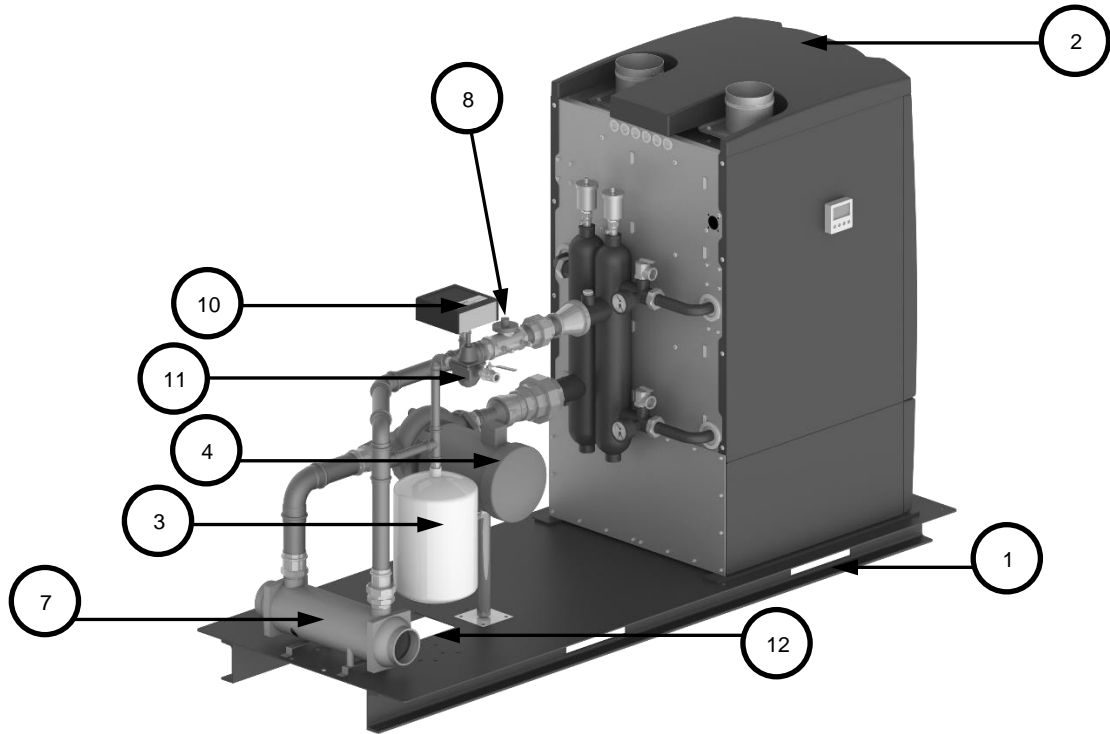

Equipment List		
Models: AM399P-016		
AM500P-016		
Item	Part	Description
1	-	Base
2	AM399B/AM500B	Boiler
3	0066605	Expansion Tank
4	99124	Pump
5	63063	Relay*
6	N/A	Starter
7	16050265-001	Pool Heat Exchanger
8	92081-2.5	Circuit Setter
9	N/A	Thermal Unit
10	121700	Low Water Cutoff
11	0386425	Press Reducing Valve
12	61053	Water Return Temperature Sensor

*Not visible externally

Equipment List Models: AM399P-075 AM500P-075		
Item	Part	Description
1	-	Base
2	AM399B/AM500B	Boiler
3	0066605	Expansion Tank
4	99126	Pump
5	63190	Relay*
6	N/A	Starter
7	16050265-001	Pool Heat Exchanger
8	92081-2.5	Circuit Setter
9	N/A	Thermal Unit
10	121700	Low Water Cutoff
11	0386425	Press Reducing Valve
12	61053	Water Return Temperature Sensor

*Not visible externally

13.2 AM 750P/1000P Pool Heating System Parts Drawing and List

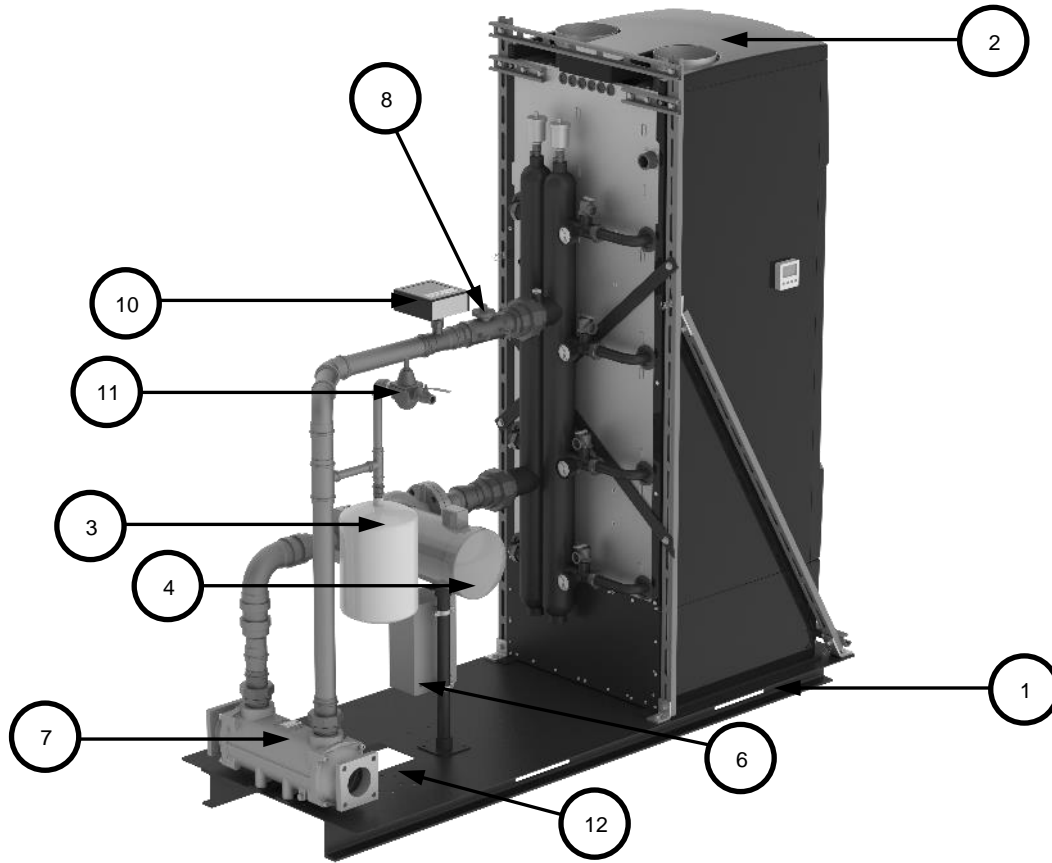

Equipment List Models: AM750P-016 AM1000P-016		
Item	Part	Description
1	-	Base
2	AM750B/AM1000B	Boiler
3	0066605	Expansion Tank
4	99124	Pump
5	63063	Relay*
6	N/A	Starter
7	28567	Pool Heat Exchanger
8	92081-2.5	Circuit Setter
9	N/A	Thermal Unit
10	121700	Low Water Cutoff
11	0386425	Press Reducing Valve
12	61053	Water Return Temperature Sensor

*Not visible externally

Equipment List Models: AM750P-075 AM1000P-075		
Item	Part	Description
1	-	Base
2	AM750B/AM1000B	Boiler
3	0066605	Expansion Tank
4	99126	Pump
5	63190	Relay*
6	N/A	Starter
7	28567	Pool Heat Exchanger
8	92081-2.5	Circuit Setter
9	N/A	Thermal Unit
10	121700	Low Water Cutoff
11	0386425	Press Reducing Valve
12	61053	Water Return Temperature Sensor

*Not visible externally

Equipment List Models: AM750P-200 AM1000P-200		
Item	Part	Description
1	-	Base
2	AM750B/AM1000B	Boiler
3	0066605	Expansion Tank
4	69231	Pump
5	N/A	Relay
6	63191	Starter
7	28567	Pool Heat Exchanger
8	92081-2.5	Circuit Setter
9	69272-30	Thermal Unit*
10	121700	Low Water Cutoff
11	0386425	Press Reducing Valve
12	61053	Water Return Temperature Sensor

*Not visible externally

Equipment List Models: AM1000P-040		
Item	Part	Description
1	-	Base
2	AM1000B	Boiler
3	0066605	Expansion Tank
4	99125	Pump
5	63190	Relay*
6	N/A	Starter
7	28567	Pool Heat Exchanger
8	92081-2.5	Circuit Setter
9	N/A	Thermal Unit
10	121700	Low Water Cutoff
11	0386425	Press Reducing Valve
12	61053	Water Return Temperature Sensor

*Not visible externally

AM SERIES POOL HEATER WARRANTY:

The pressure vessel/heat exchanger of the **boiler** carries a non-prorated 7 year warranty against failure due to condensate corrosion, thermal stress, mechanical defects or workmanship. All other boiler components carry an 18-month warranty against failure due to defective materials or workmanship.

If any part of **skid package** fails because of a manufacturing defect within one year from system startup date or 18 months from the ship date, factory shall furnish from manufacturer's organizations, without charge, the required replacement part.

NOTE:

Refer to the AERCO website (www.aerco.com) for specific warranty information concerning the AM Series boiler and heat exchanger used in the AM Series pool heater.

Change Log:

DATE	DESCRIPTION	CHANGED BY
11/29/2018	Rev A: Initial release.	
10/29/2019	Rev B: Parts List Update (Section 13.2); Wiring Update (Section 7)	Linley Thobourne