

26.7 [67.7]
TUBE PULL
CLEARANCE

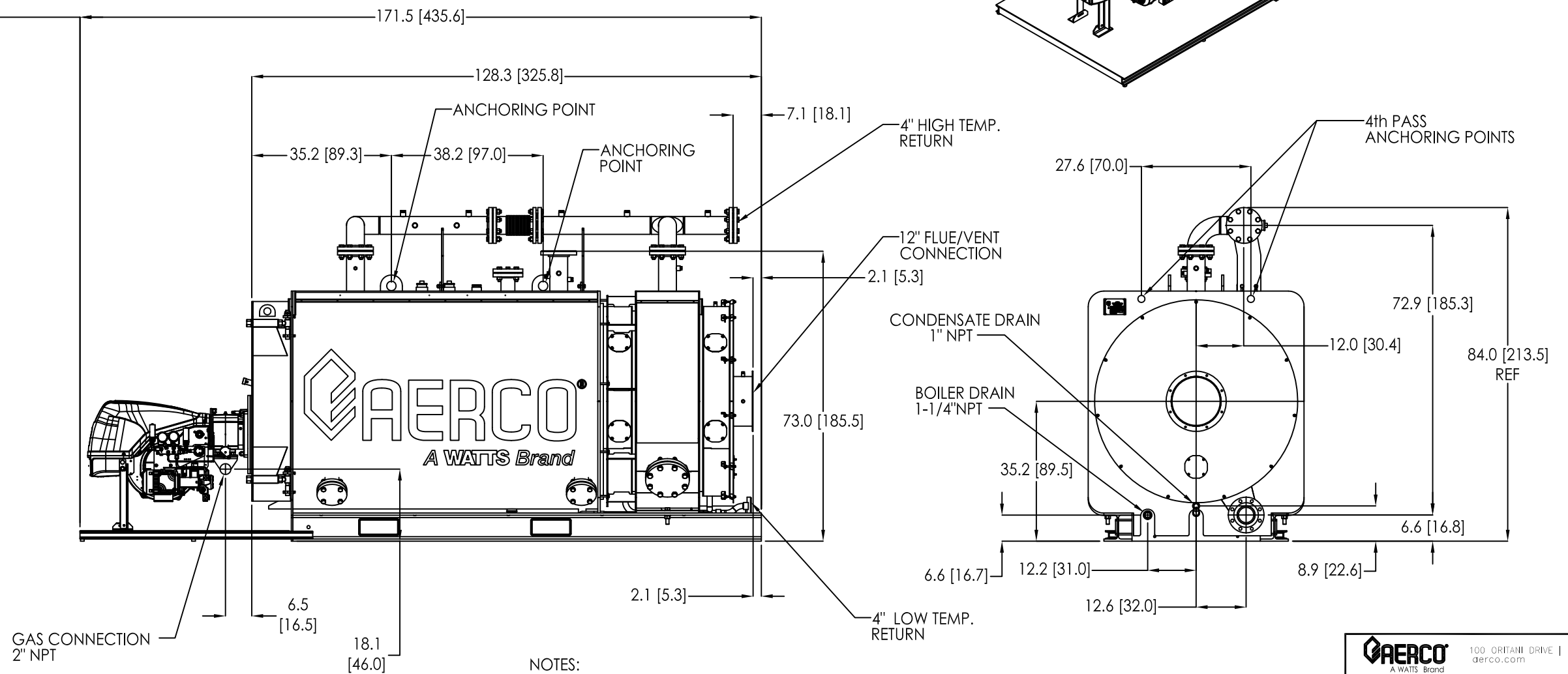
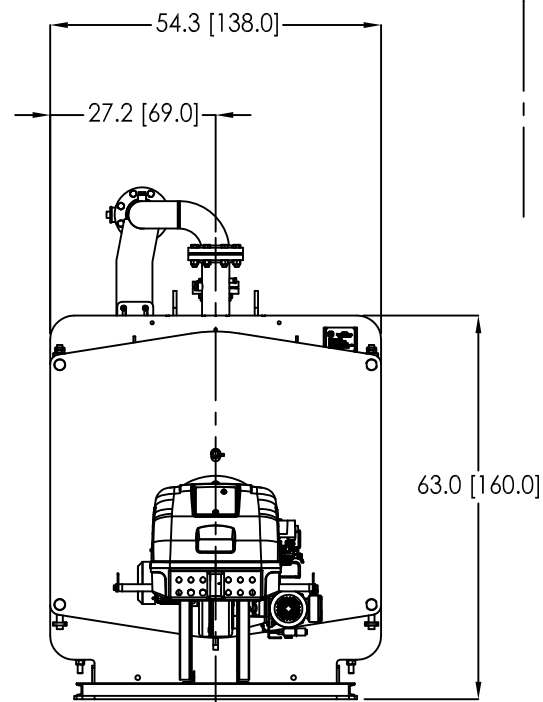

NOTES:

- 1) ALL DIMENSIONS SHOWN ARE IN INCHES [CENTIMETERS].
- 2) RELIEF VALVE, TRIDICATOR & CONDENSATE TRAP ARE INCLUDED SEPARATELY IN SHIPMENT.
- 3) AERCO RESERVES THE RIGHT TO MODIFY BOILER DIMENSIONS WITHOUT PRIOR NOTICE.
- 4) FOR ADDITIONAL INFORMATION, PLEASE CONTACT AERCO APPLICATIONS ENGINEERING.
- 5) SEE VENTING GUIDE GF-148-V FOR MINIMUM EXHAUST VENT DIAMETER.

AERCO
A WATTS Brand

100 ORITANI DRIVE | BLAUVELT, NY 10913
aerco.com

MFC 3000 ASSEMBLY
DIMENSIONAL DRAWING

DWN.BY K.S. DATE 061616
SCALE NTS
REV.DATE K.S. - 091421

AP-A-1040

REV.
C