

MATERIALS OF CONSTRUCTION
HEAT EXCHANGER: 316 (Ti)
HEAT EXCHANGER DESIGN STANDARDS
MAX. WORKING PRESS. (PSIG): 160
MAXIMUM TEMP. (°F): 210
TEST PRESS. (PSIG): 240
WATER HEATER UNITS: ASME-HLW STAMP

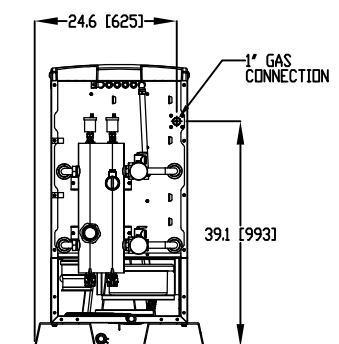
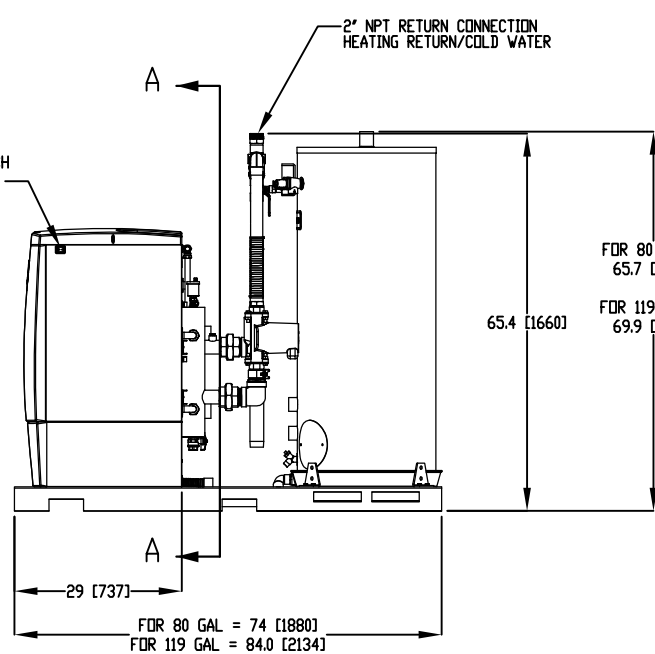
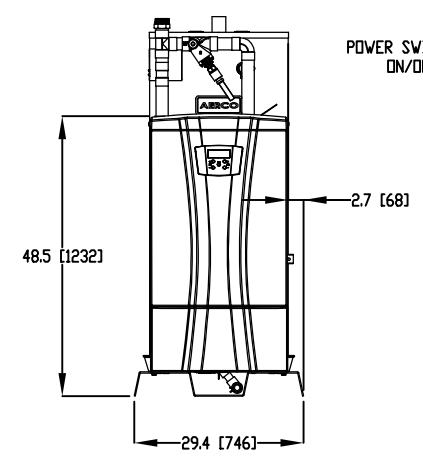
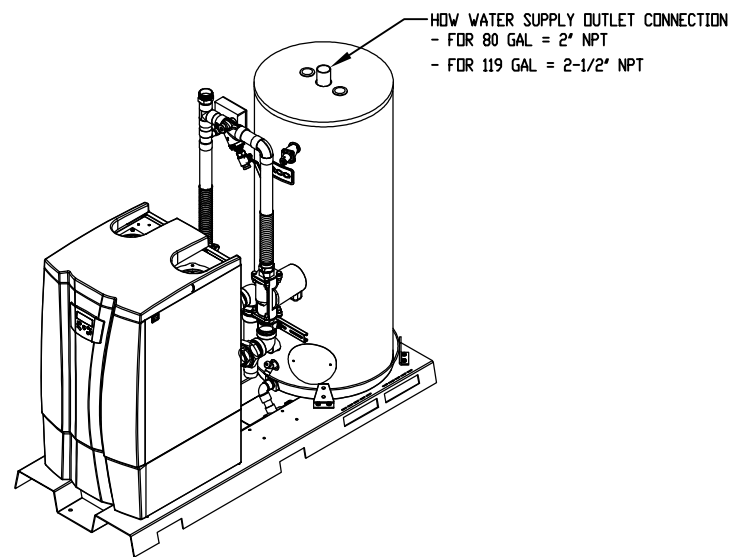
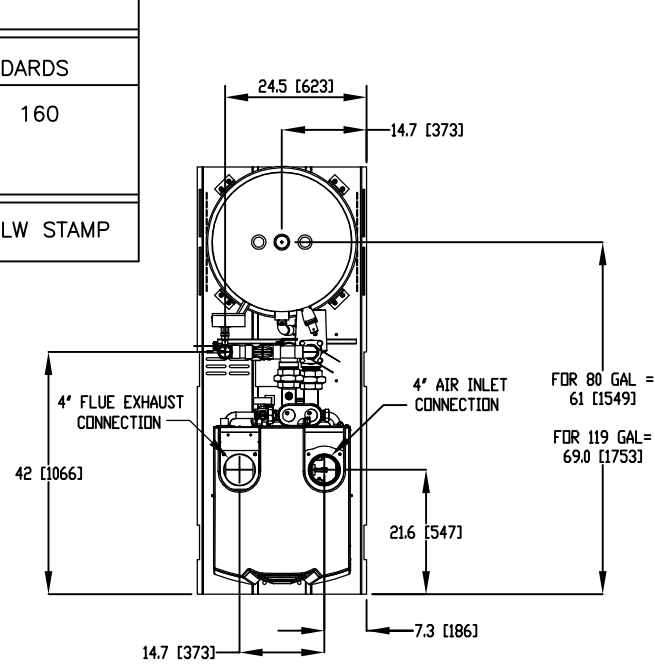

NOTES:
 1) ALL DIMENSIONS SHOWN ARE IN INCHES (MILLIMETERS).
 2) RELIEF VALVE AND TRIDICATOR ARE INCLUDED ONE SET ON EACH MODULE.

AERCO INTERNATIONAL, INC.
 Blauvelt, NY 10913

AMRS 399, 500 WATER HEATER
 DIMENSIONAL DRAWING

DWN.BY J.R. DATE 050415	REV.
SCALE _____ SIZE <u>A</u>	AP-A-1013 C
CHKD. _____ APPD. _____	
REV.DATE _____	