

Technical Data Sheet

AM Rapid Recovery Water Heaters

The Advanced Modular Rapid Recovery water heaters from AERCO provide a complete water heating solution in one convenient package. With a packaged integrated thermal buffer, pump, and required piping, the AMR series is the easiest solution for domestic water heating from 199 to 500 MBTUs. All of the great features of the AM Series remain, from the built-in redundancy to the small footprint. The AMR is ready for fast installation to get your domestic water heating plant up and running quickly. Multiple units can be located with near-zero side clearance for even larger installations.

The AMR ships ready to be piped into a domestic water heating system to provide hot water immediately. The AMR is great for new construction to save space as well as for replacement of existing equipment; all sizes fit through a standard doorway. As with all AERCO boilers and water heaters, high efficiency and low emissions are hallmark features to provide the best performance for your system.

Features

- High efficiency condensing water heater
- Natural gas or propane
- Superior turndown means low operating cost and tight temperature control
- Complete heating plant in one package
- Direct or conventional vent with PVC, cPVC, Polypropylene, or AL29-4C
- Concentric vent capability
- Common vent capability
- Unparalleled reliability
- Minimal maintenance
- Small footprint saves space and makes retrofits a breeze
- Easy front access for serviceability
- Low NOx <20ppm
- Supports integration to BAS System
- Modbus communication



AM 199 through AM 500 R



Same Great AM Features

Each unit contains between 1 and 2 modules to provide both high turndown and the reliability that is key to the AM Series design. The multiple burners in the 399-500 means the peace of mind with increased reliability and built-in redundancy, yet have the benefit of a single water heater with a space saving design. The built in condensate neutralizer allows the AMR to be installed without a housekeeping pad, making the AMR ideal for retrofits in any location. The heat exchanger is designed specifically with water heating in mind; multiple parallel passes and large diameter rounded tubes means the AMR is much less susceptible to scale buildup than other water tube designs. Superior turndown means both high efficiency and tight temperature control. An industry-best warranty provides further peace of mind.

Ratings

Model	Min Input (BTU)	Max Input	Max Output*	GPH @ 100°F Rise	AHRI Thermal Efficiency
AM 199RI	50,000	199,000	190,000	226	90%
AM 250RI	50,000	250,000	237,500	285	91%
AM 399RI	50,000	399,000	379,000	455	92%
AM 500RI	50,000	500,000	475,000	570	94%

*BTU output depends on several factors, including supply and return water temperatures. Please contact your local factory representative for further details.

Unique Design

The unique construction makes the AMR a versatile option for your domestic water heating needs. Eliminating large storage volumes means the heat you pay for goes directly into the water.



AM Rapid Recovery Integrated (AMRI)

Specifications

	AM 199RI	AM 250RI	AM 399RI	AM 500RI
Boiler Category	II & IV	II & IV	II & IV	II & IV
Gas Connections (NPT)	1"	1"	1"	1"
Min. Gas Pressure	3"	3"	3"	3"
Max. Gas Pressure	13"	13"	13"	13"
Max. Working Pressure (PSI)	160	160	160	160
Water Connections (NPT)	1 1/4"	1 1/4"	1 1/4"	1 1/4"
Electrical Req: 120V (Amp)	15	15	15	15
ASME Buffer Volume (gal)	32	32	32	32
Thermal Modules	1	1	2	2
Turndown	4:1	5:1	8:1	10:1
Vent Size	3"	3"	4"	4"
Vent Materials	PVC*, cPVC, Polypropylene, Stainless Steel			
Gas Type	Natural Gas or Propane			
Temperature Control Range	Water Heater delivers 68-180°F			
Noise Level	<70 dBA			
Max. Condensate Production (gal/hr)	1.9	2.3	3.8	4.6
Standards, Listings, and Approvals	ASME, CSA, NSF 372 low lead, SCAQMD			

*For applications with return water temperature >145°F, the design ΔT must be >35°F to allow the use of PVC venting. For further information contact your local sales representative.

Recovery Capacities (GPM)

Model	40°F ΔT	60°F ΔT	80°F ΔT	100°F ΔT	120°F ΔT	140°F ΔT
AM 199RI	9.5	6.3	4.7	3.8	3.2	2.7
AM 250RI	11.9	7.9	5.9	4.8	4.0	3.4
AM 399RI	19.0	12.6	9.5	7.6	6.3	5.4
AM 500RI	23.8	15.8	11.9	9.5	7.9	6.8

Dimensions

Model	Height	Width	Depth	Weight (wet)	Weight (shipping)
AM 199RI	71.4"	23.6"	34.2"	550	300
AM 250RI	71.4"	23.6"	34.2"	630	375
AM 399RI	71.4"	23.6"	34.2"	815	540
AM 500RI	71.4"	23.6"	34.2"	930	650

*AMRS depth for 119 gallon tank is 84"

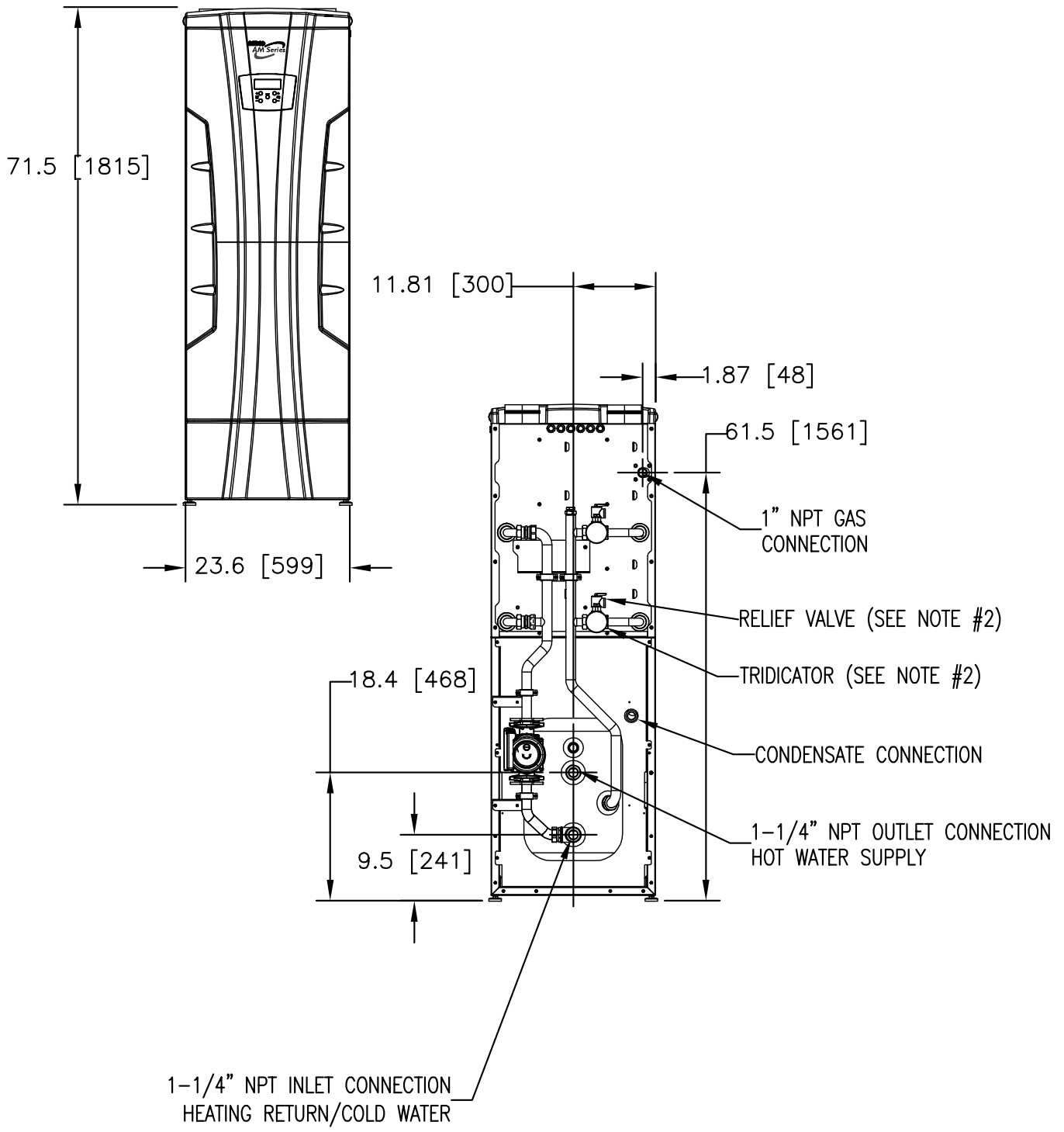

Heating and Hot Water Solutions

AERCO International, Inc. • 100 Oritani Drive • Blauvelt, NY 10913
USA: T: (845) 580-8000 • Toll Free: (800) 526-0288 • AERCO.com