



Operation & Maintenance Manual

AquaSolve®

Anti-Scale Systems
Chemical-Free, Salt-Free
Scale Prevention

AM8414TM-COM (50 GPM)
AM8416TM-COM (75 GPM)



Important: Read this Manual BEFORE using this equipment. Failure to read and follow all safety and use information can result in death, serious personal injury, property damage, or damage to the equipment. Keep this Manual for future reference.

Heating and Hot Water Solutions

OMM-0154-AquaSolve-AM8414TM-AM8416TM

AERCO International, Inc. • 100 Oritani Drive • Blauvelt, NY 10913
USA: T: (845) 580-8000 • Toll Free: (800) 526-0288 • AERCO.com
Technical Support • (800) 526-0288 • Mon-Fri, 8 am - 5 pm EST

© 2-2025 AERCO

INTRODUCTION

The AquaSolve Anti-Scale System provides protection from scale formation on internal plumbing surfaces. The AquaSolve system can be installed at the point of entry to a building to treat both hot* and cold water, or it can be located directly before a water heater, boiler, or other water using device that requires protection from hard water.

AquaSolve prevents scale by transforming the normal dissolved hardness minerals into undissolved crystal microparticles. These crystals stay suspended in the water and have a greatly reduced ability to react and attach to surfaces like dissolved hardness does. Therefore the problem of internal buildup of scale in pipes, water heaters and on fixtures and glass is greatly reduced.

AquaSolve is not a water softener or a chemical additive (like antiscalants or sequestrants). It is a scale prevention device with proven third party laboratory test data and years of successful residential and commercial installations. AquaSolve is the one water treatment device that effectively provides scale protection and is a great saltfree alternative to water softening (ion exchange) or scale sequestering chemicals. Laundry and warewashing chemistry will likewise require adjustments.

AquaSolve Benefits

- Chemical-free scale prevention and protection – converts hardness minerals to harmless, inactive microscopic crystals making AquaSolve an effective alternative technology to a water softener for the prevention of scale due to water hardness
- Virtually maintenance free – no control valve
- Uses environmentally friendly technology by using no salt or other chemicals to constantly add, no electricity and no wastewater
- Improves efficiency of all water using appliances – both hot* and cold
- Simple sizing and installation – all you need to know is pipe size and the peak flow rate
- Safe for landscaping and lawn watering, no need for costly bypass plumbing

- Compatible with all on-site and community wastewater treatment systems
- Perfect system for towns or communities where water softeners are banned or restricted
- For high-flow applications**, install multiple tanks in parallel
- AquaSolve does not remove minerals or add sodium to the water supply
- AquaSolve can be installed as pre-treatment to commercial reverse osmosis systems (contact your AERCO representative for further details)

*For hot water applications where feed water temperature is 100° - 140°F (38° - 60°C), please contact AERCO Technical Support.

**For high-flow applications, contact your AERCO Representative for details on larger, multi-tank systems plumbed in parallel that can meet high flow applications from 100 gpm to and above 1000 gpm.

The wetted surface of this product contacted by consumable water contains less than 0.25% of lead by weight.

WARNING

Do not use with water that is microbiologically unsafe or of unknown quality without adequate disinfection before or after the system.



Systems are certified through WQA against NSF/ANSI/CAN Standard 61, CSAB483.1, and to NSF/ANSI 372 for Lead Free compliance.

Specifications

AquaSolve scale prevention system shall be installed on the main water service pipe just after it enters the building, but after other whole building water safety devices (backflow preventers or pressure reducing valves), to effectively address water hardness concerns. A system may also be installed further downstream to protect specific equipment or areas within a plumbing system. The system shall be plumbed with a bypass valve to allow isolation of tank(s) and to allow the bypass of untreated water in the event that service or media replacement be necessary. The installation area should be suitable in size for the tank(s) to be serviced without encumbrance and sit upright on a flat level surface.

The system must operate in an upflow manner and does not require additional water to backwash, flush, or regenerate once put into service. The system does not require any chemical additives and does not require electricity for operation.

Multi-tank systems shall be installed in parallel with PVC/CPVC manifold to meet peak flow rate requirements – see image below.



Standards

Independent scientific testing has confirmed media assisted crystallization technology provides scale reduction of over 95+%. Testing was conducted under protocol based on DVGW W512 test to access control of scale formation.

NOTICE

Spotting May Occur on External Plumbing Surfaces.

AquaSolve media systems perform best in single pass potable water applications with NO additional chemical additives. Depending on hardness, soft scale spotting may occur. Soft scale spots in most cases can be easily wiped down with a damp cloth and will not form hard scale deposits. A Point of Use (POU) Water Softener should be used on mandatory spot-free applications (e.g. glass stemware, dishware).

CAUTION

- Not for use on closed loop systems.
- Do not let the system freeze. Damage to the tank may result.
- System must be operated in a vertical position. Do not lay it down during operation. The system may be placed in any position for shipping and installation but must be operated in the vertical position.
- Place the system on a smooth, level surface. Because the system operates in an upflow, fluidized bed mode, having a level surface is more important than with a softener or media filter.
- A bypass valve should be installed on every system to facilitate installation and service.
- Observe all local plumbing and building codes when installing the system.

WARNING

Using AquaSolve With Other Water Treatment Equipment.

Due to the unique properties of AquaSolve, there are some unique requirements for using AquaSolve in conjunction with other forms of water treatment:

1. AquaSolve must be the last stage in the treatment chain. Do not install any filters after AquaSolve or before any devices for which scale prevention is required. POU filters, e.g. carbon, RO or Ultraviolet (UV) are exempt from this requirement.
2. Do not apply any other antiscalants before or after AquaSolve.
3. The addition of soaps, chemicals, or cleaners, before or after AquaSolve treatment, may reverse its anti-scale treatment effects and/or create water with a heavy residue or spotting potential. Any adverse conditions caused by the addition of soaps, chemicals, or cleaners are the sole responsibility of the end user.
4. AquaSolve is not a water softener and does not soften the water - water treatment chemistry (e.g. antiscalants, sequestrants, soaps, chemicals or cleaners etc.) will most likely have to be changed to be compatible with AquaSolve treated water. Laundry and ware-washing chemistry will likewise require adjustments.

Equipment Specifications

AquaSolve systems are complete, self-contained, loaded with media, and ready to use. A simple inlet and outlet connection is all that is required for installation. Please review operating pressures, temperatures and water chemistry limitations to ensure compatibility.

Feed Water Chemistry Requirements

pH	6.5-8.5
Hardness (maximum)	30 grains (513 ppm CaCO ₃)*
Water Pressure	23 psi to 150 psi (1.58 to 10.34 bar)
Temperature	40°F to 100°F (5°C to 38°C)
Free Chlorine	< 2 ppm
Iron (maximum)	0.3 ppm**
Manganese (maximum)	0.05 ppm**
Copper (maximum)	1.3 ppm***
Oil & H ₂ S	Must be Removed Prior to AquaSolve
Total Phosphates	< 3.0 ppm
Silica (maximum)	20 ppm****
TDS	< 1500 mg/l*****

NOTICE

Water known to have heavy loads of dirt and debris may require pre-filtration prior to AquaSolve.

*Systems using AquaSolve technology are effective at controlling lime-scale formation inside the plumbing system at influent hardness levels up to 75 grains per gallon (1282 mg/l) of calcium carbonate. Due to variances in water chemistry, 30 grains per gallon is a recommended hardness maximum due to potential aesthetic issues related to soft scale residue formation outside of the plumbing system. Testing should be performed to determine proper application where hardness levels exceed 30 grains per gallon.

**Just as with conventional water softening media, AquaSolve media needs to be protected from excess levels of certain metals that can easily coat the active surface, reducing its effectiveness over time. Public water supplies rarely, if ever, present a problem, but if the water supply is from a private well, confirm that the levels of iron (Fe) and manganese (Mn) are less than 0.3 mg/L and 0.05 mg/L, respectively.

***Pursuant to the EPA drinking water standards, the copper concentration permitted is up to 1.3 ppm. Typically originating from new copper plumbing, high levels of copper can foul AquaSolve media. For applications with copper concentration greater than 1.3 ppm, please consult AERCO Systems Engineering. To further minimize any problem with excess copper, avoid applying excessive flux on the inner surfaces of the pipe and use a low-corrosivity water soluble flux listed under the ASTM B813 standard.

****AquaSolve media does not reduce silica scaling. While silica tends to have a less significant effect on scale formation than other minerals, it can act as a

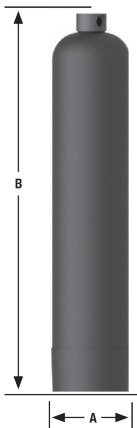

binder that makes water spots and scale residue outside the plumbing system difficult to remove. This 20 ppm limitation is for aesthetic purposes.

*****All other contaminants must meet the requirements of the USEPA Safe Drinking Water Act. Specific Mineral and Metal MCL's, identified in AERCO published Feed Water Chemistry Requirements, supersedes the USEPA SDWA.

NOTICE

Systems using AquaSolve technology prevent hard water scale formation inside the plumbing system at influent hardness levels of 30 grains per gallon of calcium carbonate and less. Due to variances in water chemistry, certain aesthetic conditions external of the plumbing system may not be attained. AquaSolve is designed for the treatment of potable water that meets the requirements of the current USEPA Safe Drinking Water Act.

Mechanical Specifications							
Model	AM8414TM-COM	AM8416TM-COM					
Dry Weight lbs/kg	124 / 56	145 / 66					
Service Weight lbs/kg	458 / 208	550 / 250					
Inlet/Outlet Connection	2" FNPT	2" FNPT					
Replacement Media							
Model	Part #	Frequency					
AM8414TM-COM	144907	Media should be replaced every 3 years					
AM8416TM-COM	144908	Media should be replaced every 3 years					
Dimensions (nominal - inches)							
Model	AM8414TM-COM	AM8416TM-COM					
A	14	16					
B	73.1	73.1					
Max. Service Flow (gpm) vs. Water Temp. (°F)							
System	40°	45°	50°	55°	60°	65°	70°
AM8414TM-COM	40	44	48	50	50	50	50
AM8416TM-COM	45	51	56	59	63	69	75
Intermittent Duty Systems							
AM8414TM-COM	50 gpm at all temperatures						
AM8416TM-COM	75 gpm at all temperatures						
Max. Flow Rate*****							
AM8414TM-COM	50 gpm			189 lpm			
AM8416TM-COM	75 gpm			284 lpm			

*****Exceeding maximum flow can reduce effectiveness and void warranty.

Pressure drop at peak flow rate is less than 22 psi. Pressure drop reading taken with inlet and outlet gauges installed at a common elevation and 80°F feed water.

Intermittent duty is defined as less than 2 hours of Maximum Flow per 24 hour period. Higher Flow rates can be achieved by combining systems in an array.

Installation

Tighten the tank head

NOTICE

Check the head on top of the tank. It's common for it to loosen during shipment. Tighten the head with a strap wrench as needed.

NOTICE

*It is very important to use flexible connections on the inlet and outlet plumbing in the horizontal orientation as shown in the images on this page. The tanks expand and contract with water pressure fluctuations. Flexible connectors will prevent plumbing and tank leaks. The part number for the suggested AERCO 2" Flexible Connectors is 144065 (Two are included and required for installation).

Anytime AquaSolve systems are installed above the ground floor of a building it is recommended that a vacuum relief valve also be installed to protect against tank collapse in the event the plumbing system is drained. If a vacuum relief valve is not used then the system should be placed in bypass anytime the plumbing system is drained. The part number for suggested vacuum relief valve is 92165 (not included). The vacuum relief valve should be installed on the outlet of the system.

NOTICE

- We recommend the installation of a dual-union ball-valve on the inlet and outlet to isolate the tank for servicing.
- A full bypass should be installed so that the full service flow can be routed around the system as needed for servicing.

Install Piping

Connect the inlet and outlet plumbing according to your preferences and any applicable local codes. Include sample/drain ports with hose-bibb connections on the inlet and outlet piping to facilitate startup and service.

WARNING

Support the Piping

2 inch Flex Connectors must be installed horizontally not vertically in the water pipe line. The full weight of the piping and valves must be supported by uni-strut, pipe hangers or other means. The tank connections cannot support the weight of the piping. The image below for a multi-tank system installation shows properly supported piping.

Start-Up

Connect a hose to the hose bibb on the outlet of the tank. Run the hose to a drain and open the hose bibb.

Slowly/partially open the supply water ball valve. Allow the tank to slowly fill with water. When a

steady stream of water appears at the drain, close the supply valve and hose bibb. Once the tank is full, wait 4 hours for media to "hydrate".

Slowly open the inlet and outlet valves on the system. Transfer the bypass valve from Bypass to the Service position. Open a nearby faucet downstream from the AquaSolve system to relieve any air.

Check for leaks. Repair as needed.

NOTICE

Fill in install date and rebed due date on product label located on front of each tank as reminder to replace AquaSolve media every 3 years. The system is now ready for operation.

Typical Installation for Single and Multi-Bank Systems

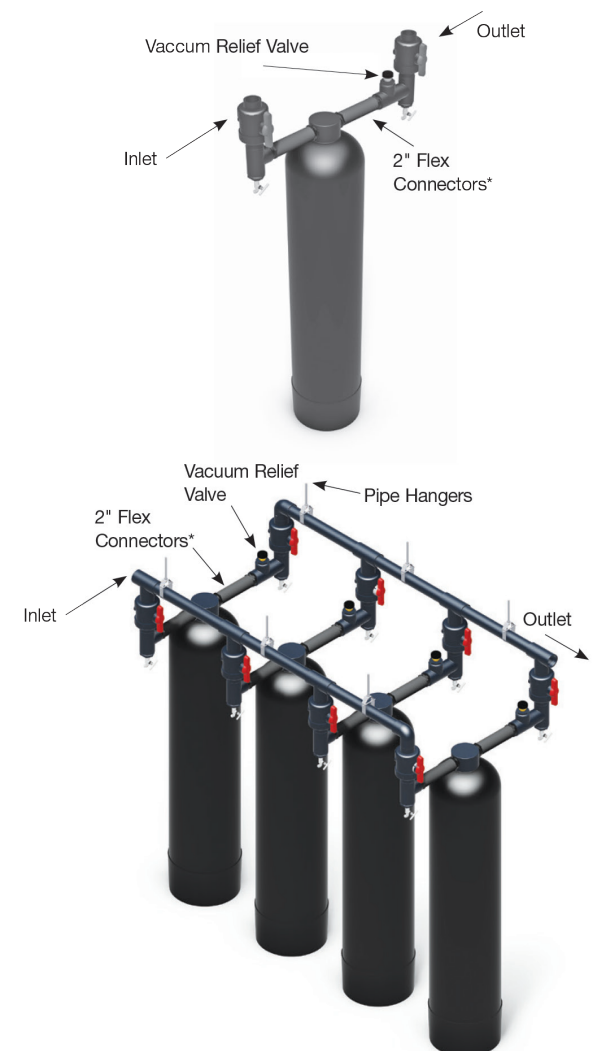

NOTICE

Your AquaSolve media should be replaced every 3 years. Dispose of old media and/or container in accordance with local, regional, national, and/or international regulations.

Replacing the Media

1. Shut off the primary water supply going to the AquaSolve tank.
2. Open up a downstream spigot or faucet to release pressure in the tank and in the distribution lines before and after the system.
3. Close the inlet and outlet isolation valves immediately before and after the tank and open the bypass valve.
4. Disconnect the unions on the inlet and outlet of the tank, and then disconnect flex connectors from head.
5. Using a step ladder and strap wrench, remove the threaded head assembly connection (turning counter-clockwise) and remove the complete upper assembly including the screen attached to the bottom of the head assembly. Rinse these parts in a nearby sink or bucket of water. Do not drain the tank.
6. Remove the distributor tube with the bottom strainer. Rinse these parts in a nearby sink or bucket of water.
7. Get a 6ft length of 3/4" sch. 40 PVC and a length of 1" polyvinyl hose. The length of hose depends on the distance to the nearest floor drain. (Both of these can be acquired at a local hardware store.)
8. Insert one end of the pipe inside the hose and put the other end of the pipe into the top of the tank and down into the media. Put the other end of the hose inside a rice bag and put the rice bag on the floor drain.
9. Get a garden hose and put it on the open end of the poly hose to fill the hose and pipe with water. Air will bubble out of the tank. Once all the air is out of the hose and pipe, you can start a siphon to remove the media. Put the garden hose in the top of the tank and turn it on to keep the tank full of water. Push the pipe up and down in the media to get it all out. The rice bag will catch the media and allow the water to go down the drain.
10. Try not to be too aggressive when extracting the media. You need to take it out in small bites. If you let the whole pipe/ hose fill with media it will plug up. You need to let slugs of water flush out the pipe as you go.
11. When all the old media is removed turn off the garden hose and continue to siphon until the tank is about half full with water.
12. Using the step ladder again, reinstall the distributor tube with bottom strainer that was removed in step #6. Center the distributor tube in the bottom of the tank. Make sure the distributor tube is flush with the top of the tank and cap the top open end of the distributor tube and plastic sheeting. Keeping any and all media from entering the distributor tube, carefully pour-in a new bag(s) of media that specifically meets the replacement requirement of the tank. For example, an AM8416TM-COM system requires (x1) AM8416-COM-RM Replacement Media.
13. Inspect the threaded connection on the top of the tank to ensure no loose beads of media are stuck to the internal threads. If visible, wipe away the beads with a damp cloth, then remove the plastic sheeting and tape from the top of the distributor tube.
14. Re-attach the head assembly onto the distributor tube and thread the head assembly back onto the tank. Hand-tighten until the final turn when a strap wrench can help tighten the connection.
15. Reconnect the flex connectors and union connections.
16. Fully open the primary water supply valve and close the bypass valve.
17. Slowly open the outlet isolation valve and slightly open the inlet isolation valve to allow water to flow into the system and out of a downstream cold side faucet to purge the air from the tank and plumbing system.
18. Once the tank is full of water, wait 4 hours for media to "hydrate".
19. Slowly, fully open the inlet isolation valve. The system is now ready for operation.

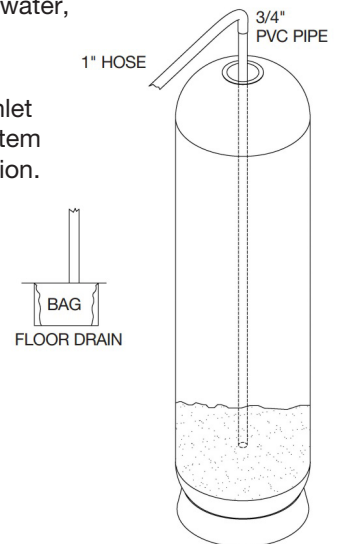

Alternative Method for Replacing Media

Follow steps 1 – 6 then,

- Remove center distributor tube and lower basket and siphon all water from tank
- Lay tank down on its side and tip upside down while using hose to flush media out
- When all the old media is removed, stand tank back up and install in original position. Fill the tank so that it is about half full with water.

Then continue with steps 12 – 19.

Parts List			
Item	Qty.	Part #	Description
1a	1	144064	SS tank head only
1b	1	149692	Upper basket assembly
2	2	144065	Flex hose 2" x 12"
3	1	144066	Distributor tube and bottom distributor assembly
4a	1	148763	14" X 65" tank 4" top
4b	1	148784	16" X 65" tank 4" top

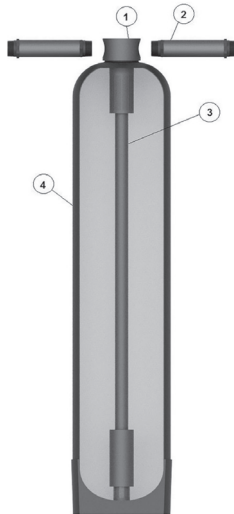

Limited Warranty

AERCO warrants its AquaSolve tank system as follows:

- AquaSolve tank system is warranted to be free of defects in materials and workmanship for 5 years from the date of original shipment.
- The AquaSolve media is warranted for performance for a period of 2 years from the date of the original installation when installed and operated in accordance with the instructions in the corresponding Installation and Operation Manual.

Conditions

1. AquaSolve system must be installed in applications with municipally supplied water adhering to EPA guidelines with the exception of oil and grease, copper, phosphate, silica and chlorine. See copper warnings on page 2 and condition number 5 below.
2. Any component failure must not result from abuse, fire, freezing or other acts of nature, violence, or improper installation.
3. Equipment must be installed and operated in compliance with the local plumbing codes and on an approved water supply.
4. Equipment is limited to use at water pressures and temperatures that do not exceed our published specifications.
5. Water supply must not exceed 2.0 PPM chlorine. For water supply exceeding 2.0 PPM chlorine, pretreatment is required. (Please contact your water treatment specialist.)
6. Information, including model number, serial number, and date of installation, must be provided for any claims pertaining to equipment in warranty.
7. Defective parts are subject to inspection by either AERCO or any authorized representative before final commitment of warranty adjustment is made.
8. AERCO reserves the right to make changes or substitutions in parts or equipment with material of equal quality or value and of then current production.

Limitations

Our obligation under this warranty with respect to the tank or valve is limited to furnishing a replacement for, or at our option, repairing any part or parts to our satisfaction that prove defective within the warranty period stated above. Such replacement parts will be delivered to the owner F.O.B. nearest factory, at no cost, excluding freight and local labor charges, if any. Our obligation under this warranty with respect to the AquaSolve media will be limited to furnishing a replacement for the media within two years from date of original installation. Such replacement media will be delivered to the owner F.O.B. nearest factory, at no cost, excluding freight and local labor charges, if any. Damage to the media due to chlorine, other oxidizers or fouling caused by local water conditions or any other operation outside of the limits shown under Specifications, is not covered by this warranty.

The warranty set forth herein is given expressly and is the only warranty given by AERCO company with respect to the product. AERCO company makes no other warranties, express or implied. AERCO company hereby specifically disclaims all other warranties, express or implied, including but not limited to the implied warranties of merchantability and fitness for a particular purpose.

The remedy described under this warranty shall constitute the sole and exclusive remedy for breach of warranty, and AERCO company shall not be responsible for any incidental, special or consequential damages, including without limitation, freight, handling, lost profits or the cost of repairing or replacing other property which is damaged if this product does not work properly, other costs resulting from labor charges, delays, vandalism, negligence, fouling caused by foreign material, damage from adverse water conditions, chemical, or any other circumstances over which AERCO company has no control. This warranty shall be invalidated by any abuse, misuse, misapplication or improper installation of the product.

Some states do not allow limitations on how long an implied warranty lasts, and some states do not allow the exclusion or limitation of incidental or consequential damages. Therefore the above limitations may not apply to you. This warranty gives you specific legal rights, and you may have other rights that vary from state to state. You should consult applicable state laws to determine your rights. So far as is consistent with applicable state law, any implied warranties that may not be disclaimed, including the implied warranty of merchantability and fitness for a particular purpose, are limited in duration to the applicable warranty periods stated above.