

Technical Data Sheet

MFC 3000-10000 Boilers

The AERCO Multi-Fuel Condensing (MFC) Fire Tube Water Boiler is designed for condensing application in any closed loop hydronic system. It features a proven 4-pass fire tube heat exchanger design for maximum heat transfer and efficiency. The heat exchanger's combination of high quality carbon steel/316Ti stainless steel construction ensures the highest degree of durability.

The 316Ti SS construction in the heat exchanger's 4th pass offers superior corrosion resistance against acidic flue gas condensation. Likewise, it can be fired with multiple fuels including natural gas, propane or #2 fuel oil (as backup), offering dual fuel flexibility. Moreover, the MFC series features dual return connections standard for optimal application flexibility and seasonal efficiency gains of up to 10%. The heat exchanger's maximum working temperature of 240°F allows for greater operating temperature range and meet the requirements of higher temperature applications when necessary, but allows for the building to reset water temperature for condensing in the shoulder months.

The MFC Series is fitted with industry leading power burners whose emissions will meet most stringent NOx and CO requirements. The fully modulating burner also maintains AERCO standards for energy efficiency, longevity, reliability and construction quality.

The MFC Series boilers can be used as an individual unit or in modular arrangements and offers selectable modes of operation. In addition to controlling the boiler according to a constant set point, indoor/outdoor reset schedule or 0-10V signal, one or more units can be integrated via Modbus communications protocol. For boiler plants ranging from 2 or more boilers, the AERCO 64128 controller designed to optimize plant efficiency provides the right solution. Likewise, MFC systems can be easily integrated with a facility-wide Energy Management or Building Automation System.



Features

- Natural gas, propane, or dual fuel (#2 fuel oil backup)
- Full condensing on natural gas/propane
- Condensing capability on #2 fuel oil (<15 ppm sulfur content)
- Up to 5:1 turndown ratio (20%) when firing on natural gas or propane
- High quality combined carbon steel/316Ti SS 4-pass fire tube heat exchanger
- Capable of variable primary flow installations
- Dual return water connections
- NOx emissions capable of 40 PPM or less @ all firing rates when firing on natural gas (depending on model)
- Precise temperature control
- Standard industry leading power burner (Riello)
- Ducted combustion air capable
- Easy serviceability
- Acceptable vent materials AL29-4C
- Controls options: constant setpoint, indoor/outdoor reset, remote setpoint, 0-10V signal or ModBus

Ratings

Model	Min Input MBH ^a	Max Input MBH	Max Output MBH ^b	Efficiency Range	Preliminary AHRI Efficiency 80° to 180°F
MFC 3000	600	3000	2580-2790	85.5%-94.2%	92%
MFC 4000	800	4000	3440-3720	85.5%-94.2%	92%
MFC 5000	1000	5000	4300-4650	85.5%-94.2%	92%
MFC 6000	1200	6000	5160-5580	85.5%-94.2%	92%
MFC 8000	1600	8000	6880-7440	85.5%-94.2%	92%
MFC 10000	2000	10000	8600-9300	85.5%-94.2%	92%

^a Values based on natural gas/propane firing

^b Max output dependent upon application - See efficiency curves

Dimensions

Model	A (Width)	B (Length)	C (Height)	D	E	F	G	H	I	J	K	L	M	N	O	P	Q	R	S (REF)	T
MFC 3000	54.3"	171.5"	84.0"	63.0"	128.3"	6.6"	72.9"	0.6"	12.6"	35.2"	73.0"	48.9"	7.1"	2.6"	18.1"	6.5"	27.6"	6.9"	27.2"	2.1"
MFC 4000	58.7"	174.1"	88.3"	66.1"	130.9"	7.3"	75.4"	4.5"	16.2"	36.2"	76.2"	48.9"	5.5"	2.6"	17.3"	6.5"	27.6"	6.9"	29.3"	2.1"
MFC 5000	58.7"	186.3"	88.3"	66.1"	143.1"	7.3"	75.4"	4.5"	16.2"	36.2"	76.2"	49.3"	5.5"	2.6"	17.3"	6.5"	35.6"	6.9"	29.3"	2.1"
MFC 6000	70.9"	188.9"***	101.1"	76.8"	145.7"	8.5"	87.1"	3.1"	22.8"	40.9"	86.8"	50.3"	6.5"	**	21.1"	6.5"	53.2"	6.7"	35.4"	2.1"
MFC 8000	70.9"	220.4"	102.3"	76.8"	165.4"	8.5"	87.1"	7.8"	22.8"	40.9"	86.8"	53.8"	5.0"	3.1"	18.1"	7.2"	55.9"	7.1"	35.4"	2.1"
MFC 10000	70.9"	240.0"	102.3"	76.8"	185.0"	8.5"	87.1"	7.8"	22.8"	40.9"	86.8"	52.7"	5.0"	3.1"	18.0"	7.2"	70.9"	7.9"	35.4"	2.1"

*Dimensions and information for #2 fuel oil connections can be found in MFC Series O&M Manual GF-148.

**MFC 6000 includes an 8"x6" reducer. The reducer goes past the frame 4".

MFC 3000-10000

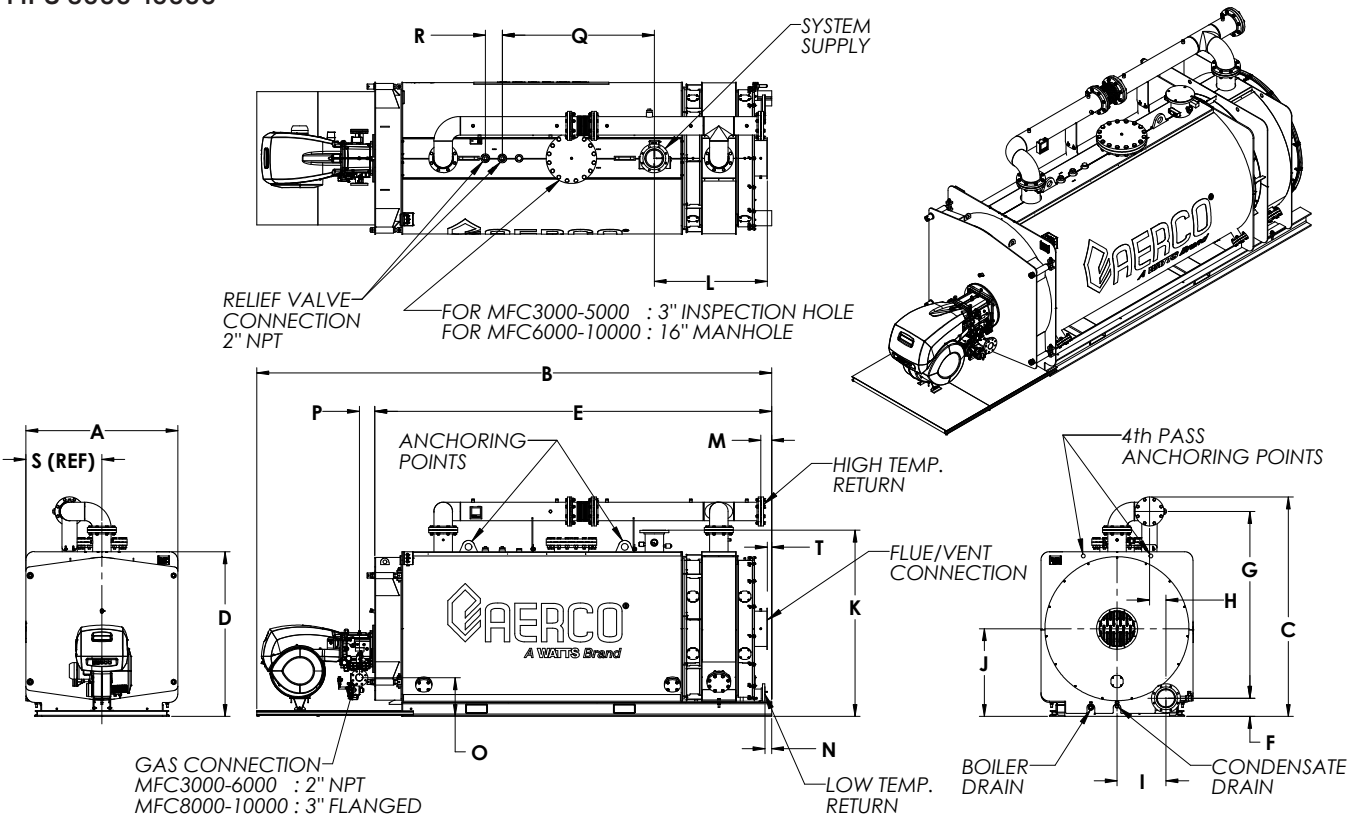

Specifications

	MFC 3000	MFC 4000	MFC 5000	MFC 6000	MFC 8000	MFC 10000
Boiler Category	ASME Sect.IV					
Max. Allowed Working Pressure	80 PSIG					
Max. Working Temperature	240°F					
Gas Connections (NPT)	2"	2"	2"	2"	3" (Flange)	3" (Flange)
Oil Connections	.375"	.375"	.5"	.5"	.5"	.5"
Max. Gas Pressure	1 psi	1 psi	1 psi	2 psi	2 psi	2 psi
Min. Gas Pressure ¹	14"	14"	14"	1 psi	1 psi	1 psi
Max #2 Fuel Oil Consumption Flow rate (GPH)	21.4	28.6	35.7	42.9	57.1	71.4
#2 Fuel Oil Supply Flow Rate (GPH)	85	150	150	150	218	218
Electrical Req. 208V/3PH/60Hz ^{2,3}	11.4 FLA	16.8 FLA	16.8 FLA	16.8 FLA	25.8 FLA	25.8 FLA
Electrical Req. 460V/3PH/60Hz ^{2,3}	5.8 FLA	7.6 FLA	7.6 FLA	7.6 FLA	11.7 FLA	11.7 FLA
Electrical Req. 575V/3PH/60Hz ^{2,3}	4.5 FLA	6.2 FLA	6.2 FLA	6.2 FLA	10.2 FLA	10.2 FLA
Water Connections (Flanged)	4"	6"	6"	6"	8"	8"
Dual Return Water Connections	√	√	√	√	√	√
Min. Water Flow (GPM)	0	0	0	0	0	0
Max. Water Flow (GPM)	350	520	610	750	1000	1100
Water Volume Gallons	407	464	518	724	898	1043
Water Pressure Drop	2.4 PSIG @300GPM	1 PSIG @400GPM	1.3 PSIG @500GPM	1.9 PSIG @600GPM	1.1 PSIG @800GPM	1.7 PSIG @1000GPM
Turndown (Nat.Gas/Propane)	Up to 5:1 (20%)					
Turndown (#2 Fuel Oil)	Up to 3:1 (33%)					
Vent/Air Intake Connections ⁴	10 Inch	12 Inch	12 Inch	14 Inch	16 Inch	16 Inch
Vent Materials	AL29-4C					
Type of Fuel	Natural Gas, Propane, #2 Fuel Oil [backup]	Natural Gas, Propane, #2 Fuel Oil [backup]	Natural Gas, Propane, #2 Fuel Oil [backup]	Natural Gas, Propane, #2 Fuel Oil [backup]	Natural Gas, Propane, #2 Fuel Oil [backup]	Natural Gas, Propane, #2 Fuel Oil [backup]
NOx Emissions on Nat. Gas	30 ppm	30 ppm	30 ppm	30 ppm	40 ppm	40 ppm
Temperature Control Range	125°F to 230°F					
Minimum Water Inlet Temperature	100°F					
Ambient Temperature Range	32°F to 140°F					
Standard Listings & Approvals	UL, CUL, CSD-1, ASME, AHRI (in process)					
Gas Train Operations	FM Compliant or Double Block and Bleed (IRI)					
Weight (dry) / Shipping Weight lbs.	7,300	10,160	11,063	13,137	16,645	18,520
Weight (wet) lbs.	10,694	14,030	15,383	19,175	24,134	27,219

¹ Values are for Natural Gas FM Compliant 2" gas trains available with Riello Dual Fuel (light oil/gas) burners. Additional gas train sizes with added gas pressure ranges are available. Consult factory or see MFC Series Gas/Oil Components & Supply Design Guide GF-148-G for additional model gas train minimum gas pressure requirements.

² See MFC Electrical Power Guide GF-148-E for Service Disconnect Switch amperage requirements.

³ Values are for Riello Dual Fuel (light oil/gas) RLS 120-300 models. Consult MFC Electrical Power Guide GF-148-E for additional model and power requirements.

⁴ Ducted combustion air connections available on MFC 3000-6000 models.



Notes



Heat | Hot Water | Energy Recovery Solutions

AERCO International, Inc. • 100 Oritani Drive • Blauvelt, NY 10913
USA: T: (845) 580-8000 • Toll Free: (800) 526-0288 • AERCO.com