



# ITT



**Hoffman Specialty**  
Installation & Maintenance  
Instructions  
HS-222(E)

## Float and Thermostatic Traps Series H, C and X

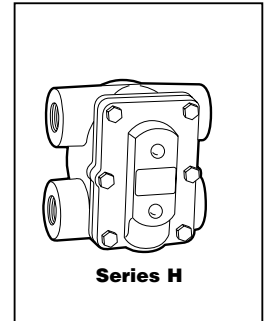
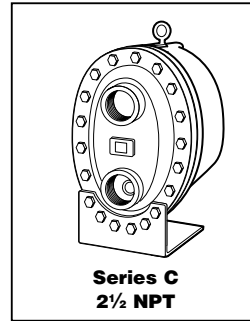
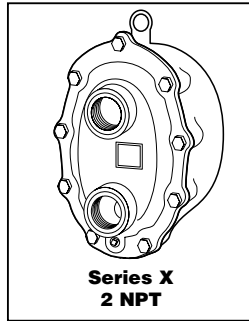
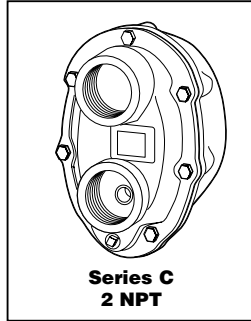
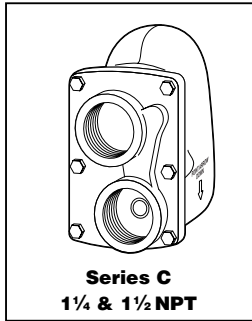

Ratings		
NPT Size - in.	Maximum Temperature °F (°C)	Max. Operating Pressure psig (bar)
3/4", 1" and 1 1/4" H	406 (208)	175 (12.1)
1 1/4" C and All 1 1/2" - 2 1/2"	377 (192)	



### WARNING

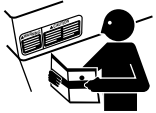

- Before using product, read and understand instructions.
- Save these instructions for future reference.



- All work must be performed by qualified personnel trained in the proper application, installation, and maintenance of steam systems in accordance with all applicable codes and ordinances.
- To prevent serious burns, wear heat resistant gloves when opening and closing steam valves, or handling hot equipment.



- To prevent serious burns, the internal pressure of the trap must be 0 psi (0 bar) before servicing.
- To prevent serious personal injury from steam pipe blow down, connect a temporary pipe between the steam pipe opening and a drain, or stand at least 100 ft. (30 m) from the front of the pipe opening.



- To prevent property damage, personal injury, or death, cap off the gate valves if they are not connected to a drain and when they are not in use for test or pressure relief.

Failure to follow this warning could cause property damage, personal injury or death.

*Engineered for life*



# OPERATION

Float and thermostatic traps have two basic elements: a thermostat for venting air from the system during start-up and a float assembly for draining condensate.

The thermostat is normally open. It allows air to vent until it is within 10-30°F (4-12°C) of the steam temperature.

The float assembly drains condensate from the system when buoyancy force lifts the float ball and opens the valve. The weight of the float ball causes the pin to close against the trap seat when condensate is not present.

Materials of Construction	
Part	Specifications
Body and Cover	Cast Iron 30,000 psi tensile
Valve Pin and Seat	Stainless Steel (Hardened)
Float	Stainless Steel
Lever Assembly	Stainless Steel
Thermostatic Air Vent	Stainless Steel Cage and Thermal Element
Cover Bolts	Grade 5
Baffle	Stainless Steel {2 1/2" units only}

	<p><b>WARNING</b></p> <p>To prevent serious personal injury from steam pipe blow down, connect a temporary pipe between the steam pipe opening and a drain, or stand at least 100 ft. (30m) from the pipe opening.</p>
	<p>Failure to follow this warning could cause property damage, personal injury, or death.</p>

# INSTALLATION – Series H, C and X Float and Thermostatic Steam Traps

## STEP 1

- Determine where to install the trap, based on the following requirements:
  - The trap must be located as close as possible to, and below the equipment to be drained.
  - The trap must be in a straight run of horizontal pipe as shown in the “Typical Piping Diagrams,” and pitched to allow condensate to flow into trap inlet, and away from trap outlet.
  - Allow for enough space around the trap for servicing, which may include removal of the body or cover, depending on the model you are installing.

The Hoffman Series H traps provide an additional opening where a test valve may be installed. On traps that do not have an additional opening, the test valve can be installed in a tee fitting in the discharge line.

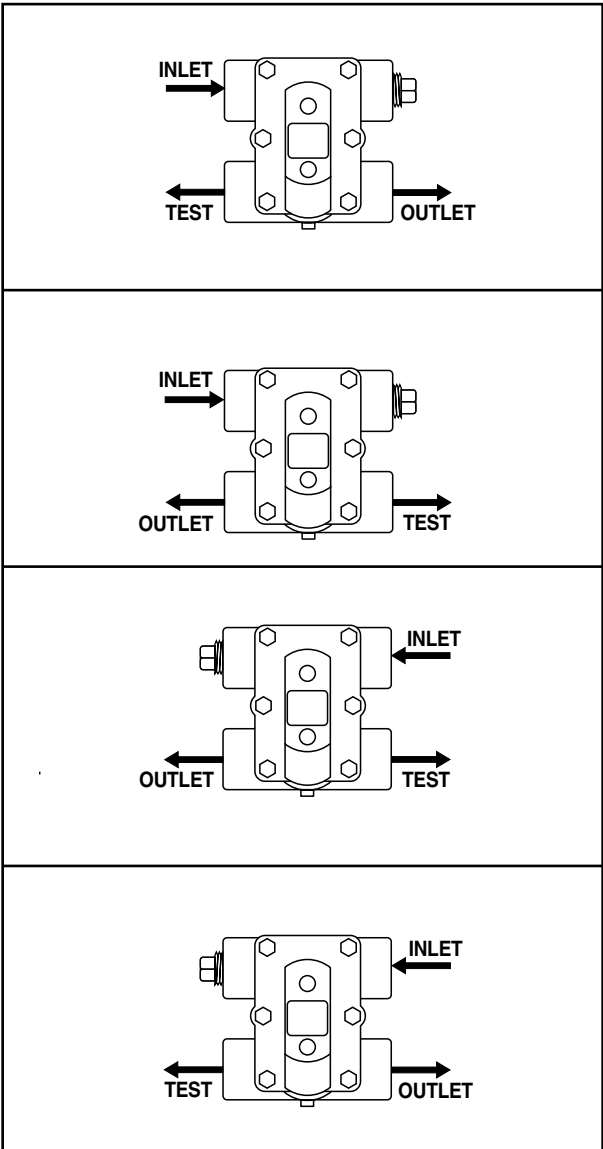

## STEP 2

**IMPORTANT:** To prevent system damage from water hammer or sudden shock, open supply valves slowly.

If you are uncertain about the product's adaptability for your application, please call the factory or authorized representative before using the product.

The trap seat rating (stamped on the nameplate) must be equal to or greater than the maximum pressure differential across the trap.

- Install a Hoffman Specialty Y-strainer in the pipe, ahead of the steam trap. This prevents dirt from entering the trap.
- Install a blow down valve by connecting it to the strainer drain plug. This allows the Y-strainer to be cleaned.
- Install a shut-off valve in the inlet pipe and the outlet pipe. This allows the trap to be isolated when servicing.
- Install a test valve in the outlet pipe, and cap it. This allows the trap to be tested. The cap is used as safety precaution when the unit is not being tested.
- Blow down the piping using full steam pressure for (5) five minutes. This cleaning process will remove debris from the pipe and oil from the system.

Test traps by following the "Troubleshooting" procedure on page 6.

### TYPICAL PIPING DIAGRAMS

#### Series H Trap Draining to Gravity Return Line

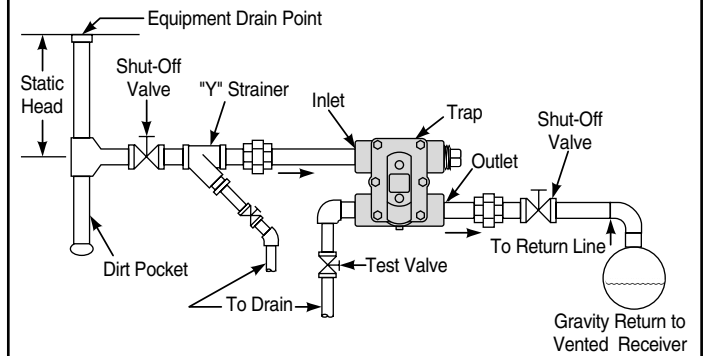

#### Series C and X Pattern Trap Installations

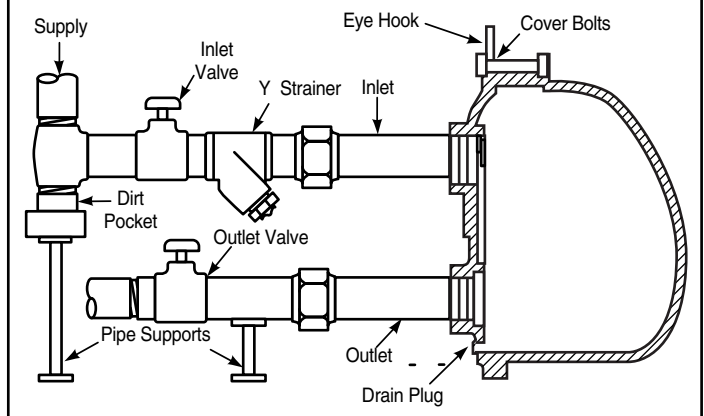

#### 2½" Series C Pattern Trap Installations

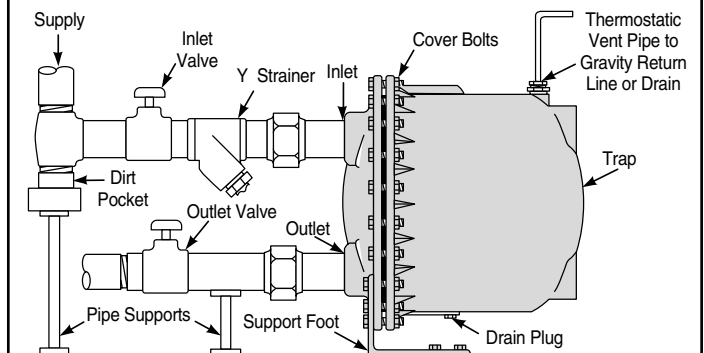

	<p><b>WARNING</b></p>
	<p>To prevent serious personal injury from steam pipe blow down, connect a temporary pipe between the steam pipe opening and a drain, or stand at least 100 ft. (30m) from the pipe opening.</p> <p>Failure to follow this warning could cause property damage, personal injury, or death.</p>

## REPAIR PROCEDURES FOR ALL TRAPS

### REMOVAL FROM SERVICE

1. Close inlet and outlet supply valves and allow unit to cool. If a test valve is installed, open this valve to relieve any pressure.
2. Remove the drain plug to drain condensate from the trap body.
3. Remove the bolts that attach the cover to the body.

## SERIES H TRAPS



### REPAIR

4. With cover assembly removed from trap body, remove pin that holds lever assembly to yoke. Inspect seat and pin for wear, replace if worn.
5. Inspect thermostatic element by placing it in boiling water to see if it closes. If it doesn't close, replace it.
6. Check alignment of pin and seat, adjust or replace parts as necessary.
7. Check float ball for damage, shake the float to make sure there is no fluid inside the float. Replace if necessary.
8. Clean gasket surfaces and install new cover gasket.
9. Reassemble the cover to the body. Tighten the bolts in the indicated sequence shown on page 5. Torque all bolts evenly to the indicated values.

## SERIES C & X TRAPS

### REPAIR

4. With body assembly removed from trap cover, remove pin that holds lever assembly to yoke. Inspect seat and pin for wear, replace if worn.
5. Inspect thermostatic element by placing it in boiling water to see if it closes. If it doesn't close, replace it.
6. Check alignment of pin and seat, adjust or replace parts as necessary.
7. Check float ball for damage, shake the float to make sure there is no fluid inside the float. Replace if necessary.
8. Clean gasket surfaces and install new cover gasket.
9. Reassemble the body to the cover. Tighten the bolts in the indicated sequence shown on page 5. Torque all bolts evenly to the indicated values.

 <b>CAUTION</b>	
	<b>To prevent serious burns, the internal pressure of the trap must be 0 psi (0 bar) before servicing.</b>
	<b>Failure to follow this caution will cause personal injury.</b>

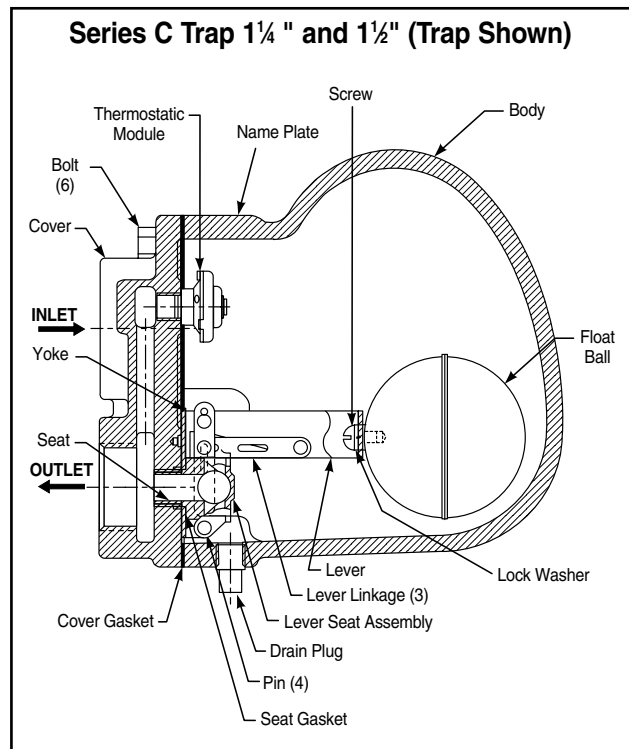
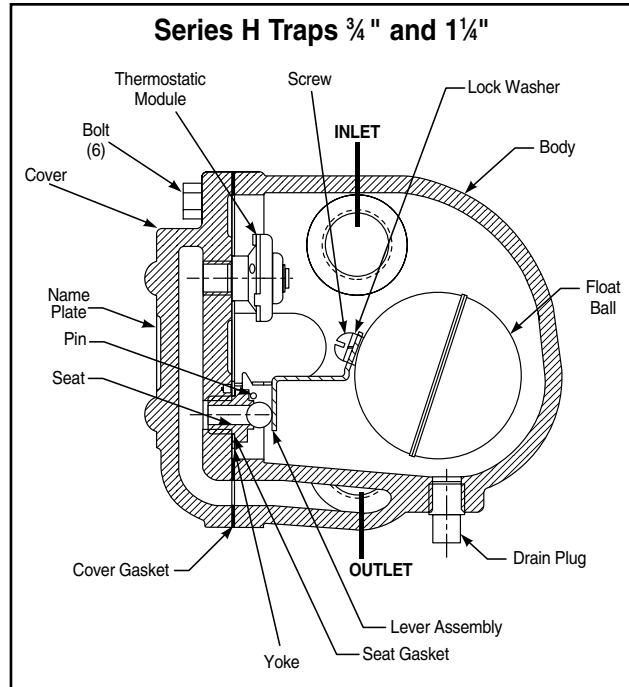

## Internal Component Detail Illustration

### Series C Trap Cover 2" Standard Capacity

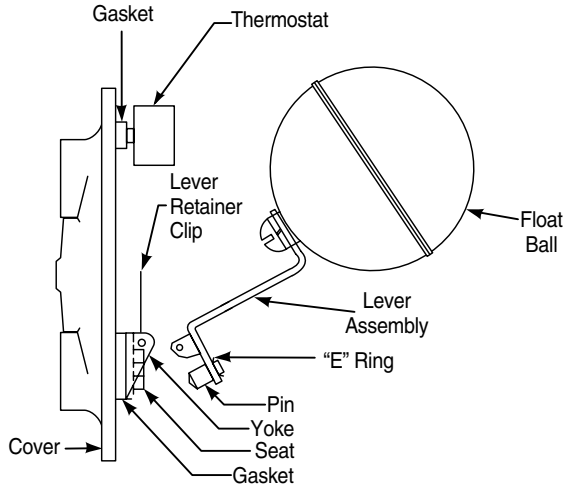

### Series X Trap Seat and Yoke 2"

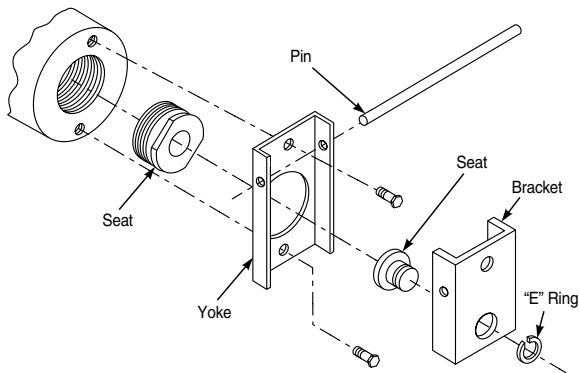

### Series C Seat and Yoke 2 1/2" Units

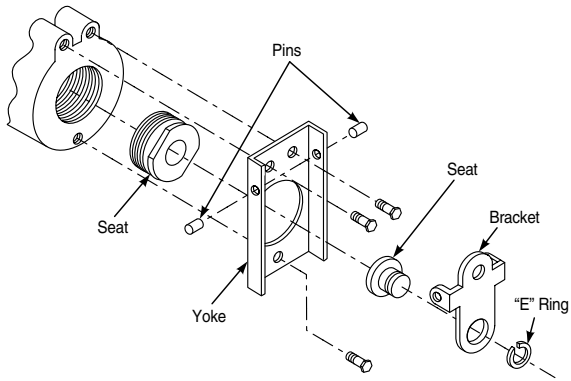

## RETURN TO SERVICE

10. Insert and securely tighten drain plug.
  11. Open supply valve on trap outlet side, slowly open the supply valve to the trap inlet.
  12. Check for leaks and normal operation.
- Test traps by following the "Troubleshooting" procedure on page 6.

## Cover Bolt Pattern Layout

Tighten and torque bolts in numerical order, beginning with #1.

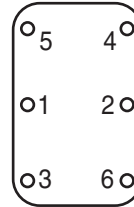

**Series H 3/4" to 2" Traps and Series C 1 1/4" and 1 1/2" Traps with six bolt pattern**  
Tighten Bolts to 28 +/- 3 ft-lbs. (38 +/- 4 N-m) Torque

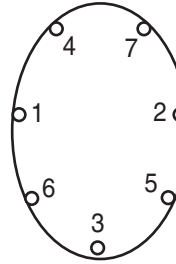

**Series H 1 1/2" and 2" Traps with seven bolt pattern**  
Tighten Bolts to 28 +/- 3 ft-lbs. (38 +/- 4 N-m) Torque

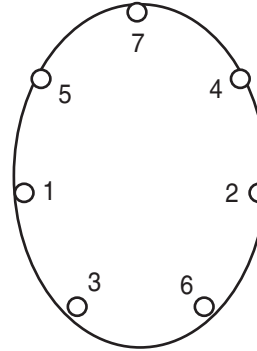

**Series C 2" Traps**  
Tighten Bolts to 75 ft-lbs. (102 N-m) Torque

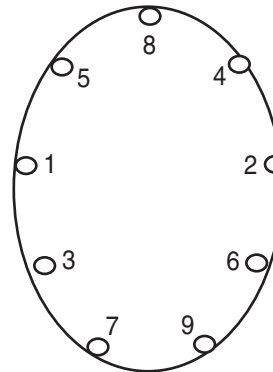

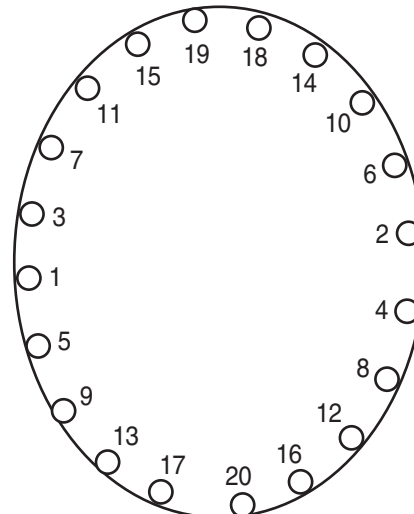

**Series X 2" Traps**  
Tighten Bolts to 150 ft-lbs. (205 N-m) Torque



**Series C 2 1/2" Traps**  
Tighten Bolts to 75 ft-lbs. (102 N-m) Torque



## MAINTENANCE

	<p><b>WARNING</b></p>
	<p>To prevent serious personal injury from steam pipe blow down, connect a temporary pipe between the steam pipe opening and a drain, or stand at least 100 ft. (30m) from the pipe opening.</p> <p>Failure to follow this warning could cause property damage, personal injury, or death.</p>

When checked regularly and properly maintained, the Series FT Float and Thermostatic traps will provide optimum performance and long life.

### SCHEDULE:

- Initially, every 2 - 3 days after start-up until system is clean.
- Every 6 months thereafter.

	<p><b>CAUTION</b></p>
	<p>To prevent serious burns, the internal pressure of the trap must be 0 psi (0 bar) before servicing.</p> <p>Failure to follow this caution will cause personal injury.</p>

1. Inspect joints for leaks. Stop all leaks by tightening bolts and replacing gaskets, if necessary.
2. Clean strainers by opening the blow down valve and allowing full steam pressure to flow out for (2) two minutes. Then, close the valve.

## TROUBLESHOOTING

Problem:

### 1. Improper heating.

- a. **Cause:** Thermostat failed closed and prevents air from escaping.  
**Test:** Blow air through the thermostat when it is at normal room temperature, for a visual check. If air does not pass through, the thermostat is not functioning properly.
- b. **Cause:** Float assembly failed closed and caused condensate to back-up into the steam space.  
**Test:** Using a stethoscope, listen for a gurgling sound. No gurgling indicates that condensate is not draining.

### OR

Using a thermometer, check the trap discharge temperature. If the temperature is lower than normal, the condensate is not draining.

- c. **Cause:** Incorrect trap seat pressure selected.  
**Test:** Check seat pressure rating on trap nameplate. The seat pressure rating must be equal or higher than the steam supply pressure.

### 2. Energy wasted.

- a. **Cause:** Thermostat failed open and allowed live steam to blow through the trap.  
**Test:** Using a stethoscope, listen for a low pitch whistle as steam passes through the open orifice. A whistle indicates the thermostat failed open.
- b. **Cause:** Float assembly failed open and allowed live steam to blow through the trap.  
**Test:** Install a test valve in the discharge line from the trap outlet. Observe the trap operation for steam leakage. Excessive steam leakage indicates the float assembly failed open.

### OR

Using a stethoscope, listen for a low pitch whistle by positioning the stethoscope near the thermostat or the float assembly. A whistle indicates the thermostat or float assembly (depending on where the stethoscope is positioned) failed open.