

**STANDARD CONSTRUCTION:**

MATERIAL - CARBON STEEL  
 SHELL THICKNESS - 1/4" 516 GRADE 70  
 HEAD THICKNESS - 1/4" 414G  
 INTERIOR LINING - PORCELAIN ENAMEL  
 EXTERIOR - INSULATED, STEEL JACKET  
 SACRIFICIAL ANODES - MAGNESIUM  
 M.A.W.P. - 125 PSIG  
 MAX. OPERATING TEMP. - 180 F  
 APPROX. WEIGHT EMPTY - 1,965 LBS  
 APPROX. WEIGHT FLOODED - 9,101 LBS

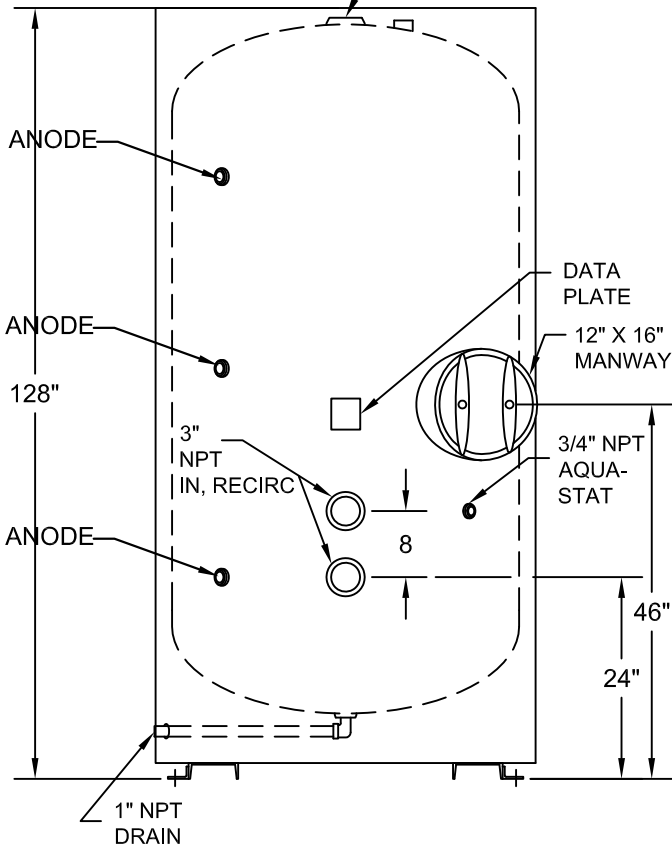
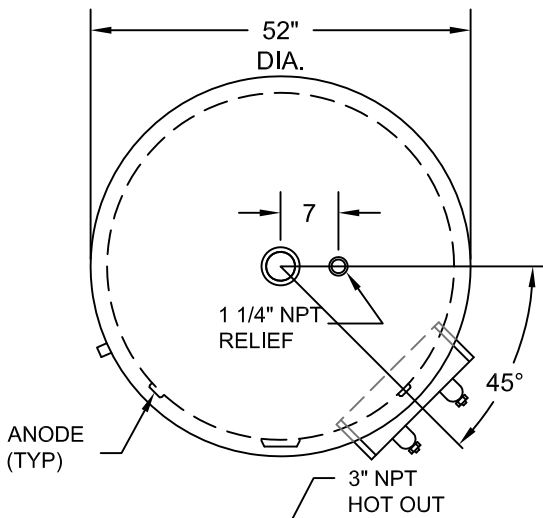

**OPTIONS:**

CHECK ALL THAT APPLY



CONSTRUCTION
DOUBLE GLASS LINING (10-YR WARRANTY)
150 PSI WORKING PRESSURE:

**OPTIONAL PRESSURE ONLY RELIEF VALVE  
 (SHIPPED LOOSE):**

CHECK ONE

125 PSI (USE FOR  
 STANDARD CONSTRUCTION)

150 PSI (USE FOR  
 150 PSI CONSTRUCTION)

3096 MBH

3655 MBH

5011 MBH

5916 MBH

8668 MBH

10234 MBH

**AERCO INTERNATIONAL, INC.**  
 BLAUVELT, NY 10913

**POTABLE WATER STORAGE TANK  
 48" DIA., 860 GALLON, JACKETED  
 ASME IV-HLW**

DWN. BY CZ DATE 091014  
 SCALE NTS SIZE \_\_\_\_\_  
 CHKD. \_\_\_\_\_ APPD. \_\_\_\_\_  
 REV. DATE \_\_\_\_\_

**AP-A-999**

REV.

**A**